

Board of Education Regular Meeting

Monday, August 18, 2025 8:00 PM

Conference Room #101, 609 Whitney St, Pender, NE 68047-0629

1. **The mission of the Pender Public School District is to provide quality educational opportunities in a safe, positive learning environment that motivates and challenges all students to become productive and responsible citizens.**

2. **Call to Order, Roll Call, Establishment of a Quorum**

3. **Approve Minutes of Previous Meetings**

4. **Financial Report**

5. **Approve Payment of Bills**

6. **Administrative Reports**

7. **Audience with Board**

8. **Teach Town Curriculum**

9. **Minibus Purchase**

10. **Purchase of Risers**

11. **Utility Vehicle**

12. **Pulse - SEL Screener**

13. **Personnel**

1. Resignation (Chris Meyer)

2. Certified Substitutes - Jacque Breitbarth and Tiffany Cumming

14. **Policy**

1. Second Reading (1210, 5008, 5204, 5205, 5207)

2. BOE Policy 5006 and Administrative Regulation (AR) 5006.1 - Enrollment Option - Annual Review

3. BOE Policy 5415 - Bullying - Annual Review

4. BOE Policy 5416 and Administrative Regulation 5416.1 - Student Fees - Annual Review and Hearing

5. BOE Policy 5417 - Wellness Policy - Annual Review

6. BOE Policy 6400 - Parental Involvement - Annual Review and Hearing

7. BOE Policy 6800 - Internet Safety - Annual Review

15. **Pendragon Sports Complex**

1. Concrete, Main Gate to Timberlyne Building & Parking to Timberlyne Building
2. Donor Recognition

3. Seal the exterior of the Timberlyne Building

16. **Executive Session**

17. **Reconvene in Open Session**

18. **Upcoming Meetings/Board Opportunities**

1. Special Board Meeting - August 26, 7:15 am, Room 101
2. NASB Area Membership Meeting - August 27 - Norfolk
3. Next Regular Meeting - September 8, 2025

19. **Adjournment**

20. **The sequence of agenda topics is subject to change at the discretion of the board. Please arrive at the beginning of the meeting.**

PENDER PUBLIC SCHOOLS BOARD OF EDUCATION MEETING MINUTES
Pender Public Schools – Conference Room
July 16, 2025 – 7:00 p.m.

The Pender Public School Board of Education met in regular session in the Conference Room on Wednesday, July 16, 2025. President Matt Peters called the meeting to order at 7:13 p.m. with the following members present: Matt Heineman, Jean Karlen, Mandy Johnson, Jason Roth, JJ Maise and Matt Peters. Also present were Superintendent Jason Dolliver, Elementary Principal/SPED Director Kelly Ballinger and Recording Secretary Deanna Hansen

As required by Nebraska Statute 84-1412(8), President Peters drew the attention of those present to the location of information regarding the Open Meetings Act posted in the meeting room and accessible to all members of the public.

President Peters reviewed the agenda as presented, affirmed that every board member had received notice of the meeting, and confirmed that the time and place of the meeting had been published or posted as required by Board Policy 8342.

A motion to approve the minutes of the June 9, 2025, regular board meeting as presented was made by Maise and seconded by Heineman. President Peters stated the motion and the result of roll call vote being all ayes (5-0, Johnson abstain) motion carried.

Superintendent Dolliver presented the Financial Reports, reviewing the expenses and revenue for the General, School Nutrition and Activity Funds.

The bills were reviewed. Board members asked questions about several invoices and answers were provided.

A motion to approve financial reports and payment of bills as follows: General Fund - \$319,536.93; School Nutrition Fund - \$36,236.13; Activity Fund - \$29,643.31; Employee Benefit Fund - \$3,599.94; Special Building Fund - \$167,965.04 and Payroll - \$209,597.43 was made by Johnson and seconded by Roth. President Peters stated the motion and the result of roll call vote being all ayes (6-0) motion carried.

Superintendent Jason Dolliver and Elementary Principal/SPED Director Kelly Ballinger presented administrative reports. Mrs. Ballinger also presented Secondary Principal Luke Hoffman's report with the Board. These reports can be seen in their entirety by logging on to the Pender School website (<https://penderschools.org>), clicking on the Board of Education tab, selecting eMeeting and opening the attached reports. A printed copy can be obtained at the school. Some of the topics covered in the reports include:

<u>Superintendent</u>	<u>Secondary Principal</u>	<u>Elementary Principal</u>
Mission Statement	Workshops/Meetings	Mission Statement
Professional Goals	LB 399	Professional Goals
Workshops/Meetings	Workshops/Meetings	Workshops & Meetings
School Improvement	25-26 Projected Class Sizes	LB 399
Budget Timeline	New Teacher	Summer Services
End of Fiscal Year	Fine Arts	25-26 Class Size Projections
Valuation	HS & JH National Rodeo	SPED Caseload Info
Assistant Bowling Coach	PPS Alumni Weekend	Teach Town Curriculum

Softball
Minibus
Summer Projects Update
Pendragon Sports Complex
NSAA Reimbursement
School Financing Review Commission
August Board Meeting

Student Council
Other Activities

Summer To-Do's

Board Member Roth reported that he and Principal Hoffman planned to attend the June 16th P2T meeting but turned around part way to West Point due to severe weather and hail.

President Peters implemented the Procedures for Public Comment, and no one took advantage of the opportunity to address the board.

Superintendent Dolliver reviewed LB 243 with Board members, stating it started prior to the 23-24 budget year, and we are approaching year 3. The law caps the property tax authority for school districts, and he went on to explain that since Pender has less than 475 students, we can increase our property tax authority by 7% based on LB 243. He reviewed the resolution with the Board and answered questions the Board had. Dr. Dolliver recommended the Board approve the resolution as reviewed.

A motion was made by Karlen and seconded by Heineman to approve the resolution to increase the District's overall property tax request authority by an additional seven percent above the base growth percentage, or other maximum amount as permitted by law. President Peters restated the motion and the result of roll call vote being all ayes (6-0); motion carried.

Superintendent Dolliver presented a letter encouraging PPS to consider continuation of membership in NRCSA and NREA for the 2025-2026 school year. Annual fees for membership in NRCSA of \$850 remained unchanged from the 2024-2025 membership cost, as did the fee for NREA at \$75.00. Dr. Dolliver recommended renewal of the district's NRCSA membership. Board members discussed the value of membership in the Nebraska Rural Community Schools Association.

A motion was made by Roth and seconded by Johnson to approve renewing membership in NRCSA at cost of \$850 and NREA at a cost of \$75.00 for the 2025-26 school year. President Peters stated the motion and the result of roll call vote being all ayes (6-0); motion carried.

Letters soliciting a proposal for petroleum products were mailed to all distributors in the district. Two proposals were received, one from Cubby's, Inc. for 15¢ below pump price and one from Z Mart for 20¢ below pump price. Board members reviewed the proposals. Dr. Dolliver recommended accepting the proposal from Z Mart.

A motion was made by Roth and seconded by Johnson to accept the proposal submitted by Z Mart for 20¢ below pump price for the 2025-26 school year. President Peters stated the motion and the result of roll call vote being all ayes (6-0) motion carried.

Letters soliciting a bid for milk was mailed to Hiland Dairy and Kemps LeMars. One proposal was received from Hiland Dairy. Superintendent Dolliver recommended accepting the proposal from Hiland.

A motion was made by Heineman and seconded by Roth to accept the proposal from Hiland Dairy to provide milk to the district for the 2025-26 school year. President Peters stated the motion and the result of roll call vote being all ayes (6-0) motion carried.

Superintendent Dolliver reviewed the proposed 2025-26 food service, substitute teachers and classified staff, activity fees, activity passes, technology fees and high school and junior high contest admission fees for students and patrons with Board members.

The major increase in fees is on the food service side. Dr. Dolliver reported that he reviewed meal prices with the PLE (Paid Lunch Equity) tool provided by the USDA and NDE. The PLE tool suggested a rate increase of 10¢. The Board reviewed the suggested breakfast and lunch prices. It was also discussed that all families are encouraged to complete the application for free and reduced meals.

Currently the district pays \$155 per day for a substitute teacher and \$16.00 per hour for classified staff member substitutes. After surveying area schools, Dr. Dolliver recommended increasing the rate to \$160 per day for substitute teachers and increasing the classified staff member substitute rate to \$16.50 per hour for the 2025-26 school year.

Dr. Dolliver recommended continuing the technology fee for all K-12th grade students. He reported that all students are issued a school-owned device, with kindergarten and 1st grade receiving iPads, and students in 2nd through 12th grade receiving Chromebooks. Superintendent Dolliver recommended no increase in the technology fee for the 2025-26 school year, with the fee remaining \$25.

Dr. Dolliver and the Board discussed the activity fees and activity pass prices. These are fees that help the Activity Fund and offset expenses. After much discussion it was decided to waive student activity participation fees again for the 2025-26 school year and leave the Activity Pass prices the same as they were during the 2024-25 school year.

A motion was made by Johnson and seconded by Karlen to approve fees for the 2025-26 school year as follows:

- Breakfast: \$3.25-Adult; \$2.45-PK-12 students; Seconds: Main-\$1.45; Side-\$1.15; Milk/Juice-\$.55
- Lunch: \$4.75-Adult; \$3.35-7-12 Students; \$3.10-K-6 Students; \$2.85 Preschool; Seconds: Main Entrée-\$1.95; Side Dish-\$1.45; Milk-\$.55
- Milk Break: \$40/\$80-K-3 students (Semester/Year)
\$30/\$60-Preschool M-T-Th-F am
\$25/\$50-Preschool M-T-Th-F pm (Special Milk Program)
- Substitutes: \$160.00-Teacher; \$16.50/hour-Classified staff
- Activity Fees: Waived for the 2025-26 school year
- Technology Fee: \$25.00 per student, grades Kindergarten through 12th grade
- Activity Passes: \$75.00-Adults; \$65.00-Senior Citizens (62+)
- HS Contests: \$5.00-Adults & Students; PPS students Free
- JH Contests: \$3.00-Adults & Students; PPS students Free

President Peters stated the motion and the result of roll call vote being all ayes (6-0) motion carried.

Marilyn Eason recently informed the District that she is not planning to drive the SPED route to West Point during the upcoming school year. Dr. Dolliver reported that Jessica Reppert had submitted an application soon after school was out for any positions we had available. When this job came open, it made sense to talk with her about it. Along with that, there is time between the morning and afternoon

routes to and from West Point; Jessica was asked if she would be willing to work as a custodian during this time frame, and she is. This is a good situation for PPS, we are able to meet our transportation needs as well as the custodial staff shortage. Superintendent Dolliver recommend approving the work agreement with Jessica Reppert as presented.

A motion was made by Heineman and seconded by Johnson to approve the work agreement with Jessica Reppert as reviewed. President Peters restated the motion and the result of roll call vote being all ayes (6-0), motion carried.

Dr. Dolliver reported that he and Principals Hoffman and Ballinger met with the Policy Committee 2-3 times since the last meeting to review Board Policies and Student / Parent Handbooks. In addition, the Policy Committee also reviewed the suggested additions/changes to the Certified Staff, Classified Staff, Extracurricular Activities Parent / Student, and Coach & Sponsor handbooks.

A motion was made by Johnson and seconded by Karlen to approve the Elementary Parent / Student, Secondary Parent / Student, Certified Staff, Classified Staff, Extracurricular Activities Parent / Student and Coach & Sponsor Handbooks for the 2025-26 school year as reviewed. President Peters stated the motion and the result of roll call vote being all ayes (6-0) motion carried.

A motion was made by Johnson and seconded by Karlen to approve second and final reading of Board Policy 1200, 3131, 3132, 3410, 4003, 4009, 5001, 5004, 5101, 5103, 5201, 5301, 5401, 5414, 5507, 6113, 6400 and 6931, and to rescind Policy 6410 . President Peters stated the motion and the result of roll call vote being all ayes (6-0); motion carried.

A motion was made by Johnson and seconded by Karlen to approve first reading of Board Policy 1210, 5008, 5204, 5205 and 5207. President Peters stated the motion and the result of roll call vote being all ayes (6-0); motion carried.

A motion was made by Johnson and seconded by Roth to approve the first and only reading of revisions to Administrative Regulations 1210.1, 3410.1, 4003.1, 4003.2, 4009.1, 5001.2, 5201.1, 5202.1, 5401.1 and 6113.1. President Peters stated the motion and the result of roll call vote being all ayes (6-0); motion carried.

A motion was made by Karlen and seconded by Johnson to approve the name/number changes to Policy 6113 and AR's 5001.2.1, 5001.2.2, 5001.3 and 5001.4. President Peters stated the motion and the result of roll call vote being all ayes (6-0); motion carried.

Superintendent Dolliver reviewed a list of items and asked that they be declared surplus, and disposition be authorized. Board Policy 3090 provides guidelines for declaring items as surplus and disposing of them. Dr. Dolliver recommended approval of the list as presented.

A motion was made by Maise and seconded by Heineman to declare the list of items as surplus and to authorize the Superintendent to dispose of the items as allowed in Board Policy 3090. President Peters stated the motion and the result of roll call vote being all ayes (6-0), motion carried.

The agenda item Utility Vehicle was tabled until the August meeting.

Dr. Dolliver provided a quick review of the current projects underway at the Pendragon Sports Complex. The scoreboard is expected to be operational by early August; the Restroom/Concession building is moving along quickly, with electrical and plumbing starting soon; the Lift Station has been installed; the

concrete work is all caught up; there is 1-2 days of work left to get the speaker system operational, and the inside of the press box is in the drywall/paint stages, followed by insulation of the ceiling; and lastly will be the gutters and downspout installation.

Dolliver reported meeting with the Facilities Committee recently to review a proposal from Penro Construction to install parking infrastructure. The proposal included site preparation, geo-fabric and 6" of quartzite modified subbase rock; the group agreed that spending this much money on parking was not ideal, but necessary. Dr. Dolliver had also contacted another vendor to just double check the price of the rock and found it nearly \$5 per ton higher without installation. Following questions and discussion, committee members and Superintendent Dolliver recommended approving the proposal from Penro Construction.

A motion was made by Maise and seconded by Heineman to approve the proposal from Penro Construction as reviewed to complete the parking area of the Pendragon Sports Complex at a cost to District of \$191,520.00. President Peters stated the motion and the result of roll call vote being all ayes (6-0), motion carried.

A motion was made by Heineman and seconded by Roth to move into executive session to discuss the rental house located at 611 Whitney Street, and clearly necessary for the protection of the public interest or for the prevention of needless injury to the reputation of an individual in compliance with the law. President Peters stated the motion and the result of roll call vote being all ayes (6-0), motion carried.

President Peters restated the reason for the Executive Session, and the Board entered executive session at 9:41 pm.

A motion to resume the meeting in open session was made by Roth and seconded by Johnson. President Peters stated the motion and the result of roll call vote being all ayes (6-0); motion carried. The Board resumed open session at 10:13 pm.

Board directed Dr. Dolliver to gather more information for the renovations at the 611 Whitney Street rental house.

Board consensus was to hold a final meeting for fiscal year 2024-2025 on Tuesday, August 26, beginning at 7:15 a.m. The primary purpose of the meeting is to approve any final expenditures and to discuss the budget for the 2025-2026 school year.

President Peters reminded Board members of the next regular board meeting scheduled for Monday, August 18 beginning at 8:00 pm and the NASB Area Membership Meeting on August 27th at 5:00 pm in Norfolk. The Board is also invited to the Pre-Service Breakfast and Welcome on August 12th with breakfast at 7:30 am and the Staff Welcome at 8:00 am.

A motion to adjourn was made by Johnson and seconded by Karlen. President Peters stated the motion and the result of the vote being all ayes (6-0) the meeting was adjourned at 10:22 pm.

Jason Roth, Secretary

Deanna Hansen, Recording Secretary

Pender Public Schools
7/25 General Fund Check Report

Check Number	Payee	Type	Amount
741771	Blue Cross Blue Shield of NE	July Payroll Liability	\$72,331.85
741772	Department of Revenue	July Payroll Liability	\$9,565.95
EFT	Employee Benefit Fund	July Payroll Liability	\$3,392.48
741773	Frontier Bank	July Payroll Liability	\$65,142.89
EFT	HSA Account Contributions	July Payroll Liability	\$6,500.85
741774	Madison National Life Ins Co, Inc	July Payroll Liability	\$1,834.59
741775	Nebraska School Retirement	July Payroll Liability	\$42,649.11
741776	Special Building Fund	July Payroll Liability	\$231.67
741777	Trustmark Voluntary Benefits	July Payroll Liability	\$1,545.52
741778	Vision Service Plan	July Payroll Liability	\$586.75
741779	ABC Mobile Storage Inv	Storage Unit Rent	\$175.00
741780	Amazon Capital Services	Accounts Payable	\$1,076.27
741781	Barco Products, LLC	Equipment for PSC FB Field	\$2,295.76
741782	BusRight	License Renewal	\$5,200.00
741783	Carpenter Paper Company	Custodial Supplies	\$702.25
741784	Cubby's	Fuel & Miscellaneous Supplies	\$942.70
741785	Dunn's Plumbing and Heating	Rental House repairs	\$870.00
741786	Eakes Office Solutions	Annual Contract Overage Payment	\$1,222.07
741787	Educational Service Unit #1	Registration Fees	\$75.00
741788	Educational Service Unit #6	Meals Orton Gillingham Training	\$100.00
741789	Educational Service Unit #7	LastPass License Renewal	\$120.00
741790	FileWave (USA) Inc.	Annual License Renewal	\$5,638.00
741791	First National Bank	Accounts Payable	\$2,613.40
741792	Follett Content Solutions LLC	Library Books	\$235.71
741793	FP Mailing Solutions	Postage Meter Rent	\$194.40
741794	Grainger	Ceiling Tiles	\$473.40
741795	Hometown Leasing	Copier Lease Payment	\$1,181.28
741796	J.F. Ahern Co.	Annual Sprinkler Inspection	\$855.00
741797	Jason Sears Flooring	Flooring Removal & Installation	\$27,357.20
741798	Jensen Sprinkler	Annual Sprinkler Inspection	\$925.86
741799	John Deere Financial	Lawn Mower Blades	\$166.02
741800	Kansas City Audio Visual	Technology Equipment	\$12,666.45
741801	Koski, Keith W	Reimbursement	\$60.00
741823	Legacy Leadership LLC	Staff Professional Development	\$1,369.00
741822	Maise Electrical & Mechanical Contracting	Elementary Restroom Remodel	\$9,000.00
741802	Matheson Tri-Gas, Inc.	Welding Gas & Bottle Rent	\$107.45
741803	Midwest Alarm Services	Quarterly Fire Alarm Monitoring	\$150.06
741804	NE Council of School Admin	Registration Fees	\$410.00
741805	NRCSA	Annual Dues 25-26	\$850.00
741806	NREA	Annual Dues 25-26	\$75.00
741807	PanTerra Networks, Inc.	Telephone	\$1,260.89
741808	Pender Ace Hardware	Miscellaneous Maintenance Items	\$731.61
741809	Pender Community Hospital	DOT Physicals	\$525.00
741810	Pender Municipal Utilities	June Usage	\$18,008.79
741811	Petty Cash Fund	Reimbursement	\$151.93
741812	Rays Midbell	Instrumental Music	\$4,601.02
741813	Ricks Computers, Inc.	MacBook Repairs	\$1,024.00
741814	School Specialty, LLC	Science Lab Furniture	\$3,091.50
741815	Staples Advantage	School & Office Supplies	\$166.16
741816	Student Assurance Services	Student Insurance	\$1,140.65
741817	Studies Weekly	Annual Renewal	\$327.50
741818	Sturek Media, Inc.	Printing	\$1,681.92
741824	Teaching Strategies	Nebraska GOLD Renewal	\$470.75
741819	TM Painting & Handyman	Painting Elementary Restrooms	\$2,893.70
741820	Turnitin, LLC	Annual Renewal	\$2,530.57
741821	UnityPoint Clinic-Occupational Medicine	Professional Service	\$42.00
		General Fund PR Liab & AP	\$319,536.93
		General Fund Payroll	\$209,597.43
		School Nutrition Fund	\$36,236.16
		Activity Fund	\$29,643.31
		Special Building Fund	\$167,965.04
		Employee Benefit Fund	\$3,599.94

**PENDER PUBLIC SCHOOL BOARD OF EDUCATION
SPECIAL MEETING MINUTES
Pender Public School – Room #101
July 31, 2025 – 7:15 a.m.**

The Pender Public School Board of Education met in special session in Room #103 on Thursday, July 31, 2025. President Matt Peters called the meeting to order at 7:15 a.m. with the following members present: Jason Roth, J.J. Maise, Matt Peters, Jean Karlen and Mandy Johnson. Absent: Matt Heineman. Also present was Superintendent Jason Dolliver, Secondary Principal Luke Hoffman and Recording Secretary Deanna Hansen.

As required by Nebraska Statute 84-1412(8), President Peters drew the attention of those present to the location of information regarding the Open Meetings Act posted in the meeting room and accessible to all members of the public.

President Peters reviewed the agenda as presented, affirmed that every board member had received notice of the meeting, and confirmed that the time and place of the meeting had been published or posted as required by Board Policy 8342. The meeting notice was posted at Cubby's, Z-Mart, The Pender Times, the Thurston County Court House and Pender Public Schools on July 26, 2025.

A motion was made by Maise and seconded by Roth to excuse Heineman. President Peters stated the motion and the result of roll call vote being all ayes (5-0; Heineman absent), motion carried.

Dr. Dolliver shared two proposals from Nickels Contracting to finish the interior walls of the Timberlyne building. The options were finishing either finishing with drywall or OSB and Tekkor PVC. The Board reviewed the proposals and talked about the pros and cons of each option, and which one would be more durable in the long run. Superintendent Dolliver recommended approving the proposal to finish with the OSV and Tekkor PVC.

A motion to approve the proposal from Nickels Contracting to finish the interior walls of the RR/Concession Building with OSB and Tekkor PVC at a cost of \$33,300.00 was made by Maise and seconded by Johnson. President Peters stated the motion and the result of roll call vote being all ayes (5-0), motion carried.

Superintendent Dolliver talked with the Board about the options for getting the scoreboard connected to the press box. The board reviewed the proposal and asked questions. Dr. Dolliver recommended approving the proposal from CDB Utility Contractors.

A motion to approve the proposal from CDB Utility Contractors at a cost up to \$19,889.75 to connect the scoreboard to the press box via boring in underground fiber was made by Maise and seconded by Roth. President Peters stated the motion and the result of roll call vote being all ayes (5-0), motion carried.

Dr. Dolliver talked about the improvements needed at the 611 Whitney rental house. He shared he never received a proposal from Service Master for cleanup of the house; that he had received 2 proposals from Creative Carpets to install new flooring on the first floor; and a proposal for replacing the deck. The Board talked about the proposals and the options for the getting the work completed. Dr. Dolliver recommended approving the second quote from Creative Carpets and approving up to \$5600 for the deck project.

A motion to approve the proposal from Creative Carpets to replace all the flooring on the first floor in the 611 Whitney Street rental house, up to a cost of \$6536.78 was made by Maise and seconded by Johnson. President Peters stated the motion and the result of roll call vote being all ayes (5-0), motion carried.

A motion to approve the proposal to replace the deck on the 611 Whitney rental house at a cost up to \$5600.00 was made by Maise and seconded by Johnson. President Peters stated the motion and the result of roll call vote being all ayes (5-0), motion carried.

President Peters reminded those in attendance of the next regular Board Meeting on Monday, August 18, 2025 at 8:00 pm and the NSAB Area Membership Meeting on August 26, 2025, in Norfolk.

A motion to adjourn was made by Maise and seconded by Roth. President Peters stated the motion and the result of roll call vote being all ayes (5-0), the meeting was adjourned at 7:40 am.

Jason Roth, Secretary

Deanna Hansen, Recording Secretary

Pender Public Schools

Financial Report
August 18, 2025

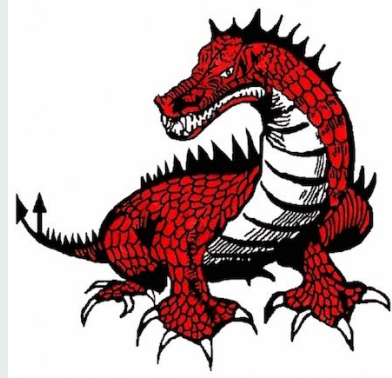



Purpose

- Draw attention to district finance in a way that is more engaging for Board members and anyone who happens to be in attendance
- Infuse more discussion about district finance into monthly Board meeting
 - Designed to be something in addition to the questions and comments made when the checks are approved
- Create a historical catalog, which will be helpful in many ways



New to this report ...

- Payroll and payroll liabilities total from the same month from prior years
- The intent of this is to give Board Members an idea of how costs are rising over time
- General Fund and School Nutrition Fund ... not Activities Fund

**FINANCIAL REPORT FOR JULY 2025
SCHOOL NUTRITION FUND #346217**

Balance - June 30, 2025		78,686.00
Student Breakfast/Lunch	260.00	
Adult Breakfast/Lunch		
Federal Reimbursement (13 days)		
Federal SFSP Reimbursement (4 days)		
State Breakfast/Lunch Reimbursement		
LFS Grant Reimbursement	3,181.27	
Insufficient Fund Check Students		
Other Receipts	649.06	
Interest	45.81	
TOTAL REVENUE		4,136.14
Accounts Payable	16,213.26	
Payroll	9,943.94	
Payroll Liabilities	10,078.96	
TOTAL EXPENDITURES		36,236.16
Reconciled Balance - July 31, 2025		<u>\$ 46,585.98</u>

	<i>PR & PR Liab</i>	
<i>Reconciled Balance - July 31, 2024</i>	<i>22,327.93</i>	<i>\$ 100,513.87</i>
<i>Reconciled Balance - July 31, 2023</i>	<i>22,687.23</i>	<i>\$ 130,965.05</i>
<i>Reconciled Balance - July 31, 2022</i>	<i>7,061.91</i>	<i>\$ 206,708.37</i>
<i>Reconciled Balance - June 30, 2021</i>	<i>15,901.78</i>	<i>\$ 133,810.41</i>
<i>Reconciled Balance - July 30, 2020</i>	<i>16,651.01</i>	<i>\$ 67,321.95</i>
<i>Reconciled Balance - July 30, 2019</i>	<i>6,942.96</i>	<i>\$ 39,738.57</i>
<i>Reconciled Balance - July 30, 2018</i>	<i>6,722.58</i>	<i>\$ 40,291.25</i>
<i>Reconciled Balance - July 30, 2017</i>		<i>\$ 39,252.22</i>
<i>Reconciled Balance - July 30, 2016</i>		<i>\$ 47,779.10</i>
<i>Reconciled Balance - July 30, 2015</i>		<i>\$ 37,781.70</i>



School Nutrition Fund

- Revenue from June has NOT been received, which makes this report quite deceiving
- \$41,405.73 will be received; it is simply a matter of when
- \$119,842.27 is what the balance should be if this revenue were have to been received (like it should have been)
- In June, our revenue exceeded our bills by about \$10,000

FINANCIAL REPORT FOR JULY 2025
ACTIVITY FUND #346195

Checking Account Balance - June 30, 2025		51,025.50
Certificates of Deposit Balance - June 30, 2025		84,283.09
		<u>135,308.59</u>
Activity Revenue	13,338.33	
Interest Earned	<u>35.01</u>	
TOTAL REVENUE		13,373.34
Activity Expenses	<u>19,045.03</u>	
TOTAL EXPENDITURES		19,045.03
Checking Account Balance - July 31, 2025		45,353.81
Certificates of Deposit Balance - July 31, 2025		84,283.09
		<u><u>129,636.90</u></u>
<i>Reconciled Balance - July 31, 2024</i>		<i>\$ 132,103.40</i>
<i>Reconciled Balance - July 31, 2023</i>		<i>\$ 143,510.35</i>
<i>Reconciled Balance - July 31, 2022</i>		<i>\$ 135,478.80</i>
<i>Reconciled Balance - July 29, 2021</i>		<i>\$ 138,186.64</i>
<i>Reconciled Balance - July 29, 2020</i>		<i>\$ 146,583.11</i>
<i>Reconciled Balance - July 29, 2019</i>		<i>\$ 127,800.57</i>
<i>Reconciled Balance - July 29, 2018</i>		<i>\$ 104,920.08</i>
<i>Reconciled Balance - July 29, 2017</i>		<i>\$ 115,658.95</i>
<i>Reconciled Balance - July 29, 2016</i>		<i>\$ 138,469.52</i>
<i>Reconciled Balance - July 29, 2015</i>		<i>\$ 133,471.58</i>

**FINANCIAL REPORT FOR JULY 2025
GENERAL FUND #41-200-7**

Balance - June 30, 2025		4,495,642.17
Taxes Levied (County Proceeds)	75,334.54	
23-24 SPED SA Reimbursement		
State Aid		
SPED SA Transportation 23-24		
SON SN24 MAC		
SON JA24 MIPS		
ESU Proceeds	3,364.06	
SON 23-24 Title I Reimbursement		
Other Local Receipts	1,159.00	
Interest Earned	7,143.87	
TOTAL REVENUE		87,001.47
Accounts Payable	115,762.77	
Payroll	209,597.43	
Payroll Liabilities	203,781.66	
TOTAL EXPENDITURES		529,141.86
Checking & Super Sweep & CD		
Reconciled Balance - July 31, 2025		<u>\$ 4,053,501.78</u>
	<i>PR & PR Liab</i>	
<i>Reconciled Balance - July 31, 2024</i>	<i>411,445.07</i>	<i>\$ 2,822,723.77</i>
<i>Reconciled Balance - July 31, 2023</i>	<i>413,078.66</i>	<i>\$ 2,471,259.83</i>
<i>Reconciled Balance - July 31, 2022</i>	<i>384,696.56</i>	<i>\$ 2,346,422.45</i>
<i>Reconciled Balance - June 30, 2021</i>	<i>371,024.53</i>	<i>\$ 1,877,125.68</i>
<i>Reconciled Balance - July 30, 2020</i>	<i>344,866.73</i>	<i>\$ 1,270,584.39</i>
<i>Reconciled Balance - July 30, 2019</i>	<i>340,822.26</i>	<i>\$ 1,227,722.70</i>
<i>Reconciled Balance - July 30, 2018</i>	<i>329,054.52</i>	<i>\$ 1,420,950.24</i>
<i>Reconciled Balance - July 30, 2017</i>		<i>\$ 1,222,638.64</i>
<i>Reconciled Balance - July 30, 2016</i>		<i>\$ 1,405,342.62</i>
<i>Reconciled Balance - July 30, 2015</i>		<i>\$ 1,546,320.49</i>

Pender Public Schools

8/25 General Fund Check Report

Check Number	Payee	Type	Amount
41825	Blue Cross Blue Shield of NE	August Payroll Liability	\$72,331.85
41826	Department of Revenue	August Payroll Liability	\$10,235.99
EFT	Employee Benefit Fund	August Payroll Liability	\$3,390.02
41827	Frontier Bank	August Payroll Liability	\$68,689.18
EFT	HSA Account Contributions	August Payroll Liability	\$6,500.85
41828	Madison National Life Ins Co, Inc	August Payroll Liability	\$1,829.27
41829	Nebraska School Retirement	August Payroll Liability	\$43,392.40
41830	Pender General Fund	August Payroll Liability	\$66.00
41831	Special Building Fund	August Payroll Liability	\$81.67
41832	Trustmark Voluntary Benefits	August Payroll Liability	\$1,545.52
41833	Vision Service Plan	August Payroll Liability	\$586.45
41834	ABC Mobile Storage Inc	Storage Unit Rent	\$175.00
41835	Amazon Capital Services	Accounts Payable	\$2,730.35
41836	Apothecary Shop	Epi Pens & Albuterol	\$570.37
41837	Appearia	Rug Rent	\$113.55
41838	Apptegy	Thrillshare Renewal	\$3,700.00
41839	AT&T Mobility	MiFi Box for AD	\$80.16
41840	Clever Inc.	Renewal	\$1,350.00
41841	Cole Papers	Custodial Supplies	\$270.69
41842	CPI	Training Workbooks	\$998.70
41843	Creative Carpets	Flooring & Installation	\$6,536.78
41844	Crouch Recreational Design, Inc.	Shades	\$7,018.00
41845	Cubby's	Fuel & Miscellaneous	\$392.54
41846	Educational Service Unit #1	Purchased Services	\$90,972.11
41847	Essential Screens	Background Checks	\$83.00
41848	ESU Coordinating Council	Fortimail	\$311.61
41849	First National Bank	Accounts Payable	\$3,593.95
41850	Follett Content Solutions LLC	Library Books	\$3,179.76
41851	Follett School Solutions, Inc.	Library Software Renewal	\$1,194.40
41852	FP Mailing Solutions	Ink for Postage Machine	\$292.10
41853	Frontier Bank	Cash for Car Wash for School Vehicles	\$250.00
41854	Grainger	Ceiling Tiles	\$189.36
41855	Hands of Heartland	Transition Services	\$778.44
41856	Harris School Solutions	Aptafund Annual Software Renewal	\$10,820.29
41857	Hauff Mid-America Sports	Football Equipment for PSC	\$879.75
41858	Hometown Leasing	Copier Lease	\$1,181.28
41859	HR Direct	Labor Poster Service	\$97.95
41860	Hudl	Annual Renewal	\$7,500.00
41861	Innovative Office Solutions, LLC	Classroom & Office Supplies	\$494.40
41862	J.W. Pepper & Son, Inc.	Choir Music	\$173.49
41863	JourneyEd, Inc.	Adobe License Renewal	\$500.00
41864	Kansas City Audio Visual	Rise Vision Service	\$656.00
41865	Kings Disposal Co	Trash Removal	\$9,288.00
41866	Lorensen Lumber & Grain	Maintenance Supplies	\$60.18
41867	Maise Electrical & Mechanical Contractor	Elementary Restrooms	\$3,000.00
41868	Matheson Tri-Gas, Inc.	Welding Gas & Bottle Rent	\$110.60
41869	Menards Sioux City	Maintenance & Custodial Supplies	\$1,182.36
41870	NASB ALICAP	25/26 Insurance Premium	\$101,534.00
41871	Nebraska Safety Center	Student Transportation Training	\$520.00
41872	Orkin Pest Control	Pest Control	\$2,522.76
41873	PanTerra Networks, Inc.	Telephone	\$1,269.39
41874	Pender Ace Hardware	Miscellaneous Supplies	\$1,342.30
41875	Pender Activity Fund	Reimbursement	\$26,880.90
41876	Pender Community Hospital	DOT Physical and Lab Fees	\$364.00
41894	Pender Depreciation Fund	Budgeted Transfer	\$110,000.00
41878	Pender Grain Inc	Weed Spray	\$387.50
41879	Pender Municipal Utilities	July Usage	\$17,249.25

41880	Pender School Nutrition Fund	Reimbursement	\$545.86
41881	Petty Cash Fund	Reimbursement	\$1,568.75
41882	Phillips' Floors, Inc.	BB Hoop Inspections	\$3,588.66
41883	PowerSchool Group LLC	Annual Renewal	\$6,804.24
41884	Quill Corporation	Office Supplies	\$9.19
41885	Rasmussen Mechanical Services	Air Handler Repairs	\$7,930.00
41886	Rays Midbell	Instrumental Music Supplies	\$229.99
41887	Scholastic Inc	Classroom Supplies	\$467.51
41888	School Specialty, LLC	Classroom Supplies	\$59.54
41889	Silver Silo Design & Print	Printing & Envelopes	\$1,005.00
41890	Sturek Media, Inc.	Printing	\$1,134.98
41891	Sundys Auto Parts	Maintenance Supplies	\$22.49
41892	Teaching Strategies, Inc.	GOLD Software Renewal	\$470.75
41895	Turf Tank	Year 2 License Fee	\$6,000.00
		GF Payroll Liabilities & Accounts Payable	\$661,281.43
		GF Payroll	\$219,272.52
		School Nutrition Fund Total	\$36,986.26
		Activity Fund Total	\$19,045.03
		Employee Benefit Fund Total	\$3,599.94
		Special Building Fund Total	\$122,043.19

Pender Public Schools

8/25 School Nutrition Fund Check Report

Check Number	Payee	Description	Amount
9080	Blue Cross Blue Shield of NE	August Payroll Liability	\$4,955.45
9081	Credit Management Services, Inc.	August Payroll Liability	\$159.38
9082	Department of Revenue	August Payroll Liability	\$237.77
EFT	Employee Benefit Fund	August Payroll Liability	\$209.92
9083	Frontier Bank	August Payroll Liability	\$2,165.88
EFT	HSA Account Contributions	August Payroll Liability	\$396.37
9084	Madison National Life Ins Co, Inc	August Payroll Liability	\$42.09
9085	Nebraska School Retirement	August Payroll Liability	\$2,017.66
9086	Vision Service Plan	August Payroll Liability	\$43.36
9087	Amazon Capital Services	Mop Bucket, Handle and Mop Heads	\$126.87
9088	Cash-Wa Distributing Co	Food and Supplies for Kitchen	\$5,622.85
9089	Cubbys	Fuel for SFSP Meal Delivery	\$194.55
9090	Hiland Dairy Foods Company, LLC	Milk Products	\$2,134.17
9091	KL Beef	Ground Beef	\$2,840.00
9092	Strachan Sales, Inc.	Kitchen Equipment Inspection & Service	\$599.91
9093	Sysco Lincoln	Food and Supplies for Kitchen	\$5,569.63
		SNF Payroll Liabilities & Accounts Payable	\$27,315.86
		SNF Payroll	\$9,670.40
		SNF Total	\$36,986.26

Pender Public Schools

8/25 Special Building Fund Check Report

Check Number	Payee	Description	Amount
1095	Amazon Capital Services	LED Lights with battery backup; 6-pack channel drain w/grates	\$1,313.74
1096	Guarantee Roofing, Siding & Insulation	preschool roof replacement	\$27,709.00
1097	Jerico Construction LLC	concrete & supplies for PSC	\$20,000.00
1098	Maise Electrical & Mechanical Contractor	Pay App #2 for PSC (electrical)	\$10,000.00
1099	Nickels Contracting	Pay App #2 Bid 180 & Pay App #1 Bid 205 (all bids for construction of and finishing Timberlyne building at PSC)	\$32,847.50
1100	Renz Electric & Plumbing, Inc.	Pay App #1 and #2, plus Extra's for PSC (all plumbing work)	\$30,172.95
			\$122,043.19

Check Detail

Sorted by Activity ID, Site ID.
From 07/01/2025 to 07/31/2025.

Activity ID Site ID Check # Status	Activity Name Site Name Issue Date Status Date	Vendor Name PO Number	1099?	Invoice Number	Approved by Description	Amount
<hr/> 1000 Operations <hr/>						
PPS Pender Public Schools						
046493 Cleared	07/14/2025 07/31/2025	First National Bank of Omaha	No	DH-6740-7/25	Deanna Hansen photo for athletic dept	20.06
046498 Printed	07/14/2025 07/14/2025	Port-A-Johns	No	25-2869	Deanna Hansen portable restroom rent June	75.00
Total for PPS - Pender Public Schools:						95.06
Total for 1000 - Operations:						95.06
<hr/> 110 BOYS BASKETBALL <hr/>						
PPS Pender Public Schools						
046499 Printed	07/14/2025 07/14/2025	Shoot A Way, Inc 2425067	No	Parts0402-9	Deanna Hansen 8000 Replacement Wand	177.50
<hr/> 120 FOOTBALL <hr/>						
PPS Pender Public Schools						
046493 Cleared	07/14/2025 07/31/2025	First National Bank of Omaha 2425198	No	CV-4784-7/25	Deanna Hansen New waterer for football practice	428.00
046495 Cleared	07/14/2025 07/31/2025	Hauff Mid-America Sports 2425062	No	162992	Deanna Hansen 8 shoulder pads	1,760.00
Total for PPS - Pender Public Schools:						2,188.00
Total for 120 - FOOTBALL:						2,188.00
<hr/> 125 GIRLS BASKETBALL <hr/>						
PPS Pender Public Schools						
046491 Cleared	07/14/2025 07/31/2025	Awards Unlimited, Inc. No		15474	Deanna Hansen head coach award plate, champ trophy plate	76.51
046499 Printed	07/14/2025 07/14/2025	Shoot A Way, Inc 2425067	No	Parts0402-9	Deanna Hansen 8000 Replacement Wand	177.50
046499 Printed	07/14/2025 07/14/2025	Shoot A Way, Inc 2425067	No	Parts0402-9	Deanna Hansen 8000 Replacement Wand	-15.00
Total for PPS - Pender Public Schools:						239.01
Total for 125 - GIRLS BASKETBALL:						239.01

Check Detail

Sorted by Activity ID, Site ID.
From 07/01/2025 to 07/31/2025.

Activity ID Site ID	Activity Name Site Name	Check # Status	Issue Date Status Date	Vendor Name PO Number	1099? Invoice Number	Approved by Description	Amount
<hr/> 125-F Girls Basketball Fundraising <hr/>							
PPS	Pender Public Schools						
046493 Cleared	07/14/2025 07/31/2025	First National Bank of Omaha		No	JD-8509-7/25	Deanna Hansen GBB lodging for KC tourney	815.88
<hr/> 160 JH WRESTLING <hr/>							
PPS	Pender Public Schools						
046501 Printed	07/22/2025 07/22/2025	Awards Unlimited, Inc.		No	308975	Deanna Hansen wrestling plaques & trophies	247.01
<hr/> 165 VOLLEYBALL <hr/>							
PPS	Pender Public Schools						
046495 Cleared	07/14/2025 07/31/2025	Hauff Mid-America Sports		No	172167	Deanna Hansen games balls for 25/26 school year	300.00
<hr/> 165-F Volleyball Fundraising <hr/>							
PPS	Pender Public Schools						
046486 Cleared	07/02/2025 07/31/2025	Wayne Community Schools		No	07022025vb	Deanna Hansen July 8 volleyball camp reg fee	160.00
046502 Cleared	07/22/2025 07/31/2025	Jordan Larson		No	07222025vbf	Deanna Hansen July 26th VB camp clinician fee	560.00
Total for PPS - Pender Public Schools:							720.00
Total for 165-F - Volleyball Fundraising:							720.00
<hr/> 170 HS WRESTLING <hr/>							
PPS	Pender Public Schools						
046501 Printed	07/22/2025 07/22/2025	Awards Unlimited, Inc.		No	308975	Deanna Hansen wrestling plaques & trophies	160.83

Check Detail

Sorted by Activity ID, Site ID.
From 07/01/2025 to 07/31/2025.

Activity ID	Activity Name					Approved by	
Site ID	Site Name	Issue Date	Vendor Name	1099?	Invoice Number	Description	Amount
Check #	Status Date	PO Number					
<hr/>							
170-F	HS Wrestling Fundraising						
<hr/>							
PPS	Pender Public Schools						
046493	07/14/2025	First National Bank of Omaha				Deanna Hansen	
Cleared	07/31/2025	2425201	No	DH-6740-7/25.2	Hotel Room for Camp Coach		79.00
046493	07/14/2025	First National Bank of Omaha				Deanna Hansen	
Cleared	07/31/2025		No	DH-6740-7/25.3	wrestling camp at Crete 1 room 1 night		99.00
Total for PPS - Pender Public Schools:							178.00
Total for 170-F - HS Wrestling Fundraising:							178.00
<hr/>							
185	CROSS COUNTRY						
<hr/>							
PPS	Pender Public Schools						
046491	07/14/2025	Awards Unlimited, Inc.				Deanna Hansen	
Cleared	07/31/2025		No	308972	plaques & awards for 25-26		305.38
<hr/>							
290	CLASS OF 2026						
<hr/>							
PPS	Pender Public Schools						
046497	07/14/2025	Pender Ace Hardware				Deanna Hansen	
Cleared	07/31/2025	2425202	No	59045	Griddles		892.00
046497	07/14/2025	Pender Ace Hardware				Deanna Hansen	
Cleared	07/31/2025	2425219	No	59298	Spatulas and tongs for griddle		97.97
046497	07/14/2025	Pender Ace Hardware				Deanna Hansen	
Cleared	07/31/2025	2425202	No	59045	Griddles		39.97
Total for PPS - Pender Public Schools:							1,029.94
Total for 290 - CLASS OF 2026:							1,029.94

Check Detail

Sorted by Activity ID, Site ID.
From 07/01/2025 to 07/31/2025.

Activity ID Site ID Check # Status	Activity Name Site Name Issue Date Status Date	Vendor Name PO Number	1099?	Invoice Number	Approved by Description	Amount
<hr/> 291 CLASS OF 2027 <hr/>						
PPS	Pender Public Schools					
046492 Cleared	07/14/2025 07/31/2025	Cubby's 2425207	No	1042668	Deanna Hansen misc expenses for Pancake feed	-28.04
046492 Cleared	07/14/2025 07/31/2025	Cubby's 2425207	No	1042668	Deanna Hansen misc expenses for Pancake feed	50.00
046493 Cleared	07/14/2025 07/31/2025	First National Bank of Omaha	No	LJ-4921-7/25	Deanna Hansen oil and syrup for pancake feed	25.90
046500 Cleared	07/14/2025 07/31/2025	Sturek Media, Inc. 2425208	No	06302025	Deanna Hansen Ad for Pancake feed	35.00
046500 Cleared	07/14/2025 07/31/2025	Sturek Media, Inc. 2425208	No	06302025	Deanna Hansen Ad for Pancake feed	-2.40
046504 Cleared	07/23/2025 07/31/2025	Pender School Nutrition Fund 2425209	No	05092025	Deanna Hansen Pam's order for pancake feed	-204.14
046504 Cleared	07/23/2025 07/31/2025	Pender School Nutrition Fund 2425209	No	05092025	Deanna Hansen Pam's order for pancake feed	800.00
Total for PPS - Pender Public Schools:						676.32
Total for 291 - CLASS OF 2027:						676.32

<hr/> 315-F Instrumental Music Fundraising <hr/>						
PPS	Pender Public Schools					
046491 Cleared	07/14/2025 07/31/2025	Awards Unlimited, Inc. No		308972	Deanna Hansen plaques & awards for 25-26	42.89
046501 Printed	07/22/2025 07/22/2025	Awards Unlimited, Inc. No		318386	Deanna Hansen battle of the bands trophy	7.71
Total for PPS - Pender Public Schools:						50.60
Total for 315-F - Instrumental Music Fundraising:						50.60

<hr/> 345 STUDENT COUNCIL <hr/>						
PPS	Pender Public Schools					
046493 Cleared	07/14/2025 07/31/2025	First National Bank of Omaha	No	SK-8626-7/25	Deanna Hansen flowers for Kinning funeral	42.80

Check Detail

Sorted by Activity ID, Site ID.
From 07/01/2025 to 07/31/2025.

Activity ID Site ID Check # Status	Activity Name Site Name Issue Date Status Date	Vendor Name PO Number	1099? Yes	Invoice Number	Approved by Description	Amount
<hr/> 350 VOCAL MUSIC <hr/>						
PPS	Pender Public Schools					
046487 Cleared	07/02/2025 07/31/2025	The Musicians Choice, LLC 2425171	Yes	9597	Deanna Hansen All State Music 2025	222.90
<hr/> 365 CLOSE-UP <hr/>						
PPS	Pender Public Schools					
046493 Cleared	07/14/2025 07/31/2025	First National Bank of Omaha	No	DH-6740-7/25.4	Deanna Hansen Closeup Deposits	4,750.00
<hr/> 450 F&R Sponsor Pd by District <hr/>						
PPS	Pender Public Schools					
046489 Cleared	07/02/2025 07/31/2025	Candlewood Suites	No	07022025tr	Deanna Hansen 06-11-25 PPS State Track Lodging	1,620.00
<hr/> 530-F Flames Fundraising <hr/>						
PPS	Pender Public Schools					
046493 Cleared	07/14/2025 07/31/2025	First National Bank of Omaha	No	LH-0979-7/25	Deanna Hansen color powder for color run	192.52
046493 Cleared	07/14/2025 07/31/2025	First National Bank of Omaha	No	KS-2321-7/25	Deanna Hansen powder for color run	69.99
046493 Cleared	07/14/2025 07/31/2025	First National Bank of Omaha	No	KS-2321-7/25.2	Deanna Hansen bottled water for color run/watermelon days	6.58
046493 Cleared	07/14/2025 07/31/2025	First National Bank of Omaha	No	KS-2321-7/25	Deanna Hansen powder for color run	-1.09
046503 Cleared	07/22/2025 07/31/2025	Stadium Sports	No	70816	Deanna Hansen dance team tshirts	154.00
Total for PPS - Pender Public Schools:						422.00
Total for 530-F - Flames Fundraising:						422.00
<hr/> 710 STATE CONTEST <hr/>						
PPS	Pender Public Schools					
046489 Cleared	07/02/2025 07/31/2025	Candlewood Suites	No	07022025tr	Deanna Hansen 06-11-25 PPS State Track Lodging	1,296.00

Check Detail

Sorted by Activity ID, Site ID.
From 07/01/2025 to 07/31/2025.

Activity ID	Activity Name				Approved by	
Site ID	Site Name	Vendor Name	1099?	Invoice Number	Description	Amount
Check #	Issue Date	PO Number				
Status	Status Date					
<hr/>						
985	NEN Vipers Softball Co-op					
<hr/>						
PPS	Pender Public Schools					
046493	07/14/2025	First National Bank of Omaha			Deanna Hansen	
Cleared	07/31/2025	2425211	No	CH-7204-7/25	softball bat	499.00
046493	07/14/2025	First National Bank of Omaha			Deanna Hansen	
Cleared	07/31/2025	2425211	No	CH-7204-7/25	softball bat	0.99
046496	07/14/2025	Hauff Sports Omaha			Deanna Hansen	
Cleared	07/31/2025	2425218	No	176179	catcher's set	20.00
046496	07/14/2025	Hauff Sports Omaha			Deanna Hansen	
Cleared	07/31/2025	2425218	No	176179	catcher's set	345.00
Total for PPS - Pender Public Schools:						864.99
Total for 985 - NEN Vipers Softball Co-op:						864.99
<hr/>						
985-F	NEN Vipers Softball Coop - Fundraising					
<hr/>						
PPS	Pender Public Schools					
046488	07/02/2025	Boombah, LLC			Deanna Hansen	
Cleared	07/31/2025	2425204	No	187537	softball bags	2,515.22
046493	07/14/2025	First National Bank of Omaha			Deanna Hansen	
Cleared	07/31/2025	2425217	No	CH-7204-7/25.2	softball patches	104.29
046493	07/14/2025	First National Bank of Omaha			Deanna Hansen	
Cleared	07/31/2025	2425217	No	CH-7204-7/25.2	softball patches	23.30
Total for PPS - Pender Public Schools:						2,642.81
Total for 985-F - NEN Vipers Softball Coop - Fundraising:						2,642.81
Grand Total :						19,045.03

Pender Public Schools

8/25 Vendor Report - Amazon

Payee	PO #	Description	Amount
Amazon Capital Services		2 black poster frames	\$51.98
Amazon Capital Services		coffee	\$94.60
Amazon Capital Services		custodial supplies-restroom signs, dispensers, bathroom receptacles	\$395.70
Amazon Capital Services		double sided tape, self-adhesive magnetic wall sign holders	\$65.27
Amazon Capital Services		easel pads	\$76.59
Amazon Capital Services		supplies	\$152.98
Amazon Capital Services		supplies-Principal Hoffman	\$33.98
Amazon Capital Services		7 toilet paper dispensers	\$257.95
Amazon Capital Services		2" dry-core drill bit for brick and block	\$44.98
Amazon Capital Services		ether net media converters with dual transceiver module	\$54.41
Amazon Capital Services		8 mini blinds for 611 Whitney rental house	\$178.88
Amazon Capital Services	24/25--272	From Your Biggest Fan - Book	\$16.09
Amazon Capital Services	24/25--272	The Anxious Generation - Book	\$11.32
Amazon Capital Services	24/25--272	Uncommon Favor - Book	\$9.37
Amazon Capital Services	24/25--271	Anker USB C Hub, 5-in-1 USBC to HDMI Splitter with 4K Display, 1 x Powered USB-C 5Gbps & 2x Powered USB-A 3.0 5Gbps Data Ports for MacBook Pro, MacBook Air, Dell and More	\$37.58
Amazon Capital Services	24/25--271	VELCRO Brand Extreme Outdoor Double Sided Mounting Tape Holds up to 15 Pounds on Brick or Other Rough Surfaces UV and Weather Resistant 14Ft Heavy Duty Roll	\$18.99
Amazon Capital Services	24/25--270	Book: From Your Biggest Fan	\$31.98
Amazon Capital Services	24/25--269	USB Type C to 3.5mm 4pack Female Headphone Jack Adapter: Type C to Aux Audio Cable Cord Compatible with Samsung Galaxy S22+ S21 Ultra S20 S10 S9 Note 20 10, Google Pixel 6 Pro/5/4/3/2	\$169.80
Amazon Capital Services	24/25--269	6U Wall Mount Rack Open Frame 19 Inch Server Equipment Network Cabinet 18 inches Depth Black by Tedgetal	\$71.20
Amazon Capital Services	24/25--265	10FT Surge Protector Power Strip, Flat Extension Cord with 2 USB C, Flat Plug Power Strip, 4 Widely Outlets and 4 USB Charging Ports, Outlet Extender, 900 Joules, for Home Office Dorm Room Essentials	\$51.96
Amazon Capital Services	24/25--264	32Ft *1 Inch Hook and Loop Tape with Adhesive Back, Heavy Duty Double Sided Adhesive Strips, Strong Sticky Strips Roll for Home/Office/School/Car, Black	\$7.99
Amazon Capital Services	24/25--264	Cable Clips for Cable Management Cord Organizer, 6 Sizes 300 PCS Nylon R-Type, 3/16" 1/4" 3/8" 1/2" 3/4" 1" Black Plastic Screw Mounting Cord Fastener Clamp Assortment Kit with M4 Screws	\$12.80
Amazon Capital Services	24/25--264	returned hook and loop tape	(\$10.94)
Amazon Capital Services	24/25--264	Shipping	\$6.99
Amazon Capital Services	24/25--277	12 timers	\$19.99
Amazon Capital Services	24/25--277	36" x 48" mobile dry-erase double sided white board	\$103.55
Amazon Capital Services	24/25--277	7 staple removers	\$8.99
Amazon Capital Services	24/25--277	Magnetic 7.5" countdown timer	\$18.99
Amazon Capital Services	24/25--277	Mobile foldable standing desk	\$109.99
Amazon Capital Services	24/25--276	GearIT Cat 6 Ethernet Cable (10-Pack 20 Feet) Cat6 Network Patch, 10Gbps, RJ45, Snagless Cord, Gold-Plated Connectors, Internet for PC, TV, Tablet, Router, Printer, Servers, IT Data Center - Black	\$33.79
Amazon Capital Services	24/25--276	GEARit Cat 6 Ethernet Cable (5-Pack 20 Feet) Cat6 Network Patch, 10Gbps, RJ45, Snagless Cord, Gold-Plated Connectors, Internet for PC, TV, Tablet, Router, Printer, Servers, IT Data Center - Blue	\$75.93

Amazon Capital Services	24/25--275	ASUS Intel NUC KIT Business Mini Desktop, 16GB DDR4 RAM, 512GB SSD, Intel Celeron Processor, Wi-Fi Ready, Bluetooth, RJ45, Dual HDMI, 4K UHD, SD Card Reader, USB 3.0, Windows 11 Pro	\$278.99
Amazon Capital Services	24/25--275	KOORUI 24-inch Computer Monitor Full HD 1920 x 1080p 100Hz VA Display 3000:1 Contrast Ratio with HDMI VGA, Three-Sided Slim Bezels, Freesync, 100 x 100 mm VESA Mountable, Ergonomic Tilt, Black	\$79.98
Amazon Capital Services	24/25--274	Back to school balloon arch red/black/white	\$43.60
Amazon Capital Services	24/25--274	Back to school balloon garland	\$14.99
Amazon Capital Services	24/25--274	Back to school Decoration	\$16.99
Amazon Capital Services	24/25--274	Balloon arch stand kit	\$17.99
Amazon Capital Services	24/25--274	Balloon Selfie School Bus	\$31.58
Amazon Capital Services	24/25--274	Portable balloon inflator	\$27.98
Amazon Capital Services	24/25--274	Shipping	\$4.57
Sub Total			\$2,730.35

Pender Municipal Utility Bills/Averages

Year	Month	Natural Gas	Electricity	FB Elec/Water	Water/Sewer	Total
2025	January	\$ 6,981.36	\$ 10,492.41	\$ 194.61	\$ 460.10	\$ 18,128.48
2025	February	\$ 6,784.60	\$ 9,978.89	\$ 194.61	\$ 515.58	\$ 17,473.68
2025	March	\$ 3,568.98	\$ 10,228.59	\$ 194.49	\$ 406.97	\$ 14,399.03
2025	April	\$ 4,020.97	\$ 11,695.58	\$ 924.83	\$ 432.74	\$ 17,074.12
2025	May	\$ 843.03	\$ 16,105.30	\$ 2,897.63	\$ 243.55	\$ 20,089.51
2025	June	\$ 624.23	\$ 15,508.46	\$ 1,476.19	\$ 399.91	\$ 18,008.79
2025	July	\$ 393.77	\$ 15,768.09	\$ 670.67	\$ 416.72	\$ 17,249.25
2025	August					\$ -
2025	September					\$ -
2025	October					\$ -
2025	November					\$ -
2025	December					\$ -
2025	TOTAL	\$ 23,216.94	\$ 89,777.32	\$ 6,553.03	\$ 2,875.57	\$ 122,422.86
2025	MO. AVERAGE	\$ 3,316.71	\$ 12,825.33	\$ 936.15	\$ 410.80	\$ 17,488.98
Year	Month	Natural Gas	Electricity	FB Elec/Water	Water/Sewer	Total
2024	January	\$ 8,370.85	\$ 9,103.85	\$ 161.90	\$ 297.06	\$ 17,933.66
2024	February	\$ 5,473.94	\$ 10,480.70	\$ 160.67	\$ 431.98	\$ 16,547.29
2024	March	\$ 6,330.75	\$ 9,832.51	\$ 120.95	\$ 437.59	\$ 16,721.80
2024	April	\$ 4,464.93	\$ 10,936.59	\$ 734.91	\$ 360.71	\$ 16,497.14
2024	May	\$ 2,045.45	\$ 13,604.66	\$ 616.05	\$ 335.46	\$ 16,601.62
2024	June	\$ 1,085.01	\$ 13,290.27	\$ 1,029.65	\$ 228.94	\$ 15,633.87
2024	July	\$ 1,155.48	\$ 14,022.09	\$ 1,308.42	\$ 244.97	\$ 16,730.96
2024	August	\$ 1,423.15	\$ 16,537.60	\$ 1,270.55	\$ 313.63	\$ 19,544.93
2024	September	\$ 1,510.62	\$ 17,002.78	\$ 644.58	\$ 428.83	\$ 19,586.81
2024	October	\$ 2,293.74	\$ 15,491.21	\$ 883.98	\$ 419.36	\$ 19,088.29
2024	November	\$ 2,624.90	\$ 10,977.92	\$ 194.98	\$ 419.30	\$ 14,217.10
2024	December	\$ 6,284.09	\$ 9,965.41	\$ 194.85	\$ 457.69	\$ 16,902.04
2024	TOTAL	\$ 43,062.91	\$ 151,245.59	\$ 7,321.49	\$ 4,375.52	\$ 206,005.51
2024	MO. AVERAGE	\$ 3,588.58	\$ 12,603.80	\$ 610.12	\$ 364.63	\$ 17,167.13
Year	Month	Natural Gas	Electricity	FB Elec/Water	Water/Sewer	Total
2023	January	\$ 4,718.83	\$ 8,192.30	\$ 160.55	\$ 290.29	\$ 13,361.97
2023	February	\$ 3,695.79	\$ 10,265.66	\$ 162.63	\$ 413.65	\$ 14,537.73
2023	March	\$ 8,474.60	\$ 7,757.32	\$ 199.46	\$ 275.05	\$ 16,706.43
2023	April	\$ 2,212.75	\$ 11,056.43	\$ 1,000.15	\$ 374.43	\$ 14,643.76
2023	May	\$ 1,043.77	\$ 12,075.52	\$ 1,343.01	\$ 317.39	\$ 14,779.69
2023	June	\$ 681.42	\$ 13,357.99	\$ 1,459.13	\$ 249.85	\$ 15,748.39
2023	July	\$ 969.11	\$ 12,710.30	\$ 1,569.31	\$ 247.43	\$ 15,496.15
2023	August	\$ 950.09	\$ 15,089.12	\$ 718.67	\$ 268.73	\$ 17,026.61
2023	September	\$ 1,558.42	\$ 14,996.79	\$ 1,654.62	\$ 406.28	\$ 18,616.11

2023	October	\$ 1,946.63	\$ 12,231.82	\$ 516.88	\$ 445.81	\$ 15,141.14
2023	November	\$ 3,534.57	\$ 10,269.11	\$ 160.55	\$ 354.47	\$ 14,318.70
2023	December	\$ 4,665.77	\$ 9,020.66	\$ 159.57	\$ 375.83	\$ 14,221.83
2023	TOTAL	\$ 34,451.75	\$ 137,023.02	\$ 9,104.53	\$ 4,019.21	\$ 184,598.51
2023	MO. AVERAGE	\$ 2,870.98	\$ 11,418.59	\$ 758.71	\$ 334.93	\$ 15,383.21
2022	January	\$ -	\$ 8,777.18	\$ 120.25	\$ 332.89	\$ 9,230.32
2022	February	\$ -	\$ 9,597.06	\$ 120.25	\$ 377.09	\$ 10,094.40
2022	March	\$ 1,215.93	\$ 8,917.77	\$ 120.25	\$ 377.05	\$ 10,631.00
2022	April	\$ 2,678.22	\$ 9,604.55	\$ 120.25	\$ 364.95	\$ 12,767.97
2022	May	\$ 1,711.88	\$ 11,861.38	\$ 120.25	\$ 566.94	\$ 14,260.45
2022	June	\$ 1,869.69	\$ 13,652.51	\$ 110.97	\$ 465.42	\$ 16,098.59
2022	July	\$ 1,419.76	\$ 13,750.49	\$ 392.56	\$ 201.52	\$ 15,764.33
2022	August	\$ 1,599.23	\$ 14,104.83	\$ 244.52	\$ 262.94	\$ 16,211.52
2022	September	\$ 1,074.73	\$ 15,148.59	\$ 120.25	\$ 389.79	\$ 16,733.36
2022	October	\$ 1,720.93	\$ 10,626.04	\$ 308.86	\$ 311.33	\$ 12,967.16
2022	November	\$ 4,174.33	\$ 11,008.94	\$ 161.28	\$ 353.94	\$ 15,698.49
2022	December	\$ 6,327.96	\$ 8,878.96	\$ 162.02	\$ 322.64	\$ 15,691.58
2022	TOTAL	\$ 23,792.66	\$ 135,928.30	\$ 2,101.71	\$ 4,326.50	\$ 166,149.17
2022	MO. AVERAGE	\$ 1,982.72	\$ 11,327.36	\$ 175.14	\$ 360.54	\$ 13,845.76
2021	January	\$ 3,957.78	\$ 8,355.79		\$ 621.06	\$ 12,934.63
2021	February	\$ 25,194.50	\$ 8,679.26		\$ 405.43	\$ 34,279.19
2021	March	\$ 2,092.81	\$ 7,457.02		\$ 407.77	\$ 9,957.60
2021	April	\$ 1,433.47	\$ 8,274.42		\$ 415.93	\$ 10,123.82
2021	May	\$ 1,047.04	\$ 9,846.53		\$ 857.23	\$ 11,750.80
2021	June	\$ 375.81	\$ 9,530.50		\$ 339.15	\$ 10,245.46
2021	July	\$ 1,363.76	\$ 11,219.27		\$ 319.51	\$ 12,902.54
2021	August	\$ 577.59	\$ 13,814.82		\$ 348.73	\$ 14,741.14
2021	September	\$ 821.77	\$ 14,365.94		\$ 397.04	\$ 15,584.75
2021	October	\$ -	\$ 10,565.97	\$ 96.74	\$ 455.17	\$ 11,117.88
2021	November	\$ -	\$ 10,555.75	\$ 120.25	\$ 360.66	\$ 11,036.66
2021	December	\$ -	\$ 8,460.84	\$ 120.25	\$ 349.46	\$ 8,930.55
2021	TOTAL	\$ 36,864.53	\$ 121,126.11	\$ 337.24	\$ 5,277.14	\$ 163,605.02
2021	MO. AVERAGE	\$ 3,072.04	\$ 10,093.84	\$ 28.10	\$ 439.76	\$ 13,633.75
2020	January	\$ 833.43	\$ 9,987.27	-	\$ 312.00	\$ 11,132.70
2020	February	\$ 3,380.48	\$ 11,939.74	-	\$ 364.00	\$ 15,684.22
2020	March	\$ 1,396.63	\$ 7,154.90	-	\$ 263.25	\$ 8,814.78
2020	April	\$ 2,528.20	\$ 8,214.10	-	\$ 196.75	\$ 10,939.05
2020	May	\$ 1,347.43	\$ 8,715.86	\$ 144.82	\$ 358.75	\$ 10,566.86
2020	June	\$ 533.13	\$ 9,227.51		\$ 750.75	\$ 10,511.39
2020	July	\$ 623.73	\$ 9,929.69		\$ 1,279.50	\$ 11,832.92
2020	August	\$ 609.93	\$ 9,703.04		\$ 299.25	\$ 10,612.22
2020	September	\$ 800.97	\$ 11,125.87	\$ 366.82	\$ 2,018.00	\$ 14,311.66

2020	October	\$ 1,277.77	\$ 8,776.44	\$ 272.62	\$ 676.50	\$ 11,003.33
2020	November	\$ 2,353.90	\$ 8,231.88	\$ -	\$ 342.00	\$ 10,927.78
2020	December	\$ 3,029.59	\$ 7,311.78		\$ 298.75	\$ 10,640.12
2020	TOTAL	\$ 18,715.19	\$ 110,318.08	\$ 784.26	\$ 7,159.50	\$ 136,977.03
2020	MO. AVERAGE	\$ 1,559.60	\$ 9,193.17	\$ 65.36	\$ 596.63	\$ 11,414.75
2019	January	\$ 10,774.68	\$ 8,288.12	-	\$ 202.16	\$ 19,264.96
2019	February	\$ 7,100.55	\$ 11,406.80	-	\$ 229.41	\$ 18,736.76
2019	March	\$ 4,610.15	\$ 9,973.56	-	\$ 217.63	\$ 14,801.34
2019	April	\$ 2,594.06	\$ 10,000.04	-	\$ 276.88	\$ 12,870.98
2019	May	\$ 1,432.03	\$ 10,607.20		\$ 264.38	\$ 12,303.61
2019	June	\$ 1,008.73	\$ 13,276.41	-	\$ 487.88	\$ 14,773.02
2019	July	\$ 725.14	\$ 15,042.24	-	\$ 187.88	\$ 15,955.26
2019	August	\$ 499.79	\$ 17,751.05	\$ 588.16	\$ 651.49	\$ 19,490.49
2019	September	\$ 1,624.23	\$ 16,535.04	-	\$ 573.63	\$ 18,732.90
2019	October	\$ 2,157.59	\$ 9,469.36	\$ 244.17	\$ 771.38	\$ 12,642.50
2019	November	\$ 2,741.68	\$ 9,540.09	-	\$ 371.38	\$ 12,653.15
2019	December	\$ 2,487.36	\$ 9,348.48	-	\$ 300.25	\$ 12,136.09
2019	TOTAL	\$ 37,755.99	\$ 141,238.39	\$ 832.33	\$ 4,534.35	\$ 184,361.06
2019	MO. AVERAGE	\$ 3,146.33	\$ 11,769.87	\$ 69.36	\$ 377.86	\$ 15,363.42
2018	January	\$ 5,001.75	\$ 7,451.47	-	\$ 209.53	\$ 12,662.75
2018	February	\$ 5,370.79	\$ 9,590.51	-	\$ 234.36	\$ 15,195.66
2018	March	\$ 2,174.37	\$ 7,499.34	-	\$ 198.94	\$ 9,872.65
2018	April	\$ 2,295.44	\$ 9,351.20	-	\$ 211.94	\$ 11,858.58
2018	May	\$ 910.46	\$ 10,241.04	-	\$ 188.88	\$ 11,340.38
2018	June	\$ 838.26	\$ 11,506.40	-	\$ 177.21	\$ 12,521.87
2018	July	\$ 959.19	\$ 14,680.50	-	\$ 169.66	\$ 15,809.35
2018	August	\$ 1,121.25	\$ 12,842.28	-	\$ 192.89	\$ 14,156.42
2018	September	\$ 1,699.76	\$ 15,711.84	-	\$ 264.92	\$ 17,676.52
2018	October	\$ 2,462.96	\$ 11,956.49	-	\$ 252.53	\$ 14,671.98
2018	November	\$ 888.13	\$ 8,969.72	-	\$ 259.53	\$ 10,117.38
2018	December	\$ 1,175.19	\$ 12,706.84	-	\$ 295.63	\$ 14,177.66
2018	TOTAL	\$ 24,897.55	\$ 132,507.63	\$ -	\$ 2,656.02	\$ 160,061.20
2018	MO. AVERAGE	\$ 2,074.80	\$ 11,042.30	\$ -	\$ 221.34	\$ 13,338.43
2017	January	\$ 6,707.40	\$ 9,908.46	-	\$ 234.14	\$ 16,850.00
2017	February	\$ 4,525.93	\$ 9,904.53	-	\$ 210.03	\$ 14,640.49
2017	March	\$ 3,142.99	\$ 10,122.67	-	\$ 205.31	\$ 13,470.97
2017	April	\$ 2,862.31	\$ 9,368.46	-	\$ 187.55	\$ 12,418.32
2017	May	\$ 741.31	\$ 11,624.57	-	\$ 176.70	\$ 12,542.58
2017	June	\$ 1,074.51	\$ 12,465.85	-	\$ 150.28	\$ 13,690.64
2017	July	\$ 152.23	\$ 9,950.98	-	\$ 163.09	\$ 10,266.30
2017	August	\$ 926.17	\$ 12,045.47	-	\$ 1,150.91	\$ 14,122.55
2017	September	\$ 1,069.01	\$ 11,049.87	\$ 226.16	\$ 501.08	\$ 12,846.12

2017	October	\$ 2,383.57	\$ 9,223.39	\$ 241.35	\$ 254.46	\$ 12,102.77
2017	November	\$ 2,602.53	\$ 7,444.70	-	\$ 180.14	\$ 10,227.37
2017	December	\$ 5,358.58	\$ 8,154.48	-	\$ 208.91	\$ 13,721.97
2017	TOTAL	\$ 31,546.54	\$ 121,263.43	\$ 467.51	\$ 3,622.60	\$ 156,900.08
2017	MO. AVERAGE	\$ 2,628.88	\$ 10,105.29	\$ 38.96	\$ 301.88	\$ 13,075.01
2016	January	6,073.86	\$ 7,528.70	-	\$ 245.18	13,847.74
2016	February	\$ 4,361.92	\$ 8,602.24	-	\$ 245.47	\$ 13,209.63
2016	March	\$ 3,431.00	\$ 9,956.54	-	\$ 233.91	\$ 13,621.45
2016	April	\$ 2,331.52	\$ 9,622.98	-	\$ 236.03	\$ 12,190.53
2016	May	\$ 1,498.91	\$ 9,151.30	-	\$ 227.75	\$ 10,877.96
2016	June	\$ 685.93	\$ 9,404.68	-	\$ 242.82	\$ 10,333.43
2016	July	\$ 658.87	\$ 10,336.45	-	\$ 253.44	\$ 11,248.76
2016	August	\$ 666.06	\$ 10,443.93	-	\$ 264.21	\$ 11,374.20
2016	September	\$ 921.35	\$ 13,303.86	\$ 215.56	\$ 232.24	\$ 14,673.01
2016	October	\$ 1,310.31	\$ 9,519.88	\$ 217.31	\$ 283.21	\$ 11,330.71
2016	November	\$ 3,018.06	\$ 10,613.91	-	\$ 266.81	\$ 13,898.78
2016	December	\$ 5,439.36	\$ 8,307.79	-	\$ 227.35	\$ 13,974.50
2016	TOTAL	\$ 30,397.15	\$ 116,792.26	\$ 432.87	\$ 2,958.42	\$ 150,580.70
2016	MO. AVERAGE	\$ 2,533.10	\$ 9,732.69	\$ 36.07	\$ 246.54	\$ 12,548.39
2015	January	\$ 4,135.29	\$ 10,177.91	-	\$ 239.39	\$ 14,552.59
2015	February	\$ 6,966.63	\$ 11,012.81	-	\$ 218.49	\$ 18,197.93
2015	March	\$ 2,171.86	\$ 9,556.07	-	\$ 209.09	\$ 11,937.02
2015	April	\$ 2,951.75	\$ 7,819.32	-	\$ 201.56	\$ 10,972.63
2015	May	\$ 1,205.32	\$ 9,811.46	-	\$ 173.42	\$ 11,190.20
2015	June	\$ 927.16	\$ 10,977.15	-	\$ 198.88	\$ 12,103.19
2015	July	\$ 729.41	\$ 12,372.63	-	\$ 152.73	\$ 13,254.77
2015	August	\$ 884.59	\$ 13,283.00	-	\$ 180.79	\$ 14,348.38
2015	September	\$ 831.27	\$ 12,844.73	-	\$ 211.80	\$ 13,887.80
2015	October	\$ 1,630.50	\$ 10,259.76	-	\$ 221.96	\$ 12,112.22
2015	November	\$ 3,406.64	\$ 9,530.58	-	\$ 219.15	\$ 13,156.37
2015	December	\$ 4,303.30	\$ 9,659.95	-	\$ 196.79	\$ 14,160.04
2015	TOTAL	\$ 30,143.72	\$ 127,305.37	\$ -	\$ 2,424.05	\$ 159,873.14
2015	MO. AVERAGE	\$ 2,511.98	\$ 10,608.78	\$ -	\$ 202.00	\$ 13,322.76

**PENDER PUBLIC SCHOOL
EXPENDITURE BUDGET REPORT
August 1, 2025**

		Annual Budget	YTD	Budget Balance	Percent Expended	Percent Remaining
01100	Regular Education	3,719,573.00	3,464,083.52	255,489.48	93.13%	6.87%
01200	School Age Special Education	1,242,103.00	1,131,577.43	110,525.57	91.10%	8.90%
01300	Summer School/Driver's Ed	8,756.00	100.00	8,656.00	1.14%	98.86%
02120/30	School Counselor/Nurse	137,394.00	118,987.45	18,406.55	86.60%	13.40%
02141-02190	ESU #1 SPED Services	196,151.00	166,660.00	29,491.00	84.97%	15.03%
02200	Staff Inservice/Library	156,237.00	150,069.42	6,167.58	96.05%	3.95%
02310	Board of Education	171,557.00	145,158.79	26,398.21	84.61%	15.39%
02320	Superintendent	203,295.00	199,876.91	3,418.09	98.32%	1.68%
02330	Legal Services	10,000.00	5,662.95	4,337.05	56.63%	43.37%
02400	Principals/Student Support	458,467.00	440,632.22	17,834.78	96.11%	3.89%
02500	Fiscal Services/Technology/Administrative	286,373.00	242,393.20	43,979.80	84.64%	15.36%
02600	Custodial/Maintenance/Equipment/Safety	843,818.00	726,811.09	117,006.91	86.13%	13.87%
02700	Regular & SPED Transportation	390,665.00	308,794.06	81,870.94	79.04%	20.96%
03400	Monsanto/College Access Grants	15,500.00	-	15,500.00	0.00%	100.00%
03535	High Ability Learner Grant	4,916.00	3,512.38	1,403.62	71.45%	28.55%
03551	Career & Technical Education	7,500.00	7,500.00	-	100.00%	0.00%
06200	Title I	79,525.00	81,131.90	(1,606.90)	102.02%	-2.02%
06310	Title II, Part A (NCLB Consolidated)	8,454.00	8,502.93	(48.93)	100.58%	-0.58%
06402	IDEA Part B (611) Transportation	400.00	-	400.00	0.00%	100.00%
06408	IDEA Part B (611) Base Allocation, Birth-Age 21	35,640.00	-	35,640.00	0.00%	100.00%
06410	IDEA Enrollment/Poverty (611)	73,029.00	82,678.68	(9,649.68)	113.21%	-13.21%
06925	Title III LEP Grant	1,493.00	-	1,493.00	0.00%	100.00%
06992	USDE REAP Grant	44,196.00	44,824.22	(628.22)	101.42%	-1.42%
08000	Transfer to Hot Lunch Fund/Activity	15,000.00	-	15,000.00	0.00%	100.00%
	<i>Unused Budget Authority</i>	333,048.00	-	333,048.00	0.00%	100.00%
TOTAL		8,443,090.00	7,328,957.15	1,114,132.85	86.80%	13.20%

Annual Budget Expenditure History

2023-24	Budget Totals	8,237,984.00	7,121,291.46	1,116,692.54	86.44%	13.56%
2022-23	Budget Totals	7,818,861.00	6,790,468.12	1,028,392.88	86.85%	13.15%
2021-22	Budget Totals	\$7,508,470.00	\$6,263,452.58	\$1,245,017.42	83.42%	16.58%
2020-21	Budget Totals	\$6,538,920.00	\$5,899,938.08	\$638,981.92	90.23%	9.77%
2019-20	Budget Totals	\$6,362,013.00	\$5,342,082.03	\$1,019,930.97	83.97%	16.03%
2018-19	Budget Totals	\$6,210,244.00	\$5,662,504.01	\$547,739.99	91.18%	8.82%
2017-18	Budget Totals	\$6,048,238.00	\$5,378,923.13	\$669,314.87	88.93%	11.07%
2016-17	Budget Totals	\$5,913,769.00	\$5,166,861.84	\$746,907.16	87.37%	12.63%
2015-16	Budget Totals	\$5,588,969.00	\$5,034,277.10	\$554,691.90	90.08%	9.92%
2014-15	Budget Totals	\$5,512,171.00	\$5,169,685.27	\$342,485.73	93.79%	6.21%
2013-14	Budget Totals	\$5,363,779.00	\$4,495,599.46	\$868,179.54	83.81%	16.19%
2012-13	Budget Totals	\$5,181,324.00	\$4,299,804.82	\$881,519.18	82.99%	17.01%
2011-12	Budget Totals	\$5,157,330.00	\$4,326,767.92	\$830,562.08	83.90%	16.10%
2010-11	Budget Totals	\$4,608,280.00	\$3,795,098.53	\$813,181.47	82.35%	17.65%
2009-10	Budget Totals	\$4,455,210.00	\$3,674,026.34	\$781,183.66	82.47%	17.53%
2008-09	Budget Totals	\$3,849,028.00	\$3,246,620.10	\$602,407.90	84.35%	15.65%
2007-08	Budget Totals	\$3,692,279.00	\$3,247,688.62	\$444,590.38	87.96%	12.04%
2006-07	Budget Totals	\$3,677,846.00	\$3,238,808.50	\$439,037.50	88.06%	11.94%

YTD Cash Balance

Sorted by Site, Group, Activity.
YTD through 07/31/2025.

Site ID	Site Name		Beginning Cash	Receipts	Disbursements	Adjustments	Cash Balance
Group ID	Group Name	Activity ID Activity Name					
PPS	Pender Public Schools						
A	ATHLETICS						
		1000 Operations	-\$ 3,157.50	\$ 40.00	\$ 4,388.36	\$ 0.00	-\$ 7,505.86
		110 BOYS BASKETBALL	\$ 2,047.77	\$ 5,696.10	\$ 5,719.34	-\$ 2,076.77	-\$ 52.24
		110-F Boys Basketball Fundraising	\$ 0.00	\$ 682.93	\$ 2,324.44	\$ 4,721.07	\$ 3,079.56
		115 BOYS GOLF	-\$ 6,195.23	\$ 1,120.00	\$ 1,873.01	-\$ 195.00	-\$ 7,143.24
		115-F Boys Golf Fundraising	\$ 0.00	\$ 30.00	\$ 0.00	\$ 195.00	\$ 225.00
		120 FOOTBALL	-\$ 53,709.72	\$ 7,910.99	\$ 18,009.70	-\$ 7,233.70	-\$ 71,042.13
		120-F Football Fundraising	\$ 0.00	\$ 9,250.06	\$ 10,165.98	\$ 7,187.77	\$ 6,271.85
		125 GIRLS BASKETBALL	\$ 4,216.03	\$ 6,407.73	\$ 8,686.15	\$ 0.00	\$ 1,937.61
		125-F Girls Basketball Fundraising	\$ 0.00	\$ 11,798.32	\$ 8,128.88	\$ 0.00	\$ 3,669.44
		130 GIRLS GOLF	-\$ 3,424.04	\$ 0.00	\$ 50.00	\$ 0.00	-\$ 3,474.04
		135 HS TRACK	-\$ 14,033.97	\$ 1,041.50	\$ 2,638.29	\$ 0.00	-\$ 15,630.76
		135-F HS Track & Field Fundraising	\$ 0.00	\$ 1,461.14	\$ 644.41	\$ 60.80	\$ 877.53
		140 JH BASKETBALL	-\$ 17,499.52	\$ 1,057.00	\$ 2,300.00	-\$ 150.00	-\$ 18,892.52
		145 JH FOOTBALL	-\$ 7,647.48	\$ 539.50	\$ 1,567.75	\$ 150.00	-\$ 8,525.73
		150 JH TRACK	-\$ 2,133.91	\$ 0.00	\$ 450.00	\$ 0.00	-\$ 2,583.91
		155 JH VOLLEYBALL	-\$ 827.04	\$ 837.00	\$ 860.00	\$ 0.00	-\$ 850.04
		160 JH WRESTLING	\$ 2,113.31	\$ 930.00	\$ 2,427.58	\$ 0.00	\$ 615.73
		165 VOLLEYBALL	\$ 2,238.45	\$ 2,599.82	\$ 5,999.11	-\$ 3,378.02	-\$ 4,538.86
		165-F Volleyball Fundraising	\$ 480.00	\$ 11,314.20	\$ 4,476.99	\$ 3,261.02	\$ 10,578.23
		170 HS WRESTLING	-\$ 2,684.83	\$ 5,385.15	\$ 7,166.47	-\$ 3,367.56	-\$ 7,833.71
		170-F HS Wrestling Fundraising	\$ 0.00	\$ 11,814.65	\$ 4,417.37	\$ 3,416.96	\$ 10,814.24
		172 Girls Wrestling	\$ 0.00	\$ 250.00	\$ 170.00	\$ 0.00	\$ 80.00
		175 WEIGHT LIFTING	-\$ 8,773.77	\$ 0.00	\$ 1,254.43	\$ 0.00	-\$ 10,028.20
		177 BOWLING	-\$ 1,865.00	\$ 0.00	\$ 1,589.35	\$ 0.00	-\$ 3,454.35
		177-F Bowling Fundraising	\$ 0.00	\$ 83.00	\$ 0.00	\$ 0.00	\$ 83.00
		182 BASEBALL	-\$ 10,674.94	\$ 0.00	\$ 500.00	\$ 0.00	-\$ 11,174.94
		185 CROSS COUNTRY	-\$ 7,081.23	\$ 2,524.95	\$ 2,784.10	\$ 0.00	-\$ 7,340.38
		185-F Cross County Fundraising	\$ 0.00	\$ 278.06	\$ 153.55	\$ 0.00	\$ 124.51
		195 EQUIPMENT	\$ 37,990.04	\$ 0.00	\$ 0.00	\$ 0.00	\$ 37,990.04
		197 ADVANCE TICKET SALES	\$ 51,912.00	\$ 1,465.00	\$ 0.00	\$ 0.00	\$ 53,377.00
		199 Unified Sports	\$ 1,080.55	\$ 0.00	\$ 0.00	\$ 0.00	\$ 1,080.55
		530-F Flames Fundraising	\$ 0.00	\$ 5,357.87	\$ 4,090.03	-\$ 895.18	\$ 372.66
		925-F Thunder Baseball Fundraising	\$ 0.00	\$ 1,658.50	\$ 2,967.18	\$ 7,579.81	\$ 6,271.13
		950 Thunder Girls Golf Coop	\$ 2,475.80	\$ 3,466.95	\$ 1,213.00	\$ 0.00	\$ 4,729.75
		950-F Thunder Girls Golf Coop Fundraising	\$ 0.00	\$ 460.28	\$ 200.00	-\$ 60.00	\$ 200.28
		985-F NEN Vipers Softball Coop - Fundraising	\$ 0.00	\$ 1,678.94	\$ 4,242.81	\$ 3,596.33	\$ 1,032.46
		A Totals:	-\$ 35,154.23	\$ 97,139.64	\$ 111,458.28	\$ 12,812.53	-\$ 36,660.34

YTD Cash Balance

Sorted by Site, Group, Activity.
YTD through 07/31/2025.

Site ID	Site Name	Beginning Cash	Receipts	Disbursements	Adjustments	Cash Balance
Group ID	Group Name					
	Activity ID Activity Name					
B	CLASSES					
	265 CLASS OF 2021	\$ 3,685.64	\$ 0.00	\$ 0.00	\$ 0.00	\$ 3,685.64
	270 CLASS OF 2022	\$ 37.55	\$ 0.00	\$ 0.00	\$ 0.00	\$ 37.55
	275 CLASS OF 2023	\$ 0.00	\$ 0.00	\$ 0.00	\$ 0.00	\$ 0.00
	280 CLASS OF 2024	\$ 178.86	\$ 0.00	\$ 0.00	\$ 0.00	\$ 178.86
	290 CLASS OF 2026	\$ 4,103.39	\$ 6,050.20	\$ 7,961.05	\$ 0.00	\$ 2,192.54
	291 CLASS OF 2027	\$ 0.00	\$ 4,613.45	\$ 676.32	\$ 7.60	\$ 3,944.73
	294 Class of 2025	\$ 1,861.14	\$ 0.00	\$ 1,840.09	\$ 0.00	\$ 21.05
	295 Class of 2017	\$ 0.00	\$ 0.00	\$ 0.00	\$ 0.00	\$ 0.00
	296 Class of 2018	\$ 0.00	\$ 0.00	\$ 0.00	\$ 0.00	\$ 0.00
	297 Class of 2019	\$ 0.00	\$ 0.00	\$ 0.00	\$ 0.00	\$ 0.00
	298 Class of 2020	\$ 0.00	\$ 0.00	\$ 0.00	\$ 0.00	\$ 0.00
	B Totals:	\$ 9,866.58	\$ 10,663.65	\$ 10,477.46	\$ 7.60	\$ 10,060.37
C	ACADEMIC CLUBS					
	315 INSTRUMENTAL	\$ 3,272.04	\$ 2,295.90	\$ 3,615.74	\$ 0.00	\$ 1,952.20
	315-F Instrumental Music Fundraising	\$ 0.00	\$ 17,981.55	\$ 5,899.74	\$ 0.00	\$ 12,081.81
	317 Jazz Band	-\$ 2,783.62	\$ 0.00	\$ 325.00	\$ 0.00	-\$ 3,108.62
	320 One-Act	\$ 556.09	\$ 0.00	\$ 543.68	\$ 0.00	\$ 12.41
	321 Speech	-\$ 5,850.36	\$ 383.30	\$ 1,150.58	-\$ 1,387.10	-\$ 8,004.74
	321-F Speech Fundraising	\$ 0.00	\$ 0.00	\$ 0.00	\$ 1,387.10	\$ 1,387.10
	322 QUIZ BOWL	\$ 1,097.36	\$ 0.00	\$ 40.00	\$ 0.00	\$ 1,057.36
	335 NATIONAL HONOR SOCIETY	\$ 2,836.14	\$ 417.80	\$ 585.40	\$ 0.00	\$ 2,668.54
	345 STUDENT COUNCIL	\$ 6,560.72	\$ 3,199.61	\$ 5,823.80	\$ 0.00	\$ 3,936.53
	350 VOCAL MUSIC	-\$ 9,229.98	\$ 11,126.40	\$ 11,517.48	\$ 0.00	-\$ 9,621.06
	350-F Vocal Fundraising	\$ 0.00	\$ 976.10	\$ 0.00	\$ 0.00	\$ 976.10
	360 BOOK FAIR PROCEEDS	-\$ 43.62	\$ 2,939.30	\$ 2,906.14	\$ 0.00	-\$ 10.46
	365 CLOSE-UP	\$ 1,274.73	\$ 15,519.90	\$ 14,440.22	\$ 0.00	\$ 2,354.41
	370 MUSICAL	\$ 7,037.63	\$ 2,945.62	\$ 2,102.90	\$ 0.00	\$ 7,880.35
	375 YEARBOOK	\$ 26,112.56	\$ 1,890.00	\$ 0.00	\$ 0.00	\$ 28,002.56
	C Totals:	\$ 30,839.69	\$ 59,675.48	\$ 48,950.68	\$ 0.00	\$ 41,564.49

YTD Cash Balance

Sorted by Site, Group, Activity.
YTD through 07/31/2025.

Site ID	Site Name					
Group ID	Group Name					
Activity ID	Activity Name	Beginning Cash	Receipts	Disbursements	Adjustments	Cash Balance
E	MISCELLANEOUS					
410	STRIV	-\$ 1,056.02	\$ 0.00	\$ 0.00	\$ 0.00	-\$ 1,056.02
420	Elementary Box Top Money	\$ 1,505.71	\$ 9.50	\$ 0.00	\$ 0.00	\$ 1,515.21
430	Heese Event Center Contributions	\$ 477.00	\$ 0.00	\$ 0.00	\$ 0.00	\$ 477.00
435	SPED Fundraising	\$ 5,126.23	\$ 0.00	\$ 300.32	\$ 0.00	\$ 4,825.91
440	CHEERLEADING	-\$ 372.81	\$ 0.00	\$ 0.00	\$ 0.00	-\$ 372.81
445	MISCELLANEOUS	-\$ 47.15	\$ 1,290.00	\$ 3,150.55	-\$ 2,644.30	-\$ 4,552.00
450	F&R Sponsor Pd by District	-\$ 22.40	\$ 0.00	\$ 11,128.64	\$ 0.00	-\$ 11,151.04
455	Care Closet	\$ 2,811.25	\$ 463.81	\$ 978.73	\$ 0.00	\$ 2,296.33
500	DONATION	\$ 25,153.30	\$ 0.00	\$ 0.00	\$ 0.00	\$ 25,153.30
501	Staff Conc Proceeds	\$ 1,071.79	\$ 593.10	\$ 129.62	\$ 0.00	\$ 1,535.27
503	Climate Committee	\$ 0.00	\$ 910.24	\$ 263.49	\$ 0.00	\$ 646.75
505	Pender Booster Club	-\$ 383.76	\$ 229.50	\$ 249.95	\$ 0.00	-\$ 404.21
509	Scholarships	\$ 0.00	\$ 2,450.00	\$ 2,300.00	\$ 0.00	\$ 150.00
510	CONCESSIONS	\$ 43,920.57	\$ 34,439.33	\$ 27,926.37	\$ 299.53	\$ 50,733.06
525	INTEREST	-\$ 81,656.54	\$ 664.39	\$ 0.00	\$ 0.00	-\$ 80,992.15
530	FLAMES	-\$ 4,903.45	\$ 50.00	\$ 1,234.79	\$ 1,012.18	-\$ 5,076.06
535	PENDER POP MACHINE	\$ 31,578.37	\$ 11,507.05	\$ 20,981.65	-\$ 130.00	\$ 21,973.77
540	PICTURE MONEY	\$ 4,287.18	\$ 0.00	\$ 0.00	\$ 0.00	\$ 4,287.18
580	CM Science Day	\$ 433.28	\$ 300.00	\$ 131.05	\$ 0.00	\$ 602.23
585	ART CLUB	\$ 932.34	\$ 277.15	\$ 387.97	\$ 0.00	\$ 821.52
620	ACTIVITY FEES	\$ 4,500.00	\$ 19.77	\$ 0.00	\$ 0.00	\$ 4,519.77
777	E-Sports	\$ 67.47	\$ 1,131.22	\$ 3,236.26	-\$ 1,175.64	-\$ 3,213.21
777-F	e-Sports Fundraising	\$ 0.00	\$ 4,174.29	\$ 3,017.84	\$ 1,198.44	\$ 2,354.89
	E Totals:	\$ 33,422.36	\$ 58,509.35	\$ 75,417.23	-\$ 1,439.79	\$ 15,074.69
F	VOCATIONAL					
606	FFA LEADERSHIP	\$ 39,298.95	\$ 3,217.69	\$ 3,077.79	\$ 0.00	\$ 39,438.85
610	FFA	\$ 67,573.96	\$ 82,539.64	\$ 77,801.98	\$ 0.00	\$ 72,311.62
615	FFA INSTRUCTOR	-\$ 11,017.41	\$ 0.00	\$ 160.55	\$ 0.00	-\$ 11,177.96
	F Totals:	\$ 95,855.50	\$ 85,757.33	\$ 81,040.32	\$ 0.00	\$ 100,572.51
G	ADMINISTRATION					
700	HOSTED CONTEST	\$ 40,076.34	\$ 20,151.01	\$ 20,192.86	-\$ 456.00	\$ 39,578.49
705	STAFF DEVELOPMENT	-\$ 4,131.74	\$ 0.00	\$ 0.00	\$ 0.00	-\$ 4,131.74
710	STATE CONTEST	-\$ 28,845.36	\$ 1,539.00	\$ 17,268.86	\$ 0.00	-\$ 44,575.22
715	EQUIPMENT	-\$ 21,108.74	\$ 0.00	\$ 0.00	\$ 0.00	-\$ 21,108.74
720	MISCELLANEOUS	-\$ 20,579.04	\$ 0.00	\$ 0.00	\$ 0.00	-\$ 20,579.04
	G Totals:	-\$ 34,588.54	\$ 21,690.01	\$ 37,461.72	-\$ 456.00	-\$ 50,816.25
H	INVESTMENTS					
1010	CERTIFICATES OF DEPOSIT	\$ 52,894.69	\$ 0.00	\$ 0.00	\$ 0.00	\$ 52,894.69
1020	INTEREST ON CD'S	\$ 28,939.56	\$ 0.00	\$ 0.00	\$ 2,481.50	\$ 31,421.06
	H Totals:	\$ 81,834.25	\$ 0.00	\$ 0.00	\$ 2,481.50	\$ 84,315.75

YTD Cash Balance

Sorted by Site, Group, Activity.
YTD through 07/31/2025.

Site ID	Site Name					
Group ID	Group Name					
Activity ID	Activity Name	Beginning Cash	Receipts	Disbursements	Adjustments	Cash Balance
I CO-OP ACTIVITIES						
2005	Raptor JH VB	-\$ 903.18	\$ 0.00	\$ 0.00	\$ 0.00	-\$ 903.18
2010	Raptor JH Football	-\$ 4,166.49	\$ 0.00	\$ 0.00	\$ 0.00	-\$ 4,166.49
2015	Raptors JH Girls Basketball	\$ 174.32	\$ 0.00	\$ 0.00	\$ 0.00	\$ 174.32
2020	Raptors JH Boys Basketball	-\$ 528.42	\$ 0.00	\$ 0.00	\$ 0.00	-\$ 528.42
2025	Raptors JH Wrestling	-\$ 3,168.58	\$ 0.00	\$ 0.00	\$ 0.00	-\$ 3,168.58
2030	Raptors JH Track	-\$ 2,342.03	\$ 0.00	\$ 0.00	\$ 0.00	-\$ 2,342.03
905	Raptor HS Track	-\$ 6,038.52	\$ 0.00	\$ 0.00	\$ 0.00	-\$ 6,038.52
915	TC Thunder Bowling	-\$ 486.00	\$ 0.00	\$ 0.00	\$ 0.00	-\$ 486.00
925	Thunder Baseball	\$ 1,471.40	\$ 16,181.23	\$ 7,564.16	-\$ 7,579.81	\$ 2,508.66
975	Raptor Speech	-\$ 120.00	\$ 0.00	\$ 0.00	\$ 0.00	-\$ 120.00
985	NEN Vipers Softball Co-op	-\$ 6,500.27	\$ 6,936.40	\$ 14,634.69	-\$ 3,494.53	-\$ 17,693.09
I Totals:		-\$ 22,607.77	\$ 23,117.63	\$ 22,198.85	-\$ 11,074.34	-\$ 32,763.33
PPS Totals:		\$ 159,467.84	\$ 356,553.09	\$ 387,004.54	\$ 2,331.50	\$ 131,347.89
Report Totals:		\$ 159,467.84	\$ 356,553.09	\$ 387,004.54	\$ 2,331.50	\$ 131,347.89

Receipt History

Detail report. Sorted by Site, Receipt Number.
From 07/01/2025 to 07/31/2025.

Receipt Number	Receipt Date	Void Date	Deposit Number	Check Number	Received From	Amount	Sales Tax	Amount
Activity ID	Activity Name		Fee Name & Student ID			Tax Amount		
Tax Name	Tax Activity			Tax Rate %				
PPS Pender Public Schools								
004051	07/01/2025		07-01-2025		cash			VB golf tourney hole sponsor
165-F	Volleyball Fundraising					100.00	0.00	100.00
						Total For 004051:		100.00
004052	07/01/2025		07-01-2025		NSAA			24-25 Dist Host fees & Track WR
700	HOSTED CONTEST					700.00	0.00	700.00
170	HS WRESTLING					50.00	0.00	50.00
172	Girls Wrestling					125.00	0.00	125.00
						Total For 004052:		875.00
004053	07/01/2025		07-01-2025		NSAA			NSAA State Contest
985	NEN Vipers Softball Co-op					1,878.60	0.00	1,878.60
185	CROSS COUNTRY					358.95	0.00	358.95
120	FOOTBALL					80.75	0.00	80.75
170	HS WRESTLING					400.75	0.00	400.75
125	GIRLS BASKETBALL					3,240.10	0.00	3,240.10
135	HS TRACK					1,041.50	0.00	1,041.50
						Total For 004053:		7,000.65
004054	07/14/2025		7-14-2025		Nat'l FFA Assoc (Kaser			scholarship reimbursement
606	FFA LEADERSHIP					750.00	0.00	750.00
						Total For 004054:		750.00
004055	07/14/2025		7-14-2025		Kinning			dance camp reg fees
530-F	Flames Fundraising					394.00	0.00	394.00
						Total For 004055:		394.00
004056	07/14/2025		7-14-2025		Pender Betterment Group			donation from Alumni weekend
365	CLOSE-UP					1,000.00	0.00	1,000.00
						Total For 004056:		1,000.00
004057	07/16/2025		7-16-2025		Hansen and Kent			salt sales
120-F	Football Fundraising					300.00	0.00	300.00
						Total For 004057:		300.00
004058	07/15/2025		7-15-2025		Holloway			cash to cover NSF check
170-F	HS Wrestling Fundraising					150.00	0.00	150.00
						Total For 004058:		150.00
004059	07/17/2025		07-17-2025		dancers			dance tshirts
530-F	Flames Fundraising					28.00	0.00	28.00
						Total For 004059:		28.00
004060	07/17/2025		07-17-2025		Felber			Flames camp reg fee
530-F	Flames Fundraising					167.49	0.00	167.49
						Total For 004060:		167.49
004061	07/17/2025		07-17-2025		Gralheer			state golf tshirt sales
115-F	Boys Golf Fundraising					30.00	0.00	30.00
						Total For 004061:		30.00
004062	07/21/2025		7-21-25		Trimble			dance t-shirt & dance camp reg
530-F	Flames Fundraising					211.00	0.00	211.00

Receipt History

Detail report. Sorted by Site, Receipt Number.
From 07/01/2025 to 07/31/2025.

Receipt Number	Receipt Date	Void Date	Deposit Number	Check Number	Received From	Receipt Description	Amount	Sales Tax	Amount
Activity ID	Activity Name		Fee Name & Student ID				Amount	Tax Amount	Amount
Tax Name	Tax Activity						Tax Amount		
							Total For 004062:		211.00
004063	07/28/2025		7-28-2025		Svacek and Walsh	gbb rings			
125-F	Girls Basketball Fundraising						428.00	0.00	428.00
							Total For 004063:		428.00
004064	07/28/2025		7-28-2025		dancers	flames tshirts & camp reg fees			
530-F	Flames Fundraising						422.18	0.00	422.18
							Total For 004064:		422.18
004065	07/28/2025		7-28-2025		Mosser	donation			
291	CLASS OF 2027						50.00	0.00	50.00
							Total For 004065:		50.00
004066	07/30/2025		7-30-2025		community members	sweetcorn sales			
120-F	Football Fundraising						924.01	0.00	924.01
							Total For 004066:		924.01
004067	07/30/2025		7-30-2025		dancers	flames tshirt reimbursement			
530-F	Flames Fundraising						28.00	0.00	28.00
							Total For 004067:		28.00
004068	07/30/2025		7-30-2025		parents	Watermelon Days dance camp			
530-F	Flames Fundraising						480.00	0.00	480.00
							Total For 004068:		480.00
004069	07/31/2025		7-31-2025		Edutrak	Activity Passes / Edutrak			
197	ADVANCE TICKET SALES						150.00	0.00	150.00
							Total For 004069:		150.00
004070	07/31/2025		7-31-2025		Frontier Bank	interest earned			
525	INTEREST						35.01	0.00	35.01
							Total For 004070:		35.01
							Site Total		13,523.34
							Report Total		13,523.34

Pender Public Schools

Superintendent's Report

August 18, 2025

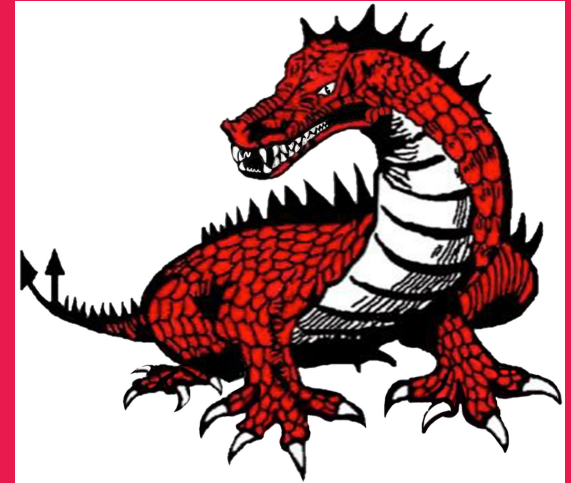

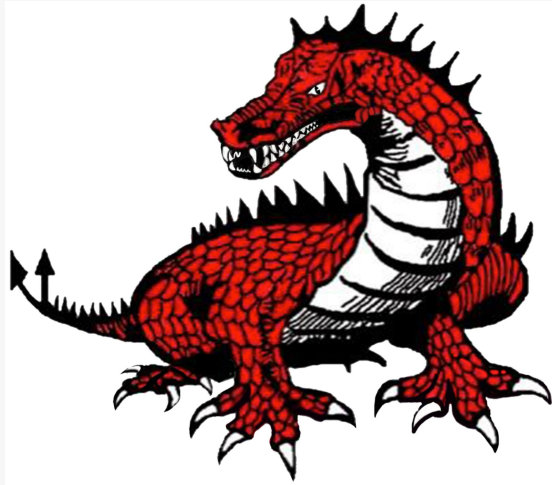

Mission Statement

The mission of the Pender Public School District is to provide quality educational opportunities in a safe, positive learning environment that motivates and challenges all students to become productive and responsible citizens

Superintendent Goals

#1

Lead the District through the goal setting phase of the school improvement process

#2

Visit every classroom 1 time per month

#3

Conduct a physical walk through of the building 1 time per month

#4

Be in the moment

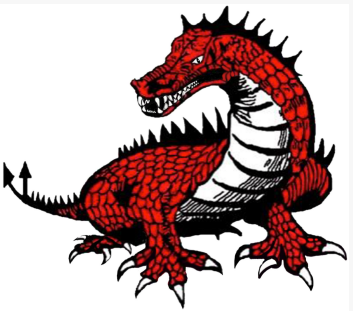

Conferences and Workshops

- July 18-21 - Out of Office
- July 31 - Pender PD Planning Meeting with ESU 1
- August 11 - Staff Reports for the 25-26 School Year
- August 11 - Start of Fall Sports
- August 12 - School Finance Review Commission Meeting
- August 14 - First Day of the 25-26 School Year (K-12)
- August 15 - Board President Meeting
- August 18 - First Day of the 25-26 School Year (Preschool)
- August 18 - Facilities / Transportation Committee Meeting
- August 18 - Board of Education Meeting
- August 20 - EHC Kickoff Meetings
- August 21 - Competitions Start for GG & SB
- August 27 - ESU 1 Superintendents Meeting
- August 27 - NASB Area Membership Meeting
- August 28 - Competitions Start for FB, VB, & XC
- August 28 - Rule 3 (HAL) Webinar
- September 8 - PED / PCD Meeting
- September 8 - Board of Education Meeting
- September 15 - P2T Board Meeting

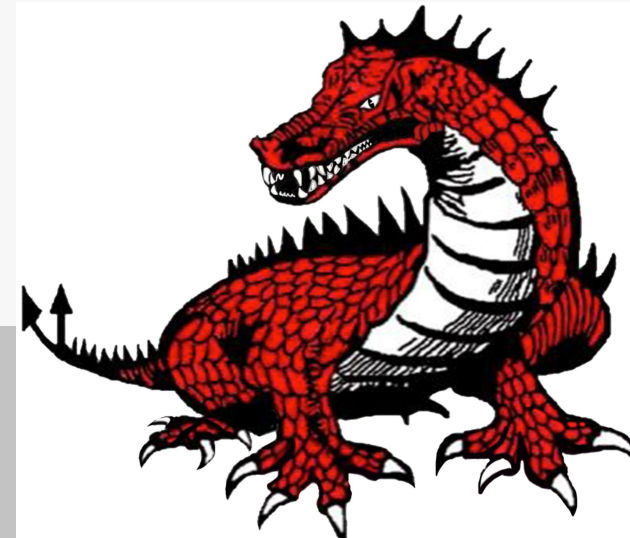

School Improvement

- July 15 - August 10 - Planning for 25-26
- August 11-14 - Preservice
- August 20
 - Elementary - Staff Meeting
 - Secondary - Staff Meeting
- August 27
 - Elementary - Work Time
 - Secondary - Work Time
- September 3
 - Elementary - NSCAS Update
 - Secondary - NSCAS Update

Income Eligibility Guidelines School Nutrition Program

Household size	Yearly	Monthly	Twice per Month	Every Two Weeks	Weekly
1	28,953	2,413	1,207	1,114	557
2	39,128	3,261	1,631	1,505	753
3	49,303	4,109	2,055	1,897	949
4	59,478	4,957	2,479	2,288	1,144
5	69,653	5,805	2,903	2,679	1,340
6	79,828	6,653	3,327	3,071	1,536
7	90,003	7,501	3,751	3,462	1,731
8	100,178	8,349	4,175	3,853	1,927
Each additional person:	10,175	848	424	392	196

School Nutrition Program Personnel

- Jaclyn Anderson was moved from a paraprofessional position to the kitchen staff
- When the position opened, she expressed interest
- She has quite a bit of experience in food service, so she adds value and fits well

Changes with Activity Administration

- Secondary Principal - all human resource tasks
- Activities Director - event coordinator (scheduling, workers, open, close, etc.)
- Changes to the Coaches Manual and Extra Curricular Activities Handbook to reflect the above responsibilities
- Examples
 - Parent concern about something a coach is going - AD is not part of the process
 - Student discipline issue involving alcohol - AD is not part of the process
 - Hiring or firing of a coach - AD is not part of the process

End of Fiscal Year

- This meeting will function as our end of fiscal year meeting
- All budgets were reviewed on August 8, 2025 for end of fiscal year purposes, and all budgets were in good shape
- No budget amendments will be needed

School Classification

- LB1329 (2024) revised 79-102
- All districts are classified based on the following:
 - Class 1: Under 1,500 inhabitants
 - Class 2: 1,500 - 4,999 inhabitants
 - Class 3: 5,000 - 199,999 inhabitants
 - Class 4: 200,000 or more inhabitants & city of the primary class
 - Class 5: City of the metropolitan class
- Pender Public Schools is a Class 2 district
- <https://www.education.ne.gov/wp-content/uploads/2024/12/SchoolDistrictClassifications.pdf>
- Changes on January 1 of every year based on census information

Budget Timeline

- September 4 - deadline to notify and submit information to County Assessor if Joint Public Hearing is required
- September 14-28 - Joint Public Hearing scheduled during this time frame (must occur after 6:00 pm)
- September 30 - budget due to NDE, Auditor of Public Accounts, and County Clerk

2025-2026 Budget Information

LB 644 Information

- School districts in Nebraska are allowed to increase their tax asking by 2% plus real growth without the need for a public hearing
 - 2023 - \$5,417,106.77 (levy of \$0.813283)
 - 2024 - \$5,629,203.46 (levy of \$0.770534)
 - 2025 - \$5,732,072.58 (levy of \$0.xxx)
- If the threshold is exceeded, a tax request hearing is required
- Districts must inform the county assessor by September 4 if a hearing is required or not
- By the August 26 Special Board Meeting, I will know whether or not we will need to participate

LB 243 Information

- School District Property Tax Limitation Act
- Applies to only the General Fund and Special Building Fund
- Districts are limited to 3% revenue growth
- Local school boards can vote to exceed that amount by a percentage based on enrollment
 - Pender can exceed the growth limit by 7%
 - PPS BOE approved this in June
- Essentially creates a new levy limit specific to each school district (the \$1.05 levy limit doesn't really exist for practical purposes)
 - \$5,790,351 - without 7% increase (\$0.xxx levy limit)
 - \$6,352,623 with 7% increase (\$0.xxx levy limit)

Budget Plan

- Utilize the August 26 Special Board Meeting as a work session to discuss the 24-25 budget
- Deanna and I plan to dig in tomorrow ... we still do not have valuation from one of our 3 counties
- After the August 26 Special Board Meeting, a budget can be prepared to meet all legal deadlines
- All budget related action required by the Board can then be taken during the September 8 Board of Education Meeting

Summer Food Service

- The summer food service was a success in the summer of 2025
- 21,316 meals were served (breakfast & lunch)
- \$90,486.42 (about \$4.25 per meal)
 - Breakfast reimbursement was \$3.0875
 - Lunch reimbursement was \$5.4025
- Expenses are being calculated, but they will not exceed \$90,000 (in fact, they will be well under that amount)
- Our school year revenue in 24-25 was \$126,957.91

Elementary Building AC

- The air conditioning unit that serves the elementary building, new gym, and a couple of other areas went down at the end of the first day of school
- There are 2 compressors, and both were struggling
 - Both have 2 circuits (4 total)
 - Only 1 of the 4 circuits was functioning
- Rasmussen came on the 2nd day of school, and they were able to get 1 of the 2 compressors back to full strength
- Over the weekend, the building cooled down, so we are in good shape (for now)
- A repair of the 2nd compressor is critical
- A quote for \$13,976 from Rasmussen to fix it was received
- This compressor has had chronic issues; it may be worth it for the District to look at completely redoing the air conditioning infrastructure that serves this portion of the building

Under Armour

- Our agreement with Under Armour has started
- All of these items are part of our signing bonus
- We get a couple of other benefits as well
- This agreement will be analyzed over time to determine if is beneficial (I'm optimistic)



UNDER ARMOUR

1- 10' x 3' PROvinyl Banner
1- 18" x 18" PVC Sign *matrix
1 - Sign Day Pkg (10' media / 6' cover)
1- 10' x 10' Canopy tent
50- 3" x 3" Decals *matrix

RETAIL: \$3500⁰⁰

UA Team Banner 10'w x 3't



Media Signing Day Kit

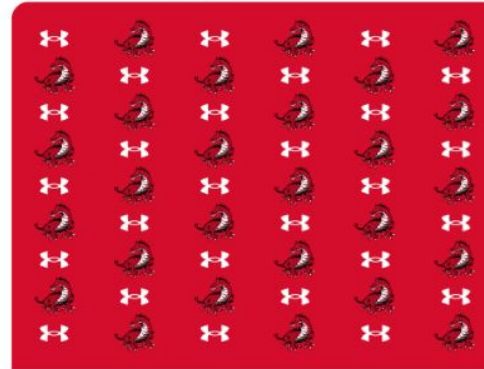

PMS
186 C

PMS
VIC
BLACK

PMS
VIC
WHITE

PVC 18" x 18"



Decals 3" x 4.5"



10' Tent Kit



Summer Projects Update

- Preschool roof - will be completed by August 4
- Elementary restrooms - in progress; should be done in time
- Art room flooring - done
- Backboard inspections in new gym - done
- LED light tube upgrade in new gym - not done
- 3rd floor water fountain - not done
- Window coverings in room 304 - done
- Shades for turf area - will be installed prior to August 11

Board of Education Recognition

- Mandy Johnson - Level IV
- Recognized at NASB Area Membership Meeting later this month

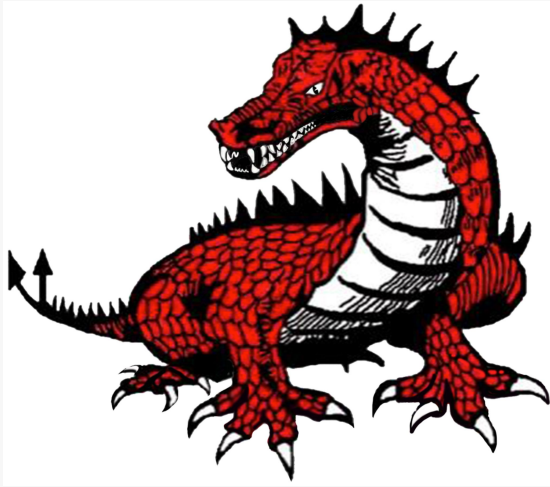

September Board of Education Meeting

- Budgets of expenditure hearing and subsequent adoption
- System wide tax request resolution hearing and subsequent adoption
 - OR - Joint public hearing due to exceeding the levy threshold

**It's a GREAT Day to be a
Pendragon!!!**

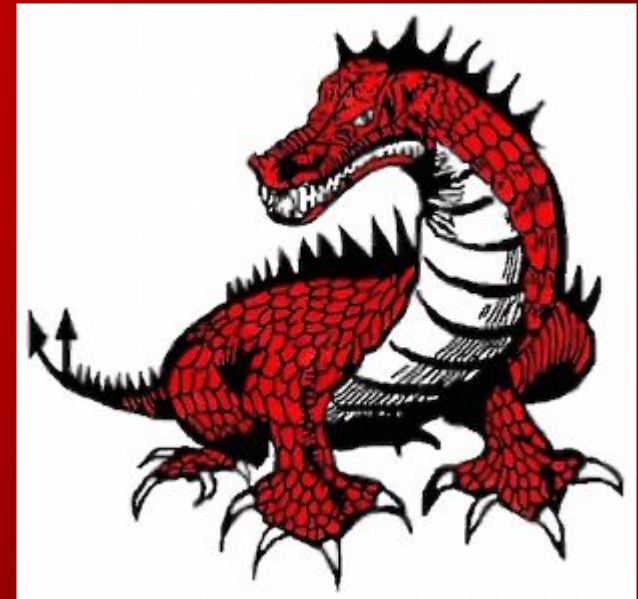

The background is a vibrant, abstract pattern of wavy, organic shapes in shades of orange, red, green, and blue. A white rectangular area in the center contains the title and date. Various school-related icons are scattered around the white area: a stack of books in the top left, an alarm clock in the top right, a blue notebook in the bottom left, and a white paper airplane in the bottom right.

Elementary Principal's Report

August 18, 2025



Mission Statement



The mission of the
Pender Public School District
is to provide quality educational opportunities
in a safe, positive learning environment
that motivates and challenges all students
to become productive and responsible
citizens.

Professional Impact Areas

01

Climate & Culture

Work to consistently create a positive environment for our students and staff. Continue to build a culture of excellence.

02

Purposeful Engagement

Create opportunities for our entire K-12 staff to work, learn, and play together.

03

Champion Our People

Be present. Take one more lap to see ALL the great things that are impacting who we are as a district. Recognize and celebrate our people!

04

Go Higher!

Encourage and challenge our students and staff. Acknowledge how far they have come and propel them to chase bigger ambitions!

Be A Champion

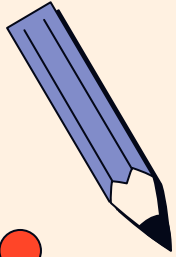

Workshops, Meetings & Events



Previous Events

- * Planning with ESU#1 (Kellen)
- * Planning with Admin Team
- * Open House
- * Pre-Service with Staff



Upcoming Events

- * ESU #1 Principals Meeting



LB 399



- ★ Dr. Martin Luther King, Jr.'s birthday (January 15, 1929)
 - ★ Abraham Lincoln's birthday (February 12, 1809)
 - ★ George Washington's birthday (February 22, 1732)
 - ★ Memorial Day (May - the last Monday in May)
 - ★ Constitution Day (September 17 - every year)
 - ★ Veterans Day (November 11 - every year)
 - ★ Thanksgiving Day (November - 4th Thursday in November)
 - ★ Native American Heritage Day (November - The Friday after Thanksgiving)
- 
- 



25-26 School Year

Class Sizes

4Y0 Preschool -	29
Kindergarten -	31
1st Grade -	33
2nd Grade -	29
3rd Grade -	30
4th Grade -	24
5th Grade -	24
6th Grade -	40

Adopt the Breeze

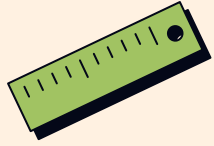
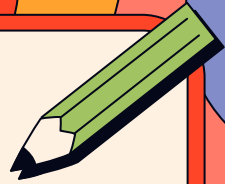

First and Third
Wednesday of
the month @
10:00 a.m.

September - 4Y0 Preschool

October - 3rd Grade

November - 4th Grade

December - 5th Grade

January - 1st Grade

February - 2nd Grade

March - 6th Grade

April - Kindergarten

May - Final Celebration

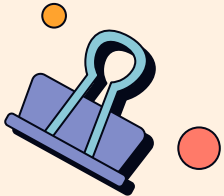

FALL BENCHMARKING



K-6 TESTING

- MAP Growth
- Aimsweb Plus
- Guided Reading Benchmarking

The logo for MAP Growth, featuring the word "map" in a bold, green, lowercase font with a registered trademark symbol, and the word "GROWTH" in a smaller, black, uppercase font below it.

map[®]
GROWTH™

The logo for aimsweb PLUS, featuring the word "aimsweb" in a black, lowercase font with a registered trademark symbol, and the word "PLUS" in a smaller, black, uppercase font below it. To the right of "PLUS" is a stylized cross icon with a yellow vertical bar and a blue horizontal bar.

aimsweb[®]
PLUS

The C5Q Great Reading Race

- Big thanks to Tony and Lisa Crippen for once again sponsoring the Great Reading Race!
- C5Q Great Reading Race took the place of Welsh's BOB last year.
- Students get Chicken Strips & Fries with the purchase of an adult meal if they meet their classroom reading goal.
- Each grade level sets a reading goal appropriate for their students.

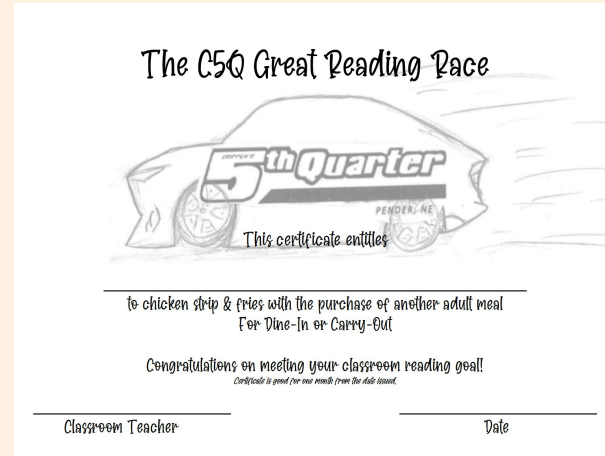

TeachTown

- Program designed to meeting the curricular needs of our most significantly disabled students.
- Often a tough population for teachers to address because our regular education curriculums just don't fit.
- Came recommended by LCC who has operated a Level 3 program for many years.
- \$4150 per year for software
 - 3 Year software agreement
- \$3650 one time cost for K-2 physical goods (manipulatives, books, teachers guides)
- \$1498 one time cost for Transition to Adulthood Support Kit
- \$1500 for training
- \$11, 104. 76 year 1 total
 - \$4150 year 2 & 3
 - Total - \$19,404.76
- SPED expenditure at a reimbursable rate over 80%

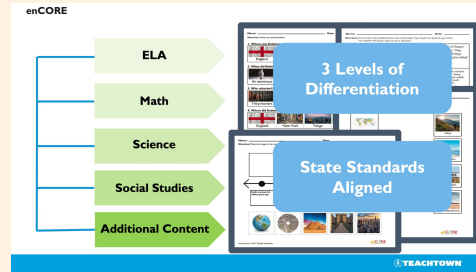

enCORE

Drive measurable student outcomes with enCORE, a K-12+, standards-first adapted core curriculum for students with moderate to severe disabilities.

Thank You For Championing PPS!



Power of Positive Leadership

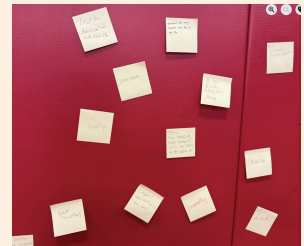
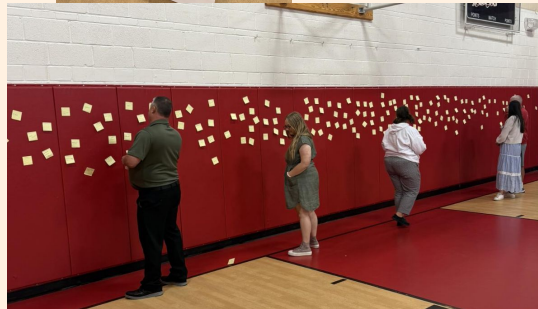
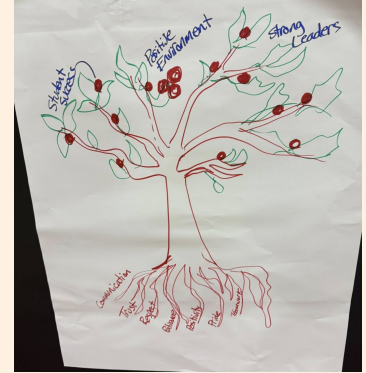
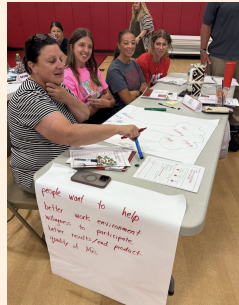
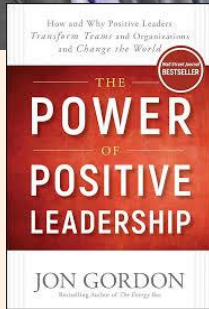

Preservice Time



Welcome
Back

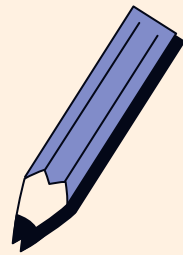
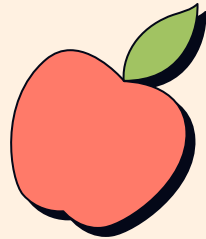

Pride Awards



PREPERATION - RESPECT - INTEGRITY - DETERMINATION - EXCELLENCE



Upcoming Events

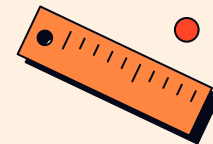

Mon. Aug. 18 - BOE Meeting 8:00 p.m.

Wed. Aug. 20 - 2:30 Dismissal - Work Time

Mon. Aug. 25 - School Pictures

Tues. Aug. 26 - ESU #1 Principals Meeting

Wed. Aug. 27 - 2:30 Dismissal - Work Time

Mon. Sept. 1 - No School

Tues. Sept. 2- Homecoming Week!!

Wed. Sept. 3 - 2:30 Dismissal - NSCAS Update

Wed. Sept. 10- Farm Safety Day

Wed. Sept. 10 - 2:30 Dismissal - MTSS

Mon. Sept. 15 - BOE Meeting 7:00 p.m.

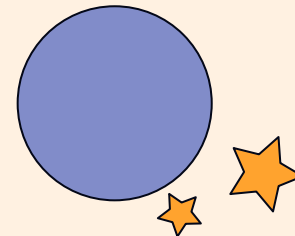
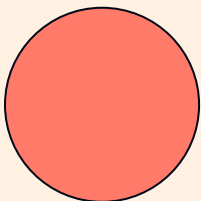

August Secondary Principals Report

Pender Public Schools
8/18/25

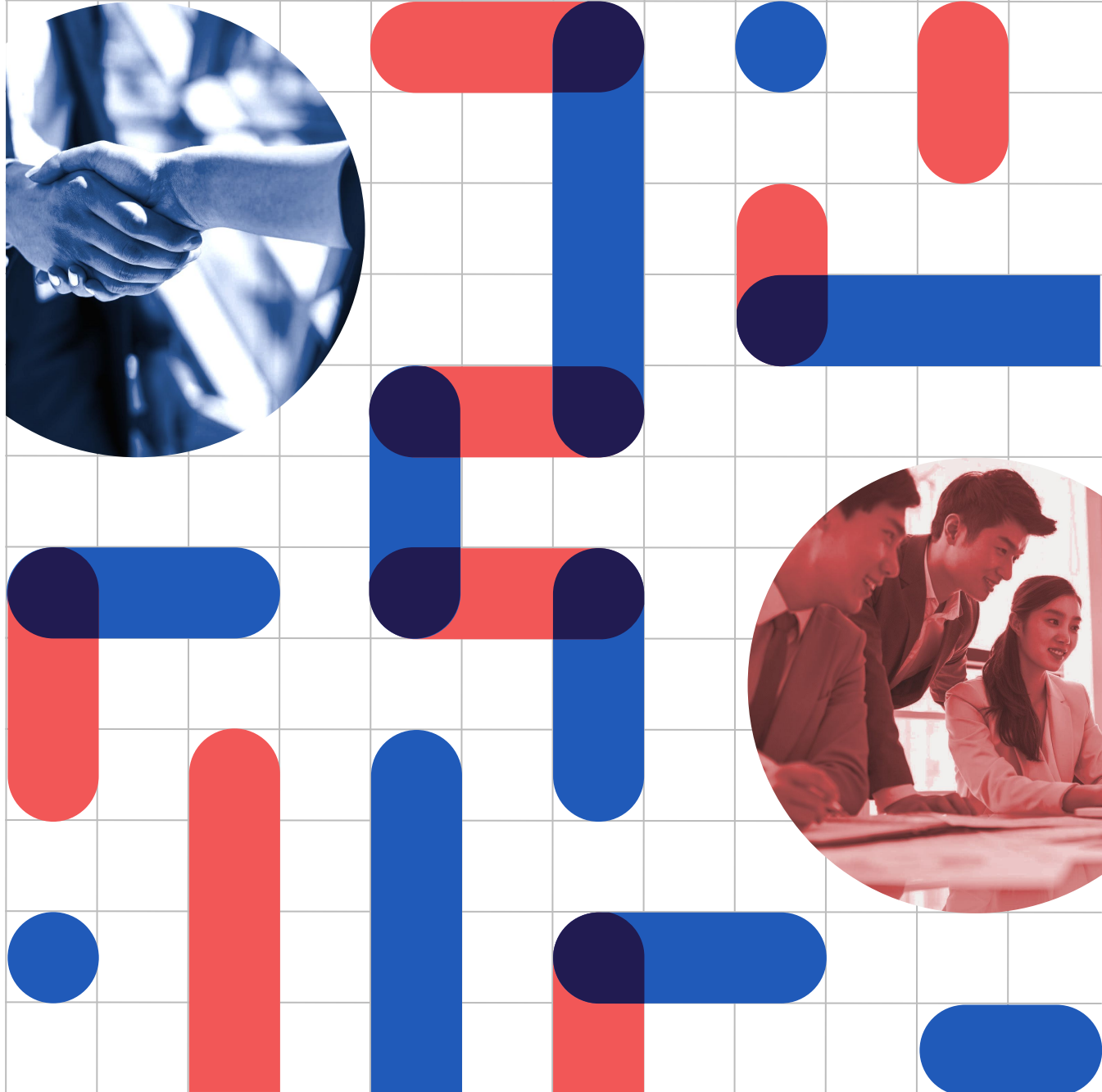

A decorative background on the left side of the slide featuring a light gray grid. Various blue and red shapes, including circles, rounded rectangles, and overlapping bars, are scattered across the grid. The text 'Be a Champion' is overlaid on this grid.

**Be a
Champion**

Mission Statement

The mission of the Pender Public School District is to provide quality educational opportunities in a safe, positive learning environment that motivates and challenges all students to become productive and responsible citizens.

LB 399

- a. Dr. Martin Luther King, Jr.'s birthday (January 15, 1929)
- b. Abraham Lincoln's birthday (February 12, 1809)
- c. George Washington's birthday (February 22, 1732)
- d. Memorial Day (May - the last Monday in May)
- e. Constitution Day (September 17 - every year)
- f. Veterans Day (November 11 - every year)
- g. Thanksgiving Day (November - 4th Thursday in November)
- h. Native American Heritage Day (November - the Friday after Thanksgiving)

Conferences/Workshops/Meetings

Past Events

- Planning with Admin Team
- Planning with ESU1
- New Teacher Orientation
- Staff Preservice
- Open House
- Second Day Drills

Upcoming Events

- MAPS/NSCAS Testing
- ESU1 Principal's Meeting
- SAT Team Meeting

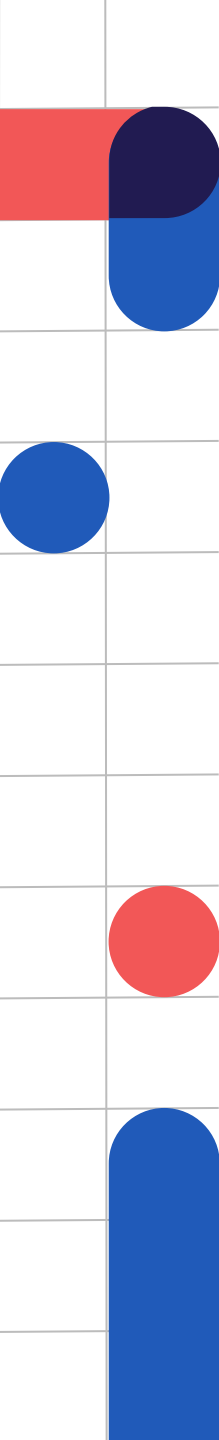

“

Be a Champion!



Pender Public Schools - 2025-2026

Staff Inservice!



Be a Champion - 2025 - Thanking those that champion PPS!

Back to School!



PPS will be serving a light supper on the playground.

WELCOME BACK TO School

Back to School Night
Tuesday, August 12th
6:00-7:30 p.m.

Please enter @ door 4 by office or playground

Elementary bring your supplies & meet your teachers!

- 5:30 pm - Preschool Open House
- 5:30 pm - 7th Grade Transition Meeting in the Event Center
- 6:00 pm - Opening Ceremonies on the playground Everyone please attend!
- 6:15 pm - Technology Meeting in the Event Center for parents of 4-12 graders.
- 6:30 pm - P2T - Parent/Student Meeting in the Event Center

All registration forms can be completed online. All student fees can be paid online. Help with both of these items will be available during open house as well.

High school students can pick up their class schedules from their advisory teacher.

A chalkboard-style graphic with various school supplies like colored pencils, paper clips, and a globe. The text is written in white and pink chalk-like fonts.

25-26 Personal Goals

1. I will regularly visit classrooms to partner with the teachers and students for success.
2. I will utilize professional development experiences to help grow Pender Public Schools.
3. I will champion those around me by choosing positivity and asking questions first, listening second, and speaking third.

If we don't choose positivity, we can't focus on the beauty in people all around us. Keep your head on a swivel with a sharp eye for the wonders woven in those around you.

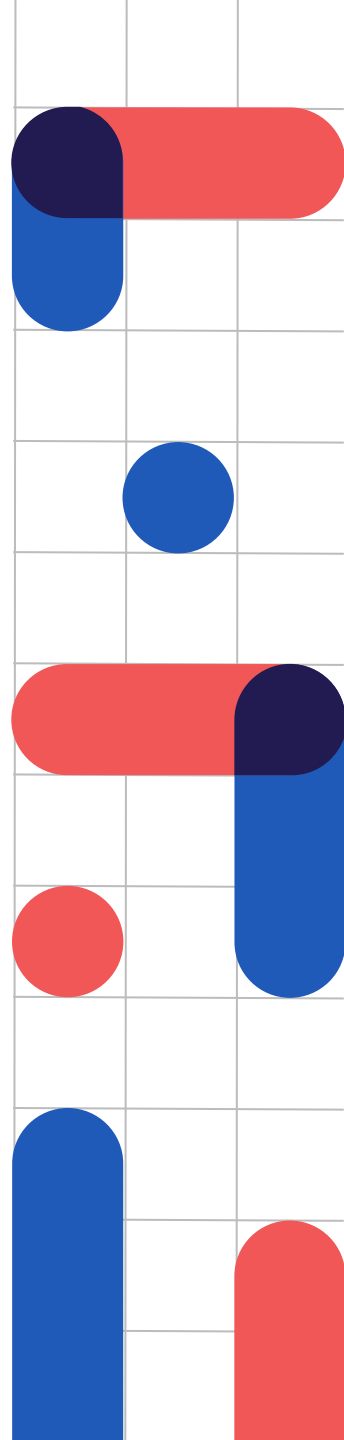

2025/2026 Class Sizes

7th - 34

8th - 31

9th - 34

10th - 32

11th - 41

12th - 28

Total - 199 (+9)



6 new students - 1 departing student

Classroom Breakdown

PENDER SECONDARY SCHEDULE									
	1	2	Adv. Group	3	4	5	6	7	8
	8:10-8:58	9:01-9:49	9:52-10:12	10:15-11:03	11:06-11:54	11:57-1:12	1:15-2:03	2:06-2:54	2:57-3:45
Athey	GEN SCIENCE (11th) 20	PREP	A.G.	CHEM 1 (11th) 17	PHYSIC SCI (9th) 23	PHYSIC SCI (9th) 11	MG STEM 15	GEN SCIENCE (11th) 1	ANATOMY/PHYSICS 9
Christiansen	PREP	LANG MG 1 (7th) 19	A.G.	LANG MG 1 (7th) 13	LANG MG 2 (8th) 14	LANG MG 2 (8th) 15	ENGLISH 1 20	SPEECH BEG 16	ENGLISH 1 12
Conner	SOCIAL STUDIES (7th) 21	SOCIAL STUDIES (7th) 13	A.G.	WORLD HISTORY (10th) 20	AMER GVNMT (12th) 21	WORLD HISTORY (10th) 10	PREP	AMER GVNMT (12th) 5	MG Physical Education 23
Dregalla	CONCERT BAND 22 INSTR MUSIC (MG) 27	SPANISH 1, 2, 3 5	A.G.	SPANISH 1, 2, 3 8	ELEMENTARY SPECIALS	ELEMENTARY SPECIALS	PREP	FINE ARTS MG 16	GUIT 2 / GUIT 1 4
Ferg	AD	PERSONAL FINANCE 16	A.G.	PREP	PSYCH/SOCIOLOGY 2	SPANISH 1, 2, 3 15	MG CAREER DEV. 15	AD	AD
Harpham	TECH	INTRO TO COMPUTER SCIENCE & TECH 16	TECH	TECH	TECH	TECH	TECH	TECH	TECH
Haymart	ENGLISH COMP/LIT (dual credit) 9	ENGLISH 3 (11th) 19	A.G.	ENGLISH COMP/LIT (dual credit) 18	ENGLISH 3 (11th) 21	ENGLISH 2 (10th) 16	ENGLISH 2 (10th) 15	PREP	REFREPS 7
Hinrichs	PREP	SPECIAL EDUCATION	A.G.	SPECIAL EDUCATION	SPECIAL EDUCATION	SPECIAL EDUCATION	SPECIAL EDUCATION	SPECIAL EDUCATION	SPECIAL EDUCATION
Heise	MG STUDY SKILLS 11	YEARBOOK 5	A.G.	MEDIA CENTER	ELEMENTARY SPECIALS	ELEMENTARY SPECIALS	MEDIA CENTER	MEDIA CENTER	SPANISH 1, 2, 3 19
Keiss	SPECIAL EDUCATION 7	SPECIAL EDUCATION 2	A.G.	SPECIAL EDUCATION 11	SPECIAL EDUCATION 1	SPECIAL EDUCATION	SPECIAL EDUCATION 4	SPECIAL EDUCATION	PREP
King	Tech/Bus Math 8	ALGEBRA I (8th/9th) 16	A.G.	PRE ALGEBRA (8th) 14	MATH MG 1 (7th) 17	MATH MG 1 (7th) 17	ALGEBRA I (8th/9th) 10	STATS / COL.TRIG 8	PREP
Kolbeck	CONCERT BAND 49	PRESCHOOL SPECIALS/PREP	A.G.	MG STUDY SKILLS 14	ELEMENTARY SPECIALS	ELEMENTARY SPECIALS	PRESCHOOL SPECIALS/PREP	VOC MUS MG 31	VOCAL MUSIC 32
Krusemark	ART 1,2,3,4 15	PREP	A.G.	ART 1,2,3,4 2	ELEMENTARY SPECIALS	ART 1,2,3,4 6	ART 1,2,3,4 10	FINE ARTS MG 16	ART 1,2,3,4 9
Meister	NARES/WLDLFGMT(11/12) 15	PSTFUND/PWRTECH(12th) 6	A.G.	AG EN-INTR (9th) 24	ANSCI/ANMT (10th) 22	AGBS/LDRSHPÐ(11/12) 6	MG AGRICULTURE 17	PREP	NARES/WLDLFGMT(11/12) 3
Nixon	SCHOOL COUNSELING	SCHOOL COUNSELING	A.G.	SCHOOL COUNSELING	ELEMENTARY SPECIALS	ELEMENTARY SPECIALS	SCHOOL COUNSELING	SCHOOL COUNSELING	SCHOOL COUNSELING
Oliver	PREP	LIFETIME ACTIVITIES 12	A.G.	LIFETIME ACTIVITIES 4	ELEMENTARY SPECIALS	ELEMENTARY SPECIALS	SPANISH 1, 2, 3 23	HEALTH EDUCATION 18	MG Physical Education 14
P2T	No Class	No Class	Travel Morning Group	10:30-12:20. Morning Group - 9	10:30-12:20. Morning Group - 9	Morning/Afternoon Travel Crossover	12:30-2:20. Afternoon Group - 13	12:30-2:20. Afternoon Group - 13	No Class
Ramm	PREP	STRENGTH TRAINING 14	A.G.	STRENGTH TRAINING 5	STRENGTH TRAINING 14	STRENGTH TRAINING 16	MG STRENGTH & CONDITIONING 15	STRENGTH TRAINING 18	STRENGTH TRAINING 15
Steecker	BIOLOGY 1 (10th) 19	SCIENCE MG 2 (8th) 17	A.G.	SCIENCE MG 2 (8th) 13	SCIENCE MG 1 (7th) 17	SCIENCE MG 1 (7th) 17	BIOLOGY 2(dual credit) 4	BIOLOGY 1 (10th) 13	PREP
Volk	GEOGRAPHY (9th) 23	GEOGRAPHY (9th) 12	A.G.	AMERICAN HIST(11th) 14	SOCIAL STUDIES (8th) 15	SOCIAL STUDIES (8th) 15	PREP	AMERICAN HIST (11th) 27	MG Physical Education 22
Von Seggern	CALCULUS (12th) 2	PRE CALCULUS(11th-12th) 19	A.G.	GEOMETRY (9th/10th) 10	ALGEBRA II(10th/11th) 17	GEOMETRY (9th/10th) 19	ALGEBRA II(10th/11th) 24	PREP	SAT STUDY HALL 6



MAPS Testing

- August 18th-29th
- First testing will be tomorrow!
- 7th-10th grade will MAPS test
 - Math, Science, Reading, Language Usage
- NSCAS Testing has changed again!



Pathways to Tomorrow

**22 Students Participating
(9 Morning/13 Afternoon)**

- **Computer Science - 3**
- **Health Sciences - 6**
- **Welding/Construction - 13**
- **Education - 0**

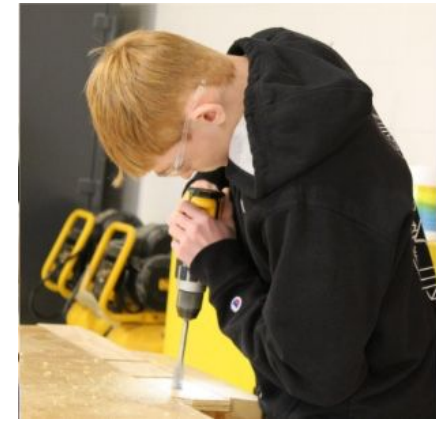

School to Career Program

11 Students Participating

- Proof of Working Required
- Teacher checking in with businesses
- Thank you to the cooperating business

2025 NCA Softball All-Star Game

- **NEN Player**
 - Taylor Scholting
 - Wisner-Pilger
- **Assistant Coach**
 - Mr. Haymart
- **Blue Team wins 7-6!**
- **July 21, 2025**

 2025 NCA Softball All-Stars		
BLUE TEAM		
Leyla O'Connor	Bennington	Pitcher
Caitlyn Semple	Millard West	Pitcher
McKenna Sides	Seward	Pitcher
Bayla Bodnar	Ralston	Catcher
Brylee Rupiper	Gretna	Catcher
Stella Campin	Plattsmouth	1st Base
Carley Stych	Millard North	2nd Base
Mae Mae Zach	Douglas County West	Short Stop
Taylor Scholting	NEN (Wisner-Pilger)	3rd Base
Kinsley Stover	Papio South	Outfield
Anniston Trevarrow	Gretna	Outfield
Shayla Warak	Papio South	Outfield
Adelyn Zwick	Bishop Neumann	Outfield
BLUE TEAM		
Head Coach	Tom Horton, Papillion-La Vista South	
Assistant Coach	Clay Haymart, NEN	
RED TEAM		
Sydney Atkins	Douglas County West	Pitcher
Amanda Gibilisco	Papillion-LaVista	Pitcher
Kylie Baumgard	Norfolk	Catcher
Reyse Zobel	Grand Island Northwest	Catcher
Bridget Whitney	Bishop Neumann	Catcher
Ava Martinez	Lincoln East	1st Base
Brooklynn Gillen	McCook	Short Stop
Meagan Jahde	Blue River	Short Stop
Mary Beth Hart	Lincoln Southwest	Outfield
Kyra Ray	Grand Island Northwest	Outfield
Kaylee Taylor	Fort Calhoun	Outfield
Avery Wolfe	Papillion-LaVista	Outfield
RED TEAM		
Head Coach	Gary Lytle, Beatrice	
Assistant Coach	Elliot Haack, Elkhorn South	
All-Star Ambassadors	Dan Nelson & Jaedyn Ratzlaff	



2025 NCA Basketball All-Star Game

- Pender Player
 - Maya Dolliver
- Red Team Wins
- July 23, 2025

		
2025 NCA Girls Basketball All Stars		
RED TEAM		
PLAYERS		
Hannah Bedient	Lincoln Pius X	Wing
Karlee Broberg	Elkhorn Valley	Wing
Parker Christiansen	Waverly	Forward
Neleigh Gessert	Millard West	Wing
Ava Grimm	DC West	Wing
Anastyn Harms	Waverly	Point Guard
Kimora Jenkins	Omaha Westside	Point Guard
Chloe Koch	York	Wing
Jenna McClain	Fremont	Forward
Ayla Roth	Milford	Point Guard
Myleigh Weers	Diller-Odell	Point Guard
RED TEAM		
Head Coach	Russ Ninemire, DC West	
Assistant Coach	John Cockerill, Waverly	
BLUE TEAM		
Presley Baca	Bennington	Wing
Zailli Benish	Leyton	Point Guard
Maya Dolliver	Pender	Point Guard
Lindsey Emanuel	North Bend Central	Wing
Kaitlyn Freudenberg	Lincoln Southeast	Forward
Norah Gessert	Millard West	Point Guard
Kelsey Hatcher	Kearney	Wing
Keeleigh Knobbe	Lincoln Pius X	Point Guard
Britt Nielsen	Arlington	Forward
Addie Sullivan	Blair	Forward
BLUE TEAM		
Head Coach	Kip Colony, Omaha Skutt Catholic	
Assistant Coach	Tim Barada, Lincoln Southwest	
All-Star Ambassadors	Dan Nelson & Jaedyn Ratzlaff	



2025 Guy Mytty Wrestling Award

The Nebraska Coaches Association
presents this award to:

Coach Dennis Oliver

In Recognition of your outstanding dedication and service to high school wrestling, exemplifying the ideals of which Coach Mytty would have been proud

N nebraska
coaches
association



Girls Golf

- Coach Rainer & Mailloux
- 7 Girls Total Participating
- 6 from Pender & 1 from Bancroft
- First meet is this Thursday at Beemer

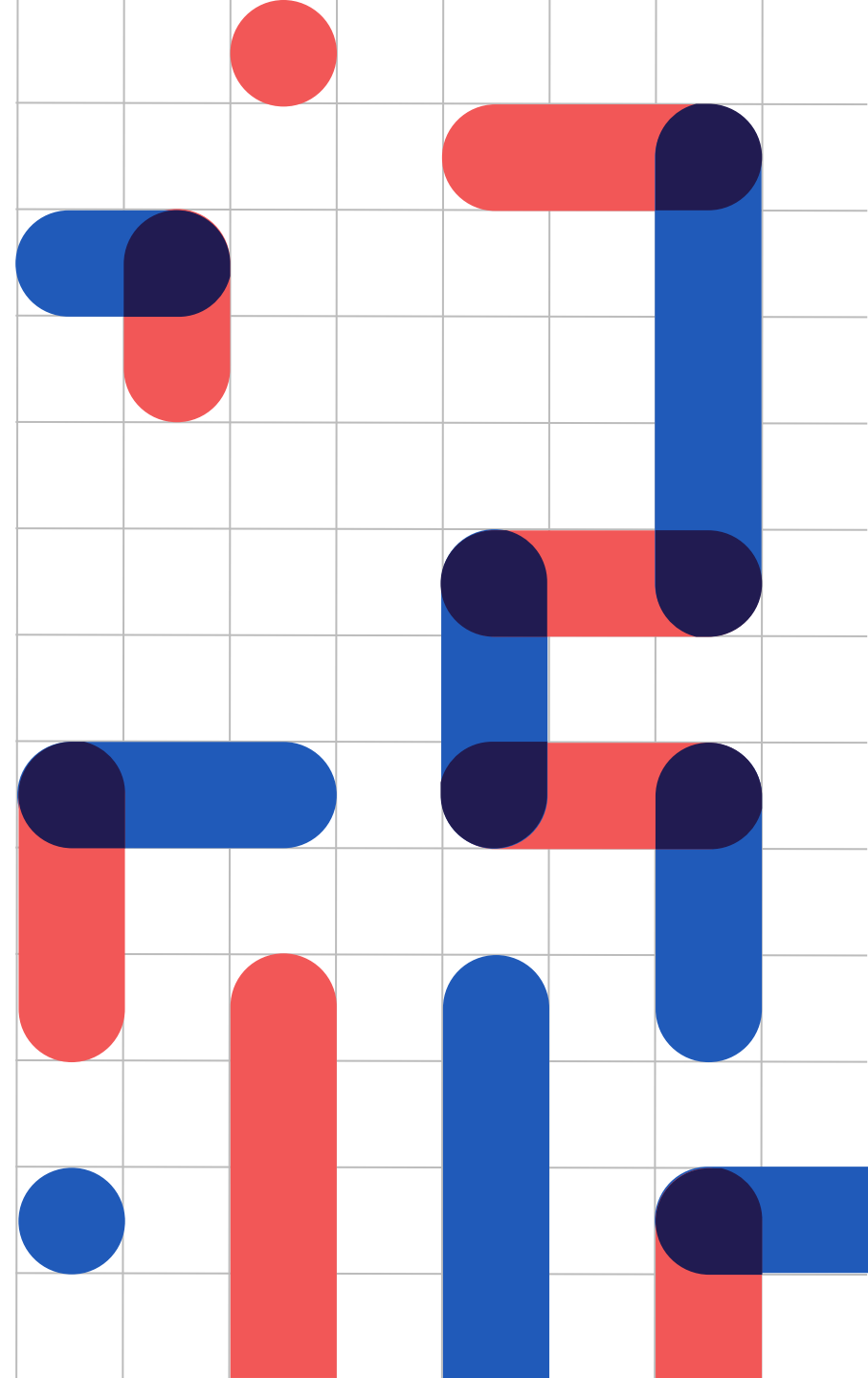

Volleyball

- Coach Mailloux, Jetensky, & Nickels
- 16 Girls Participating
- Jamboree on Tuesday, August 26th vs LDNE

JH Volleyball

- Coach Conner & Trimble
- 23 Total Girls Participating
- 12 Seventh Graders & 11 Eighth Graders
- First Game - Tuesday, September 9th vs Oakland



Football

- Coach Volk, Simonsen, Ramm, Hofmeister, Jorgensen, and Heineman
- 45 Boys Participating
- First Game - Friday, August 29th @ Plainview

JH Football

- Coach Ferg, Arlt, & Volk
- 17 Total Boys Participating
- 10 Seventh Graders & 7 Eighth Graders
- First Game - Monday, September 8th @ Wisner

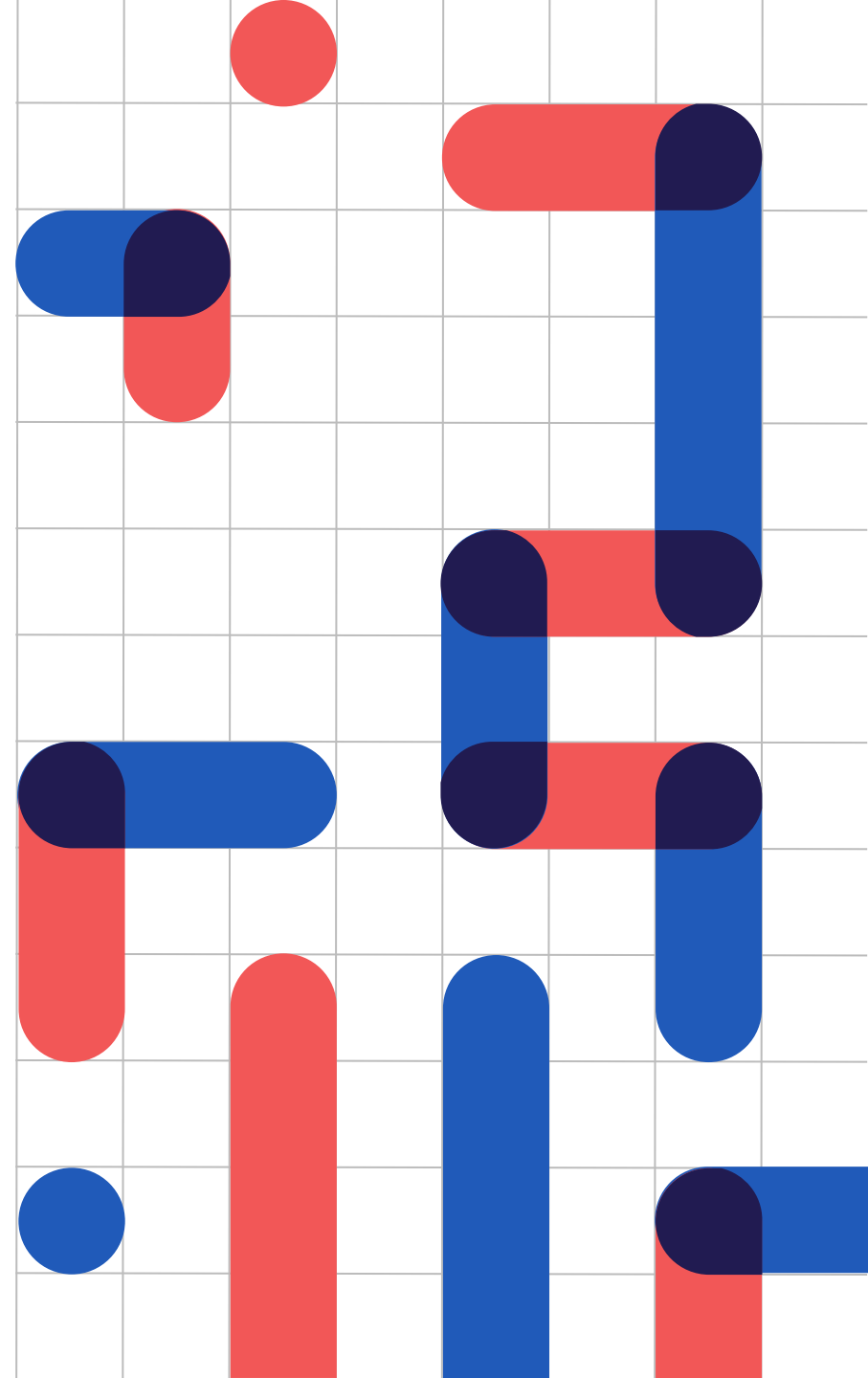

Softball

- Coach Haymart, Timm, Kinnaman, Ras, & Dolliver
- 22 Total Girls Participating
- 15 Girls from Pender and 7 Girls from Wisner
- Jamboree - Tomorrow @ Omaha Westview

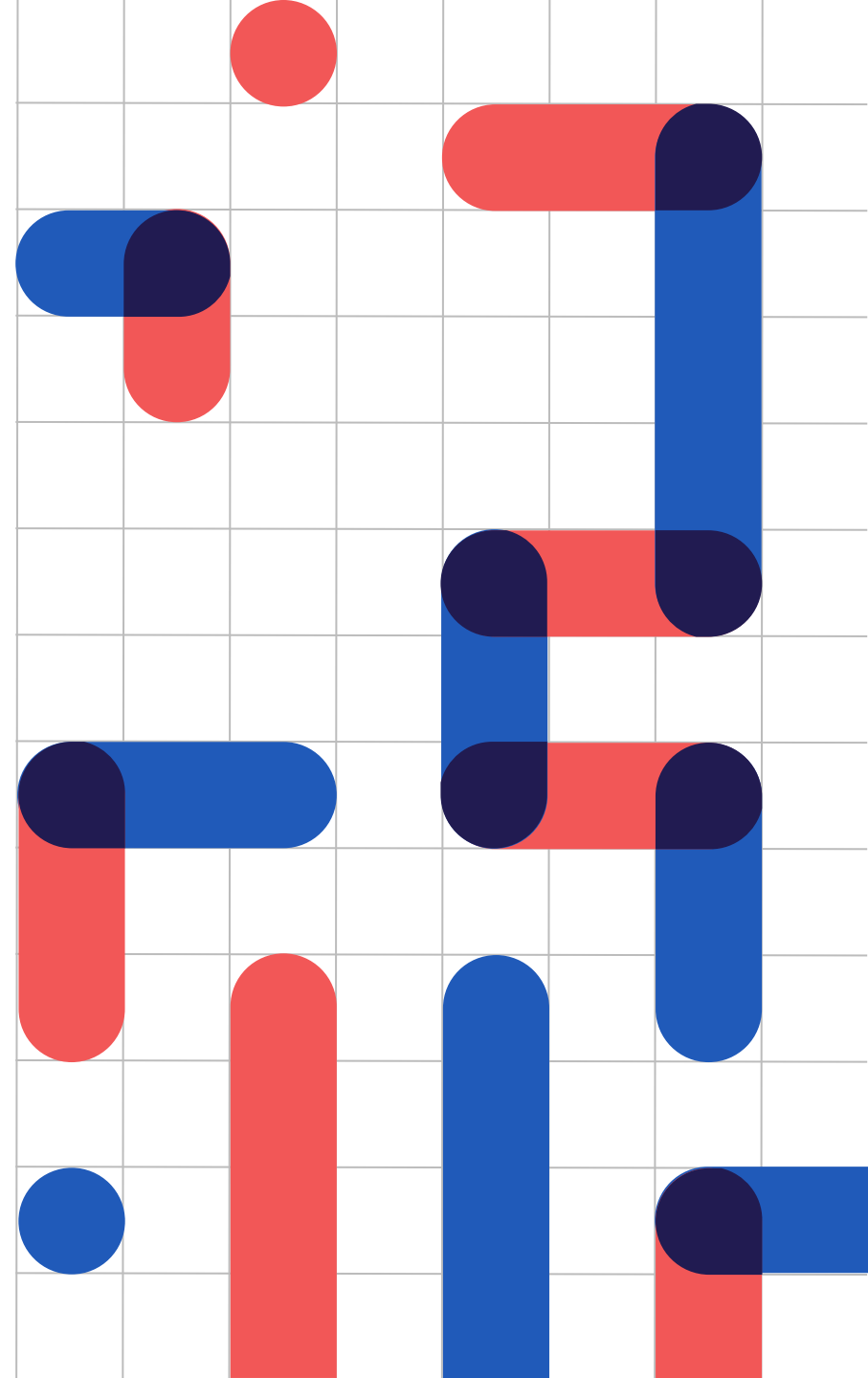

Cross Country

- Coach Krusemark & King
- 9 Students Participating
- 4 Girls and 5 Boys
- 5 Junior High Student
- First Meet - Thursday, August 28th @ Hartington

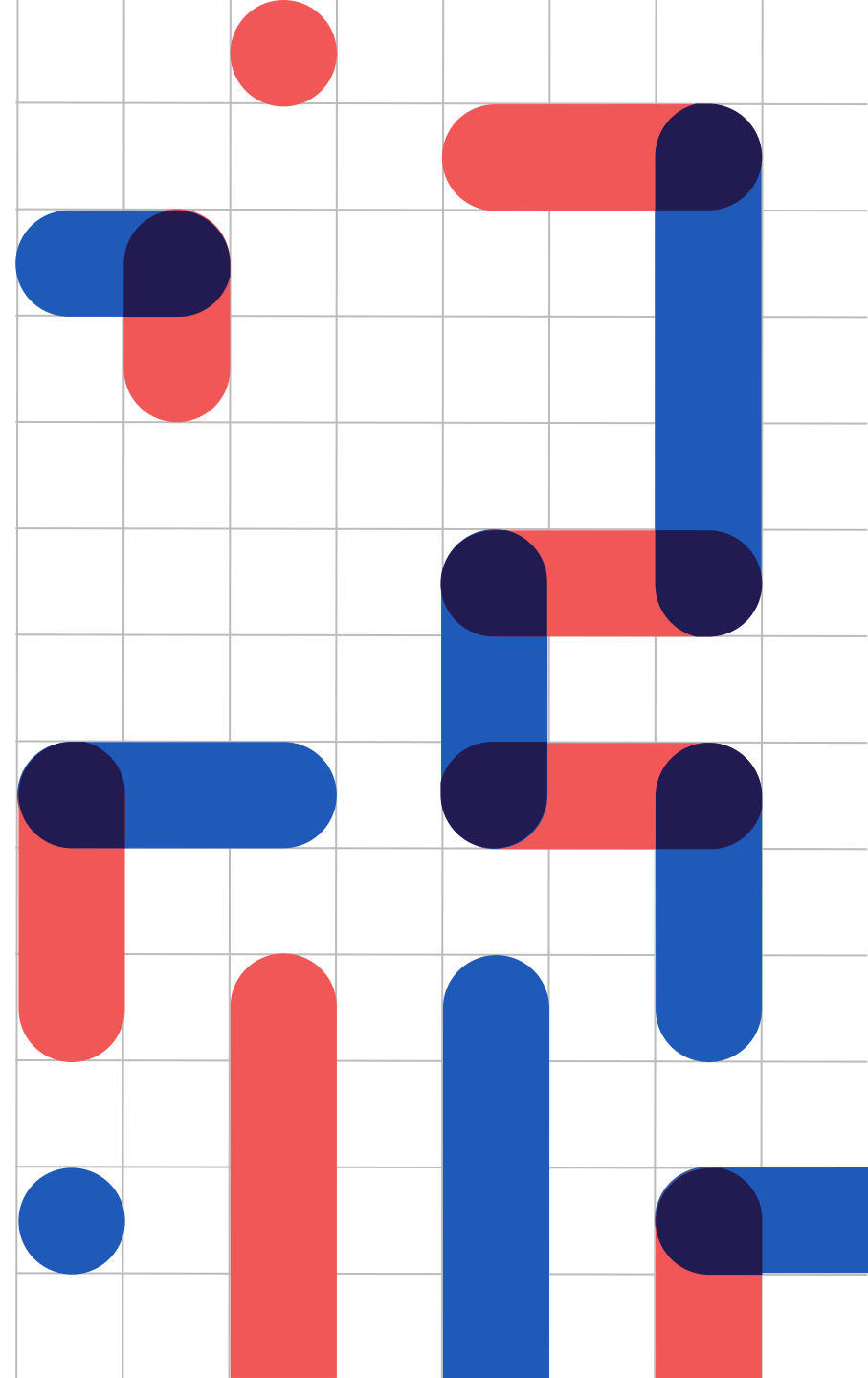

eSports

- Coach Harpham
- 12-15 Students Participating
- Fall & Spring Seasons

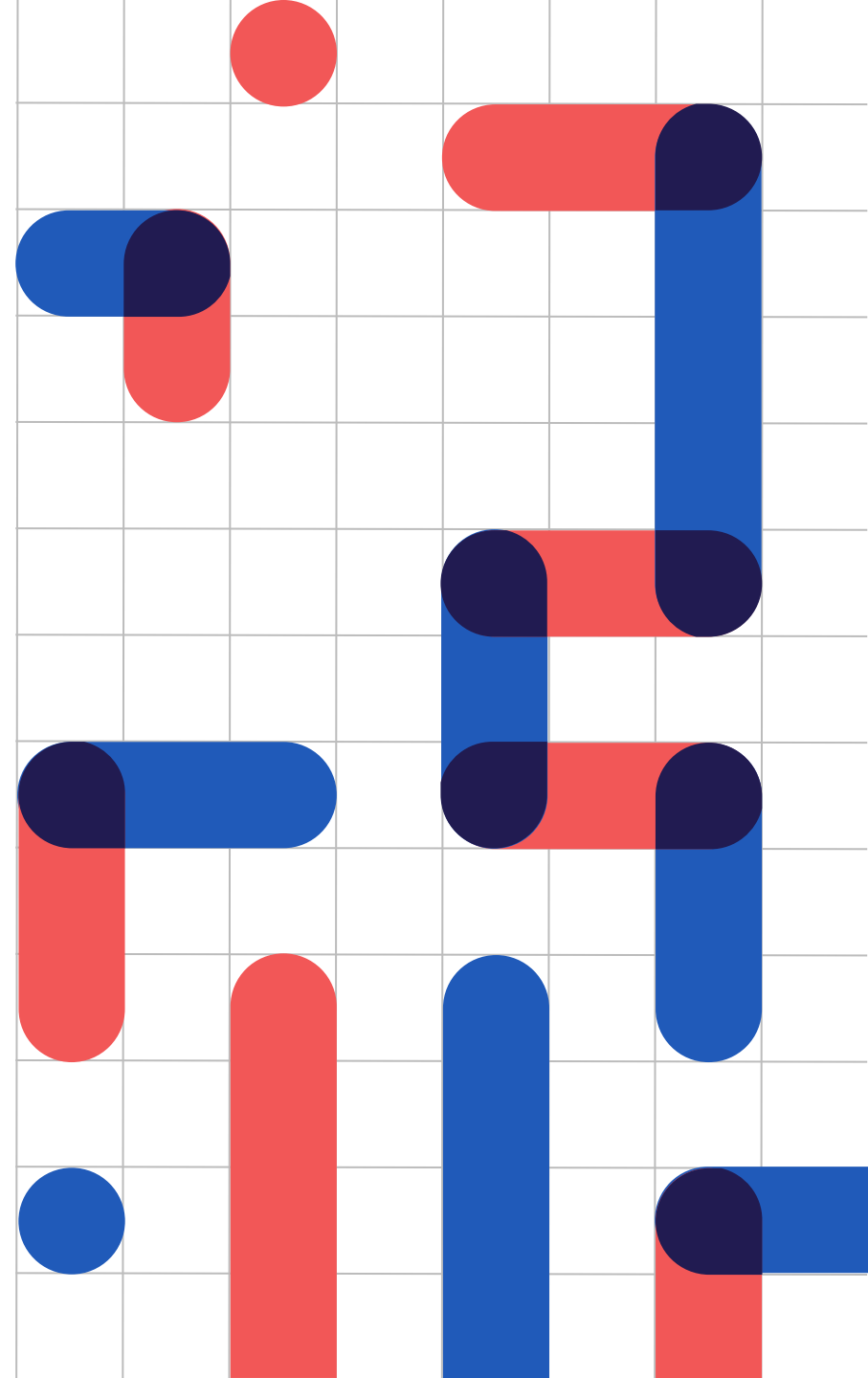

National Honor Society

- Food Bags Sent Home on Fridays
- NHS Kids Rotate and Go Fill Bags
- We are Starting this Year with 63 Bags K-12
- NHS Students also help Tutor after School on Wednesdays



Pendragon PRIDE Program

- This is us!
- Cards sent home
- Nominations for going above and beyond



Thank you!

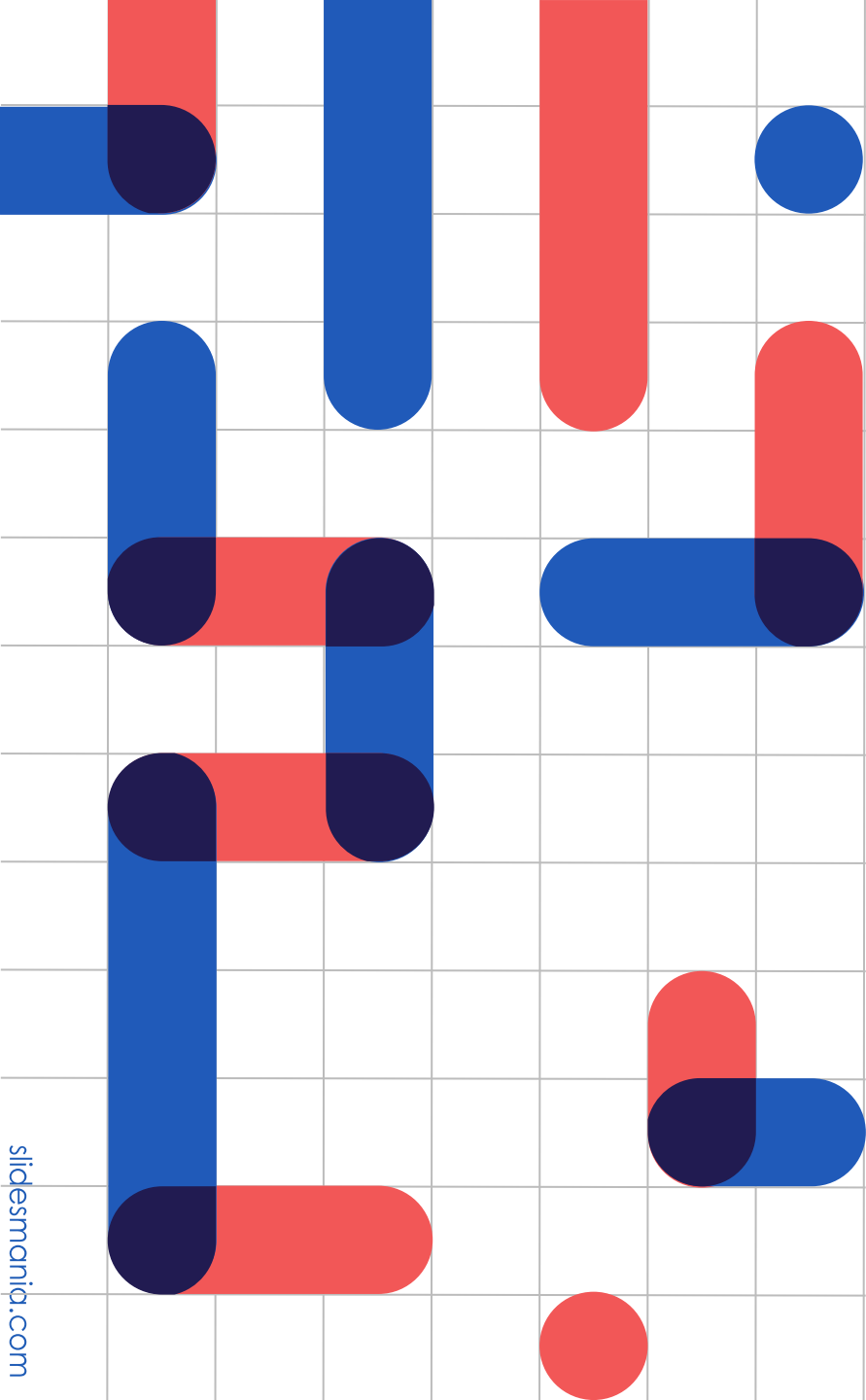

Company Address 2 Constitution Way
Woburn, Massachusetts 01801
United States

Created Date 8/18/2025

Bill To Name Pender Public Schools
Bill To 609 Whitney St
Pender, Nebraska 68047-5036
United States

Order Number 00027333

Billing Frequency Annually

Contract Start Date 9/1/2025

Net Terms 30

Contract End Date 8/31/2028

Customer PO
Required

Term in Months 36

Product	Type	Contract Start Date	Contract End Date	Annual Sales Price	Quantity	Extended Price
enCORE K-12 Student Sub. 1 Yr - Advanced - +10	Software	9/1/2025	8/31/2028	USD 415.00	10.00	USD 12,450.00
enCORE Tier 5 Asynchronous Training Package-1 Yr	Services	9/1/2025	8/31/2028	USD 1,500.00	1.00	USD 1,500.00
enCORE K-2 Teacher Set Bundle - (Units 1-18)	Physical Goods			USD 1,200.00	1.00	USD 1,200.00
enCORE K-5 Manipulative Kit - Units 1-36	Physical Goods			USD 650.00	1.00	USD 650.00
enCORE K-2 Reading Library - Single Copy	Physical Goods			USD 1,400.00	1.00	USD 1,400.00
Social Skills Elementary School - Teacher's Set	Physical Goods			USD 199.00	1.00	USD 199.00
Basics Teacher Set	Physical Goods			USD 199.00	1.00	USD 199.00
Transition to Adulthood Visual Support Kit	Physical Goods			USD 1,299.00	1.00	USD 1,299.00
Transition to Adulthood Teacher Guide	Physical Goods			USD 199.00	1.00	USD 199.00
Shipping and Handling	Shipping	9/1/2025	8/31/2028	USD 308.76	1.00	USD 308.76

Software Subtotal USD 12,450.00

Physical Goods Subtotal USD 5,146.00

Services Subtotal USD 1,500.00

Shipping Total USD 308.76

Sales Tax Total USD 0.00

Grand Total USD 19,404.76



Order Notes

Year 1: \$11,104.76
Year 2: \$4,150.00
Year 3: \$4,150.00

For questions on this order, contact:

TeachTown Representative: Karianna Cooper
Prepared By: Karianna Cooper
Email: kcooper@teachtown.com

Student licenses provide access for a single student to all products within a package.

Unless separate invoice and payment terms are specified, TeachTown will issue an invoice in full for the quoted amount upon execution of a purchase order. For any physical goods that are backordered, invoices will be issued when physical goods are shipped. All payment terms are Net 30.

Professional Services must be utilized within twelve (12) months from date of purchase. If the term is longer than twelve (12) months and Professional Services are purchased for additional term years, Professional Services must be used within the term defined.

By signing this Order Form you are agreeing to our Terms of Service:
<https://web.teachtown.com/terms-of-service/>

How to place an Order:

Email: orders@teachtown.com
Fax: (877) 295-8238
Mail: TeachTown
2 Constitution Way
Woburn, MA 01801

Authorized to Sign
on Behalf of the Org

Quote Acceptance Information

Signature _____
Name _____
Title _____
Date _____

By signing this quote or by submitting a purchase order in accordance with this quote, you hereby consent to a contractual agreement terminating on the above listed subscription expiration date. You are obligated to adhere to the payment conditions listed within this quote through the entirety of the contractual term

PROPOSAL

2025 Micro Bird School Bus
14 Passengers

School Bus

Created for: Pender Public Schools

The quote is valid for: **60 days.**

Delivery: **Estimated 8 months**



NEBRASKA / CENTRAL
EQUIPMENT, INC.
BUS SALES & SERVICE

Quote ID #: 2528313



 MICRO BIRD
"GIARDIN"

2025 **Micro Bird School Bus**
14 PASSENGERS

**Safe-Durable-Quality
Construction**



2025 Micro Bird School Bus

14 PASSENGERS

CHECK HERE FOR LEASE

BODY, OPTIONS AND CHASSIS \$ 102,000.00

YOUR NET PURCHASE PRICE \$ 102,000 - pricing valid for 60 days

PREPAYMENT OPTIONS:

100%: \$ _____ Prepayment Discount, Deduct..... < \$ No Prepay >

Please check the box & sign here if you would like to take advantage of our pre-pay discount.

Sign Here: _____

OPTIONAL EQUIPMENT: Included in the final price

1.	Standard Warranty package included in price		Included
2.	GMC Chassis		Included
3.	6.6 Liter Gasoline Engine with Automatic Transmission		Included
4.	14 Passenger Capacity		Included
5.	Heated, Remote Mirrors		Included
6.	Trade Credit of \$60,000 to Be Applied If Purchased. \$42,000 Total Cost After Trade.		Credit

ACCEPTANCE FOR (School or Organization):

SIGNATURE:

PRINTED:

TITLE:

DATE:

By: Jamie Egger

Date: 6/19/2025

ESTIMATED COMPLETION DATE: 8 Months

ADD 30 EXTRA DAYS FOR AIR CONDITIONING

ALL RESPONSIBILITIES OF OWNERSHIP AND LIABILITY ARE TRANSFERRED TO CUSTOMER AT DELIVERY ~ TERMS: NET CASH ON DELIVERY

PURCHASE ORDER ACKNOWLEDGEMENT

25-0651 00 REV: B

G.M.

**G5 SCHOOL BUS
14 PASSENGERS**

SOLD TO: **NEBRASKA/CENTRAL EQUIPMENT**
112 APOLLO STREET
P.O. BOX 3
ALDA
NE 68810

VEHICLE DESCRIPTION:

U.S.
CHEVY / GMC
GM GAS 6.6L (32G)
G5
159" DRW 5 ROWS 76" WHEEL WELL
NO HANDI DOOR
HIGH WINDOWS FOR 74"/75"/76" BODY
DOD 32"
SCHOOL BUS

STATE SPEC: NEBRASKA
CHASSIS YEAR: 2025
BODY YEAR: 2025

CERTIFICATION: SCHOOL BUS
CERTIFICATION STATE: NE

PREPARED BY: GRACIELA MILLAR

CONTROL ID: RV-48452
LIST CODE: 5T
PRICE LIST: 2025-02

DATE: FEBR-26-25
QUOTE: 071337



P.O.A. : 25-0651 00 REV: B

G.M.
G5 SCHOOL BUS
14 PASSENGERS

CONTROL ID: RV-48452 250226 PAGE: 4 OF 7

NEBRASKA/CENTRAL EQUIPMENT

Body - Base

Option	Description	Price	Option	Description	Price
ALI	ALIGNMENT		LGM-DS	DEC BIRD BLACK	
BUA-1	BACKING SAFETY HORN SAE 112DBA		LGZ	STEPWELL LED LIGHT	
BUC-1	BACKUP CAMERA W/SCREEN IN MIRROR		LLP-L	LICENSE PLATE LIGHT LED	
BU1-S	BUMPER REAR - STEEL 3/16		LN2-3M	REFLECTORS REAR RED - 3M	
BWP	BLACK AROUND WARNING LAMPS PAINT 3"		LST-L	STOP & TAIL LED LIGHTS	
BW1	PANEL BELOW WINDOW - ALUMINUM		L2N-1	RR DOOR LATCH/SLIDE BAR/3 POINT	
B45	BODY WHEEL HOUSING DW G5 76"		MVW	MORE VIEW CLR GLASS TP	
CPO	CHASSIS PREPARATION		PAG	FUEL FILLER POT	
CST	STRUCTURAL CAGE		PEY	PAINT EXTERIOR SCHOOL BUS YELLOW	
DFO	DECAL "?????? FUEL ONLY"		PRW5	PAINT ROOF WHITE G5	
DMB-EY	DECAL MICRO BIRD ENG YLW BACK		PSBC	PAINTED ENT/STEP BODY COLOR MATCH	
EDG	CLEAR GLASS ENTRANCE DOOR		P2S	SELECT PLYWOOD 1/2INCH	
EEC	DOD ELECT CONTROL		RDB	EMERGENCY EXIT AJAR BUZZER	
EIB	DECAL EMERGENCY DOOR		RDR	TELESCOPIC RETAINER REAR DOOR	
ESK	EXTERIOR SKINS		RD2	RR DOOR 2 GLASSES	
EWF	EXT WINDOW TRIM		RFCF	FRONT CAP SB OR COM STANDARD	
EXB	RELOCATE EXHAUST TO REAR		RFCR	REAR CAP SB OR COM STANDARD	
E32	DOUBLE OPENING DOOR 32 IN		RFT-Y-3M	REFLEC TAPE EMER/D YELLOW 3M	
FDC	FORD OR GM CONSOLE W/SWITCHES		RRF	RUB RAIL FLOOR LEVEL	
FGL	INT & EXT FINISHING PARTS		RRN	RUB RAIL BLACK	
FGSW-Z	SMOOTH GREY FLR WHT NOSE ZEN		RRS	RUB RAIL SEAT LEVEL	
FSR-1	STANDARD FRONT STRUCTURE		RSR-1	REAR STRUCTURE STANDARD	
FS1	FLOOR STEEL GALVANIZED 14GA		SFS	STANDARD FLOOR STRUCTURE	
GCS	ENTR GRAB LH 1 1/2 IN SS PLAIN		SKG	SIDE SKIN SUPP & M/FLAP	
GLC	GLOVE COMPARTMENT		SLND	ELEC SYS W/SOLENOID 200A	
GRG	GRAVEL SHIELDS MOLDED		SRT-S	CENTRAL SPEAKERS IN CEILING	
GUT	DRIP RAILS		SSM1	STOP ARM SMI STOP INCANDESCENT	
GVWR-123	GVWR 12,300LB GM		SV1	STATIC ROOF VENT	
HHNC	HEATER HOSE ONLY (1X)		SWH	WHEEL HOUSINGS STEEL	
HSF-1	HEAT SHIELD FOR FUEL TANK DELETE		TWD	KIT REFLEC (3)	
IM	INT MIRROR 6X16 IN		US	U.S. SCHOOL BUS VEHICLE	
ISF	INT FRONT SKINS STD		WHT	WHEEL WELL TRIM BLACK	
ITST	INTERIOR FINISH STANDARD		WPI	8 WAY WIRING POWER ON IGNITION	
LAH-S	STANDARD LED DOME LIGHTS		WSQ	SEQUENTIEL 8WAY SYSTEM	
LBU-L	BACK-UP LIGHTS LED		WSS-S	WIRING SYSTEM STANDARD	
LCL-L	IDENTIF. & CLEARANCE LIGHTS LED		8WS	8 WAYS STANDARD (4 AMBER 4 RED)	
LDN-L	DIRECTIONAL LED LIGHTS NO ARROW				



P.O.A. : 25-0651 00 REV: B

G.M.
G5 SCHOOL BUS
14 PASSENGERS

CONTROL ID: RV-48452 250226 PAGE: 5 OF 7

NEBRASKA/CENTRAL EQUIPMENT

Body - Requirements

Option	Description	Price	Option	Description	Price
BFK	BODY FLUID KIT FEDERAL		MUD	MUDFLAPS STANDARD	
BU2	BUMPER REINFORCEMENTS		NE	NEBRASKA	
DDBB	DECAL 2" BLACK BUMPER 45 DEGRE		PFB	HPADS GREY FIREBLOCK	
DG2	DRIVE LINE GUARD FRONT/REAR		PGY	PAINT CHASSIS GRILL YELLOW	
2 DPU-Y-3M	DECAL+TAPE P/O US YELLOW 3M		RRSK	RUB RAIL SKIRT	
DSB	DECAL -SCHOOL BUS- REFLEC 3M		RSS1	ROOF HATCH SPHEROS SMART	
EX2	EXTINGUISHER 5 LBS		SBC	SEAT BELT CUTTER	
FAK	FIRST AID KIT FEDERAL SPEC U.S		T1R-3M	REFL TAPE 2IN RR PERIM YLW 3M	
F2A-1	2-SPD FAN RH ABOVE WINDSHIELD		T2S-3M	REFL TAPE LAT 2" YELLOW - 3M	
HS1	DOD STEP DE-ICING		UC2	UNDERCOATING BODY AND CABIN FLOOR	
LE2-L	SIDE DIRECT.LED LIGHTS ARMORED YEL		V40-1	SHUT-OFF VALVE W/CABLE UNDER BODY	
LI5-7	WHT STROBE LED ON BAT W/GUARD		V50	HEATER VALVE BLEEDER	
LN3-3M	REFLECTORS 3" AMBER SIDE 3M		WHGS-Z	WHEEL HOUSE COVERING GREY ZENITH	
ME2	PREWIRE FOR 2 WAY RADIO				

Body - Options

Option	Description	Price	Option	Description	Price
AA-30TG	A/C SPH 30K+OEM EVA/RR/GR NO COND		7 LEGS-S	LEG CEW	
2 AKC	ADDITIONAL KEY CHASSIS		MRSHR-Z6	MIRROR ROSCO SB HTD/REM W/TIMER	
ATR	AISLE TRIM ALUMINUM		RDW2-G	REAR DOOR GLASS (2) DARK TINT 26%	
BBX-DXT17	BBX DELETE W/BAT AUX ON RIGHT		RF8	LEFT STD ALU RUNNINGBOARD PAINTED	
BH36LA8000	HSM BAR 36 LH HB BLU FB WO/C		RHL	OEM RADIO WITH MICROBIRD SPEAKERS	
BH36RA8000	HSM BAR 36 RH HB BLU FB WO/C		7 SBK2	SEAT BELT KIT FOR (2) PASSENGERS	
HDA	HEATER REAR 42000BTU		4 SH36LA8026	HSM STD 36 LH HB BLUE FB WO/C	
ISRR-5	INT FINISH RR W/A/C SPHEROS 35K		3 SH36RA8026	HSM STD 36 RH HB BLU FB WO/C	
ITC-P1RS	PNT ROOF SKINS 1 R/H SPEAKERS STD		WBC	WIN S/S TINT 26% W/2 P/O	
KFR	36 IN KICK PANEL UNDER RH BARRIER		WRC	2 BACK WINDOWS DARK TINT (26%)	



P.O.A. : 25-0651 00 REV: B

**G.M.
G5 SCHOOL BUS
14 PASSENGERS**

NEBRASKA/CENTRAL EQUIPMENT

Chassis

Option	Description	Price	Option	Description	Price
ABS	4 WHEEL DISC BRAKES WITH ABS		R05	DUAL REAR WHEELS	
AJ3	AIR BAG DRIVER'S SIDE ONLY		R6H	GM UPFITTER ALLOWANCE	
AS5	SEAT FRONT BUCKET WITH CLOTH TRIM		TC	TRANSPORTATION CHARGES	
BA3	CONSOLE WITH SWING OUT STORAGE		TGK	SPECIAL PAINT	
BNC	BODY MOUNT CUSHIONS (PUCK)		TP3	DUAL BATTERIES EACH 770 AMPS	
B3D	SCHOOL BUS CHASSIS EQUIPMENT		UE0	ONSTAR DELETE	
C60	FRONT DASH AIR		UJ1	BRAKE WARNING INDICATOR	
C7N	12300 LBS GVWR		U0F	RADIO AM/FM WITH MP3	
DTRL	DAYTIME RUNNING LAMPS		U05	HORN DUAL NOTE TONE	
D31	TILT REARVIEW MIRROR		VK3	LICENSE PLATE BRACKET	
ENC-HVAC	PROV.AUX.HEATER PLUMBING & WIRING		VQ2	FLEET PROGRAM	
FE9	EMISSIONS FEDERAL SPECS		VTP	VOLMETER TEMPERATURE & OIL PRESSURE	
FTC-21	FUEL TANK 32 GALLONS / 121.1 LITERS		V4D	STOP TURN SIGNAL CIRCUITS	
GT4	REAR AXLE RATIO: 3.73		XHF	TIRE FRONT LT225/75R16E ALS B/L DRW	
JL4	STABILITRAK SYSTEM		ZX1	HIGH BACK BUCKET DRIVER'S ONLY	
KC4	COOLING EXTERNAL ENGINE OIL COOLER		01U	EXTERIOR PAINT YELLOW	
KW5	ALTERNATOR 220 AMPS		1WT	EQUIPMENT GR 1WT MDEL 3500 / GAS	
K05	ENGINE BLOCK HEATER		159	159" WHEELBASE	
L8T	ENGINE GAS 6.6L V8		4300	FRONT GAWR 4300 LBS	
NB8	EMISSION OVERRIDE (NY FE9)		8E8	FRONT BUMPER PAINTED BLACK	
NST	WITHOUT SPARE TIRE		8600	REAR GAWR 8600 LBS	
N8X	8 SPEED HD TRANSMISSION		9L7	ACCESSORY POWER CIRCUITS	
PWS	POWER STEERING		9T7	RIGHT SIDE DOOR DELETE	
QT4	WHEEL 16 X 6.5 STEEL HD DRW		93G	TRIM CLOTH MEDIUM DARK PEWTER	

Miscellaneous

Option	Description	Price	Option	Description	Price
1 025	21.00 % ON BODY AND OPTIONS				
1 026	FOB PLANT				
1 056	MARKET ADJUSTMENT				

Order Changes

Option	Description	Price	Option	Description	Price
REVISION: A ()					
1	add LBU-L				
REVISION: B (RV-48452)					
1	place order				



Detailed Seat Description

Qty	Option	Description
1	BH36LA8000	CEW BARRIER STANDARD RIGID HI 36 /LEFT SIDE COLOR: /LVL: 1 BLU BLUE FIREBLCK
1	BH36RA8000	CEW BARRIER STANDARD RIGID HI 36 /RIGHT SIDE COLOR: /LVL: 1 BLU BLUE FIREBLCK
4	SH36LA8026	CEW SCHOOL STANDARD RIGID HI 36 /LEFT SIDE COLOR: /LVL: 1 BLU BLUE FIREBLCK /LIGHT PACKAGE /LATCH
3	SH36RA8026	CEW SCHOOL STANDARD RIGID HI 36 /RIGHT SIDE COLOR: /LVL: 1 BLU BLUE FIREBLCK /LIGHT PACKAGE /LATCH



IMPORTANT NOTICE / AVIS IMPORTANT
 VEHICLE CONFIGURATION AND CAPACITY ARE SUBJECT TO CHANGE TO REFLECT ANY AND ALL CHASSIS SPECIFICATIONS OF THE MODEL YEAR UTILIZED.
 LA CONFIGURATION ET LA CAPACITÉ DE CE VÉHICULE SONT SUJETTES À DES MODIFICATIONS AFIN DE TENIR COMPTE DES SPÉCIFICATIONS DU CHÂSSIS DE L'ANNÉE MODÈLE UTILISÉ.

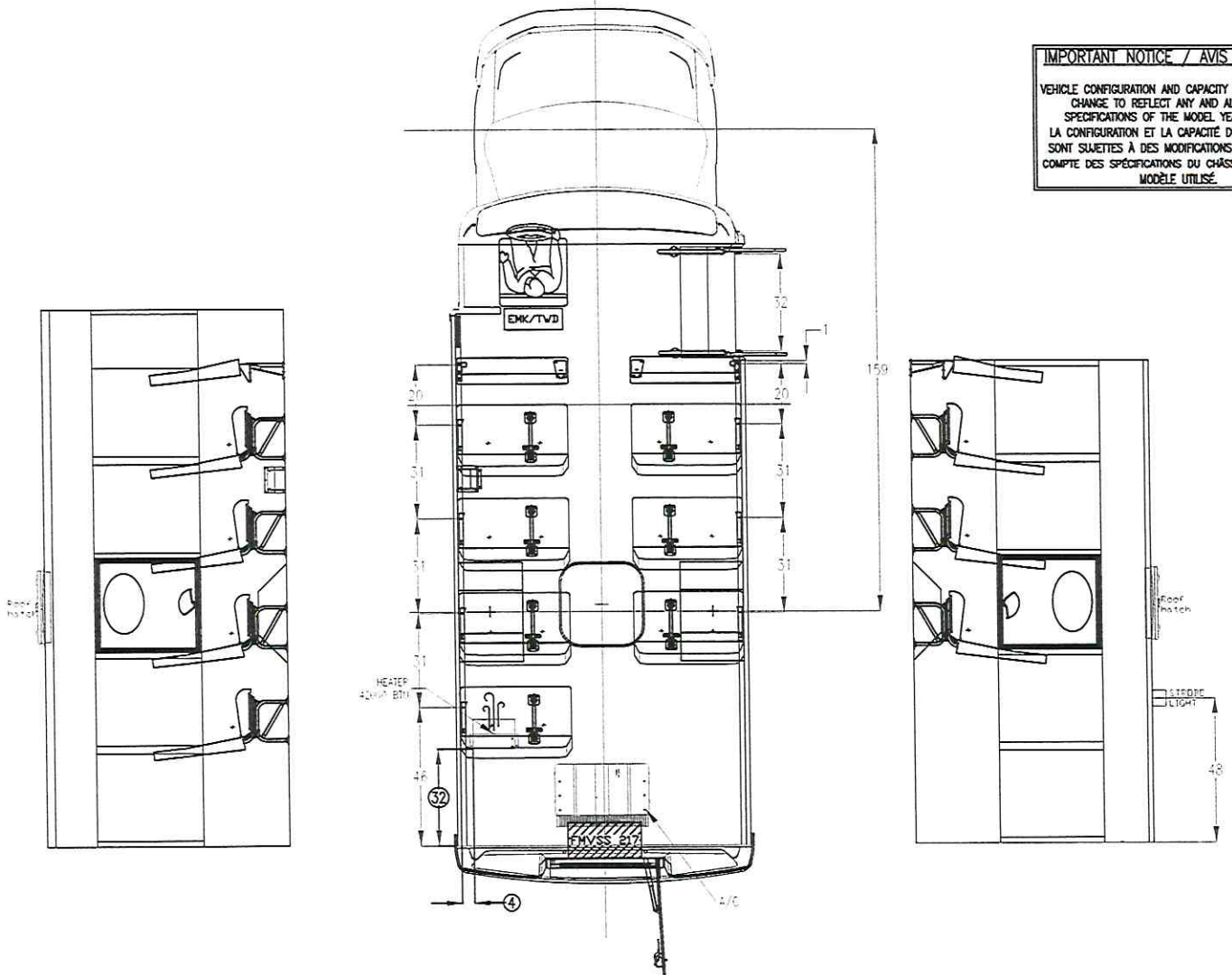

SEAT	DIM.	SIDE	QTY
SH	36	LH	4
SH	36	RH	3

Seat spacing =	See drawing	D.O.D.:	32"
APPROVED CONFIGURATIONS			
Total ambulatory passengers :	14	Total wheel chair passengers :	0
Load cap. (pass. + cargo) :	1723kg		3799lbs

A	2025/02/25	SG	DRAWING CREATION
REV.	YYYY/MM/DD	BY	DESCRIPTION

Stock Number:	
Customer Approval:	<i>Jamie Egger</i>
Date:	2025-02-27

Drawn by:	SABRINA GALERIO	
MODEL:	UGU5 2NH WSV	
UNIT = INCHES	Drawing no.	
SCALE = DO NOT SCALE	F06943A	
<small>NOTED: Any option added to this floorplan shall be approved by the Corporation Micro Bird Inc technical department.</small>		

American Commercial Furniture, LLC
8070 Castleton Rd
Unit 521
Indianapolis IN 46250





Shipping Address:

Pender Public Schools, Deanna Hansen
609 Whitney Street
Pender NE 68047
United States
☎ +1 402-385-3244 ext. 2103

Need a W9? [Download a Copy](#)

Quotation # SO15926

Quotation Date:	Expiration:	Salesperson:	Deliver By Deadline:	Do Not Deliver Before:
07/16/2025	07/25/2025	Justin Sosbe	No Deadline Specified	OK to Ship When Ready

Product Image	Description	Quantity	Unit Price	Taxes	Amount
<i>NOTICE: Due to the uncertainty surrounding potential tariffs, quotes are valid for one week. Proposed tariffs may result in significant price increases on certain products, so please take this into consideration when making decisions.</i>					
	[1034662] Staging 101 4-Tier Wedged Folding Choral Risers with Guardrail - Carpet Finish	4 Unit(s)	2,451.00	7.00%	\$ 9,804.00
	[1034647] Staging 101 Brackets for Connecting Wedged to Wedged Risers - 4 Pack	3 Unit(s)	19.39	7.00%	\$ 58.17
	[1010428] Staging 101 4' x 8' Carpet Finish Stage Panel - 8" High Screw-In Legs	1 Unit(s)	809.40	7.00%	\$ 809.40
	[1010432] Staging 101 4' x 8' Carpet Finish Stage Panel with Tip and Roll Wheels - Adjustable Height: 16" or 24"	2 Unit(s)	946.20	7.00%	\$ 1,892.40

Ships in 2-3 Business Days
IntelliStage 2 Year Warranty Handled by American Commercial Furniture

	Tailgate Freight with Limited Access (School)	1 Unit(s)	1,799.90	7.00%	\$ 1,799.90
--	---	-----------	----------	-------	-------------

*****To Be Unloaded from Truck Height by Customer's Own On-Site Forklift**

American Commercial Furniture, LLC
8070 Castleton Rd
Unit 521
Indianapolis IN 46250

Untaxed Amount	\$ 14,363.87
Tax 15%	\$ 0.00
Total	\$ 14,363.87

Acceptance of Quote:

By submitting a purchase order or purchase letter reflecting this quote, Buyer is hereby accepting the below Sales Agreement and terms of the Seller. In the event that the Sales Agreement is not signed, the purchase order or purchase letter will act as the Buyer's signature and acceptance.

Sales Agreement

This Sales Agreement ("Agreement") is made between efurnitureMax, LLC DBA American Commercial Furniture ("Seller") and the signed ("Buyer") on the sales quote confirmation date ("Effective Date").

Seller and Buyer agree as follows:

Quote Accuracy: Seller makes its reasonable efforts to ensure that the quote attached to this Agreement and made a part hereof as Exhibit 1 ("Quote") reflects the Buyer's requested items, options, and quantities. It is the Buyer's responsibility to verify that all items, product options, and quantities in this Agreement and/or the Quote are accurate. Buyer agrees Seller will not be held liable for any Quote inaccuracies or financial consequences of inaccuracies for Quotes that have been reviewed and accepted by the Buyer. Any Buyer accepting and using Seller's Quote, whether in a Purchase Order, or otherwise, also accepts this Agreement in its entirety.

Order Cancellation: Buyer acknowledges that this Sales Agreement may not be eligible for cancellation once submitted and processed for fulfillment. Seller will use its commercially reasonable effort to honor any cancellation request of Buyer, but Buyer must strictly follow Seller's return policy, in part as outlined in this Agreement, if it is too late to cancel. Custom products that have already entered production may incur sizeable restocking fees, or may not be eligible for cancellation, depending on how far along in the production process they have advanced. Any changes to this Agreement after acceptance may incur fees, for which the Buyer is responsible (re-routing after shipment, adding delivery services, etc.).

Payment: Prepayment via credit card, check, or bank transfer is required to secure this Agreement, unless the Buyer is offered terms. Purchase Orders with net 30 terms are accepted from schools, government organizations, and some companies, but will require preapproval. All delinquent invoices are subject to 1.5% interest per month. Any tax imposed by federal, state, or other governmental authority on the sale of the merchandise and service referred to on this order shall be paid by the Buyer. Transfer of title and/or ownership and/or use rights of any kind in the products and items of each and every kind proposed to be sold by Seller to Buyer under this Agreement (collectively, "Goods") shall not pass to Buyer until Buyer has paid in full the purchase price to Seller.

American Commercial Furniture, LLC
8070 Castleton Rd
Unit 521
Indianapolis IN 46250

Delivery Deadline & Do Not Deliver Before: All provided lead times are estimates. Items may ship early and at different times than other items on the order. If a hard delivery deadline exists, Buyer is responsible to ensure that the "Delivery Deadline" field on the quote accurately reflects the deadline. Buyer also agrees to accept order items early unless specified a specified "Do Not Deliver Before" date is set. Seller will not be responsible for any order deadlines or do not ship before requests unless it is clearly noted on the quote within these fields.

Delivery: Orders will ship via FedEx/UPS, or via LTL freight carrier, depending on the size of the shipment or item (s). If free freight is offered, it includes FedEx Ground, UPS Ground, and tailgate freight only. The Buyer will be responsible for unloading all LTL freight shipments from the tailgate, and shall bear all risk of loss associated with same, unless additional services are requested at the time of ordering. Additional freight services such as a lift gate or inside delivery are available upon request, for an additional charge. Any delivery services added at the time of delivery will be billed to the Buyer at cost.

Damages & Shortages: For all freight shipments, any damages or shortages must be noted on the delivery receipt before signing to be eligible for a claim. Seller must be notified within 24 business hours of any freight damage or shortages due to the limited window that freight carriers provide for filing a claim. Please note that any damages or shortages not written on the delivery receipt are subject to the carrier's grace. Seller cannot be held liable for any freight damages or shortages not noted at the time of delivery. For FedEx/UPS shipments, please notify Seller within 5 days of receipt if there is damage.

Shipment Refusals: The Buyer is responsible for any return shipping costs due to shipment refusals, or undeliverable shipments. The Buyer is also responsible for any restocking fees charged by the manufacturer due to a refusal. If the item is not eligible for return, the shipment will be refused by the manufacturer and the Buyer will incur all charges.

Returns: Non-custom and made to order items are eligible for return within 30 days of receipt. Custom products are not eligible for return due to their nature. All Goods and items must be returned in the original condition, and in original packaging. All returns must be preauthorized and accompanied by an RMA number for identification. Returns over \$1,000 will incur a restocking fee of 35%. The Buyer is responsible for arranging and paying for return shipping of any standard return, unless the return is a result of a Seller's error. Please see full policy: <https://www.americancommercialfurniture.com/returns>

Venue/Governing Law/Fees/Jury Trial: This Agreement has been made and shall be construed and interpreted in accordance with the laws of the State of Indiana, and any dispute of any kind relating to, connected with or arising out of this Agreement in any fashion ("Dispute") shall only be heard and decided exclusively in the Superior Courts of Marion County, Indiana, and Buyer waives any (i) objection to such exclusive venue, and (ii) right it may have to a trial by jury in respect of any legal action arising out of or relating to this Agreement. Buyer agrees to reimburse Seller for Seller's reasonable attorneys' fees, costs, and expenses of any kind in connection with such Dispute.

Defective Products/Disclaimer: Within 30 days, the Seller will either replace or refund any defective products or parts that

American Commercial Furniture, LLC
8070 Castleton Rd
Unit 521
Indianapolis IN 46250

comprise Goods, using Seller's discretion, with replacement as a priority. After 30 days, products and parts that comprise Goods are subject to the warranty as provided by the manufacturer, and information regarding manufacturer's warranty may be found on/in manufacturer's website, catalogues and other materials, and/or by contacting manufacturer directly. The Seller provides complimentary warranty service and will facilitate a warranty claim on behalf of the Buyer, but cannot take responsibility for the final resolution as these decisions are up to the manufacturer. EXCEPT FOR THE EXPRESS WARRANTIES IF ANY SET FORTH IN THIS AGREEMENT, SELLER MAKES NO WARRANTY WHATSOEVER WITH RESPECT TO THE GOODS, INCLUDING ANY (a) WARRANTY OF MERCHANTABILITY; (b) WARRANTY OF FITNESS FOR A PARTICULAR PURPOSE; (c) WARRANTY OF TITLE; OR (d) WARRANTY AGAINST INFRINGEMENT OF INTELLECTUAL PROPERTY RIGHTS OF A THIRD PARTY; WHETHER ARISING BY LAW, COURSE OF DEALING, COURSE OF PERFORMANCE, USAGE OF TRADE, OR OTHERWISE. BUYER ACKNOWLEDGES THAT IT HAS NOT RELIED UPON ANY REPRESENTATION OR WARRANTY MADE BY SELLER, OR ANY OTHER PERSON ON SELLER'S BEHALF, EXCEPT AS SPECIFICALLY PROVIDED IN THIS AGREEMENT.

Miscellaneous: This Agreement shall be binding upon and inure to the benefit of the parties hereto and their respective heirs, personal representatives, successors and permitted assigns. The section and paragraph headings contained herein are for convenience of reference only and are not intended to define, limit or describe the scope or intent or any provision of this Agreement. This Agreement constitutes all of the understandings and agreements of whatsoever nature or kind existing between the parties with respect to the Goods. This Agreement cannot be modified or changed except by another agreement in writing signed by Seller and Buyer. Nothing contained in this Agreement shall constitute or be construed to be or create a partnership or joint venture between the Seller or its successors or assigns, and the Buyer or its successors or assigns. This Agreement may be terminated at any time by Seller. The Seller, its members, managers, officers, agents, and employees, shall not be liable to any person for any action or omission, negligent, tortious or otherwise, of any agent or employee of the Seller or the Buyer in the performance of this Agreement, except to the extent such acts are determined to have been the result of the fraud, gross negligence, or intentional misconduct of any of the Seller or the Seller's members, managers, officers, agents, and employees, and the Buyer hereby agrees to indemnify, defend and hold harmless the Seller, its members, managers, officers, agents, and employees, from and against any liability, loss, damage, cost or expense (including reasonable attorneys' fees) by reason of any such act or omission except to the extent such acts are determined to have been the result of the fraud, gross negligence, or intentional misconduct of any of the Seller or the Seller's members, managers, officers, agents, and employees. Notwithstanding anything in this Agreement to the contrary, all of the obligations of the Seller contained in this Agreement are limited in that the Seller is only required to use its reasonable efforts to accomplish the desired result or to prevent the undesired result, and the liability of the Seller for breach of the provisions of this Agreement shall be limited to gross negligence or willful violations of such obligations. The Buyer shall provide written notice to Seller of any purported breach or default of Seller within ten (10) days of the time it first comes to the knowledge of Buyer, otherwise such shall be deemed waived. Buyer shall at all times comply with all laws applicable to this Agreement, Buyer's performance of its obligations hereunder, and Buyer's use or sale of the Goods. Without limiting the generality of the foregoing, Buyer shall (a) at its own expense, maintain all certifications, credentials, licenses, and permits necessary to conduct its business relating to the purchase or use of the Goods and (b) not engage in any activity or transaction involving the Goods, by way of shipment, use or otherwise, that violates any law. Seller makes no guarantee, warranty or representation of any kind. Buyer agrees it shall have no setoff rights of any kind. EXCEPT FOR

American Commercial Furniture, LLC
8070 Castleton Rd
Unit 521
Indianapolis IN 46250

OBLIGATIONS TO MAKE PAYMENT UNDER OR COMPLY WITH THIS AGREEMENT, SELLER'S AGGREGATE LIABILITY ARISING OUT OF OR RELATED TO THIS AGREEMENT, WHETHER ARISING OUT OF OR RELATED TO BREACH OF CONTRACT, TORT (INCLUDING NEGLIGENCE) OR OTHERWISE, SHALL NOT EXCEED THE TOTAL OF THE AMOUNTS PAID TO SELLER PURSUANT TO THIS AGREEMENT. WITHOUT LIMITING THE GENERALITY OF THE FOREGOING, BUYER ASSUMES ALL RISK AND LIABILITY FOR THE RESULTS OBTAINED BY THE USE OF ANY GOODS, WHETHER IN TERMS OF OPERATING COSTS, GENERAL EFFECTIVENESS, SUCCESS OR FAILURE, AND REGARDLESS OF ANY ORAL OR WRITTEN STATEMENTS MADE BY SELLER, BY WAY OF TECHNICAL ADVICE OR OTHERWISE, RELATED TO THE USE OF THE GOODS.

Buyer has (i) read and agree to the terms of this Agreement, including but not limited to the medical and weight capacity disclaimers attached hereto and made a part hereof as Exhibit 2, and (ii) reviewed the Quote for accuracy of items, quantities, prices, and product options, and agrees with and accepts Agreement and Quote.:

Buyer- _____

Signature: _____ Date: _____

If electronically signed, the date is the date of quote acceptance and online signature.

EXHIBIT 1

Quote- See Above

EXHIBIT 2

medical and weight capacity disclaimers

Medical Disclaimer:

Seller specializes in heavy duty, big & tall seating for demanding work environments. Seller does not advertise its products as a solution for those with medical or mobility issues. If you have a medical or mobility issue, we advise you to seek a seating solution from a medical solutions provider and discuss your needs with a medical professional. Our products are not designed for this purpose.

Seller chairs are designed for typical office use only. They should not be used as a mobility tool, such as a wheelchair or as a walker. Users must have the necessary mobility to appropriately stand up and sit down in the office chair. To stand up, users must do so under their own strength, or use an adequate table for support, not a part of the chair. The armrests, backrest, and other components of our office chairs are not designed to withstand a user's entire weight in the action of standing up or sitting down. Most office chairs are designed with wheels and are expected to move or tip if force is applied unevenly on the chair - bracing on a single armrest, etc. This action poses a dangerous risk for those with mobility issues and who may fall if the chair shifts under inappropriate use.

American Commercial Furniture, LLC
8070 Castleton Rd
Unit 521
Indianapolis IN 46250

Seller does not advertise its products as a solution for chronic pain, back surgeries, or arthritis. For individual with specific needs relating to pain, we highly suggest looking for a medical-specific furniture solution. Seller specializes in heavy duty chairs designed for the office and will be comfortable for standard office use, but do not contain any special features to accommodate medical issues.

All office chairs offered by Seller are to be used at the user's own risk. By ordering with us, you agree to not hold Seller responsible nor liable for damages incurred through use of one of our office chairs.

Weight Capacity Disclaimer and Definitions:

As a dealer in heavy duty, commercial furniture, weight capacity is a common specification on most of our products. Weight capacities advertised should be assumed as static load capacities unless otherwise noted in the product description.

Static Load Capacity: Static load refers to the weight of an object, all things stationary. If you set an item on a table, or sit in a chair, the static load is the weight once the load has settled and is no longer moving.

Dynamic Load Capacity: Dynamic load capacity refers to the weight of a load, assuming it is moving. For example, dropping a 40 LB bag of sand will have a force greater than 40 LBs until the load settles on the surface it lands on. For seating, the act of sitting down can increase the load exerted on a chair, depending on how much the user "falls" into the chair and the weight of the user. For tables, any machinery with moving parts that will rest on the table, will add the load weight. The act of setting an object on a table will also increase the load weight.

In addition, all weight capacities assume a load is evenly distributed across the surface of the item. Loads not evenly distributed will decrease effective static load capacity of any item. Highly unbalanced loads can pose a safety issue.

Please use this guidance accordingly when making decisions regarding which products will be suitable for your use. Buyer assumes all responsibility for determining the static weight capacity needed for their application. Seller shall not be held liable for product failures not adhering to static load capacity guidance.

StageDrop LLC
 706 Challenger Way, Forked River, NJ 08731
 Tel: 609-971-9200, Fax: 609-971-1650
 www.stagedrop.com | sales@stagedrop.com
 Tax ID: 46-0977080

Quote Date: 8/1/2025
Quote Expires: 8/14/2025
Project Name: Pender Public Schools
Terms: Prepay
Buyer: Brandi Kolbeck
Salesperson: Kristy S.



Billing Address

Brandi Kolbeck
 Pender Public Schools
 tbd
 Wayne, NE 68787
 United States
 (402) 369-6354

Shipping Address

Brandi Kolbeck
 Pender Public Schools
 tbd
 Wayne, NE 68787
 United States
 (402) 369-6354

Order Details

Image	Item Description	Quantity	Price	Total
	National Public Seating TransPort 4-Level Tapered Choral Riser and Guard Rail Bundle	4	\$1,807.73	\$7,230.92
	FREE GIFT: StageDrop Frisbee!	1	\$0.00	\$0.00
			Subtotal:	\$7,230.92
			Economy Freight (NPS-NJ):	\$975.00
			Sales Tax:	\$0.00
			TOTAL BALANCE DUE:	\$8,205.92

Pricing Note: Due to upcoming supplier price increases, we cannot guarantee these prices beyond the quote expiration date. We encourage you to finalize your order before 8/14/2025 to lock in the current rates.

If you have any questions or would like to proceed with an order, please call us at (609) 971-9200 or email sales@stagedrop.com. We are open Monday - Friday, 10am-5pm ET.

StageDrop LLC
706 Challenger Way, Forked River, NJ 08731
Tel: 609-971-9200, Fax: 609-971-1650
www.stagedrop.com | sales@stagedrop.com
Tax ID: 46-0977080

Quote Date: 8/1/2025
Quote Expires: 8/14/2025
Project Name: Pender Public Schools
Terms: Prepay
Buyer: Brandi Kolbeck
Salesperson: Kristy S.

Billing Address

Brandi Kolbeck
Pender Public Schools
tbd
Wayne, NE 68787
United States
(402) 369-6354

Shipping Address

Brandi Kolbeck
Pender Public Schools
tbd
Wayne, NE 68787
United States
(402) 369-6354

Order Details

Image	Item Description	Quantity	Price	Total
	Staging 101 4'x8' Mobile Folding Stage, Adjustable Height (8"-24"), Industrial	9	\$1,960.00	\$17,640.00
			Subtotal:	\$17,640.00
			Free Economy Freight Over \$3900:	\$0.00
			Discount: Education Discount	-\$529.20
			Sales Tax:	\$0.00
			TOTAL BALANCE DUE:	\$17,110.80

Pricing Note: Due to upcoming supplier price increases, we cannot guarantee these prices beyond the quote expiration date. We encourage you to finalize your order before 8/14/2025 to lock in the current rates.

If you have any questions or would like to proceed with an order, please call us at (609) 971-9200 or email sales@stagedrop.com. We are open Monday - Friday, 10am-5pm ET.

Wenger Corporation
 555 Park Drive
 Owatonna, MN 55060-4940
 United States



C O R P O R A T I O N

Phone: 507-455-4100
 Fax: 507-455-4258

Quote Number: 3360956

(4) Sets of 4 step Signature Risers

QUOTE

Date: 05/29/2025
 Page: 1 of 2
 Cust #: 00002850

<p>Quote To: Brandi Kolbeck Pender Public School 609 Whitney St Pender NE 68047-5036 United States</p> <p>Phone: (402) 385-3244 Fax: E-Mail: brkolbe1@penderschools.org</p>	<p>Date: 5/29/2025 Expires: 6/28/2025 Reference: Terms: Deposit Required Created By: Jennye Savoie</p> <p>Salesperson: Lisa Lewis Phone: E-Mail: Lisa.Lewis@wengercorp.com</p>
--	--

Quote Comments:

To place the order a 50% down payment and signed quote are required.

** Wenger is an approved vendor for Region 4 ESC/OMNIA Partners, Public Sector. All items on this quotation are available through Contract #R240120. This contract is in effect through 12/31/2027. Payment shall be made after satisfactory performance, in accordance with all the provisions thereof, and upon receipt of a properly completed invoice. All transactions, purchase orders, etc. will occur directly between the Supplier, authorized distributor/dealer, general contractor, as agreed to by each Participating Public Agency. Per OMNIA participation requirements, all purchase orders issued to Wenger Corporation must reference OMNIA contract #R240120.*

Customer to check and verify all items before ordering.

Freight quoted is for a one-time shipment. As a result, once orders placed, delivery dates may change. Customer-requested split shipments will result in an additional freight charge.

Wenger Corporation expressly incorporates by reference all of the terms and conditions as specified at: (www.wengercorp.com/terms-and-conditions.php) and makes them part of this quotation.

Current estimated lead-time is 2 weeks plus transit, subject to change.

Tariffs, Taxes, Duties, Fees and Permits Imposed: With respect to any product purchase hereunder, if any federal, state or local Tariff, Tax, Duty, Fee or Permit is imposed by Applicable Law on the Seller in connection with any such purchase, then the Buyer shall be required to pay to Seller such additional costs

USD

Line	PartNum/Description	Qty	Net Price	Ext. Price
1.00	098H054 Signature 4-Step Choral Riser	4 EA	\$2,543.00	\$10,172.00
2.00	Freight Freight Services	1 EA	\$1,220.64	\$1,220.64

LIFTGATE DELIVERY:
Freight reflected in this quotation is for common carrier shipment with liftgate delivery.

Wenger Corporation
555 Park Drive
Owatonna, MN 55060-4940
United States



C O R P O R A T I O N

Phone: 507-455-4100
Fax: 507-455-4258

Quote Number: 3360956

(4) Sets of 4 step Signature Risers

QUOTE

Date: 05/29/2025
Page: 2 of 2
Cust #: 00002850

Liftgate delivery means the carrier driver will lower the products to curbside where your facility staff are responsible for taking the products from curbside into the building to the desired location and for completing the final assembly/installation.

Inside delivery and installation services are available. Contact your Wenger sales representative to discuss these delivery methods and to find out the appropriate charge.

If you are a tax-exempt organization and quote includes tax, please send a copy of your tax-exempt certificate and we will remove the sales tax. Thank you.

If you would like to convert this quotation for the materials listed above to an order, please review carefully to ensure that it is correct. The Terms of Sale are shown on the enclosed form. Please sign and return this form so Wenger Corporation may process your order.

*Purchase Order: (if applicable)
Buyer on behalf of:
Authorized Signature:
Printed Name:
Title:
Date:
Email:
Phone:*

Please confirm the facility name and address to which the items are to be shipped:

*Facility Name:
Address:
City:
State:
Zip:*

For CREDIT CARD purchases: It is our top priority to securely gather and protect your credit card information. If you wish to purchase using your credit card, please contact your sales representative, who will directly enter the card type, card number, expiration date, security code and card holder's name.

For purchase by CHECK, please remit to:

*Wenger Corporation NW 7896
PO Box 1450
Minneapolis, MN 55485-6370*

Lines Total \$11,392.64
Total Taxes \$0.00

Quote Total \$11,392.64



MUSIC EDUCATION AND PERFORMING ARTS

Owatonna Office: Phone 800.4WENGER (493-6437) Worldwide +1.507.455.4100 | Parts & Service 800.887.7145 | wengercorp.com | 555 Park Drive, PO Box 448 | Owatonna | MN 55060-0448

Syracuse Office: Phone 800.836.1885 Worldwide +1.315.451.3440 | jrclancy.com | 7041 Interstate Island Road | Syracuse | NY 13209-9713

ATHLETICS Phone 800.493.6437 | email gearboss@wengercorp.com | gearboss.com | 555 Park Drive, PO Box 448 | Owatonna | MN 55060-0448

Wenger Corporation
 555 Park Drive
 Owatonna, MN 55060-4940
 United States



C O R P O R A T I O N

Phone: 507-455-4100
 Fax: 507-455-4258

Quote Number: 3360954

4x8 StageTek Decks, include 5th legs, legs, connectors

QUOTE

Date: 05/29/2025
 Page: 1 of 3
 Cust #: 00002850

<p>Quote To: Brandi Kolbeck Pender Public School 609 Whitney St Pender NE 68047-5036 United States</p> <p>Phone: (402) 385-3244 Fax: E-Mail: brkolbe1@penderschools.org</p>	<p>Date: 5/29/2025 Expires: 6/28/2025 Reference: Terms: Deposit Required Created By: Jennye Savoie</p> <p>Salesperson: Lisa Lewis Phone: E-Mail: Lisa.Lewis@wengercorp.com</p>
--	--

Quote Comments:

To place the order a 50% down payment and signed quote are required.

** Wenger is an approved vendor for Region 4 ESC/OMNIA Partners, Public Sector. All items on this quotation are available through Contract #R240120. This contract is in effect through 12/31/2027. Payment shall be made after satisfactory performance, in accordance with all the provisions thereof, and upon receipt of a properly completed invoice. All transactions, purchase orders, etc. will occur directly between the Supplier, authorized distributor/dealer, general contractor, as agreed to by each Participating Public Agency. Per OMNIA participation requirements, all purchase orders issued to Wenger Corporation must reference OMNIA contract #R240120.*

Customer to check and verify all items before ordering.

Freight quoted is for a one-time shipment. As a result, once orders placed, delivery dates may change. Customer-requested split shipments will result in an additional freight charge.

Wenger Corporation expressly incorporates by reference all of the terms and conditions as specified at: (www.wengercorp.com/terms-and-conditions.php) and makes them part of this quotation.

Current estimated lead-time is 2-3 weeks plus transit, subject to change.

Tariffs, Taxes, Duties, Fees and Permits Imposed: With respect to any product purchase hereunder, if any federal, state or local Tariff, Tax, Duty, Fee or Permit is imposed by Applicable Law on the Seller in connection with any such purchase, then the Buyer shall be required to pay to Seller such additional costs

USD

Line	PartNum/Description	Qty	Net Price	Ext. Price
1.00	280A200.154 StageTek Rectangular Deck Cracked Ice 4'x8', Center Brace & Center Leg Pocket	9 EA	\$865.45	\$7,789.05
<i>***Cracked Ice quoted***</i>				
2.00	280B101.102 StageTek Fixed Leg 8" Elevation 5-Pack	3 EA	\$28.50	\$85.50

Wenger Corporation
555 Park Drive
Owatonna, MN 55060-4940
United States



C O R P O R A T I O N

Phone: 507-455-4100
Fax: 507-455-4258

Quote Number: 3360954

QUOTE

Date: 05/29/2025
Page: 2 of 3
Cust #: 00002850

4x8 StageTek Decks, include 5th legs, legs, connectors

3.00	280B101.104 StageTek Fixed Leg 16" Elevation 5-Pack	3 EA	\$52.25	\$156.75
4.00	280B101.105 StageTek Fixed Leg 24" Elevation 5-Pack	3 EA	\$71.25	\$213.75
5.00	281A340 STAGETEK,CONNECT,2 LEG,RECT	18 EA	\$32.30	\$581.40
6.00	Freight Freight Services	1 EA	\$1,059.17	\$1,059.17

TAILGATE DELIVERY with STAGING:

Freight reflected in this quotation is for common carrier shipment with tailgate delivery. Tailgate delivery will require your staff to unload the truck, move the product into the building and complete any assembly or installation.

LIFTGATE DELIVERY NOT AVAILABLE FOR STAGING, See unloading recommendations.

DO YOU REQUIRE INSIDE DELIVERY OR INSTALLATION SERVICES?

If you do not have a loading dock or staff available to unload the products from the common carrier trailer, then contact your Wenger sales representative to discuss these delivery methods and to find out the additional charges.

If you are a tax-exempt organization and quote includes tax, please send a copy of your tax-exempt certificate and we will remove the sales tax. Thank you.

If you would like to convert this quotation for the materials listed above to an order, please review carefully to ensure that it is correct. The Terms of Sale are shown on the enclosed form. Please sign and return this form so Wenger Corporation may process your order.

Purchase Order: (if applicable)

Buyer on behalf of:

Authorized Signature:

Printed Name:

Title:

Date:

Email:

Phone:

Please confirm the facility name and address to which the items are to be shipped:

Facility Name:

Address:

City:

State:

Zip:

For CREDIT CARD purchases: It is our top priority to securely gather and protect your credit card information. If you wish to purchase using your credit card, please contact your sales representative, who will directly enter the card type, card number, expiration date, security code and card holder's name.

Wenger Corporation
555 Park Drive
Owatonna, MN 55060-4940
United States



Phone: 507-455-4100
Fax: 507-455-4258

Quote Number: 3360954

4x8 StageTek Decks, include 5th legs, legs,
connectors

QUOTE

Date: 05/29/2025
Page: 3 of 3
Cust #: 00002850

*For purchase by CHECK, please remit to:
Wenger Corporation NW 7896
PO Box 1450
Minneapolis, MN 55485-6370*

Lines Total \$9,885.62
Total Taxes \$0.00

Quote Total \$9,885.62



MUSIC EDUCATION AND PERFORMING ARTS

Owatonna Office: Phone 800.4WENGER (493-6437) Worldwide +1.507.455.4100 | Parts & Service 800.887.7145 | wengercorp.com | 555 Park Drive, PO Box 448 | Owatonna | MN 55060-0448

Syracuse Office: Phone 800.836.1885 Worldwide +1.315.451.3440 | jrclancy.com | 7041 Interstate Island Road | Syracuse | NY 13209-9713

ATHLETICS Phone 800.493.6437 | email gearboss@wengercorp.com | gearboss.com | 555 Park Drive, PO Box 448 | Owatonna | MN 55060-0448

Signature® Choral Risers

- 3-Step 098H053 232 lb (105 kg)
4-Step 098H054 320 lb (145 kg)
- Load rating of 150 lb live load capacity per ft² (732 kg capacity per m²)
- Steel construction for unparalleled stability and quiet performance
- Portable units are designed for one-person mobility and setup
- 3-Step riser storage depth is 31" deep x 68" high x 72" wide (787 x 1727 x 1829 mm)
4-Step riser storage depth is 31" deep x 77-1/4" high x 78" wide (787 x 1962 x 1981 mm)
Nesting of additional units reduces storage depth
- Both the 3-Step and 4-Step models have a 42" (1067 mm) high back rail that meets OSHA standards; risers fold with the back rail attached
- Riser frame, back rails and side rails have a black powder-coat paint finish for maximum safety and durability
- Steps are 18" (457 mm) deep and the rise of each step is 8" (203 mm); steps are covered with manufacturer's standard grey carpet
- Built-in reversibility allows for straight or semi-circular configuration
- Designed for in-facility use and easily fits through standard doorways; units have built-in swivel action wheels for maneuvering in tight spaces
- Optional side rail accessory (set of 2) 098G541 62 lb (28 kg) attaches to the riser and back rail; side rail can be removed with the mounting brackets left attached during storage
- Assembly is required, approximate assembly time is 45 minutes for the first unit and 30 minutes for each additional unit; assembly videos are available at www.wengercorp.com
- Fifteen-year warranty
- Patented design

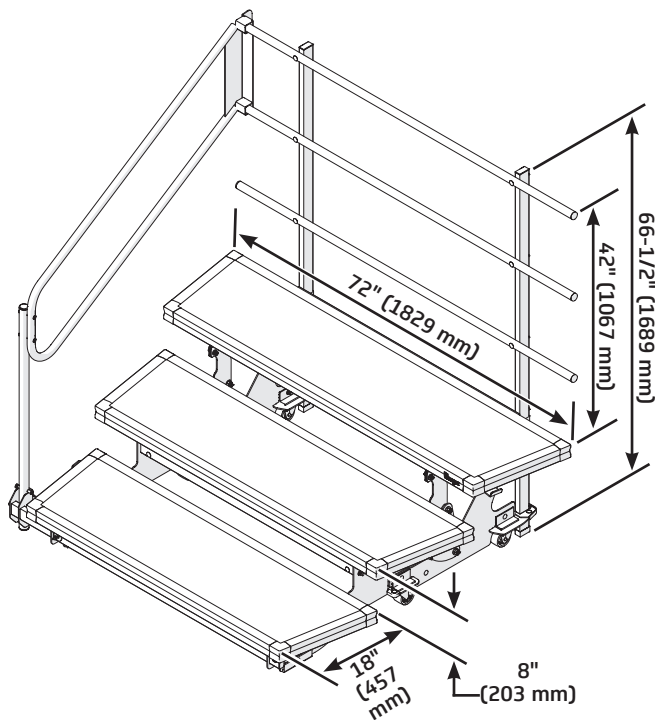
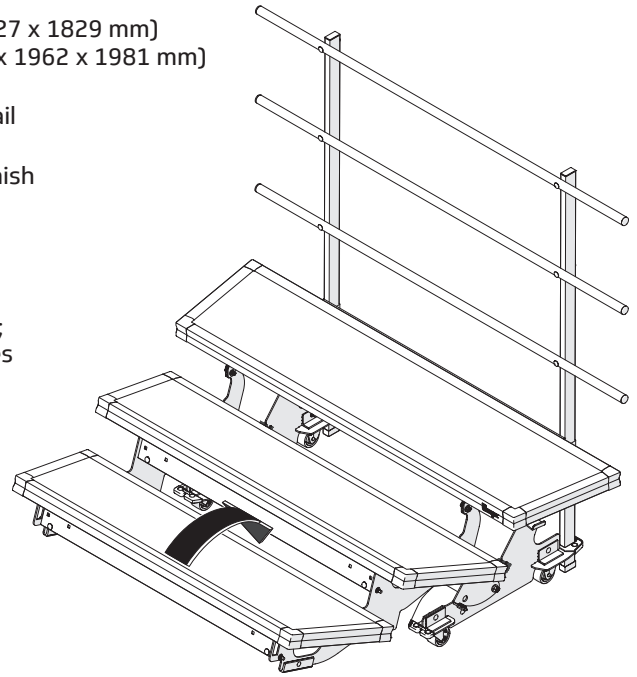

3-Step Riser with Optional Side Rail

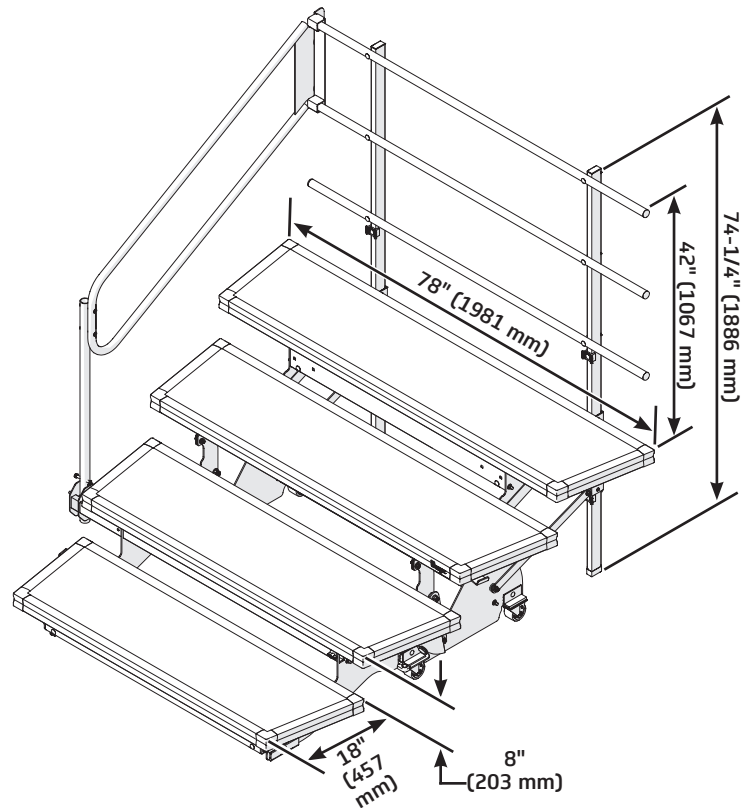

4-Step Riser with Optional Side Rail

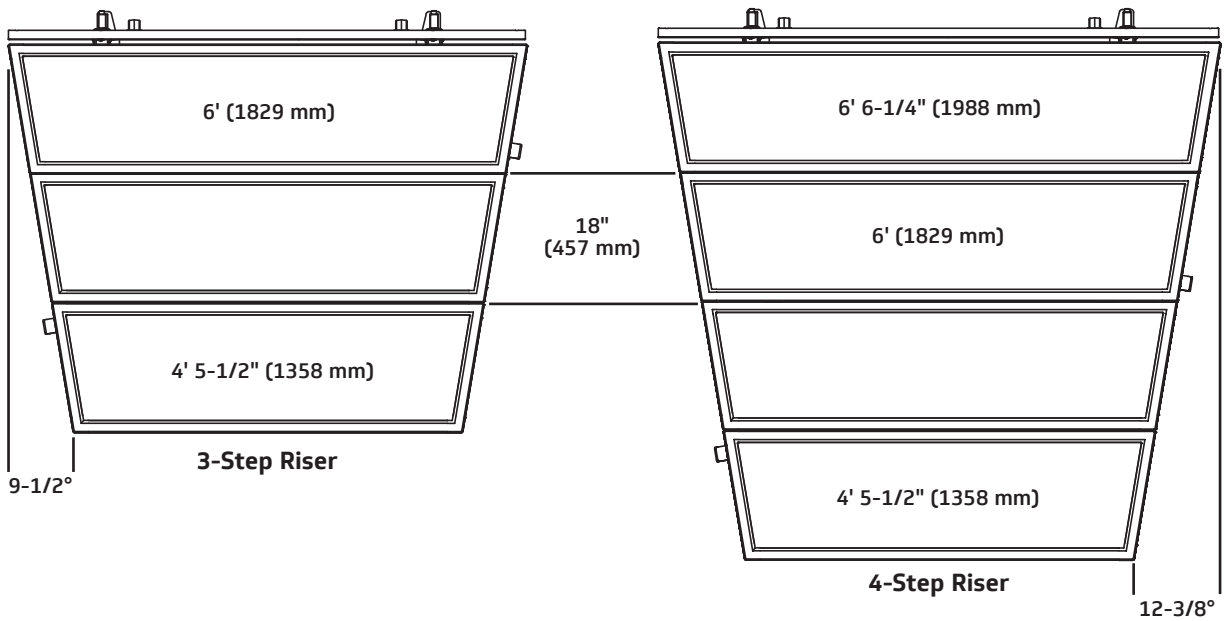

Risers nest together in the storage position, minimizing required storage space.

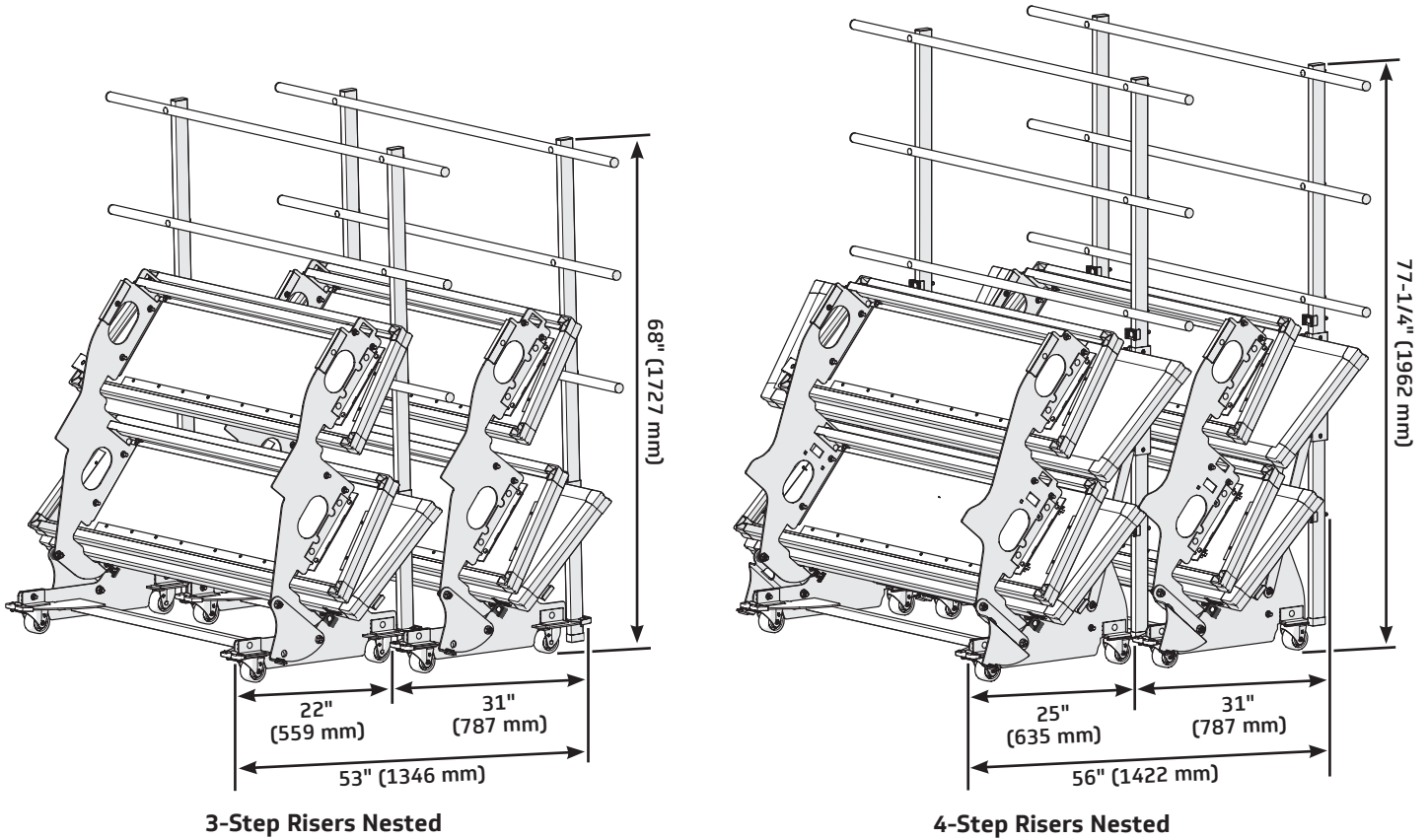

© 2024 Wenger Corporation
USA/2024-04

Minnesota Location

Wenger Phone 800.4WENGER (493-6437) Wenger Worldwide +1.507.455.4100 | Parts & Service 800.887.7145 | wengercorp.com
GearBoss Phone 800.493.6437 | gearboss.com
555 Park Drive, PO Box 448 | Owatonna | MN 55060

New York Location

J.R. Clancy Phone 800.836.1885 JR Clancy Worldwide +1.315.451.3440 | jrclancy.com | 7041 Interstate Island Road | Syracuse | NY 13209

StageTek® Staging System

StageTek is a highly flexible design and can be used to accommodate many unique and custom applications. Please contact your Wenger Representative to discuss your needs.

System Description

- 280A200_ Rectangular decks are available in the following sizes:
 3' x 3' (914 x 914 mm): 37 lb (17 kg)
 3' x 6' (914 x 1829 mm): 65 lb (29 kg)
 3' x 8' (914 x 2438 mm): 87 lb (39 kg)
 4' x 4' (1219 x 1219 mm): 59 lb (27 kg)
 4' x 6' (1219 x 1829 mm): 85 lb (39 kg)
 4' x 8' (1219 x 2438 mm): 107 lb (49 kg)
- Pie shaped and custom decks are available
- Ten-year warranty

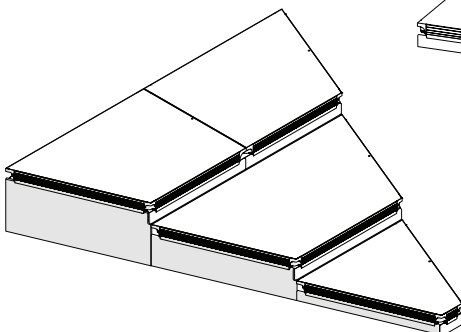
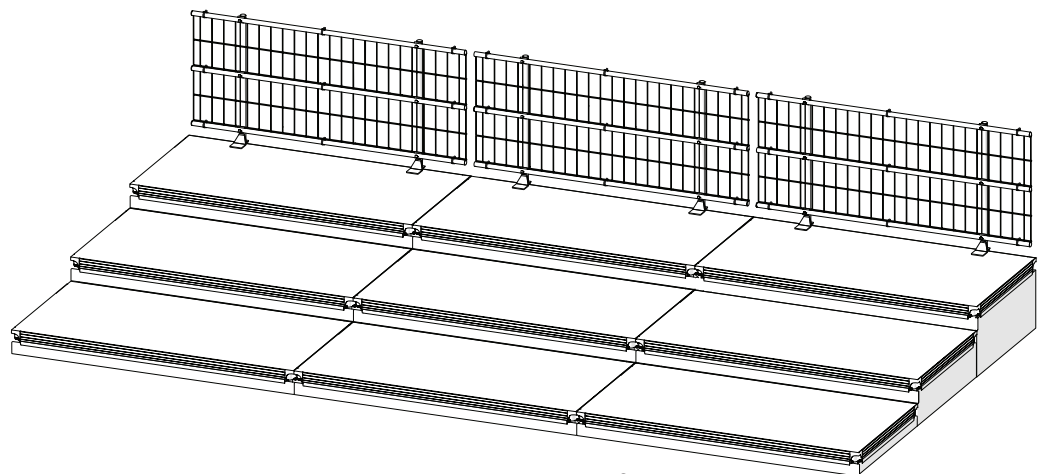
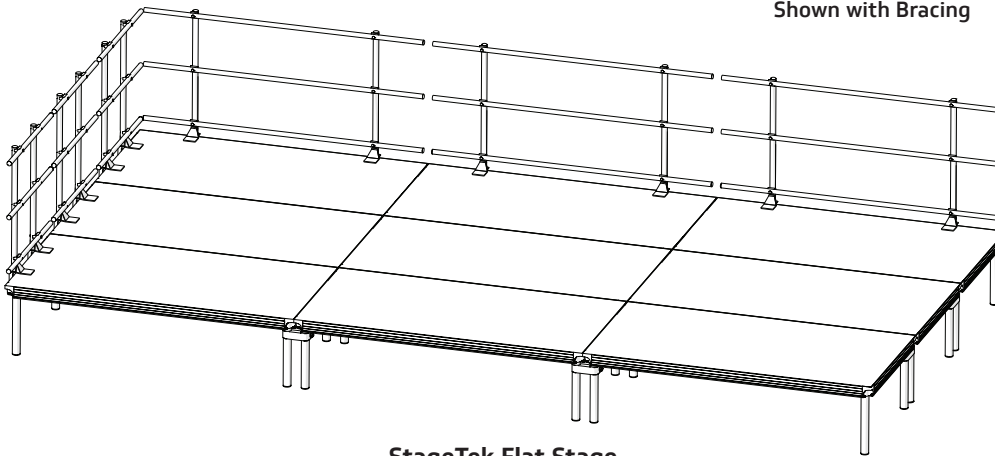
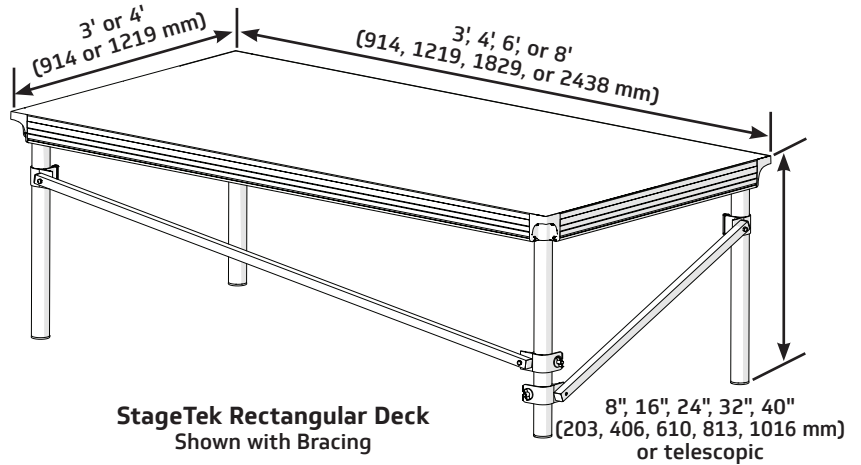

Features

- Platform decks are 3/4" (19 mm) thick and constructed of Group I veneer plywood with a protective laminate on both sides
- Surface options:
 - Black Standard (Cracked Ice Polypropylene): A slip resistant overlay recommended for general multi-purpose
 - Black Versalite-Match (Moroccan): A slip resistant overlay that will match Wenger Versalite decks
 - Black Heavy-Duty (Quadriple): An aggressive textured overlay for applications requiring greater slip resistance
 - Natural or Painted Hardboard: A 1/2" (13 mm) plywood bonded between two faces of 1/8" (3 mm) tempered hard-ply
 - Carpeted: Manufacturer's standard grey carpet over a 5/8" (16 mm) plywood core (contact Wenger for a sample)
 - Carpet Ready: A 5/8" (16 mm) plywood core ready to receive carpet surface
 - Black powder-coat paint finish is available for the deck surface, frame and legs (not telescopic legs)
- Dynamic impact loading: 10,000 cycles of 400 lb-force (181 kg-force) at six locations per 4' x 8' (1219 x 2438 mm) rectangular deck
- StageTek load ratings as measured on a 4' x 8' (1219 x 2438 mm) rectangular deck:
 - Standard uniform live load for decks with 4 legs: 125 lbf/ft² (6 kN/m²), meets L/75 deflection criteria
 - Heavy duty uniform live load for decks with 5th leg (as needed or smaller deck): 150 lbf/ft² (7.2 kN/m²), meets L/180 deflection criteria
 - Heavy duty uniform live load for decks with no 5th leg, added stiffener(s): 150 lbf/ft² (7.2 kN/m²), meets L/180 deflection criteria
 - Lateral live side load: 12 lbf/ft² (0.6 kN/m²) based on deck top surface area, meets IBC code
 - Caster load: 300 lb (136 kg) applied via 2" (51 mm) diameter by 2" (51 mm) wide flat rubber wheel with no appreciable surface deformation
 - Concentrated load: 500 lb (227 mm) on a single 6" x 6" (152 x 152 mm) square area per deck
- Standard rectangular decks feature spaces under each platform unobstructed by folding frames or braces allowing for easy storage/stowage space under the system
- Frame and edging are fabricated from 4" (102 mm) tall aluminum extrusion; extrusion is designed with a slight recess for hook and loop skirting attachment and also features notches hidden on the inside of the frame to accept accessory attachments
- Decks feature fully replaceable components including corners, frame, and wood deck; replaceable in the field with common tools
- An aluminum extrusion center support rail is featured on deck sizes: 4' x 8' (1219 x 2438 mm), 4' x 6' (1219 x 1829 mm) and 3' x 8' (914 x 2438 mm)
- The frame is designed for safer, easier handling and features rounded contours ergonomically sized for a secure power grip (closed grip)
- Standard unit-to-unit connectors are leg-to-leg connections of adjacent decks; additional connectors are available depending on the staging application
- Leg braces are available to provide additional stability

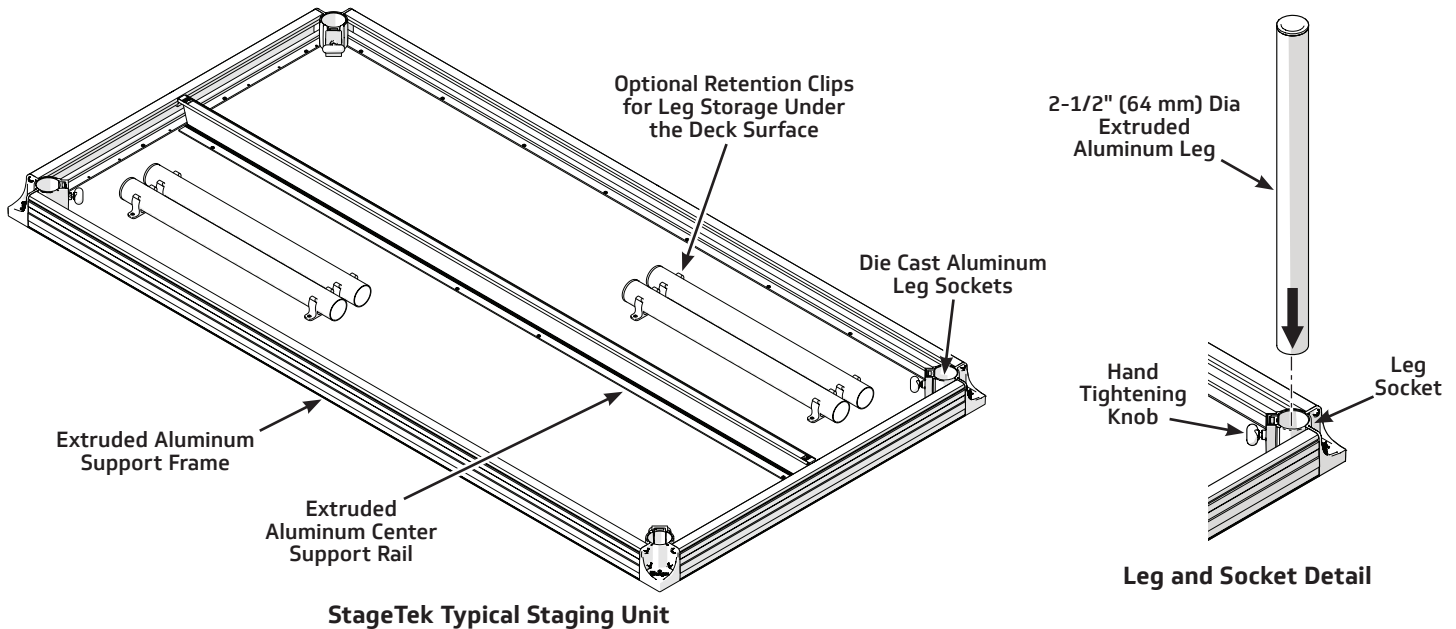

Leg Options

- Available leg options include fixed height, adjustable height and telescopic
- Standard rectangular decks have four die cast aluminum leg sockets; legs are quickly secured without tools by just rotating the knob
- Standard legs are fabricated from 2-1/2" (64 mm) diameter aluminum extrusions and are finished with non-marring cap; available in lengths that result in the following deck heights: 8" (203 mm), 16" (406 mm), 24" (610 mm), 32" (813 mm) and 40" (1016 mm)
- Adjustable telescopic legs feature a threaded leveling foot finished with a rubber pad and non-rattling telescopic adjustment secured with a quick-release pin and jam nut; available in lengths that result in the following deck heights: 16"-28" (406-711 mm), 24"-40" (610-1016 mm) and 30"-54" (762-1372 mm)
- Black powder-coat paint finish is available for fixed height legs and adjustable height legs; not available for telescopic legs
- Custom leg sizes are available

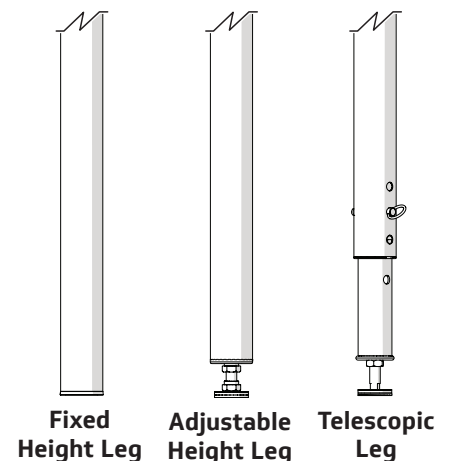

Accessories

Staging Universal Deck & Rail Cart

- 113K001 85 lb (38 kg); fits through a 32" (813 mm) door
- Holds six StageTek rectangular decks (without accessories) or six StageTek guardrails
- Decks and guardrails can be mixed on the same cart
- Ideal for non-rectangular units such as pie shapes used in seated risers and oversize units
- Heavy-duty, non-marring locking casters and ratcheting nylon safety strap

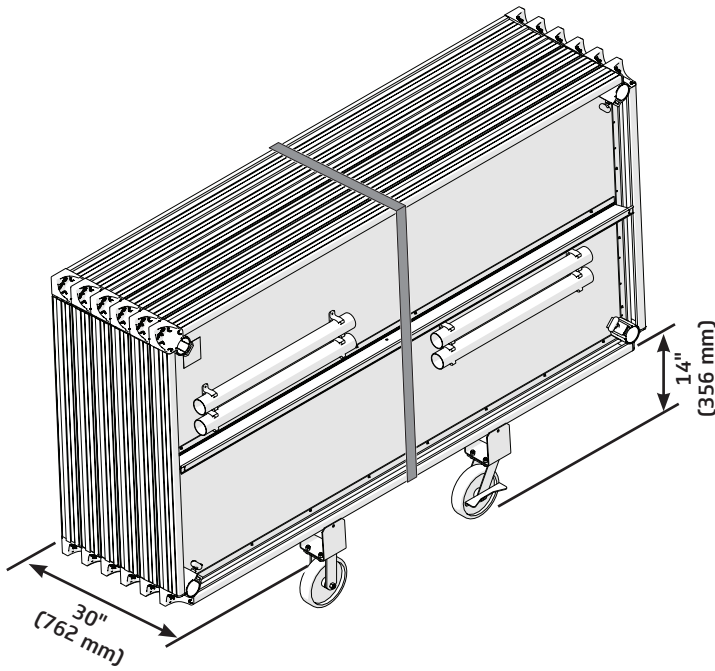

Staging Universal Deck & Rail Cart
Loaded with six Rectangular Decks

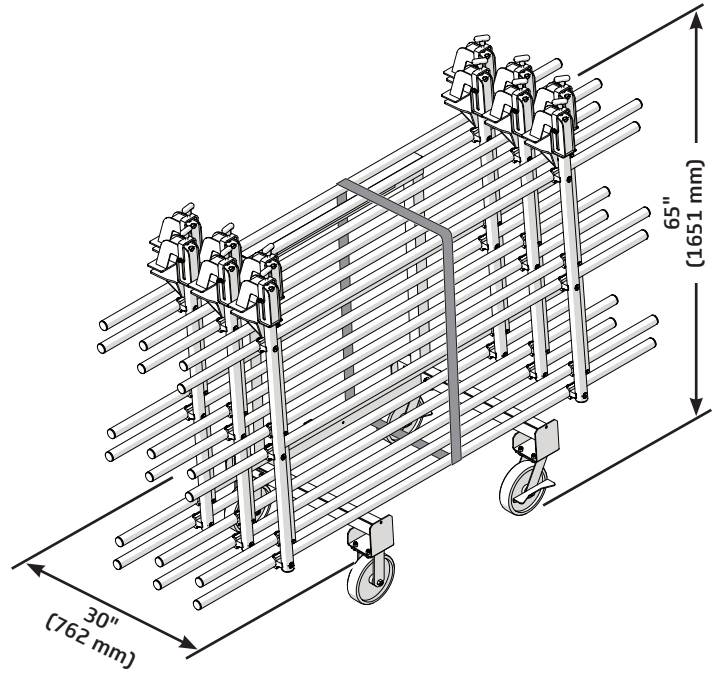

Staging Universal Deck & Rail Cart
Loaded with Six Guardrails

Stairways – Fixed Height and Adjustable

- Adjustable stairways are ideal for custom-height systems and for systems that are frequently set up at different heights
- Stairways feature a hook bracket to function with StageTek decks
- Stairs feature aluminum extruded treads and include permanent handrails on both sides

Fixed Height Stairways	Adjustable Height Stairways
2-Step: 281A100 55 lb (25 kg)	3-Step: 281A201 107 lb (49 kg)
3-Step: 281A101 76 lb (34 kg)	4-Step: 281A202 122 lb (55 kg)
4-Step: 281A102 94 lb (43 kg)	6-Step: 281A203 160 lb (73 kg)
	8-Step: 281A204 188 lb (85 kg)

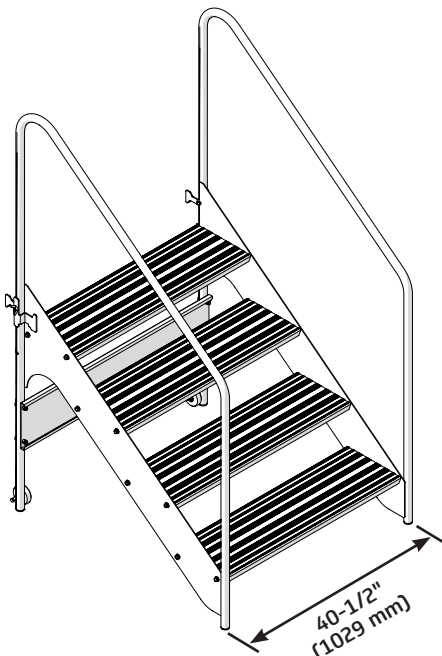

Fixed Height Stairway
4-Step Model

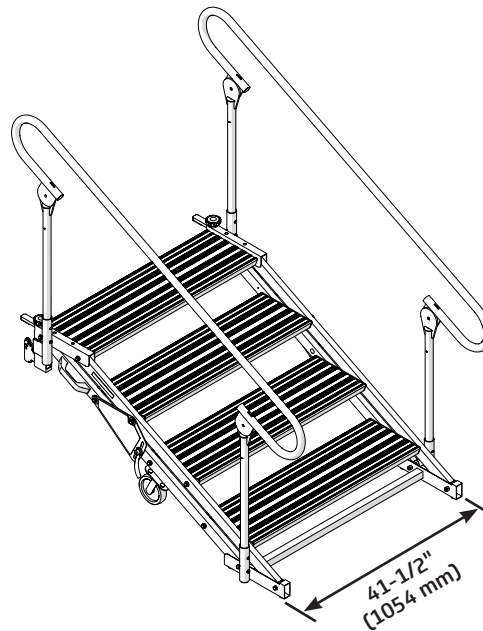

Adjustable Height Stairway
4-Step Model

Accessories (continued)

Guardrails

- Guardrails comply with IBC code requirements for loading
- Guardrails feature two uprights and three cross bars; optional infill panels can be added that comply with the IBC 4" (102 mm) sphere code
- Guardrails can function as a chair stop
- Guardrails are 42" (1067 mm) high with a black powder-coat paint finish
- Guardrails clamp to the stage deck without the need for tools

Clamps, Connectors and Braces

- Optional retention clips for leg storage mount under the deck to provide retained leg storage
- A variety of leg straps, metal leg to leg, leg to deck, overlap and anchor brackets are available
- Stabilizing braces are recommended for heights 40" (1016 mm) and above
- Optional deck-to-deck cam locks are built into the deck frame; cams can be locked or opened via a small tool access hole on top of the platform

Backdrop and Closure Panels

- Drapery is available in heights to match the staging elevation and in a wide variety of colors
- 100% fire retardant woven polyester attaches with hook and loop fastening strips
- Backdrop frame attaches to guardrails and positions a drapery 8' (2438 mm) above the stage; available in 4' (1219 mm), 6' (1829 mm), and 8' (2438 mm) widths
- Solid side and front closures are ideal for seated riser systems
 - Constructed of the same material as the deck with the same surface options
 - Edges are finished in a thermofused black edge band
 - Connects to the rail without tools via an extruded PVC clip running the length of the closure

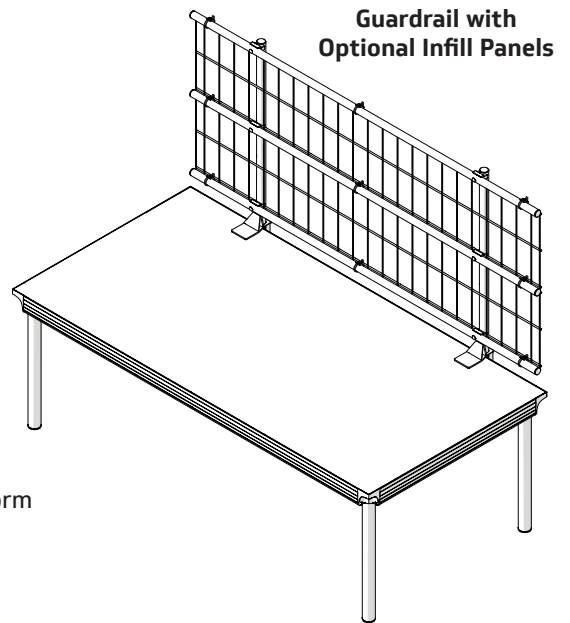

Guardrail with
Optional Infill Panels

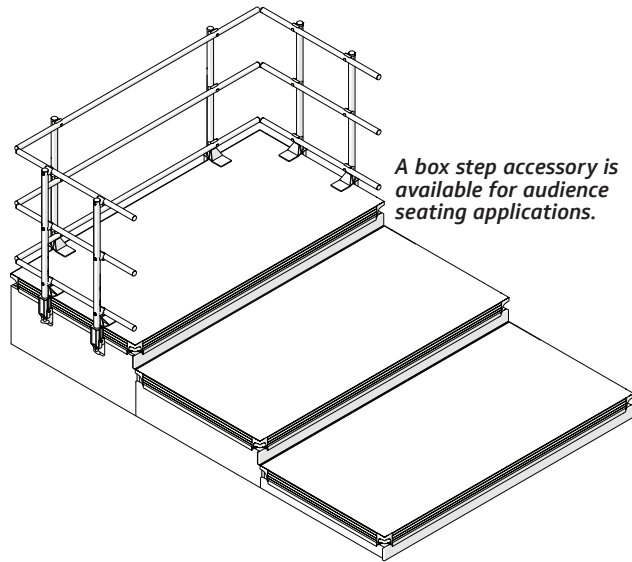

StageTek Seated Riser Configuration
With Guardrails and Closure Panels

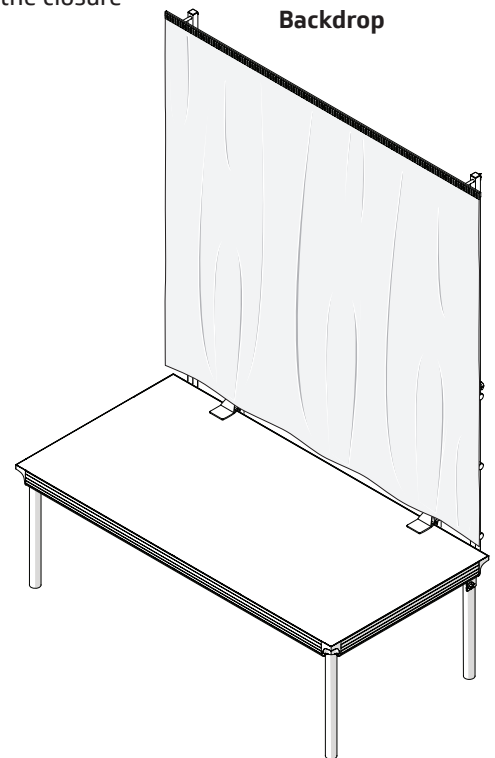

Backdrop

Wenger®

JRCLANCY

GEARBOSS®

© 2025 Wenger Corporation
USA/2025-01

Minnesota Location

Wenger Phone 800.4WENGER (493-6437) Wenger Worldwide +1.507.455.4100 | Parts & Service 800.887.7145 | wengercorp.com

GearBoss Phone 800.493.6437 | gearboss.com

555 Park Drive, PO Box 448 | Owatonna | MN 55060

New York Location

J.R. Clancy Phone 800.836.1885 JR Clancy Worldwide +1.315.451.3440 | jrclancy.com | 7041 Interstate Island Road | Syracuse | NY 13209

Side by Side Pricing

Year	Make	Model	Passengers	Engine Size	Horsepower	Price	Dealer	Price Type	Contact	
2025	Can-Am	Defender DPS HD-7	2	650cc	52	\$14,399.00	Motoplex of Norfolk	Online Price		
2025	Can-Am	Defender DPS HD7	2	650cc	52	\$14,399.00	Yankton Motorsports	Online Price		
2024	Can-Am	Defender Max DPS HD7 (New)	4	650cc	52	\$16,899.00	Big Sioux Powersports of Sioux Falls	Online Price		
2024	Can-Am	Defender XT HD-10 (New)	2	976cc	82	\$16,999.00	Motoplex of Norfolk	Online Price		
2025	Can-Am	Defender DPS HD9	2	976cc	65	\$17,299.00	Big Sioux Powersports of Sioux Falls	Online Price		
2025	Can-Am	Defender DPS HD-10	2	976cc	82	\$17,599.00	Motoplex of Norfolk	Online Price		
2023	John Deere	Gator XUV 590M (New)	2	586cc	32	\$15,210.00	Agrivision of Pender	Quote	Matt Heineman	
2025	John Deere	Gator XUV 845E	2	812cc	53	\$17,010.00	Agrivision of Pender	Quote	Matt Heineman	No Power Steering / Manual Lift Box
2026	John Deere	Gator XUV 845M	2	812cc	53	\$18,970.00	Agrivision of Pender	Quote	Matt Heineman	Power Steering / Manual Lift Box
2026	John Deere	Gator XUV 845M	2	812cc	53	\$20,984.00	Agrivision of Pender	Quote	Matt Heineman	Power Steering / Electric Lift Box
2023	John Deere	Gator XUV 835M (New)	2	812cc	54	\$21,675.00	Agrivision of Pender	Quote	Matt Heineman	
2025	John Deere	Gator XUV 845M	2	812cc	53	\$21,765.00	Agrivision of Pender	Quote	Matt Heineman	Power Steering / Electric Lift Box
2025	Kawasaki	Mule Pro-MX LE	2	695cc	40	\$11,995.00	Verne Eide Motoplex of Sioux Falls	Online Price		
2025	Kawasaki	Mule Pro-MX EPS	2	695cc	40	\$11,999.00	Yankton Motorsports	Online Price		
2024	Kawasaki	Mule Pro TXR 1000 (New)	2	999cc	53	\$14,479.00	B & B Cycle of Norfolk	Online Price		
2025	Kawasaki	Mule Pro-FXT 1000 LE Ranch Edition	3 or 6 Adjustable	999cc	53	\$15,995.00	Verne Eide Motoplex of Sioux Falls	Online Price		
2024	Kubota	Sidekick, RTVXG850WLH24 (New)	2	851cc	54	\$17,855.46	Rush Kubota of West Point	Quote	Maci Johnson	
2025	Polaris	Ranger SP 570	2	567cc	44	\$10,295.00	Verne Eide Motoplex of Sioux Falls	Online Price		
2025	Polaris	Ranger 570	2	567cc	44	\$10,995.00	Taggarts Power Sports of Hinton IA	Online Price		
2025	Polaris	Ranger 1000	2	999cc	61	\$11,995.00	Verne Eide Motoplex of Sioux Falls	Online Price		
2025	Polaris	Ranger SP 570 Premium	2	567cc	44	\$12,295.00	Verne Eide Motoplex of Sioux Falls	Online Price		
2025	Polaris	Ranger SP 570 Premium	2	567cc	44	\$12,499.00	Motoplex of Norfolk	Online Price		
2025	Polaris	Ranger SP 570 Premium	2	567cc	44	\$12,995.00	Taggarts Power Sports of Hinton IA	Online Price		
2025	Polaris	Ranger 1000 Premium	2	999cc	61	\$13,995.00	Verne Eide Motoplex of Sioux Falls	Online Price		
2025	Polaris	Ranger 1000 Premium	2	999cc	61	\$14,995.00	Taggarts Power Sports of Hinton IA	Online Price		

Pender Public Schools Contract Renewal - 3yr

Pender Public Schools

609 Whitney St
 PENDER, NE 68047-5036
 United States

Jennifer Davis

jedavis1@penderschools.org

Reference: 20250612-090144230

Quote created: June 12, 2025

Quote expires: September 10, 2025

Quote created by: Max Magana

Account Manager

max.magana@linewize.com

Comments from Max Magana

Service Dates

08/02/25- 08/01/28

Products & Services

Item & Description	SKU	Quantity	Unit Price	Total
Linewize Monitor - 3 Year Subscription Tier 4 Linewize Monitor - 3 Year Subscription. Student protection software that looks for signs of self harm, school violence, abuse, and other behavior that can be harmful for students. Includes 24x7 hr human monitoring and phone calls for at risk students.	LW-T4-MTR-3Y	400	\$5.00	\$2,000.00 for 3 years
Classwize - 3 Year Subscription Tier 4 Classwize - 3 Year Subscription. Cloud managed classroom management suite. Provides screen visibility and control on Windows, Mac, and Chrome Operating Systems with cloud directory integration and school roster support. Cyber Safety included. 10,000-24,000 FTE	LW-T4-CLASS-3Y	400	\$4.80	\$1,920.00 for 3 years

Item & Description	SKU	Quantity	Unit Price	Total
Advanced SIS 3 Year Subscription Advanced Student Information System (SIS) Integration to pull classroom rosters and associate them with directory users from gsuite or windows environments. 3 Year Subscription. Charged Per Integrated School.	LW-SIS-3Y	2	\$750.00	\$1,500.00 for 3 years
Pulse - 3 YR CUF Tier 1 Linewize Pulse - 3 Year Subscription Tier 3-The Pulse wellbeing platform provides students with a powerful and simple way to give regular updates on their wellbeing and to reach out for support when needed. It empowers Districts to proactively address wellbeing concerns and assess improvements post intervention.	LW-T1-Pulse-3Y-CUF	1	\$17.25	\$17.25 for 3 years
One-time subtotal				\$5,437.25
			Total	\$5,437.25

Purchase terms

Acceptance of this quote confirms your order with us. This order is subject to and you acknowledge that you have been provided with, understand and accept our [Standard Terms](#) , [Data Processing Addendum](#), [Privacy Policy](#) and [Terms of Service & Supply](#).

Standard payment terms are NET 30. Please email purchase orders to orders@linewize.com and make checks payable to Family Zone, Inc. Our products and services are provided in accordance with our standard terms which are available on our website, <https://www.linewize.com>.

Signature

Signature

Date

Printed name

Questions? Contact me



Max Magana
Account Manager
max.magana@linewize.com

Linewize
10803 Thornmint Rd #100
San Diego, CA 92127
United States

Community Relations

Title IX - Discrimination

Pender Public Schools, in response to federal and state regulations for Title IX hereby delegates the Superintendent the authority to develop procedures consistent with Title IX.

Legal Authorities: Title IX

Date of Adoption: April 14, 2008

Date of Amendment: August 18, 2025

StudentsStudent AttendanceAttendance Policy and Excessive Absenteeism

Regular and punctual student attendance is required. The administration is responsible for developing further attendance rules and regulations, and all staff are expected to implement this policy and administrative rules and regulations to encourage regular and punctual student attendance. The District will maintain an accurate record of student attendance.

A. Attendance and Absences.

1. Circumstances of Absences – Definitions. The circumstances for all absences from school will be identified as School Excused or Not School Excused. Absences should be cleared through the Principal's office in advance whenever possible. All absences, except for illness and/or death in the family, require advance approval.
 - a. School Excused. Any of the following circumstances that lead to an absence will be identified as a *School Excused* absence, provided the required attendance procedures have been followed:
 - (1) Impossible or impracticable barriers outside the control of the parent or child prevent a student from attending school. The parent must provide the school with documentation to demonstrate the absence was beyond the control of the parent or child. This could include, but is not limited to documented illness (including physical or mental illness), court, death of a family member, or suspension.
 - (2) Other absences as determined by the principal or the principal's designee.
 - b. Not School Excused. Absences that are not school excused may result in a report to the county attorney and may be classified as follows:
 - (1) Parent acknowledged absences are those in which the parent communicated with the school in the prescribed manner that the child is absent and is the parent's responsibility for the extent of the school day. This includes, but is not limited to, illness, vacations, and medical appointments.
 - (2) Other absences are those in which the parent has not communicated a reason for the student's absence.
2. Absence Procedure. In its Student Information System, the District may identify many different codes that provide greater definition to the circumstances of a

child's absence, but all of the codes need to be identified to parents and students as fitting into one of the above defined absence circumstances.

3. Mandatory Ages of Attendance. A child is of mandatory age if the child will reach age 6 prior to January 1 of the then-current school year and has not reached 18 years of age.

Exceptions for Younger Students. Attendance is not mandatory for a child who has reached 6 years of age prior to January 1 of the then-current school year, but will not reach age 7 prior to January 1 of such school year, if the child's parent or guardian has signed and filed with the school district in which the child resides an affidavit stating either: (1) that the child is participating in an education program that the parent or guardian believes will prepare the child to enter grade one for the following school year; or (2) that the parent or guardian intends for the child to participate in a school which has elected or will elect pursuant to law not to meet accreditation or approval requirements and the parent or guardian intends to provide the Commissioner of Education with a statement pursuant to section 79-1601(3) on or before the child's seventh birthday.

Exceptions for Older Students. Attendance is also not mandatory for a child who: (1) has obtained a high school diploma by meeting statutory graduation requirements; (2) has completed the program of instruction offered by a school which elects pursuant to law not to meet accreditation or approval requirements; or (3) has reached the age of 16 years and has been withdrawn from school in the manner prescribed by law.

Early Withdrawal for Students Enrolled in Accredited or Approved Schools. A person who has legal or actual charge or control of a child who is at least 16 but less than 18 years of age may withdraw such child from school before graduation and be exempt from the mandatory attendance requirements if an exit interview is conducted and a withdrawal form is signed.

Exit Interview. The process is initiated by a person who has legal or actual charge or control of the child submitting a withdrawal form. The form is to be as prescribed by the Commissioner of Education. Upon submission of the form, the Superintendent or Superintendent's designee shall set a time and place for an exit interview if the child is enrolled in Pender Public Schools or resides in the Pender Public School District and is enrolled in a private, denominational, or parochial school.

The exit interview shall be personally attended by:

- The child, unless the withdrawal is being requested due to an illness of the child making attendance at the exit interview impossible or impracticable;
- the person who has legal or actual charge or control of the child who requested the exit interview;

- the Superintendent or Superintendent's designee;
- the child's principal or the principal's designee if the child at the time of the exit interview is enrolled in a school operated by the school district; and
- any other person requested by any of the required parties who agrees to attend the exit interview and is available at the time designated for the exit interview which may include, for example, other school personnel or the child's principal if the child is enrolled in a private school.

At the exit interview, the person making the written request must present evidence that (a) the person has legal or actual charge or control of the child and (b) the child would be withdrawing due to either:

- financial hardships requiring the child to be employed to support the child's family or one or more dependents of the child, or
- an illness of the child making attendance impossible or impracticable.

The Superintendent or Superintendent's designee shall identify all known alternative educational opportunities, including vocational courses of study, that are available to the child in the school district and how withdrawing from school is likely to reduce potential future earnings for the child and increase the likelihood of the child being unemployed in the future. Any other relevant information may be presented and discussed by any of the parties in attendance.

At the conclusion of the exit interview, the person making the written request may sign a withdrawal form provided by the school district agreeing to the withdrawal of the child OR may rescind the written request for the withdrawal.

Withdrawal Form. Any withdrawal form signed by the person making the written request shall be valid only if:

- the child also signs the form, unless the withdrawal is being requested due to an illness of the child making attendance at the exit interview impossible or impracticable, and
- the Superintendent or Superintendent's designee signs the form acknowledging that the interview was held, the required information was provided and discussed at the interview, and, in the opinion of the Superintendent or Superintendent's designee, the person making the written request does in fact have legal or actual charge or control of the child and the child is experiencing either (i) financial hardship, or (ii) an illness making attendance impossible or impracticable.

Early Withdrawal for Students Enrolled in an Exempt School (Home Schools). A person who has legal or actual charge or control of a child who is at least 16 but

less than 18 years of age may withdraw such child from school before graduation and be exempt from the mandatory attendance requirements if such child has been enrolled in a school that elects not to meet the accreditation or approval requirements by filing with the State Department of Education a signed notarized release on a form prescribed by the Commissioner of Education.

4. Reporting and Responding to Excessive Absenteeism. Any administrator, teacher, or member of the board of education who knows of any failure on the part of any child of mandatory school attendance age to attend school regularly without lawful reason, shall within three days report such violation to the superintendent or such person(s) who the superintendent designates to be the attendance officer (hereafter, "attendance officer"). The attendance officer shall immediately cause an investigation into any such report to be made. The attendance officer shall also investigate any case when of his or her personal knowledge, or by report or complaint from any resident of the district, the attendance officer believes there is a violation of the compulsory attendance laws. The school shall render all services in its power to compel such child to attend some public, private, denominational, or parochial school, which the person having control of the child shall designate, in an attempt to address the problem of excessive absenteeism. Such services shall include, as appropriate, the services listed below under "Excessive Absenteeism" and "Reporting Excessive Absenteeism."
5. Excessive Absenteeism. Students who accumulate ten (10) not school excused absences in a semester shall be deemed to have "excessive absences." Such absences shall be determined on a per day basis for elementary students and on a per class basis for secondary students. When a student has excessive absences, school officials will have verbal or written communication with the person or persons who have legal or actual charge or control of any child.

When a student continues thereafter to have absences of at least twenty days which are Not School Excused, one or more meetings between the school, the child's parent or guardian, and the child, when appropriate, to address the barriers to attendance. The result of the meeting or meetings shall be to develop a collaborative plan to reduce barriers identified to improve regular attendance. The plan shall include, if agreed to by the person who is responsible for making educational decisions on behalf of the child, an educational evaluation to determine whether any intellectual, academic, physical, or social-emotional barriers are contributing factors to the lack of attendance. The plan shall also consider, but not be limited to:

- (a) The physical, mental, or behavioral health of the child.
- (b) Educational counseling;
- (c) Referral to community agencies for economic services;
- (d) Family or individual counseling; and
- (e) Assisting the family in working with other community services.

If the parent/guardian refuses to participate in such meeting, the principal shall place documentation of such refusal in the child's attendance records.

6. Reporting Excessive Absenteeism to the County Attorney.

The school may report to the county attorney of the county in which the person resides when the school has documented the efforts to address excessive absences, the collaborative plan to reduce barriers identified to improve regular attendance has not been successful, and the student has accumulated more than twenty (20) absences per school year. The school shall notify the child's family in writing prior to referring the child to the county attorney. Illness (including physical or mental illness) that makes attendance impossible or impracticable shall not be the basis for referral to the county attorney. A report to the county attorney may also be made when a student otherwise accrues excessive absences as herein defined.

Legal Reference: Neb. Rev. Stat. " 79-201 and 79-209

Date of Adoption: July 9, 2012
Date of Amendment: September 9, 2013
Date of Amendment: July 14, 2014
Date of Amendment: August 8, 2016
Date of Amendment: November 9, 2020
Date of Amendment: August 21, 2023
Date of Amendment: June 10, 2024
Date of Amendment: August 18, 2025

StudentsGrading System

The grading system of Pender Public Schools shall be as follows:

a. Grading periods of approximately nine (9) weeks shall be used four (4) times per year in the elementary. Grading periods of approximately eighteen (18) weeks, 1 semester, shall be used two (2) times per year in the secondary.

b. Achievement marks shall be given on a numerical basis for all grades 7-12, with the marks of below 70 considered a failure.

c. The secondary (7-12 grade) students grading and conversion scale are as follows:

A+98-100; 4.0	B+ 91-92.99; 3.7	C+ 84-85.99; 2.7	D+ 76-77.99; 1.7	F Below 70
A 95-97.99; 4.0	B 89-90.99; 3.3	C 82-83.99; 2.3	D 73-75.99; 1.3	
A-93-94.99; 4.0	B- 86-88.99; 3.0	C- 78-81.99; 2.0	D- 70-72.99; 1.0	

d. Class rank grade calculation will be determined by averaging points each semester after the final grade for a class is figured by the teacher. "Weighing" certain high-level and/or college credit classes may take place. "Weight" will be added to these classes by adding 3.5 percentage points each semester after the grade average is figured. Weighted classes are Calculus, Advanced Biology, Chemistry, Human Anatomy and Physiology, Physics, College Prep English, College Trigonometry, Statistics and Dual Credit Courses on a case by case basis.

e. ***Honor Roll: The students in grades 7-12 will have an academic honor roll for those who excel in the classroom. The honor roll shall consist of the following three criteria:***

1. ***Principal's Honor Roll (98-100%)***
2. ***Scholastic Honor Roll (94-97.99%)***
3. ***Merit Honor Roll (90-93.99%)***

Averages will not be rounded.

f. The elementary (K-6 grade) students grading scales for all content areas are as follows:

- 4 – Exceeds – Independently performs above grade-level expectations
- 3 – Meets – Demonstrates grade-level skills, little or no support needed
- 2 – Progressing – Skills are developing, some support needed
- 1 – Beginning – Skills are limited, frequent support needed

Within each content area, teachers will assess student knowledge and assign one of the proficiency ratings above to each graded standard. Each content area has several graded standards based on standards dictated by the Nebraska Department of Education. The

proficiency rating assigned will be based on student performance over the course of the grading period on practice work, formative assessment, and summative assessment. Emphasis will be placed on the most consistent level of work and knowledge as well as the most recent level of work and knowledge. Life skills and student conduct are separately graded for each student.

- g. **Honor Roll:** The purpose of the elementary honor roll is to recognize those students who demonstrate academic excellence. Honor rolls will be determined for 1st, 2nd, 3rd and 4th quarters. Students will be recognized accordingly:
1. Students receiving all "3's" and "4's" on their report card will be classified as honor roll students.
 2. Students in grades 4-6 are honor roll eligible.
 3. Honor roll lists are published in school and community publications.
- h. For all other grading reports received on transfer students, the Superintendent and/or principal shall convert these to an approximately equal grade on our system.
- i. Staff members may use whatever method they determine professionally appropriate in the day-to-day grading, but shall prepare grade reports based on numerical values. Each staff member, however, must be able to defend whatever method chosen. The following criteria should be used in determining the numerical value of the grade.
1. Achievement in relation to class objectives.
 2. Class participation.
 3. Mental ability of student in relation to the total class and required work.
 4. Evidence the student is exceeding the class requirements and delving further.
- j. All grade reports will contain the numerical grade for each subject, as well as the following: absences, tardiness, department, comments (if instructor desires).
- k. See Policy 5207 regarding make up work.

Date of Adoption: December 10, 2007

Date of Amendment: August 11, 2014

Date of Amendment: December 13, 2017

Date of Amendment: August 18, 2025

StudentsGraduation

To participate in commencement exercises or receive a Pender Public Schools diploma a student must fully complete all requirements for graduation prior to the official commencement exercises, and complete other administrative requirements or conditions. Students who graduate from Pender Public Schools must accumulate 225 credit hours. A student must have at least 170 core curriculum hours. The total graduation requirements must include the following core curriculum:

Language Arts – 45 credit hours

Must include an English class at each grade level.

Must include Speech – 5 credit hours

Science – 30 credit hours

Biology – 10 credit hours

Physical Science – 10 credit hours

Physics, Chemistry or Applied Physics – 10 credit hours

Mathematics – 30 credit hours

Must include Algebra I, Geometry, Algebra II or higher level math.

Career and Technical Education – 10 credit hours

Must include Personal Finance – 5 credit hours

Social Sciences – 40 credit hours

Geography – 10 credit hours

World History – 10 credit hours

American History – 10 credit hours

American Government – 5 credit hours

Economics – 5 credit hours

Physical Education – 10 credit hours

Health – 5 credit hours (required)

Physical Education – 5 credit hours

Fine Arts – 5 credit hours

Intro to Computer Science & Technology - 5 credit hours

Each student shall also complete and submit a Free Application for Federal Student Aid prior to graduation, unless the required opt-out form is completed by either: (1) the student's parent or legal guardian; (2) the Principal, if the Principal determines that good cause exists not to require the student to complete the FAFSA; or (3) an emancipated student or student of at least 19 years of age.

Students who are under an Individualized Education Plan (IEP) may participate in commencement exercises.

See Board of Education Policy 5242 "Requirements for Graduation" for more information.

Date of Adoption: July 25, 2007
Date of Amendment: May 9, 2016
Date of Amendment: June 10, 2024
Date of Amendment: August 18, 2025

StudentsMake-up Work

Make-up work for students who are absent from school shall be governed by guidelines developed by the Superintendent or Superintendent's designee. The Guidelines shall state the criteria to be used in determining whether and to what extent the opportunity to complete class work, including examinations, missed during a period of disciplinary suspension will be granted.

The make-up work of students will be counted for course credit when satisfactorily completed according to the guidelines stated below; which are the Superintendent's guidelines, or such other guidelines as approved from time to time by the Superintendent or the Superintendent's designee.

To receive credit for work missed due to excused absences (e.g., personal illness, bereavement or emergency in the family, participation in an approved school activity), the student, upon returning to school, is responsible a) for requesting assignments for make-up work and b) for completing the make-up work on his/her own initiative by the due date. The teacher will provide materials and assistance to a student who is making up work for these reasons.

To receive credit for work missed due to a parent requested prearranged absence (e.g., medical or dental appointment, religious observance, spectator at a school activity, family trip, college visit), the student is responsible a) for requesting assignments for make-up work prior to his/her absence and b) for completing the make-up work on his/her own initiative by the due date.

For students, the date when make-up work is due at the end of the unit of study, which will be determined by the teacher.

Students who plan to miss school due to scheduled school activity or a parent requested prearranged absence may request assignments and make arrangements to complete part of all of the work prior to the absence.

At the beginning of each semester, or during the semester for students who enter during the semester, a) the principal will provide students with information about the district regulations for absences and make-up work and b) teachers will explain the procedures students should use for requesting assignments and completing make-up work in their courses.

Students and parents/guardians are advised that equivalent experiences for students who miss class are difficult and sometimes impossible to recreate. Parents/guardians are also advised that testing and summarizing activities often are scheduled at the end of the quarter and the end of the semester; parent requested prearranged absences should be avoided during these times.

Date of Adoption: August 13, 2007

Date of Amendment: September 9, 2013

Date of Amendment: August 18, 2025

RESOLUTION

WHEREAS, the School Board is required by law to adopt by resolution policies and specific standards for acceptance or rejection of option enrollment applications by October 15th for the following school year; and,

WHEREAS, the School Board has received and reviewed evidence and information submitted by the administration and other sources and made determinations thereon with respect to standards for acceptance or rejection and with respect to the capacity of this school district to accept option enrollment students based upon available staff, available facilities, projected enrollment, and availability of special education programs for the following school year; and,

WHEREAS, the School Board has determined that the educational interests of this school district would be best served by adoption of the resolutions, and the policies and specific standards herein contained.

NOW, THEREFORE, BE IT RESOLVED that the Option Enrollment Policy presented to the School Board as Administrative Regulation (AR) 5006.1, should be and the same are hereby adopted, and any previous policy or interpretation or application of the option enrollment program which is or has been inconsistent with the Policy 5006, and AR 5006.1 to such Policy 5006, are repealed effective on the date of the passage of this resolution,

BE IT FURTHER RESOLVED that all paragraphs, subparagraphs, and portions of words of this Resolution, of Policy 5006, and AR 5006.1 to such Policy 5006 are severable and that in the event any of the same are determined to be invalid for any reason, such determination shall not affect the validity of any of the remainder of the same.

BE IT FURTHER RESOLVED that policies and specific standards for acceptance or rejection of option enrollment applications should be and are hereby adopted, for applications filed after adoption of this resolution, and are hereinafter set forth:

The above Resolution, having been read in its entirety, member _____ moved for its passage and adoption, member _____ seconded the same. After discussion and on roll call vote, the following members voted in favor of passage and adoption of the above Resolution:

The following members voted against the same: _____.

The following members were absent or not voting: _____.

The Resolution having been consented to and approved by more than a majority of the members of the School Board, was declared as passed and adopted by the President at a duly held and lawfully convened meeting in full compliance with the Nebraska open meetings law.

DATED this 18th day of August, 2025.

PENDER PUBLIC SCHOOLS

Attest By: _____
President Secretary

AR 5006.1 to Option Enrollment Policy

The following is AR 5006.1 to Policy 5006 for the 2025-2026 School Year. The Board of Education hereby sets forth the maximum number of option students for the 2025-2026 school year in any program, class, grade level or school building or in any special education programs operated by this school district, based upon available staff, facilities, projected enrollment of resident students, projected number of students with which this school district will contract based on existing contractual arrangements, and availability of appropriate special education programs. Any program, class, grade level, or school building which has “0” as the No. of Option Students is hereby declared unavailable to option students due to lack of capacity.

PROGRAM	PROGRAM CAPACITY	PROJECTED ENROLLMENT	NO. OF OPTION STUDENTS
Kindergarten	40	31	9
First	40	33	7
Second	40	29	11
Third	40	30	10
Fourth	40	24	16
Fifth	40	24	16
Sixth	40	40	0
Building Capacity, Elementary	280	211	69
Seventh	40	34	6
Eighth	40	31	9
Ninth	40	34	6
Tenth	40	32	8
Eleventh	40	41	0
Twelfth	40	28	12
Building Capacity, Jr./Sr. High School Attendance Center	240	200	40

- Special Education capacity will be determined on a case-by-case basis in accordance with State Law and the available resources as determined by the District’s Director of Special Education or designee.

Administrative Regulation Approved: August 18, 2025

StudentsAnti-Bullying Policy

One of the missions of the District is to provide a physically safe and emotionally secure environment for students and staff.

The administration and staff are to implement strategies and practices to reinforce and encourage positive behaviors by students. Positive behaviors include non-violence, cooperation, teamwork, understanding, and acceptance of others.

The administration and staff are to implement strategies and practices to identify and prevent inappropriate behaviors by all students, including anti-bullying education for all students. Inappropriate behaviors include bullying, intimidation, and harassment. Bullying means any ongoing pattern of physical, verbal, or electronic abuse on school grounds, in a vehicle owned, leased, or contracted by the school being used for a school purpose by a school employee or designee, or at school-sponsored activities or school-sponsored athletic events.

The school district shall review the anti-bullying policy annually.

Legal Reference: Laws 2008, LB 205
 Student Discipline Act, Neb. Rev. Stat. ' ' 79-254 to 79-296
 NDE February 2003 State Board Action; Reaffirmed December 2005

Date of Adoption: August 18, 2008

STUDENT FEES POLICY

The Board of Education of Pender Public Schools adopts the following student fees policy in accordance with the Public Elementary and Secondary Student Fee Authorization Act.

The District's general policy is to provide for the free instruction in school in accordance with the Nebraska Constitution and state and federal law. This generally means that the District's policy is to provide free instruction for courses which are required by state law or regulation and to provide the staff, facility, equipment, and materials necessary for such instruction, without charge or fee to the students.

The District does provide activities, programs, and services to children which extend beyond the minimum level of constitutionally required free instruction. Students and their parents have historically contributed to the District's efforts to provide such activities, programs, and services. The District's general policy is to continue to encourage and, to the extent permitted by law, to require such student and parent contributions to enhance the educational program provided by the District.

Under the Public Elementary and Secondary Student Fee Authorization Act, the District is required to set forth in a policy its guidelines or policies for specific categories of student fees. The District does so by setting forth the following guidelines and policies. This policy is subject to further interpretation or guidance by administrative or Board regulations which may be adopted from time to time. The Policy includes Appendix "1," which provides further specifics of student fees and materials required of students. Parents, guardians, and students are encouraged to contact their building administration or their teachers or activity coaches and sponsors for further specifics.

(1) Guidelines for non-specialized attire required for specified courses and activities. Students have the responsibility to furnish and wear nonspecialized attire meeting general District grooming and attire guidelines, as well as grooming and attire guidelines established for the building or programs attended by the students or in which the students participate. Students also have the responsibility to furnish and wear nonspecialized attire reasonably related to the programs, courses and activities in which the students participate where the required attire is specified in writing by the administrator or teacher responsible for the program, course or activity.

The District will provide or make available to students such safety equipment and attire as may be required by law, specifically including appropriate industrial-quality eye protective devices for courses of instruction in vocational, technical, industrial arts, chemical or chemical-physical classes which involve exposure to hot molten metals or other molten materials, milling, sawing, turning, shaping, cutting, grinding, or stamping of any solid materials, heat treatment, tempering, or kiln firing of any metal or other materials, gas or electric arc welding or other forms of welding processes, repair or servicing of any vehicle, or caustic or explosive materials, or for laboratory classes involving caustic or explosive materials, hot liquids or solids, injurious radiations, or other similar hazards. Building administrators are directed to assure that such equipment is available in the appropriate classes and areas of the school buildings, teachers are directed to instruct students in the

usage of such devices and to assure that students use the devices as required, and students have the responsibility to follow such instructions and use the devices as instructed.

(2) Personal or consumable items & miscellaneous

(a) Extracurricular Activities. Students have the responsibility to furnish any personal or consumable items for participation in extracurricular activities.

(b) Courses

(i) General Course Materials. Items necessary for students to benefit from courses will be made available by the District for the use of students during the school day. Students may be encouraged, but not required, to bring items needed to benefit from courses including, but not limited to, pencils, paper, pens, erasers, notebooks, trappers, protractors and math calculators. A specific class supply list will be published annually in a Board-approved student handbook or supplement or other notice. The list may include refundable damage or loss deposits required for usage of certain District property.

(ii) Damaged or Lost Items. Students are responsible for the careful and appropriate use of school property. Students and their parents or guardian will be held responsible for damages to school property where such damage is caused or aided by the student and will also be held responsible for the reasonable replacement cost of school property which is placed in the care of and lost by the student.

(iii) Materials Required for Course Materials. Students are permitted to and may be encouraged to supply materials for course projects. Some course projects (such as projects in art and shop classes) may be kept by the student upon completion. In the event the completed project has more than minimal value, the student may be required, as a condition of the student keeping the completed project, to reimburse the District for the reasonable value of the materials used in the project. Standard project materials will be made available by the District. If a student wants to create a project other than the standard course project, or to use materials other than standard project materials, the student will be responsible for furnishing or paying the reasonable cost of any such materials for the project.

(iv) Music Course Materials. Students will be required to furnish musical instruments for participation in optional music courses. Use of a musical instrument without charge is available under the District's fee waiver policy. The District is not required to provide for the use of a particular type of musical instrument for any student.

(v) Parking. Students may be required to pay for parking on school grounds or at school-sponsored activities, and may be subject payment of fines or damages for damages caused with or to vehicles or for failure to comply with school parking rules.

(3) Extracurricular Activities-Specialized equipment or attire. Extracurricular activities means student activities or organizations which are supervised or administered by the District, which do not count toward graduation or advancement between grades, and in which participation is not otherwise required by the District. The District will generally furnish students with specialized equipment and attire for participation in extracurricular

activities. The District is not required to provide for the use of any particular type of equipment or attire. Equipment or attire fitted for the student and which the student generally wears exclusively, such as dance squad, cheerleading, and music/dance activity (e.g. choir or show choir) uniforms and outfits, along with T-shirts for teams or band members, will be required to be provided by the participating student. The cost of maintaining any equipment or attire, including uniforms, which the student purchases or uses exclusively, shall be the responsibility of the participating student. Equipment which is ordinarily exclusively used by an individual student participant throughout the year, such as golf clubs, softball gloves, and the like, are required to be provided by the student participant. Items for the personal medical use or enhancement of the student (braces, mouth pieces, and the like) are the responsibility of the student participant. Students have the responsibility to furnish personal or consumable equipment or attire for participation in extra curricular activities or for paying a reasonable usage cost for such equipment or attire. For musical extracurricular activities, students may be required to provide specialized equipment, such as musical instruments, or specialized attire, or for paying a reasonable usage cost for such equipment or attire.

(4) Extracurricular Activities-Fees for participation. Any fees for participation in extracurricular activities are further specified in Appendix "1." Admission fees are charged for extracurricular activities and events.

(5) Postsecondary education costs. Students are responsible for postsecondary education costs. The phrase "postsecondary education costs" means tuition and other fees only associated with obtaining credit from a postsecondary educational institution. For a course in which students receive high school credit and for which the student may also receive postsecondary education credit, the course shall be offered without charge for tuition, transportation, books, or other fees, except tuition and other fees associated with obtaining credits from a postsecondary educational institution.

(6) Transportation costs. Students are responsible for fees established for transportation services provided by the District as and to the extent permitted by federal and state laws and regulations.

(7) Copies of student files or records. The Superintendent or the Superintendent's designee shall establish a schedule of fees representing a reasonable cost of reproduction for copies of a student's files or records for the parents or guardians of such student. A parent, guardian or student who requests copies of files or records shall be responsible for the cost of copies reproduced in accordance with such fee schedule. The imposition of a fee shall not be used to prevent parents of students from exercising their right to inspect and review the students' files or records and no fee shall be charged to search for or retrieve any student's files or records. The fee schedule shall permit one copy of the requested records be provided for or on behalf of the student without charge and shall allow duplicate copies to be provided without charge to the extent required by federal or state laws or regulations.

(8) Participation in before-and-after-school or prekindergarten services. Students are responsible for fees required for participation in before-and-after-school or prekindergarten services offered by the District, except to the extent such services are required to be provided without cost.

(9) Participation in summer school or night school. Students are responsible for fees required for participation in summer school or night school. Students are also responsible for correspondence courses.

(10) Breakfast and lunch programs. Students shall be responsible for items which students purchase from the District's breakfast and lunch programs. The cost of items to be sold to students shall be consistent with applicable federal and state laws and regulations. Students are also responsible for the cost of food, beverages, and personal or consumable

items which the students purchase from the District or at school, whether from a "school store," a vending machine, a booster club or parent group sale, a book order club, or the like. Students may be required to bring money or food for field trip lunches and similar activities.

(11) Waiver Policy. The District's policy is to provide fee waivers in accordance with the Public Elementary and Secondary Student Fee Authorization Act. Students who qualify for free or reduced-price lunches under United States Department of Agriculture child nutrition programs shall be provided a fee waiver or be provided the necessary materials or equipment without charge for: (1) participation in extracurricular activities and (2) use of a musical instrument in optional music courses that are not extracurricular activities. Participation in a free-lunch program or reduced-price lunch program is not required to qualify for free or reduced price lunches for purposes of this section. Students or their parents must request a fee waiver prior to participating in or attending the activity, and prior to purchase of the materials.

(12) Distribution of Policy. The Superintendent or the Superintendent's designee shall publish the District's student fee policy in the Student Handbook or the equivalent (for example, publication may be made in an addendum or a supplement to the student handbook). The Student Handbook or the equivalent shall be provided to every student of the District or to every household in which at least one student resides, at no cost.

(13) Student Fee Fund. The School Board hereby establishes a Student Fee Fund. The Student Fee Fund shall be a separate school district fund not funded by tax revenue, into which all money collected from students and subject to the Student Fee Fund shall be deposited and from which money shall be expended for the purposes for which it was collected from students. Funds subject to the Student Fee Fund consist of money collected from students for: (1) participation in extracurricular activities, (2) postsecondary education costs, and (3) summer school or night school.

CERTIFICATION

On the 19th day of August, 2024, the school board held a public hearing at a meeting of the school board on a proposed student fee policy. Such public hearing followed a review of the amount of money collected from students pursuant to, and the use of waivers provided in, the student fee policy for the preceding school year. The foregoing student fee policy was adopted after such public hearing by a majority vote of the school board at an open public meeting in compliance with the public meetings in compliance with the public meetings laws.

Superintendent or Other Authorized School Official

Legal References:

- Neb. Rev. Stat. §§79-2,125 to 79-2,135 and Laws 2003, LB 249 (The Public Elementary and Secondary Student Fee Authorization Act)
- Neb. Constitution, Article VII, section 1.
- Neb. Rev. Stat. §§79-241, 79-605, and 79-611(transportation)
- Neb. Rev. Stat. §79-2,104 (student files or records)
- Neb. Rev. Stat. §79-715 (eye-protective devices)
- Neb. Rev. Stat. §79-737 (liability of students for damages to school books)
- Neb. Rev. Stat. §79-1104 (before-and-after-school or prekindergarten services)
- Neb. Rev. Stat. §§79-1106 to 79-1108.03 (accelerated or differentiated curriculum)

program)

Date of Adoption: August 13, 2007

Date of Amendment: January 15, 2018

**Appendix "1" to Student Fees Policy of
Pender Public Schools
For the 2025-2026 School Year**

Additional Specification of Required Materials and Fees¹

Program	General Description of Fee or Material	\$ Amount of Fee (Anticipated or Maximum)² or Specific Material Required
Elementary Program		
Physical Education classes	Appropriate clothing (non-specialized attire)	Gym specific shoes and socks, athletic shorts, T-shirt
Art classes and special projects or events	Appropriate clothing (non-specialized attire)	Shirt for painting; other clothing which may get paint on it or otherwise be damaged
Music-Optional band Courses	Musical instruments	Musical instruments and accessories (reeds, valve oil, drum sticks, lyres, flip folders, slide grease, reed guards, cleaning swabs, mouthpiece brushes, pad savers, ligatures, and a "gig bag", etc.) Limited instruments available for student use.
Classroom supplies	General supplies, such as writing instruments (pens, pencils, crayons, markers), notebooks, etc.	None--necessary classroom supplies will be made available by the school. Students will be responsible for the replacement cost of damaged or lost supplies. Students are encouraged but not required to bring items from class supply lists

¹ This listing is a part of the Student Fees Policy and is intended to provide supplemental information. For additional specifications, refer to the Policy.

² Generally, dollar amounts are stated in terms of "maximums." The actual fee or charge may be less during the school year.

Field Trips	Transportation and admission costs of field trips	None-Costs of school sponsored, class-related field trips will be paid for by the school. School lunches may be provided as needed for students.
Summer school courses	Classes offered during the summer, or at night	\$0 to \$350 per class.
Copies	Use of school copiers (except for one copy of the student file, which will be provided without charge).	Ten cents (.10) per page for black/white and twenty-five cents (.25) per page for color when charges apply.
School Meals	Price is based on one meal per day, will vary depending on the number of meals or items purchased by the student, and may be adjusted during the year.	P-12 Breakfast--\$2.45 Lunch—Preschool \$2.85 K-6 - \$3.10 7-12 - \$3.35 Milk -\$.55 Seconds: Main - \$1.65 Side - \$1.45 Milk - \$0.55
Secondary Program	General Description of Fee or Material	\$ Amount of Fee (Anticipated or Maximum) or Specific Material Required
Physical Education classes	Appropriate clothing (non-specialized attire)	Gym specific shoes and socks, athletic shorts, T-shirt
Art and shop classes and special projects, science classes	Appropriate clothing (non-specialized attire) Goggles-1 pair provided per year. If lost or damaged students are required to purchase a new pair.	Shirt for painting; other clothing which may get paint on it or otherwise be damaged; protective clothing for shop classes; approved protective goggles for science classes.

Music-Optional band courses	Musical instruments	Musical instruments and accessories (reeds, valve oil, etc.) Limited instruments available for student use.
Classroom Supplies	General supplies, such as writing instruments (pens, pencils, crayons, markers), notebooks, etc.	None--necessary classroom supplies will be made available by the school. Students will be responsible for the replacement cost of damaged or lost supplies. Students are encouraged but not required to bring items from class supply lists which may be handed out by the office or individual teachers.
Classroom Projects, i.e, Family & Consumer Science, Industrial Technology	Project Cost	Student pays cost that is beyond the standard project provided by the school.
Advanced math or science classes	Specialized calculators	Some calculators will be available at school. If lost or damaged a replacement fee will be assessed at a rate established by the school. Students are encouraged but not required to purchase such equipment for their personal use.
Copies	Use of school copiers (except for one copy of the student file, which will be provided without charge)	Ten cents (.10) per page for black/white and twenty-five cents (.25) per page for color when charges apply.
School Meals		Breakfast--\$2.45 Lunch--\$3.35 Milk--\$.55 Prices are maximums based on one meal per day, will vary depending on the number of meals or items purchased by the student, and may be adjusted during the year.
Post-secondary education classes	Tuition and fees for college courses taken for credit.	None--Any postsecondary education costs are to be paid directly by students to the college.

End of year lost or damaged books	Damage fee or replacement cost	Fees and fines up to \$25.00 for damaged books. Lost books or ruined books are charged replacement cost, generally at a maximum of \$150.00				
Yearbooks - Optional	School Book	Yearbooks are published and made available for purchase every year. Cost is generally about \$40				
College entrance tests and preparation	Prep programs & tests	Costs of college entrance tests or prep courses, such as ACT preparation tutoring, PSAT test, and ACT test, are optional and to be paid directly to the private companies involved.				
Summer school courses	Classes offered during the summer, or at night, if any	Drivers education class: up to \$350.00				
Locker usage	Use of school padlock	\$5.00 fee if damaged or not returned at the end of the year.				
Extracurricular and other programs	General Description of Fee or Material	\$ Amount of Fee (Anticipated or Maximum) or Specific Material Required				
Athletic Programs						
1. Admission	Spectator fees for admission to events	Admission for school hosted events will generally be \$5.00. Admission will be set by NSAA for District and State events hosted by the school.				
2. Athletic Physicals	NSAA required athletic physicals	Cost varies; payable directly to student's physician or clinic.				
3. Equipment and attire	Students are responsible for required equipment and attire appropriate to the sport or activity which are not provided by the school, and are responsible for any optional clothing, equipment, or other items associated with the sport or activity. Uniform items are checked out to students. If lost or damaged students will be assessed fees in the amount of	Required items include athletic undergarments (supporter, bra, socks and undershirts), practice attire, including shorts, shirts, socks and shoes suitable for the activity, and dress attire suitable for team travel. Optional items for which students are responsible include: personal athletic bags, hair ties, sweat bands, non-required gloves, swim goggles, towels, forearm pads and personal medical devices (braces, orthopedic inserts, etc.). Additional required items for particular sports or activities include: <table border="1" data-bbox="966 1785 1485 1892"> <tr> <td>Basketball</td> <td>No additional</td> </tr> <tr> <td>Football</td> <td>Mouthpiece</td> </tr> </table>	Basketball	No additional	Football	Mouthpiece
Basketball	No additional					
Football	Mouthpiece					

	replacement cost.	Golf	Golf bag & clubs
		Speech	Dress attire; copies of research
		Track	No additional
		Volleyball	Volleyball knee pads
		Wrestling	Wrestling head gear
		Cheerleading and Flag Team Squads	Shoes, approved uniforms (top & skirt; jacket), poms and other accessories
4. Travel meals	Meals	Students are responsible for their own meals while traveling.	
5. Locker use	Padlock for locker	\$5.00 fee if damaged or not returned at the end of the year.	
6. Camps and clinics	Registration and other costs of camps or clinics	Students are responsible for the cost of all clinics, camps and conditioning programs. Any personal items purchased at camps or clinics, such as t-shirts, shall be at the student's expense.	
7. Athletic Clubs	Clubs supporting the athletic program	Currently no dues required. Annual dues not to exceed \$50.00 per club.	

8. Marching Band and Musical Groups	Equipment and attire.	Students will be responsible for the same costs as are set out for the athletic program. Students will be responsible for supplying their own musical instruments and accessories and for their own uniforms.
Music Optional Show Choir	Coordinating group attire	Students will pay for outfits selected by the group. Cost will be based on selection at a maximum of \$150
Clubs/Organizations		
FFA	State & national dues, meals and activities	Annual dues not to exceed \$50.00 per club.
Future Career/Community Leaders (FCCLA)	State & national dues, meals and activities	Annual dues not to exceed \$50.00 per club.
National Honor Society	State & national dues, meals and activities	Currently no dues required. Annual dues not to exceed \$50.00 per club.
Swing Choir	Attire	Students are responsible for purchasing outfits and accessories. Not to exceed \$150.
All Girls Swing Choir	Attire	Students are responsible for purchasing outfits and accessories.
Student Council	State & national dues, meals and activities	Currently no dues required. Annual dues not to exceed \$50.00 per club.
Social & Recognition Activities		
1. School plays, musicals and social activities	Admission to events	Up to \$10.00 per play or activity
2. School dances	Admission to prom, homecoming, etc.	Up to \$10.00 per event

<p>3. Class dues</p>		<p>Currently no dues are assessed. Each of the six secondary classes may assess its members an amount not to exceed \$50.00 annually for rental and decoration of dance facilities, punch and snacks at social activities, memorials and recognition plaques, flowers, and cards, and similar class activities. The payment of such an assessment shall be strictly voluntary, but students who do not pay may be denied admission to extracurricular activities supported by the class dues.</p>
<p>4. Picture Packets</p>	<p>Optional - Pictures are still taken for use in school yearbook.</p>	<p>Students purchase packets as desired and pay directly to photo company.</p>
<p>5. Senior recognition assessment</p>	<p>Optional graduation activities</p>	<p>Participation in class activities attendant to graduation (such as being part of the composite picture, special yearbook pages, etc.) is not required in order for students to receive their high school diploma. Students who choose to participate will be required to pay the cost of the items involved in the graduation ceremony and attendant class activities. These may include the rental of graduation robes, caps, tassels, class flowers, one mother's flower, class gift, yearbook picture page, and class composite picture. A single Senior Class Recognition Assessment, not to exceed \$50, will be assessed to those Seniors who elect to participate in such activities. Expenses for above mentioned items will be paid out of the "Class Activity" account until funds are depleted. After this fund is empty, students will be responsible for all optional graduation activity costs.</p>
<p>6. Trips</p>	<p>Transportation, lodging, meals, admission to events, etc.</p>	<p>For the extracurricular trips, students will be responsible for meals. Students are responsible for costs of school sponsored trips where the trip is an extracurricular activity. The maximum costs of such trips will be \$3,000 per student. If the trip is not school sponsored, the costs of the trip are not subject to this policy and no fee waivers will apply. A trip is not school sponsored if: it is not supervised or administered by the school, attendance on the trip does not count towards graduation</p>

		credit or grade advancement, and participation on the trip is voluntary for students.
--	--	---

Students

School Wellness Policy

An aim of Pender Public Schools (“District”) is to provide curriculum, instruction, and experiences in a health-promoting school environment to instill habits of lifelong learning and health. Therefore, the Board of Education adopts the following School Wellness Policy.

1. District Wellness Committee

Committee Role and Membership

The District will convene a representative District Wellness Committee (“DWC”) or work within an existing school health committee that meets at least annually to establish goals for and oversee school health and safety policies and programs, including development, implementation and periodic review and update of this District wellness policy.

The DWC membership will represent all school levels and include (to the extent possible), but not be limited to: parents and caregivers; students; representatives of the school nutrition program; physical education teachers; health education teachers; school health professionals or staff; mental health and social services staff; school administrators; Board of Education members; and the general public. When possible, membership will also include Supplemental Nutrition Assistance Program Education coordinators. To the extent possible, the DWC will include representatives from each school building and reflect the diversity of the community.

Leadership

The Superintendent or Designee(s) will convene the DWC and facilitate development of and updates to the wellness policy, and will ensure each school’s compliance with the policy.

Each school will designate a school wellness policy coordinator, who will ensure compliance with the policy.

2. Wellness Policy Implementation, Monitoring, Accountability and Community Engagement

Implementation Plan

The District will develop and maintain a plan for implementation to manage and coordinate the execution of this wellness policy. The plan delineates roles, responsibilities, actions and timelines specific to each school; and includes information about who will be responsible to make what change, by how much, where and when; as well as specific goals and objectives for nutrition standards for all foods and beverages available on the school campus, food and beverage marketing, nutrition promotion and

education, physical activity, physical education and other school-based activities that promote student wellness. It is recommended that the school use the Healthy Schools Program online tools to complete a school-level assessment based on the Centers for Disease Control and Prevention's School Health Index, create an action plan that fosters implementation and generate an annual progress report.

This wellness policy and the progress reports can be found at the District's website.

Recordkeeping

The District will retain records to document compliance with the requirements of the wellness policy at the Superintendent's office and/or on the District's computer network. Documentation maintained in this location will include but will not be limited to:

- The written wellness policy;
- Documentation demonstrating that the policy has been made available to the public;
- Documentation of efforts to review and update the Local Schools Wellness Policy; including an indication of who is involved in the update and methods the district uses to make stakeholders aware of their ability to participate on the DWC;
- Documentation to demonstrate compliance with the annual public notification requirements;
- The most recent assessment on the implementation of the local school wellness policy;
- Documentation demonstrating the most recent assessment on the implementation of the Local School Wellness Policy has been made available to the public.

Annual Notification of Policy

The District will actively inform families and the public each year of basic information about this policy, including its content, any updates to the policy and implementation status. The District will make this information available via the District website and/or district-wide communications. The District will provide as much information as possible about the school nutrition environment. This will include a summary of the District's events or activities related to wellness policy implementation. Annually, the District will also publicize the name and contact information of the District officials leading and coordinating the committee, as well as information on how the public can get involved with the school wellness committee.

Triennial Progress Assessments

At least once every three years, the District will evaluate compliance with the wellness policy to assess the implementation of the policy and include:

- The extent to which the District's schools are in compliance with the wellness policy;
- The extent to which the District's wellness policy compares to [a] the Alliance for a Healthier Generation's model wellness policy; and

- A description of the progress made in attaining the goals of the District's wellness policy.

The position/person responsible for managing the triennial assessment and contact information is the Superintendent or Designee.

The DWC, in collaboration with individual schools, will monitor schools' compliance with this wellness policy.

The District will notify households/families of the availability of the triennial progress report.

Revisions and Updating the Policy

The DWC will update or modify the wellness policy based on the results of the annual School Health Index and triennial assessments and/or as District priorities change; community needs change; wellness goals are met; new health science, information, and technology emerges; and new Federal or state guidance or standards are issued. The wellness policy will be assessed and updated as indicated at least every three years, following the triennial assessment.

Community Involvement, Outreach and Communications

The District will communicate ways in which representatives of DWC and others can participate in the development, implementation and periodic review and update of the wellness policy through a variety of means appropriate for that district. The District will also inform parents of the improvements that have been made to school meals and compliance with school meal standards, availability of child nutrition programs and how to apply, and a description of and compliance with Smart Snacks in School nutrition standards. The District will use electronic mechanisms, such as email or displaying notices on the District's website, as well as non-electronic mechanisms, such as newsletters, presentations to parents, or sending information home to parents, to ensure that all families are actively notified of the content of, implementation of, and updates to the wellness policy, as well as how to get involved and support the policy. The District will ensure that communications are culturally and linguistically appropriate to the community, and accomplished through means similar to other ways that the District and individual schools are communicating important school information with parents.

The District will notify the public about the content of or any updates to the wellness policy annually, at a minimum. The District will also use these mechanisms to inform the community about the availability of the annual and triennial reports.

3. Nutrition

School Meals

All schools within the District that participate in USDA child nutrition programs, including the National School Lunch Program (NSLP), the School Breakfast Program (SBP), and any additional Federal child nutrition programs will meet the nutrition requirements of such programs.

Competitive Foods and Beverages

The foods and beverages sold and served outside of the school meal programs (e.g., “competitive” foods and beverages) will meet the USDA Smart Snacks in School nutrition standards, at a minimum.

To support healthy food choices and improve student health and well-being, all foods and beverages outside the reimbursable school meal programs that are sold to students on the school campus during the school day will meet or exceed the USDA Smart Snacks nutrition standards or, if the state policy is stronger, will meet or exceed state nutrition standards. These standards will apply in all locations and through all services where foods and beverages are sold, which may include, but are not limited to, à la carte options in cafeterias, vending machines, school stores and snack or food carts.

Celebrations and Rewards

All foods offered on the school campus will meet or exceed the USDA Smart Snacks in School nutrition standards or, if the state policy is stronger, will meet or exceed state nutrition standards, including through:

1. Celebrations and parties. The District will provide a list of healthy party ideas to parents and teachers, including non-food celebration ideas.
2. Classroom snacks brought by parents. The District will provide or make available to parents a list of foods and beverages that meet Smart Snacks nutrition standards.
3. Rewards and incentives. The District will provide teachers and other relevant school staff a list of alternative ways to reward children or other comparable resources. Foods and beverages will not be used as a reward, or withheld as punishment for any reason, such as for performance or behavior.

Fundraising

Foods and beverages that meet or exceed the USDA Smart Snacks in Schools nutrition standards may be sold through fundraisers on the school campus during the school day

Nutrition Promotion

Nutrition promotion and education positively influence lifelong eating behaviors by using evidence-based techniques and nutrition messages, and by creating food environments that encourage healthy nutrition choices and encourage participation in school meal programs. The District will promote healthy food and beverage choices for all students throughout the school campus, as well as encourage participation in school meal programs.

Nutrition Education

The District will teach, model, encourage and support healthy eating by all students.

Food and Beverage Marketing in Schools

Any foods and beverages marketed or promoted to students on the school campus during the school day will meet or exceed the USDA Smart Snacks in School nutrition standards or, if stronger, state nutrition standards, such that only those foods that comply with or exceed those nutrition standards are permitted to be marketed or promoted to students.

Food and beverage marketing is defined as advertising and other promotions in schools. This term includes, but is not limited to the following:

- Brand names, trademarks, logos or tags, except when placed on a physically present food or beverage product or its container.
- Displays, such as on vending machine exteriors
- Corporate brand, logo, name or trademark on school equipment, such as marquees, message boards, scoreboards or backboards (Note: immediate replacement of these items are not required; however, districts will replace or update scoreboards or other durable equipment when existing contracts are up for renewal or to the extent that it is financially possible over time so that items are in compliance with the marketing policy.)
- Corporate brand, logo, name or trademark on cups used for beverage dispensing, menu boards, coolers, trash cans and other food service equipment; as well as on posters, book covers, pupil assignment books or school supplies displayed, distributed, offered or sold by the District.
- Advertisements in school publications or school mailings.
- Free product samples, taste tests or coupons of a product, or free samples displaying advertising of a product.

As the District/school nutrition services/Athletics Department/PTA/PTO reviews existing contracts and considers new contracts, equipment and product purchasing (and replacement) decisions should reflect the applicable marketing guidelines established by the District wellness policy.

4. Physical Activity

Children and adolescents are encouraged to participate in at least 60 minutes of physical activity every day.

Physical activity during the school day (including but not limited to recess, classroom physical activity breaks or physical education) will not be withheld as punishment. The District will provide teachers and other school staff with a list of ideas or resources for alternative ways to discipline students.

Glossary

School Campus: areas that are owned or leased by the school and used at any time for school-related activities, including on the outside of the school building, school buses or other vehicles used to transport students, athletic fields and stadiums (e.g., on scoreboards, coolers, cups, and water bottles), or parking lots.

School Day: the time between midnight the night before to 30 minutes after the end of the instructional day.

Triennial – recurring every three years.

Legal Reference: Healthy, Hunger-Free Kids Act of 2010, 42 U.S.C. section 1758b; 7 CFR sections 210.11 and 210.30; National School Lunch Program, 42 U.S.C sections 1751-1760, 1770; Regulations and Procedures for Accreditation of Schools, NDE Rule 10

Date of Adoption: August 13, 2007

Date of Amendment: March 13, 2017

Administrative Regulation for School Wellness Policy**Additional Wellness Goals, Nutrition Guidelines and Implementation Plan**

The School Wellness Policy establishes a mission of providing a curriculum, instruction, and experiences in the environment of a health-promoting school community, to instill habits of lifelong learning and health. The School Wellness Policy authorizes the Superintendent to establish such further goals and nutrition guidelines as are determined appropriate to meet the stated mission. This regulation sets forth additional goals and nutrition guidelines as appropriate to meet the District's school wellness mission and implement the School Wellness Policy.

Nutrition Education Activities to Promote Student Wellness

The base goal is to implement a curriculum that meets or exceeds the health and nutrition education objectives established by the Nebraska Department of Education. The administration establishes the following additional goals and actions to achieve such goals:

1. Curriculum: Nutrition education will be integrated into other subjects to complement, but not replace, the health and nutrition education curriculum that is provided in accordance with NDE Rule 10. Educators are to incorporate the promotion of healthy eating nutrition lifestyles in all subject areas as appropriate.
2. Display Nutrition Education Materials: The cafeteria shall display posters or other communications suitable to the ages of students served that promote healthy nutrition choices (e.g., display food pyramid). Educators are encouraged to incorporate such communications in their classrooms as well.
3. Nutrition Health Events: Educators are encouraged to search for and take advantage of events that promote nutrition education. Activities may include:
 - a. health fairs
 - b. traveling health exhibits
 - c. field trips to farm or food production facilities
 - d. school gardens
 - e. health speakers (school assemblies or class speakers on nutrition)
4. Family:
 - a. Parents are to be welcomed to join their children at school lunch as appropriate.
 - b. School communications to parents will include information about healthy nutrition; such as by including information about healthy snacks for children.
5. Staff: Our employees are encouraged to be healthy role models for students. It is important for students to receive consistent messages. Staff is discouraged from eating foods or drinking beverages of minimal nutritional value during the school day in the presence of students.

Physical Activities to Promote Student Wellness

The established goal is to implement a curriculum that meets or exceeds the health and physical education objectives established by the Nebraska Department of Education. The administration establishes the following additional goals and actions to achieve such goals:

1. Curriculum: Health and physical education will be integrated into other subjects to complement, but not replace, the health and physical education curriculum provided in accordance with NDE Rule 10. Educators are to incorporate physical activity promotion and non-sedentary lifestyles in all subject areas as appropriate.
2. Physical Activity During the School Day:
 - a. Recess:
 - i. Elementary students will have the opportunity for daily recess. Weather and other conditions permitting, recess will be outdoors. Students who are idle during recess are to be encouraged by supervising staff to engage in physical activity. Daily minimums are as follows: Pre-school: 30 minutes; Grades K-3: 50 minutes (15 for ½ day Kindergarten); Grades 4-6: 35 minutes. Minimums include lunch recess. Minimums are set for “ordinary” days and are subject to modification in the judgment of the educator when events such as field trips, testing, etc. occur during the day.
 - ii. Middle School and High School students will have the opportunity for physical activity during their lunch period. The gym or outside facilities will be open to use during lunch when possible.
 - b. Class Time: Physical activity within class periods (e.g. stretching breaks when students are at task for more than 50 minutes) will be encouraged.
3. Physical Activity To/From School:
 - a. To encourage biking or walking to school, the administration will work with law enforcement and as appropriate volunteer parent safety monitors to provide safe routes to school. Bike racks will be established commensurate with need.
 - b. In establishing bus pick up/drop off sites, the fact that students will have to walk farther from a particular site will not necessarily be considered as a negative factor.
4. As Punishment: Physical activity will not be used as punishment and will not be withheld as punishment. This guideline shall not apply to extra-curricular activities. Educators may use appropriate professional discretion to make exceptions to this guideline. In no event, however, will physical activity be used as a form of corporal punishment.
5. Display Physical Activity Educational Materials: The cafeteria, gym and health classrooms shall display posters or other communications suitable to the ages of students served that promote physical activity and non-sedentary lifestyles (e.g., display sports posters, walking fitness posters). Educators are encouraged to

incorporate such communications in their classrooms as well.

6. Physical Activity Health Events: Educators are encouraged to search for and take advantage of events that promote physical activity education. Activities may include:
 - a. health fairs
 - b. traveling health exhibits
 - c. field trips to physical activity centers
 - d. physical activity speakers (school assemblies or class speakers representing sports figures, medical people)

7. Family:
 - a. The school's physical activity facilities (playground, gym) will be made available to use by parents with their children outside the normal school day, subject to priority use being for children and subject to other competing uses and safety and risk management considerations.
 - b. School communications to parents will include information that promotes physical activity. Such communications may include information about the benefits of physical activity to children and the distribution of information about youth sports programs.

8. Staff: Our employees are encouraged to be healthy role models for students. It is important for students to receive consistent messages. Staff is encouraged to be seen engaging in non-sedentary lifestyles. For example, staff is encouraged to walk or bike to work; use stairs even if an elevator available; and share as appropriate personal information about physical activities they engage in to remain fit.

Other School Activities to Promote Student Wellness

The established goal is to offer other suitable opportunities to students to engage in health-promoting activities. The administration establishes the following additional goals and actions to achieve such goals:

1. Extracurricular Programs: The District will offer athletic and other activity programs subject to and in compliance with the bylaws of the Nebraska School Activities Association. Secondary school students will be offered the opportunity to participate in intramural sports activities commensurate with their interests and school resources.

2. After-School Facility Uses: The school's physical activity facilities (playground, gym) will be made available to use by students outside the normal school day, subject to other competing uses and safety and risk management considerations.

3. Advertising: The administration will monitor advertising that occurs in the school and endeavor to limit messages that promote foods of minimal nutritional value.

4. Staff Development:
 - a. Professional staff members will be provided with professional development and guidance on appropriate practices and procedures to implement the school wellness goals and recommendations. Professional development activities will include activities each year related to the integration of physical activities and nutrition education into the academic curriculum, use of food as rewards and denial of physical activities as a disciplinary consequence, and other wellness goals and activities.
 - b. The District will provide ongoing training and development for food service staff related to nutrition and wellness goals and activities.

5. Community Resources: The administration will coordinate the school wellness program efforts with those available from medical and other community organizations.

Nutrition Guidelines

The established nutrition guidelines for foods available in each school building during the school day are as follows: (1) school breakfast and lunch programs will be offered which meet or exceed the requirements of federal and state law and regulatory authorities and (2) no foods in competition with the school lunch or breakfast program shall be sold or otherwise made available to students anywhere on school premises during the period of one-half hour prior to the serving period for breakfast and lunch and lasting until one-half hour after the serving of breakfast and lunch.

The administration establishes the following additional nutrition guidelines and actions to meet the guidelines:

1. Conditions for School Meals:
 - a. Scheduling meals. Lunch periods will be scheduled at times when students are in need of nutrition (e.g., in the middle of their school day). Students will be provided adequate time to eat. In general students will, upon arrival in the cafeteria, have at least 10 minutes to eat breakfast and 15 minutes to eat lunch.
 - b. Conditions for meals. Efforts shall be made to establish comfortable and relaxed eating conditions. The factors to promote these conditions will be a clean, orderly environment, pleasant food services staff, adequate seating, enforcement of student conduct rules and adequate supervision.

2. Selection of School Meals:
 - a. School Meals: School meals shall at a minimum meet nutrition requirements established by state and federal law. The school food service staff is to offer meals that are of a nutritional value higher than that required. Emphasize is to be on good menu planning principles that offer healthy food choices including lean meats, a variety of fruits and non-fried vegetables daily, whole grains once each week, and low-fat or nonfat milk daily. Locate these choices where they are readily accessible to students.

Limit portion sizes of desserts and fried foods.

- b. Ala carte selections: Elementary students are to be offered balanced meals. Elementary students are not to be sold individual food or beverage selections except for limited portions of low-fat foods, no-fat milk, fruits, and non-fried vegetables. Middle School and High School students may be sold foods and beverage ala carte provided the ala carte items not include foods of minimal nutritional value and that the offerings include fruits, non-fried vegetables, and healthy beverages (waters and 100% fruit juices).
3. Student's Meals From Home: Students will be discouraged from sharing food and be prohibited from sharing foods brought from home. Parents will be encouraged via health promotional materials to make healthy choices for student lunches.
4. Closed Campus. To encourage students to eat a nutritious lunch, students will not be permitted to leave school during the school day for the purpose of lunch. The administration may grant special exceptions to the closed campus rule as needed (e.g., for students with special dietary needs).
5. Vending machines:
 - a. Vending machines will not be available for student use at any school for the period of ½ hour before and ½ hour after breakfast and lunch periods.
 - b. Elementary school students: Vending machines with foods of minimal nutritional value will not be available to use by elementary school students at any time during the school day.
 - c. Middle school students: Vending machines with foods of minimal nutritional value will not be available to use by middle school students for the period of 1 hour before and 1 hour after breakfast and lunch periods.
 - d. High school students: Vending machines with foods of minimal nutritional value will not be available to use by high school students for the period of 1 hour before and 1 hour after breakfast and lunch periods.
 - e. Promotion of Healthy Choices: At least one vending machine in each school building shall include healthy choices (e.g., water, 100% fruit juices, low-fat/non-fat milk, animal crackers, granola bars, whole-grain fruit bars, pretzels, nuts, plain trail mix).
6. Foods available during the school day:
 - a. Water: Students will be allowed access to water during the school day. Water fountains are available. Educators may in their discretion allow students to bring water bottles to classes. Students will not be permitted to bring soda pop or other drinks or food to class.
 - b. Food rewards. Food will not be used as rewards. No foods are to be provided by the school or school staff during instructional time except: healthy foods, foods provided for instructional purposes (e.g., cultural programs, FCS classes, and foods given in accordance with a special

education student's IEP).

- c. Classroom Celebrations:
 - i. Staff is not to offer students foods of minimal nutritional value for classroom celebrations.
 - ii. Parents are to be encouraged to bring healthy foods for classroom celebrations.
7. Fund-raising:
- a. School clubs are not to sell food for the period of ½ hour before and ½ hour after breakfast and lunch periods.
 - b. Student clubs are encouraged to not sell foods of minimal nutritional value as part of fund-raising efforts.
 - c. Each activity sponsor shall report to the Principal the percentage of total fund-raising receipts from sales of foods of minimal nutritional value as of the end of the each school year.
8. School activities/events:
- a. Athletes: Student athletes serve as role models. Coaches are to encourage healthy eating by student athletes. The coaches' conduct rules may limit consumption of foods of minimal nutritional value by their athletes during their sport season.
 - b. Concessions: Concession stands will include healthy food choices. Efforts will be made to reduce offerings of foods of minimal nutritional value.
9. Definition of Foods of Minimal Nutritional Value: For purposes of this regulation, "foods of minimal nutritional value" has the same meaning as in the federal regulations for the National School Lunch program. Foods of minimal nutritional value are as follows:

Food of minimal nutritional value means: (i) In the case of artificially sweetened foods, a food which provides less than five percent of the Reference Daily Intakes (RDI) for each of eight specified nutrients per serving; and (ii) in the case of all other foods, a food which provides less than five percent of the RDI for each of 8 specified nutrients per 100 calories and less than 5% of the RDI for each of eight specified nutrients per serving. The 8 nutrients to be assessed for this purpose are -- protein, vitamin A, vitamin C, niacin, riboflavin, thiamine, calcium, and iron.

Specific foods of minimal nutritional value are:

- (1) Soda Water.
- (2) Water Ices (except those which contain fruit or fruit juices).
- (3) Chewing Gum.
- (4) Certain Candies -- Processed foods made predominantly from sweeteners or artificial sweeteners with a variety of minor ingredients which characterize the following types:

- (i) Hard Candy -- A product made predominantly from sugar (sucrose) and corn syrup which may be flavored and colored, is characterized by a hard, brittle texture, and includes such items as sour balls, fruit balls, candy sticks, lollipops, starlight mints, after dinner mints, sugar wafers, rock candy, cinnamon candies, breath mints, jaw breakers and cough drops.
 - (ii) Jellies and Gums -- A mixture of carbohydrates which are combined to form a stable gelatinous system of jelly-like character, and are generally flavored and colored, and include gum drops, jelly beans, jellied and fruit-flavored slices.
 - (iii) Marshmallow Candies -- An aerated confection composed as sugar, corn syrup, invert sugar, 20 percent water and gelatin or egg white to which flavors and colors may be added.
 - (iv) Fondant -- A product consisting of microscopic-sized sugar crystals which are separated by thin film of sugar and/or invert sugar in solution such as candy corn, soft mints.
 - (v) Licorice -- A product made predominantly from sugar and corn syrup which is flavored with an extract made from the licorice root.
 - (vi) Spun Candy -- A product that is made from sugar that has been boiled at high temperature and spun at a high speed in a special machine.
 - (vii) Candy Coated Popcorn. -- Popcorn which is coated with a mixture made predominantly from sugar and corn syrup.
10. Definition of Healthy Foods: For purposes of this regulation, “healthy foods” means foods that are not foods of minimal nutritional value, and that are low in fats, sodium and sugars, and high per serving in the nutrients which are needed to meet Reference Daily Intakes.

Date of Amendment: September 9, 2013

InstructionParental/Community Involvement in Schools

Thurston County School District No. 87-0001, Pender Public Schools, after having conducted a public hearing concerning parental involvement and participation,

1. In the event any parent, guardian, or educational decisionmaker of a student has a complaint or objection to textbooks, tests, curriculum materials, activities, digital materials, websites or applications used for learning, training materials for teachers, administrators, or staff, and any other instructional materials, the parent, guardian, or educational decisionmaker may request a personal conference with appropriate school personnel to discuss such concerns. The Superintendent or designee shall prepare a complaint form which may be used by a parent, guardian, or educational decisionmaker to express objections to any such instructional material. Such complaint forms shall seek information including, but not limited to, the specific instructional material complained of, the reason for the complaint, and a proposed resolution of the complaint by the parent, guardian, or educational decisionmaker.
2. Upon reasonable advance request, a parent, guardian, or educational decisionmaker will be permitted to attend and monitor courses, assemblies, counseling sessions, and other instructional activities unless the school determines that such attendance would substantially interfere with a legitimate school interest, which includes the interests of the child, other students, and the educational staff.
3. Parents, guardians, and educational decisionmakers are encouraged to communicate to school staff when the parent, guardian, or educational decisionmaker believes it to be appropriate for their child to be excused from testing, classroom instruction, learning materials, activities, guest speaker events, and other school experiences that the parent, guardian, or educational decisionmaker finds objectionable. The Superintendent or designee shall make a provision on the complaint form hereinabove referenced for receiving information from a parent, guardian, or educational decisionmaker concerning what specific testing, classroom instruction, or other school experience the parent finds objectionable, the basis for the objection, and a proposed solution for dealing with the objection that would be satisfactory to the parent, guardian, or educational decisionmaker and consistent with the mission of the District and legitimate school interests. Parents, guardians, and educational decisionmakers are encouraged to contact the building principal with any questions about any test, curriculum, or surveys.
4. Upon request of a parent, guardian, or educational decisionmaker the District will provide access to the education records of their child consistent with applicable law. Access will be provided during regular business hours of the school.
5. The District will notify parents, guardians, and educational decisionmakers when their

child may be subjected to a standard norm referenced or criterion referenced test or standardized tests. When reasonable to do so or required by law, the parents, guardians, or educational decisionmakers will be notified of where a sample of such test might be observed and the date upon which such test will be administered. As to all testing by the District, experimental evaluation methodologies, experimental testing instruments and any testing instrument which would tend to inquire into the values, beliefs, or privacy rights of any student, or parent, guardian, or educational decisionmaker of such student shall be prohibited unless a parent, guardian, or educational decisionmaker requests in writing that such tests be administered to their child.

6. Parents, guardians, and educational decisionmakers will be notified in advance of any school-sponsored survey administered to students of the District when the survey concerns one or more of the following areas:
 - Political affiliations or beliefs of the student or the student's parent, guardian, or educational decisionmaker;
 - Mental or psychological problems of the student or the student's family;
 - Sex behavior or attitudes;
 - Illegal, anti-social, self-incriminating, or demeaning behavior;
 - Critical appraisals of other individuals with whom respondents have close family relationships;
 - Legally recognized privileged or analogous relationships, such as those of lawyers, physicians, and ministers;
 - Religious practices, affiliations, or beliefs of the student or student's parent, guardian, or educational decisionmaker; or
 - Income (other than that required by law to determine eligibility for participation in a program or for receiving financial assistance under such program).

Any survey administered by the District that asks a student to disclose any of the aforementioned topics, including any non-anonymous survey requesting a student provide information relating to drug, vape, alcohol, or tobacco use, then the District will, at least fifteen days prior to the administration of the survey, notify parents, guardians, and educational decisionmakers that their students will receive the survey. This notice must describe the nature and types of questions included in the survey, the purposes and age-appropriateness of the survey, how information collected by the survey will be used, who will have access to such information, the steps that will be taken to protect student privacy, and whether and how any findings or results of such survey will be disclosed. After receiving such notice, parents, guardians, and educational decisionmakers may request a copy of the survey, review the survey, and/or exempt their student from participating in the survey.

No survey requesting sexual information of a student shall be administered to any student in kindergarten through grade six.

No personally identifiable information of any student survey shall be disclosed unless permitted or required by state and federal law.

7. As a general matter substantive decision-making processes will be left to the judgment of the professional staff, administration and the Board of Education, subject to an effort to receive information from parents, guardians, or educational decisionmakers as to any concerns, objections, or other information such parents, guardians, or educational decisionmakers would wish to provide to the school district concerning a parent's, guardian's, or educational decisionmaker's access, involvement, and participation in activities of the school.

Legal Reference: Neb. Rev. Stat. Sections 79-530 to 79-533
Family Educational Rights and Privacy Act, 20 U.S.C. 1232g
Protection of Pupil Rights Amendment, 20 U.S.C. 1232h

Date of Adoption: July 21, 2008
Date of Amendment: August 11, 2014
Date of Amendment: July 16, 2025

InstructionComputerInternet Safety and Acceptable Use PolicyA. Internet Safety Policy

It is the policy of Pender Public Schools to comply with the Children's Internet Protection Act (CIPA) and Children's Online Privacy Protection Act (COPPA). With respect to the District's computer network, the District shall: (a) prevent user access to, or transmission of, inappropriate material via Internet, electronic mail, or other forms of direct electronic communications; (b) provide for the safety and security of minors when using electronic mail, chat rooms, and other forms of direct electronic communications; (c) prevent unauthorized access, including so-called "hacking," and other unlawful activities online; (d) prevent unauthorized online disclosure, use, or dissemination of personal identification information of minors; (e) obtain verifiable parental consent before allowing third parties to collect personal information online from students; and (f) implement measures designed to restrict minors' access to materials (visual or non-visual) that are harmful to minors.

1. Definitions. Key terms are as defined in CIPA. "Inappropriate material" for purposes of this policy includes material that is obscene, child pornography, or harmful to minors. The term "harmful to minors" means any picture, image, graphic image file, or other visual depiction that: (1) taken as a whole and with respect to minors, appeals to a prurient interest in nudity, sex, or excretion; (2) depicts, describes, or represents, in a patently offensive way with respect to what is suitable for minors, an actual or simulated sexual act or sexual contact, actual or simulated normal or perverted sexual acts, or a lewd exhibition of the genitals; and (3) taken as a whole, lacks serious literary, artistic, political, or scientific value as to minors.
2. Access to Inappropriate Material. To the extent practical, technology protection measures (or "Internet filters") shall be used to block or filter Internet, or other forms of electronic communications, access to inappropriate information. Specifically, as required by the CIPA, blocking shall be applied to visual depictions of material deemed obscene or child pornography, or to any material deemed harmful to minors. Subject to staff supervision, technology protection measures may be disabled or, in the case of minors, minimized only for bona fide research or other lawful purposes.
3. Inappropriate Network Usage. To the extent practical, steps shall be taken to promote the safety and security of users of the District's online computer network when using electronic mail, chat rooms, instant messaging, and other forms of direct electronic communications. Specifically, as required by CIPA, prevention of inappropriate network usage includes: (a) unauthorized access, including so-called 'hacking,' and other unlawful activities; and (b) unauthorized disclosure, use, and dissemination of personal identification information regarding minors.

4. Supervision and Monitoring. It shall be the responsibility of all members of the District staff to supervise and monitor usage of the online computer network and access to the Internet in accordance with this policy and CIPA. Procedures for the disabling or otherwise modifying any technology protection measures shall be the responsibility of the Superintendent and the Superintendent's designees.
5. Social Networking. Students shall be educated about appropriate online behavior, including interacting with others on social networking websites and in chat rooms, and cyberbullying awareness and response. The plan shall be for all students to be provided education on these subjects. The Superintendent or the Superintendent's designee shall be responsible for identifying educational materials, lessons, and/or programs suitable for the age and maturity level of the students and for ensuring the delivery of such materials, lessons, and/or programs to students.
6. Parental Consent. The District shall obtain verifiable parental consent prior to students providing or otherwise disclosing personal information online.
7. Adoption. This Internet Safety Policy was adopted by the Board at a public meeting, following normal public notice.

B. Computer Acceptable Use Policy

This computer acceptable use policy is supplemental to the District's Internet Safety Policy.

1. Technology Subject to this Policy. This Computer Acceptable Use Policy applies to all technology resources of the District or made available by the District. Technology resources include, without limitation, computers and related technology equipment, all forms of e-mail and electronic communications, and the internet.
2. Access and User Agreements. Use of the District technology resources is a privilege and not a right. The Superintendent or designee shall develop appropriate user agreements and shall require that employees, students (and their parents or guardians), and others to sign such user agreements as a condition of access to the technology resources, as the Superintendent determines appropriate. Parents and guardians of students in programs operated by the District shall inform the Superintendent or designee in writing if they do not want their child to have access.

The Superintendent and designees are authorized and directed to establish and implement such other regulations, forms, procedures, guidelines, and standards to implement this Policy.

The technology resources are not a public forum. The District reserves the right to restrict any communications and to remove communications that have been posted.

3. Acceptable Uses. The technology resources are to be used for the limited purpose of advancing the District's mission. The technology resources are to be used, in general, for educational purposes, meaning activities that are integral, immediate, and proximate to the education of students as defined in the E-rate program regulations.
4. Unacceptable Uses.

The following are unacceptable uses of the technology resources:

- a. **Personal Gain:** Technology resources shall not be used, and no person shall authorize its use, for personal financial gain other than in accordance with prescribed constitutional, statutory, and regulatory procedures, other than compensation provided by law.
- b. **Personal Matters:** Technology resources shall not be used, and no person shall authorize its use, for personal matters unless the User has entered into a lease agreement or other similar agreement with the School District that makes such use permissible under law.

Occasional use that the Superintendent or designee determines to ultimately facilitate the mission of the District is not prohibited by this provision. Examples of occasional use that may be determined to ultimately facilitate the mission of the District: sending an e-mail to a minor child or spouse; sending an e-mail related to a community group in which an employee is a member where the membership in the community group facilitates the District's mission.

This occasional use exception does not permit use by employees contrary to the expectations of their position. For example, employees may not play games or surf the net for purposes not directly related to their job during duty time; nor may students do so during instructional time.

The occasional use exception also does not permit use of the technology resources for private business, such as searching for or ordering items on the internet for non-school use; or sending an e-mail related to one's own private consulting business.

- c. **Campaigning:** Technology resources shall not be used, and no person shall authorize its use, for the purpose of campaigning for or against the nomination or election of a candidate or the qualification, passage, or defeat of a ballot question.
- d. **Technology-Related Limitations:** Technology resources shall not be used in any manner which impairs its effective operations or the rights of other technology users. Without limitation,

1. Users shall not use another person's name, log-on, password, or files for any reason, or allow another to use their password (except for authorized staff members).
 2. Users shall not erase, remake, or make unusable another person's computer, information, files, programs or disks.
 3. Users shall not access resources not specifically granted to the user or engage in electronic trespassing.
 4. Users shall not engage in "hacking" to gain unauthorized access to the operating system software or unauthorized access to the system of other users.
 5. Users shall not copy, change, or transfer any software without permission from the network administrators.
 6. Users shall not write, produce, generate, copy, propagate, or attempt to introduce any computer code designed to self-replicate, damage, or otherwise hinder the performance of any computer's memory, file system, or software. Such software is often called a bug, virus, worm, Trojan horse, or similar name.
 7. Users shall not engage in any form of vandalism of the technology resources.
 8. Users shall follow the generally accepted rules of network etiquette. The Superintendent or designees may further define such rules.
- e. Other Policies and Laws: Technology resources shall not be used for any purpose contrary to any District policy, any school rules to which a student user is subject, or any applicable law. Without limitation, this means that technology resources may not be used:
1. to access any material contrary to the Internet Safety Policy; or to create or generate any such material.
 2. to engage in unlawful harassment or discrimination, such as sending e-mails that contain sexual jokes or images.
 3. to engage in violations of employee ethical standards and employee standards of performance, such as sending e-mails that are threatening or offensive or which contain abusive language; use of end messages on e-mails that may imply that the District is supportive of a particular religion or religious belief system, a political candidate or issue, or a controversial issue; or sending e-mails that divulge protected confidential student information to unauthorized persons.
 4. to engage in or promote violations of student conduct rules.
 5. to engage in illegal activity, such as gambling.
 6. in a manner contrary to copyright laws.
 7. in a manner contrary to software licenses.
5. Disclaimer. The technology resources are supplied on an "as is, as available" basis. The District does not imply or expressly warrant that any information

accessed will be valuable or fit for a particular purpose or that the system will operate error free. The District is not responsible for the integrity of information accessed, or software downloaded from the Internet.

6. Filter. A technology protection measure is in place that blocks and/or filters access to prevent access to Internet sites that are not in accordance with policies and regulations. In addition to blocks and/or filters, the District may also use other technology protection measures or procedures as deemed appropriate.

Notwithstanding technology protection measures, some inappropriate material may be accessible by the Internet, including material that is illegal, defamatory, inaccurate, or potentially offensive to some people. Users accept the risk of access to such material and responsibility for promptly exiting any such material.

The technology protection measure that blocks and/or filters Internet access may be disabled only by an authorized staff member for bona fide research or educational purposes: (a) who has successfully completed District training on proper disabling circumstances and procedures, (b) with permission of the immediate supervisor of the staff member requesting said disabling, or (c) with the permission of the Superintendent. An authorized staff member may override the technology protection measure that blocks and/or filters Internet access for a minor to access a site for bona fide research or other lawful purposes provided the minor is monitored directly by an authorized staff member.

7. Monitoring. Use of the technology resources, including but not limited to internet sites visited and e-mail transmitted or received, is subject to monitoring by the administration and network administrators at any time to maintain the system and insure that users are using the system responsibly, without notice to the users. Users have no privacy rights or expectations of privacy with regard to use of the District's computers or Internet system. All technology equipment shall be used under the supervision of the Superintendent and the Superintendent's designees.
8. Sanctions. Violation of the policies and procedures concerning the use of the District technology resources may result in suspension or cancellation of the privilege to use the technology resources and disciplinary action, up to and including expulsion of students and termination of employees. Use that is unethical may be reported to the Commissioner of Education. Use that is unlawful may be reported to the law enforcement authorities. Users shall be responsible for damages caused and injuries sustained by improper or non-permitted use.

Legal Reference: Children's Internet Protection Act, 47 USC § 254
Children's Online Privacy Protection Act, 15 U.S.C. § 6501
FCC Order adopted August 10, 2011
47 USC § 254(h)(1)(b); 47 CFR 54.500(b) and 68 FR 36932 (2003) (E-rate restrictions)
Neb. Rev. Stat. § 49-14,101.01 (Political Accountability and Disclosure Act)

Date of Adoption: July 9, 2012
Date of Amendment: September 9, 2013

Date of Amendment: August 11, 2014
Date of Amendment: August 8, 2016
Date of Amendment: July 10, 2017
Date of Amendment: March 12, 2018

SIGN 1 - OPTION 1

One (1) living donor display.
6mm dibond with digital prints for each panel.
Threaded studs on backside of each panel with paper pattern.
Board and batten boards, use of spacers may be needed.



norfolk • grand island • lincoln
1805 S 13th St
Norfolk, NE 68701
402.371.4674
www.LoveSignCo.com

Designer: Megan Falter
Sales: Tony Maxey
Location: Norfolk, NE
Date: 08/23/2025

PROJECT: 251060_03

Donor Display

CLIENT

Pender Public Schools
609 Whitney Street
Pender, NE 68047

NOTICE

Before approving this artwork please check all names and words for proper spelling, as well as all colors and signage placement if necessary. Questions and or changes need to be addressed before final approval. Once the signage is produced after approval, any and all misspellings or color issues are the responsibility of the client and will be corrected at the expense of the purchaser.

DRAWING APPROVED

CLIENT SIGNATURE

FOR PRESENTATION PURPOSES ONLY.
NOT CONSTRUCTION DOCUMENTS.



© LOVE SIGNS, INC.

ALL RIGHTS RESERVED, NO PART OF THIS DRAWING MAY BE REPRODUCED IN ANY FORM WITHOUT WRITTEN PERMISSION FROM LOVE SIGN CO.

PAGE 1.1



DIBOND PANEL
W/ VINYL PRINT



NOT TO SCALE



norfolk • grand island • lincoln

1805 S 13th St
Norfolk, NE 68701
402.371.4674

www.LoveSignCo.com

Designer: Megan Falter

Sales: Tony Maxey

Location: Norfolk, NE

Date: 08/23/2025

PROJECT: 251060_03

Donor Display

CLIENT

Pender Public Schools
609 Whitney Street
Pender, NE 68047

NOTICE

Before approving this artwork please check all names and words for proper spelling, as well as all colors and signage placement if necessary. Questions and or changes need to be addressed before final approval. Once the signage is produced after approval, any and all misspellings or color issues are the responsibility of the client and will be corrected at the expense of the purchaser.

DRAWING APPROVED

CLIENT SIGNATURE

FOR PRESENTATION PURPOSES ONLY.
NOT CONSTRUCTION DOCUMENTS.



© LOVE SIGNS, INC.

ALL RIGHTS RESERVED, NO PART OF THIS DRAWING
MAY BE REPRODUCED IN ANY FORM WITHOUT
WRITTEN PERMISSION FROM LOVE SIGN CO.

PAGE 1.2

SIGN 1 - OPTION 2

One (1) living donor display.
 6mm dibond with digital prints for each panel.
 Threaded studs on backside of each panel with paper pattern.
 Board and batten boards, use of spacers may be needed.

**SURVEY
 REQUIRED**

LOVE
Signs
 norfolk • grand island • lincoln
 1805 S 13th St
 Norfolk, NE 68701
 402.371.4674
 www.LoveSignCo.com

Designer: Megan Falter
 Sales: Tony Maxey
 Location: Norfolk, NE
 Date: 08/23/2025

PROJECT: 251060_03

Donor Display

CLIENT

Pender Public Schools
 609 Whitney Street
 Pender, NE 68047

NOTICE

Before approving this artwork please check all names and words for proper spelling, as well as all colors and signage placement if necessary. Questions and or changes need to be addressed before final approval. Once the signage is produced after approval, any and all misspellings or color issues are the responsibility of the client and will be corrected at the expense of the purchaser.

DRAWING APPROVED

CLIENT SIGNATURE

FOR PRESENTATION PURPOSES ONLY.
 NOT CONSTRUCTION DOCUMENTS.



© LOVE SIGNS, INC.
 ALL RIGHTS RESERVED, NO PART OF THIS DRAWING MAY BE REPRODUCED IN ANY FORM WITHOUT WRITTEN PERMISSION FROM LOVE SIGN CO.

PAGE 1.3



DIBOND PANEL
 W/ VINYL PRINT



NOT TO SCALE



norfolk • grand island • lincoln

1805 S 13th St
Norfolk, NE 68701
402.371.4674

www.LoveSignCo.com

Designer: Megan Falter

Sales: Tony Maxey

Location: Norfolk, NE

Date: 08/23/2025

PROJECT: 251060_03

Donor Display

CLIENT

Pender Public Schools
609 Whitney Street
Pender, NE 68047

NOTICE

Before approving this artwork please check all names and words for proper spelling, as well as all colors and signage placement if necessary. Questions and or changes need to be addressed before final approval. Once the signage is produced after approval, any and all misspellings or color issues are the responsibility of the client and will be corrected at the expense of the purchaser.

DRAWING APPROVED

CLIENT SIGNATURE

FOR PRESENTATION PURPOSES ONLY.
NOT CONSTRUCTION DOCUMENTS.



© LOVE SIGNS, INC.

ALL RIGHTS RESERVED, NO PART OF THIS DRAWING MAY BE REPRODUCED IN ANY FORM WITHOUT WRITTEN PERMISSION FROM LOVE SIGN CO.

PAGE 1.4

SIGN 1 - OPTION 3

One (1) living donor display.
 6mm dibond dragon logo with print, 1/2" sintra painted red routed letters
 Brushed silver backer panels with donor panels on top. Donor panels to have standoff, silver standoffs for the black donor panels, black standoffs for the other donor panels
 Board and batten boards, use of spacers may be needed.



norfolk • grand island • lincoln
 1805 S 13th St
 Norfolk, NE 68701
 402.371.4674
www.LoveSignCo.com

Designer: Megan Falter
 Sales: Tony Maxey
 Location: Norfolk, NE
 Date: 08/23/2025

PROJECT: 251060_03

Donor Display

CLIENT

Pender Public Schools
 609 Whitney Street
 Pender, NE 68047

NOTICE

Before approving this artwork please check all names and words for proper spelling, as well as all colors and signage placement if necessary. Questions and or changes need to be addressed before final approval. Once the signage is produced after approval, any and all misspellings or color issues are the responsibility of the client and will be corrected at the expense of the purchaser.

DRAWING APPROVED

CLIENT SIGNATURE

FOR PRESENTATION PURPOSES ONLY.
 NOT CONSTRUCTION DOCUMENTS.



© LOVE SIGNS, INC.
 ALL RIGHTS RESERVED, NO PART OF THIS DRAWING MAY BE REPRODUCED IN ANY FORM WITHOUT WRITTEN PERMISSION FROM LOVE SIGN CO.

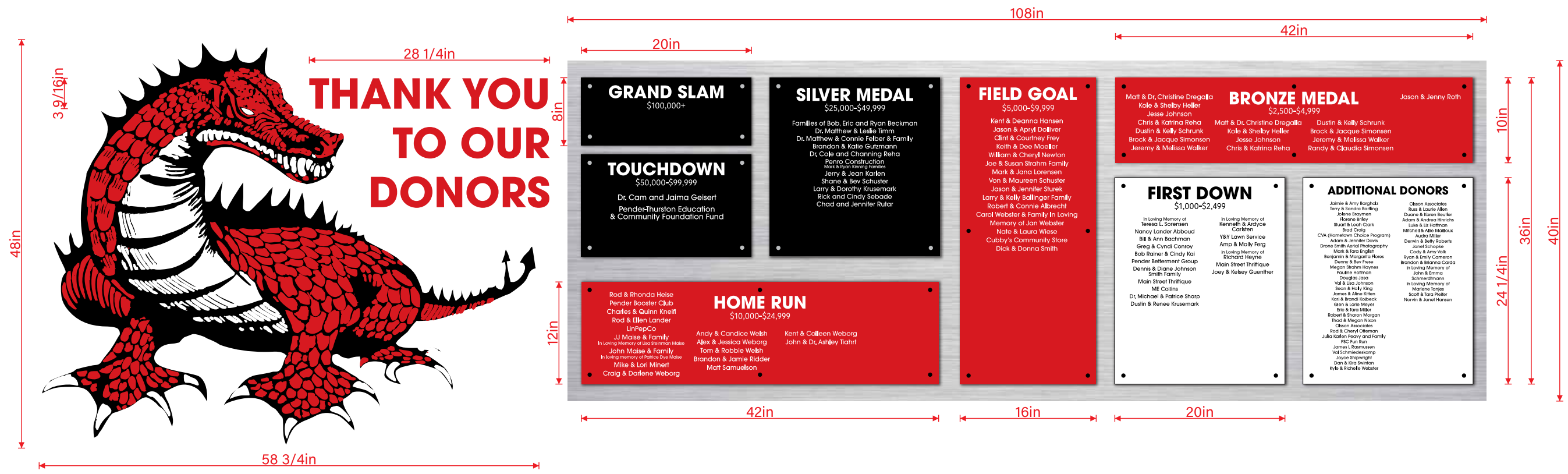

GRAND SLAM
 \$100,000+

TOUCHDOWN
 \$50,000-\$99,999
 Dr. Cam and Jaima Geisert
 Pender-Thurston Education & Community Foundation Fund

SILVER MEDAL
 \$25,000-\$49,999
 Families of Bob, Eric and Ryan Beckman
 Dr. Matthew & Leslie Timm
 Dr. Matthew & Connie Felber & Family
 Brandon & Katie Gutzmann
 Dr. Cole and Channing Reha
 Penro Construction
 Mark & Ryan Kinning Family
 Jerry & Jean Karlen
 Shane & Bev Schuster
 Larry & Dorothy Krusemark
 Rick and Cindy Sebase
 Chad and Jennifer Rutar

FIELD GOAL
 \$5,000-\$9,999
 Kent & Deanna Hansen
 Jason & April Dooliver
 Clint & Courtney Frey
 Keith & Dee Moeller
 William & Cheryl Newton
 Joe & Susan Stamm Family
 Mark & Jana Lorenson
 Von & Maureen Schuster
 Jason & Jennifer Sturek
 Larry & Kelly Ballinger Family
 Robert & Connie Albrecht
 Carol Webster & Family In Loving
 Memory of Jan Webster
 Nate & Laura Wiese
 Cubby's Community Store
 Dick & Donna Smith

BRONZE MEDAL
 \$2,500-\$4,999
 Matt & Dr. Christine Dregalla
 Kate & Shelby Heller
 Jesse Johnson
 Chris & Katrina Reha
 Dustin & Kelly Schruink
 Brock & Jacque Simonsen
 Jeremy & Melissa Walker
 Matt & Dr. Christine Dregalla
 Kate & Shelby Heller
 Jesse Johnson
 Chris & Katrina Reha
 Dustin & Kelly Schruink
 Brock & Jacque Simonsen
 Jeremy & Melissa Walker
 Randy & Claudia Simonsen
 Jason & Jenny Roth

FIRST DOWN
 \$1,000-\$2,499
 In Loving Memory of
 Teresa L. Scorsiani
 Nancy Lander Aboud
 Bill & Ann Bachman
 Greg & Cyndi Conroy
 Bob Rainer & Cindy Kai
 Pender Settlement Group
 Dennis & Diane Johnson
 Smith Family
 Main Street Thriftique
 ME Collins
 Dr. Michael & Patrice Sharp
 Dustin & Renee Krusemark
 In Loving Memory of
 Kenneth & Ardyce
 Carlisle
 Y&Y Lawn Service
 Amp & Molly Ferrg
 In Loving Memory of
 Richard Heynie
 Main Street Thriftique
 Joey & Kelsey Guenther

ADDITIONAL DONORS
 James & Amy Bargatz
 Terry & Sandra Starling
 Johne Strayman
 Renee Briley
 Stuart & Leah Clark
 Brad Crisp
 CVA (Hometown Choice Program)
 Adam & Jennifer Davis
 Drone Smith Aerial Photography
 Mark & Betty English
 Benjamin & Margarita Flores
 Dennis & Bill Heise
 Megan Strahm Haynes
 Pauline Hoffman
 Douglas Josa
 Val & Lisa Johnson
 Sean & Holly King
 James & Aline Kitten
 Karl & Brandi Kibackis
 Glen & Lorie Meyer
 Eric & Tara Miller
 Robert & Sharon Morgan
 Todd & Megan Neam
 Olson Associates
 Rick & Cheryl Ostrom
 Julia Katten Peany and Family
 PSC Fun Run
 James I. Sparsen
 Val Schmiedeknecht
 Joyce Shwright
 Dan & Kira Semken
 Kyle & Rachelle Webster
 Olson Associates
 Russ & Laurie Allen
 Duane & Karen Baulter
 Adam & Andrea Henrichs
 Luke & Liz Hoffman
 Mitchell & Alex McRoux
 Audra Miller
 Dennis & Betty Roberts
 Janet Schoppe
 Cody & Amy Hall
 Ryan & Emily Cameron
 Brandon & Brianna Carida
 In Loving Memory of
 John & Emma
 Schmiedeknecht
 In Loving Memory of
 Madeline Sorger
 Scott & Tara Pfeiler
 Norman & Janet Hansen

HOME RUN
 \$10,000-\$24,999
 Rod & Rhonda Heise
 Pender Booster Club
 Charles & Quinn Kneiff
 Rod & Ellen Lander
 LinPepCo
 JJ Maise & Family
 In Loving Memory of Lisa Beckman Maise
 John Maise & Family
 In Loving Memory of Teresa Dore Maise
 Mike & Lori Minert
 Craig & Darlene Weborg
 Andy & Candice Welsh
 Alex & Jessica Weborg
 Tom & Robbie Welsh
 Brandon & Jamie Ridder
 Matt Samuelson
 Kent & Colleen Weborg
 John & Dr. Ashley Tihart



NOT TO SCALE



norfolk • grand island • lincoln

1805 S 13th St
Norfolk, NE 68701
402.371.4674

www.LoveSignCo.com

Designer: Megan Falter

Sales: Tony Maxey

Location: Norfolk, NE

Date: 08/23/2025

PROJECT: 251060_03

Donor Display

CLIENT

Pender Public Schools
609 Whitney Street
Pender, NE 68047

NOTICE

Before approving this artwork please check all names and words for proper spelling, as well as all colors and signage placement if necessary. Questions and or changes need to be addressed before final approval. Once the signage is produced after approval, any and all misspellings or color issues are the responsibility of the client and will be corrected at the expense of the purchaser.

DRAWING APPROVED

CLIENT SIGNATURE

FOR PRESENTATION PURPOSES ONLY.
NOT CONSTRUCTION DOCUMENTS.



© LOVE SIGNS, INC.

ALL RIGHTS RESERVED, NO PART OF THIS DRAWING
MAY BE REPRODUCED IN ANY FORM WITHOUT
WRITTEN PERMISSION FROM LOVE SIGN CO.

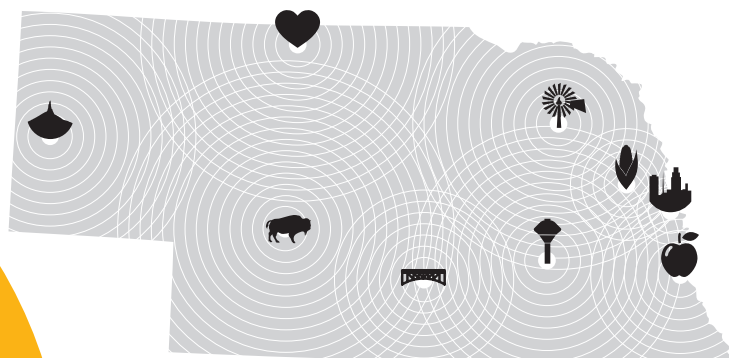

NASB
Nebraska Association of
SCHOOL BOARDS

2025 AREA MEMBERSHIP MEETINGS

Leadership - Training - Recognition - Networking - Vision

Valentine - Gering - Kearney - York - Norfolk - North Platte - Omaha - Nebraska City - Fremont

www.NASBonline.org

2025 REGISTRATION

REGISTER NOW FOR THE MEETING NEAREST YOU

Tuesday, August 19	Valentine	Register by Aug 13
Wednesday, August 20	Gering	Register by Aug 13
Thursday, August 21	Kearney	Register by Aug 13
Tuesday, August 26	York	Register by Aug 21
Wednesday, August 27	Norfolk	Register by Aug 21
Wednesday, September 3	North Platte	Register by Aug 28
Tuesday, September 9	Omaha	Register by Sept 4
Wednesday, September 10	Nebraska City	Register by Sept 4
Wednesday, September 24	Fremont	Register by Sept 18

TO REGISTER

Go to www.NASBonline.org, and log in using your email and password. If you do not have an email and password to log in or have forgotten it, please contact NASB at 402-423-4951 for assistance.

Registration fees for each meeting and dinner are as follows:

NASB Member Registration	\$89
Cancellation Fee	\$25

No refunds after the registration deadlines.

2025 AGENDA

- 4:30 PM - REGISTRATION, NETWORKING & EXHIBITORS
- 5:00 PM - OPENING SESSION
- 5:10 PM - LEGISLATIVE UPDATE
- 5:35 PM - BREAK & EXHIBITORS
- 5:50 PM - TRAINING SESSIONS #1
- 6:30 PM - BREAK & EXHIBITORS
- 6:45 PM - TRAINING SESSIONS #2
- 7:25 PM - NETWORKING DINNER & AWARDS/RECOGNITION

15 AWARDS OF ACHIEVEMENT POINTS WILL BE EARNED FOR ATTENDING



2025 SESSION BREAKDOWN

5:00 PM - WELCOME & OPENING SESSION

JOHN SPATZ, NASB EXECUTIVE DIRECTOR AND MEMBERS OF THE NASB BOARD OF DIRECTORS

5:10 PM - LEGISLATIVE UPDATE

WHAT THEY ATE, WHAT GOT COLD, AND WHAT'S STILL ON THE TABLE

COLBY COASH, NASB ASSOCIATE EXECUTIVE DIRECTOR AND DIRECTOR OF GOVERNMENT RELATIONS

5:50 PM - TRAINING SESSIONS 1

BRAIN SCIENCE – FEAR AND ANXIETY VS EXECUTIVE FUNCTION ... The mental health of students and staff has taken center stage in recent years, especially as social media and other external influences increasingly affect brain development. This session will explore the neuroscience behind fear and anxiety and how they interact with executive function – the brain's ability to manage emotions, focus attention, and make decisions. We will discuss how toxic stress impacts brain development and how we can develop more resilient school districts, school buildings, classrooms, and students. - *John Spatz, Executive Director*

 **WHAT'S NEW WITH SPARQ DATA SOLUTIONS?** ... Learn about our newest product, Sparq Online Publishing. We will walk you through the functionality and how this new application will increase visibility, improve your ability to update your policies quickly and efficiently, and streamline how you receive updates from NASB. Additionally, we will walk through changes and updates to our Sparq Negotiations and Meetings platforms. - *Darion Miller & Nicole Kobus, Sparq Data Solutions*

 **IT'S NOT JUST WHAT YOU DO ... IT'S HOW YOU DO IT: STRATEGIES TO TAKE YOUR GOVERNANCE TEAM TO THE NEXT LEVEL ...** Evaluation of the superintendent and board is the first step toward reciprocal accountability and contributes to a high functioning board-superintendent relationship. Explore board responsibilities, with a focus on cultivating a high-performing leadership team. Whether you are a new board member or an experienced leader, you will gain practical insights and resources to help the board lead with purpose and model accountability through evaluation and self-assessment. - *Marcia Herring, Caden Frank, Stacie Higgins, and Stephanie Summers, NASB Board Leadership*

6:45 PM - TRAINING SESSIONS 2

 **WHAT MAKES POOLING UNIQUE AND BENEFICIAL FOR SCHOOLS?** ... If you're new to your district, new to serving on the school board, or your district is new to ALICAP, this session is perfect for you! We will cover how being a member owner of a pool is exceptional, but also fiscally savvy, for your public school. Public entities are allowed to self-insure, and ALICAP is a prime example of that permission. Come listen to how pooling works best for you and how your school can maximize membership. - *Megan Boldt, Associate Executive Director, Director of ALICAP/Insurance*

CELL PHONES, DRESS CODES, PARENTAL INVOLVEMENT, AND WHAT!? ... The big topics our Legislature dealt with this year, plus the ones they still aren't done with. We haven't seen the last of a few big ideas that were tabled this time around. - *Jim Luebbe, Director of Policy*

FROM VISION TO IMPACT: DRIVING STRATEGIC ALIGNMENT THROUGH COMMUNITY ENGAGEMENT ... Strategic planning is a visionary roadmap sustained through community trust. We will explore how the board leads and supports a process that is inclusive, transparent, and aligned with district priorities. Learn how to engage stakeholders to ensure goals, initiatives, and resources are connected, and get the tools and strategies to help align vision with action to drive lasting impact. - *Marcia Herring, Caden Frank, Stacie Higgins, and Stephanie Summers, NASB Board Leadership*

 Perfect for a newer School Board Member





1311 STOCKWELL STREET
LINCOLN, NE 68502
WWW.NASBONLINE.ORG

RETURN SERVICE REQUESTED

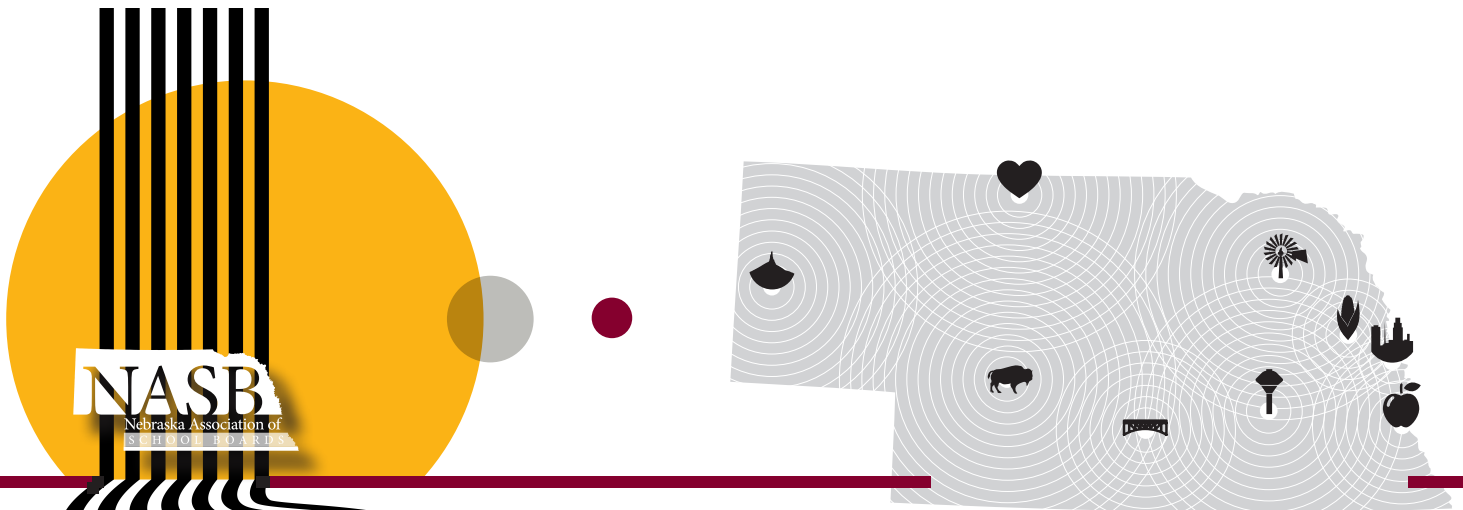

2025 AREA MEMBERSHIP MEETINGS

Leadership - Training - Recognition - Networking - Vision

Valentine - Gering - Kearney - York - Norfolk - North Platte - Omaha - Nebraska City - Fremont