

Board of Education Regular Meeting

Monday, September 18, 2023 8:00 PM

Conference Room #101, 609 Whitney St, Pender, NE 68047-0629

1. **The mission of the Pender Public School District is to provide quality educational opportunities in a safe, positive learning environment that motivates and challenges all students to become productive and responsible citizens.**

2. **Call to Order, Roll Call, Establishment of a Quorum**

3. **Approve Minutes of Previous Meetings**

4. **Financial Report**

5. **Approve Payment of Bills**

6. **2023-2024 Budgets of Expenditure & Levy**

1. 2023-2024 Budgets of Expenditure

2. 2023-2024 System-Wide Tax Request Resolution

7. **Administrative Reports**

8. **Audience with Board**

9. **Vehicle Purchases**

10. **Woodway Curve Trainer**

11. **Personnel**

1. Resignation (Dennis Dolliver)

2. Activities Director

12. **Policy**

13. **ESSER Addition & Classroom Expansion**

14. **Pendragon Sports Complex**

15. **Executive Session**

16. **Reconvene in Open Session**

17. **Upcoming Meetings/Board Opportunities**

1. Labor Relations Conference - October 4-5 - Lincoln

2. Next Regular Meeting - October 16, 2023

3. NASB State Education Conference - November 15-17 - Omaha

18. Adjournment

19. The sequence of agenda topics is subject to change at the discretion of the board. Please arrive at the beginning of the meeting.

PENDER PUBLIC SCHOOL BOARD OF EDUCATION MEETING MINUTES
Pender High School – Room #101
August 21, 2023 – 8:00 p.m.

The Pender Public School Board of Education met in regular session in room 101 on Monday, August 21, 2023. President Matt Peters called the meeting to order at 8:06 p.m. with the following members present: Jason Roth, Jean Karlen, Matt Heineman, Mandy Johnson, and Matt Peters. Also present were Superintendent Jason Dolliver, Secondary Principal Luke Hoffman, Elementary Principal/SPED Director Kelly Ballinger, and Recording Secretary Deanna Hansen.

As required by Nebraska Statute 84-1412(8), President Peters drew the attention of those present to the location of information regarding the Open Meetings Act posted in the meeting room and accessible to all members of the public.

President Peters reviewed the agenda as presented, affirmed that every board member had received notice of the meeting, and confirmed that the time and place of the meeting had been published or posted as required by Board Policy 8342.

A motion to approve the amended minutes of the regular board meeting held on July 17, 2023, was made by Heineman, and seconded by Johnson. President Peters stated the motion and the result of roll call vote being all ayes (4-1-1 Maise absent, Roth abstain); motion carried.

Superintendent Dolliver presented the Financial Reports, reviewing the expenses and revenue for the General, School Nutrition and Activity Funds. He stated the District general fund was in a favorable position, and that a plan was in place to spend down the School Nutrition Fund as required per state guidelines.

The bills were reviewed. Board members asked questions about several invoices.

A motion to approve financial reports and payment of bills as follows: General Fund - \$722,978.07; School Nutrition Fund - \$35,544.47; Activity Fund - \$7,073.48; Employee Benefit Fund - \$3,996.14; Special Building Fund - \$18,547.25; Depreciation Fund - \$127,620.00 and Payroll - \$200,226.06 was made by Roth and seconded by Heineman. President Peters stated the motion and the result of roll call vote being all ayes (5-0, Maise absent); motion carried.

Elementary Principal/SPED Director Kelly Ballinger, Secondary Principal Luke Hoffman and Superintendent Jason Dolliver presented their administrative reports. These reports can be seen in their entirety by logging on to the Pender School website (www.penderschools.org), clicking on the Board of Education tab under the menu button, clicking on the eMeeting button and then clicking on the corresponding meeting and opening the attachment. A printed copy can be obtained at the school. Some of the topics covered in the reports include:

<u>Superintendent</u>	<u>Secondary Principal</u>	<u>Elementary Principal</u>
Professional Goals	Mission Statement	Mission Statement
Conferences, Workshops & Mtgs	23-24 Theme	Professional Goals
Summer Project Update	LB 399	Theme
District Valuation	Workshops, Conf. & Mtgs	Workshops & Meetings
LB 644 Info	Personal Goals	Class Sizes & Splits
2023-24 Budget Plan	7-12 Class Sizes	Fall Benchmarking

Coach/Sponsor Manual
Board Member Recognition
Cattleman's Ball Grant
September Board Meeting

Classroom Breakdown
NCSAS & MAPS Testing
Fall Activity Info/Numbers
7-12 Pendragon PRIDE
National Honor Society
Homecoming 2023

After School Program
Care Closet
Adopt the Breeze
LB399
C5Q Great Reading Race
Pendragon PRIDE
Upcoming Events

Board member Maise arrived at 8:45 pm.

President Peters implemented the Procedures for Public Comment, and no one took advantage of the opportunity to address the board.

Superintendent Dolliver talked with Board members about a property tax request authority increase. He explained the need for the Board to approve a resolution that allows PPS to exceed the newly implemented property tax authority cap by 7%. Prior to LB 243, there was a levy lid and a budget authority lid. LB 243 adds a property tax authority lid. Districts are allowed to grow their property tax by 3% based on LB 243. The bill also allows school districts to exceed that amount by a certain percentage if 70% of Board Members vote to pass a resolution.

He reviewed the resolution with the Board and went on to explain that since Pender has less than 475 students, we can increase our property tax authority by 7%. Schools with larger enrollments can increase their property tax authority by less than 7%. Discussion followed with Board members asking questions and answers being provided. Dr. Dolliver recommended the Board approve the resolution as reviewed.

A motion was made by Roth and seconded by Heineman to approve the resolution to increase the District's overall property tax request authority by an additional seven percent above the base growth percentage, or other maximum amount as permitted by law. President Peters restated the motion and the result of roll call vote being all ayes (6-0); motion carried.

Dr. Dolliver reported to the Board that in early spring we were made aware of a student born after the cutoff date to be enrolled in kindergarten (the cutoff date is July 31, and the student's date of birth is August 3). The family wanted to the student enrolled, so the Board's Early Admittance to Kindergarten Policy (5001) and accompanying Administrative Regulations (5001.1, 5001.2, 5001.3, 5001.4) were utilized. The students met all requirement for early admittance to kindergarten. Superintendent Dolliver recommended the Board approve the early admittance decision.

A motion was made by Karlen and seconded by Roth to approve the early admittance of a student to kindergarten for the 2023-24 school year as reviewed. President Peters restated the motion and the result of roll call vote being all ayes (6-0); motion carried.

Mr. Hoffman reviewed several documents with the Board that outline a School-to-Career Pilot Program. He went on to explain that the idea of this program came our way in somewhat of a haphazard manner but is something that seems to make sense. Dr. Dolliver reported that he and Hoffman met with members of the Committee on American Civics (formerly the Curriculum Committee) earlier in the day to discuss the program and members of the committee were in favor in moving forward with the program on a pilot basis. The discussion was good; Board members asked questions and answers were provided. If the pilot program is approved Policies and AR's will be drafted to meet the needs of the program. At this time, the attached documents that were reviewed will be used. Superintendent Dolliver recommended approving the School-to-Career program on a pilot basis.

A motion was made by Karlen and seconded by Johnson to approve the pilot of the School-to-Career Program as reviewed. President Peters restated the motion and the result of roll call vote being all ayes (6-0); motion carried.

Dr. Dolliver reported to the Board that earlier in the day he had a meeting with members of the Administrative Assistance Committee. One item that was discussed was adding a person to the kitchen staff. After the committee meeting it was decided to move forward with finding someone to work in the kitchen on a part-time basis. This was not deemed to be an item that needed Board action; this was an information item only for communication and transparency purposes only. No action was taken.

Superintendent Dolliver reported Dawn Brauer submitted a letter of resignation. Dr. Dolliver recommended accepting her resignation and thanking her for her service.

A motion was made by Johnson and seconded by Maise to accept the resignation of Dawn Brauer and thank her for her years of service to Pender Public Schools. President Peters restated the motion and the result of roll call vote being all ayes (6-0); motion carried.

Superintendent Dolliver reported that the need to hire 2 paraprofessionals arose in the week before school started. Two qualified people were interviewed for the para positions. Cortnie Walker and Kyla Taylor both accepted work agreements. Robbie Welsh, who served the district as a long-term sub during the 2022-23 school year and is needed again in 23-24 was also offered and accepted a work agreement. Dr. Dolliver recommended approving all three work agreements as reviewed.

A motion was made by Johnson and seconded by Maise to approve the work agreements with Cortnie Walker, Kyla Taylor, and Robbie Welsh as reviewed. President Peters restated the motion and the result of roll call vote being all ayes (6-0); motion carried.

Requests were received from Derick Buck, Ted Stubbs, Jadin Ostrand and Amy Ostrand to be placed on our substitute teacher list for the coming school year. All individuals have met the requirements to be a substitute teacher in Nebraska. Dr. Dolliver recommended approving these requests.

A motion was made by Roth and seconded by Heineman to approve the addition of Derick Buck, Ted Stubbs, Jadin Ostrand and Amy Ostrand to the substitute teacher list. President Peters stated the motion and the result of roll call vote being all ayes (6-0); motion carried.

Superintendent Dolliver reviewed a list of items and asked that they be declared surplus, and disposition be authorized. Board Policy 3090 provides guidelines for declaring items as surplus and disposing of them. Dr. Dolliver recommended approval of the list as presented.

A motion was made by Johnson and seconded by Heineman to declare the list of items as surplus and to authorize the Superintendent to dispose of the items as allowed in Board Policy 3090. President Peters stated the motion and the result of roll call vote being all ayes (6-0); motion carried.

Board Policy 5008 was reviewed a second time. Dr. Dolliver recommended approving the Policy as amended.

A motion was made by Johnson and seconded by Maise to approve the second and final reading of Board Policy 5008. President Peters stated the motion and the result of roll call vote being all ayes (6-0); motion carried.

The annual review of Board Policy 5006 – Option Enrollment and supporting Administrative Regulation 5006.1 – Enrollment Option resulted in a recommendation to accept the enrollment option resolution provided in AR 5006.1 as presented for the 2023-2024 school year.

A motion was made by Johnson and seconded by Karlen to approve Board Policy 5006 – Option Enrollment and Administrative Regulation 5006.1 – Enrollment Option as reviewed and discussed for the 2023-2024 school year. President Peters stated the motion and the result of roll call vote being all ayes (6-0); motion carried.

While a public hearing is not required, Policy 5415 – Anti-Bullying requires an annual review. Board members reviewed Policy 5415 – Anti-Bullying Policy and did not recommend any changes for the 2023-2024 school year.

A motion to adopt Policy 5415 - Anti-Bullying Policy as reviewed was made by Johnson and seconded by Heineman. President Peters stated the motion and the result of roll call vote being all ayes (6-0); motion carried.

President Peters opened the public hearing to hear support, opposition or criticism on the current Student Fee Policy 5416 and AR 5416.1 at 11:11 p.m. President Peters closed the public hearing at 11:12 p.m.

A motion was made by Johnson and seconded by Maise to adopt BOE Policy 5416 and AR 5416.1 as reviewed. President Peters stated the motion and the result of roll call vote being all ayes (6-0); motion carried.

While a public hearing is not required, Policy 5417 – Wellness requires an annual review. Board members reviewed Policy 5417 – Wellness and did not recommend any changes for the 2023-2024 school year.

A motion to adopt Policy 5417 – Wellness as reviewed was made by Johnson and seconded by Roth. President Peters stated the motion and the result of roll call vote being all ayes (6-0); motion carried.

President Peters opened the public hearing to hear support, opposition, or criticism on the current Parental Involvement Policy 6400 at 11:14 p.m. Board members discussed the policy and asked questions. No changes were recommended to these policies designed to provide a format for encouraging parental involvement. President Peters closed the public hearing at 11:17 p.m. No changes were made to Parental Involvement Policy 6400 for the 2023-2024 school year.

A motion was made by Johnson and seconded by Maise to adopt BOE Policy 6400 as reviewed and discussed. President Peters stated the motion and the result of roll call vote being all ayes (6-0); motion carried.

While a public hearing is not required, Policy 6800 – Internet Safety requires an annual review. Board members reviewed Policy 6800 – Internet Safety and did not recommend any changes for the 2023-2024 school year.

A motion was made by Johnson and seconded by Maise to adopt BOE Policy 6800 – Internet Safety as reviewed and discussed. President Peters stated the motion and the result of roll call vote being all ayes (6-0); motion carried.

Superintendent Dolliver provided the Board an update on the ESSER Addition and Classroom Expansion project. Work continues on the HVAC system; the punch list is nearly complete, and a second walk-through will be scheduled soon. No action was needed.

Dr. Dolliver reported that he is still waiting on the final plans for the Timberlyne Building, and that he had updated estimates from Olsson for items that were not included in Option A of the Pendragon Sports Complex. No action was needed.

Board consensus was to hold a final meeting for fiscal year 2022-2023 on Tuesday, August 29, beginning at 7:15 a.m. The primary purpose of the meeting is to approve any final expenditures and to discuss the budget for the 2023-2024 school year.

President Peters reminded Board members the next regular meeting will be held on Monday, September 18, 2023, at 8:00 pm and the NASB Area Membership Meeting is scheduled to occur on September 6 in Norfolk. There is also a P2T Board Meeting on September 18 in West Point.

A motion to adjourn was made by Johnson and seconded by Heineman. President Peters stated the motion and the result of roll call vote being all ayes (6-0); motion carried. The meeting was adjourned at 11:43 p.m.

Jason Roth, Secretary

Deanna Hansen, Recording Secretary

Pender Public Schools

August 2023 General Fund Payables

Check Number	Payee	Type	Amount
40357	AFLAC-12	August Payroll Liability	\$911.51
40358	Blue Cross Blue Shield of NE	August Payroll Liability	\$72,640.33
40359	Credit Management Services	August Payroll Liability	\$53.95
40360	Department of Revenue	August Payroll Liability	\$9,818.22
EFT	Employee Benefit Fund	August Payroll Liability	\$3,708.36
40361	Frontier Bank	August Payroll Liability	\$61,974.66
40362	Madison National Life Ins Co, Inc	August Payroll Liability	\$1,474.87
40363	Nebraska School Retirement	August Payroll Liability	\$49,016.05
40364	Pender General Fund	August Payroll Liability	\$999.17
40365	Special Building Fund	August Payroll Liability	\$231.67
40366	Vision Service Plan	August Payroll Liability	\$638.79
EFT	HSA Account Contributions	August Payroll Liability	\$5,182.59
40427	ABC Mobile Storage Inv	Storage Unit Rent	\$175.00
40428	Amazon Capital Services	Accounts Payable	\$5,243.79
40369	Apptegy	Website Annual Renewal	\$3,700.00
40370	Canon Financial Services	Copier Lease, Overages & Property Tax	\$3,561.36
40371	Carpenter Paper Company	Custodial Supplies	\$547.94
40372	Carrier Container Company	Rolloff Container	\$1,050.00
40373	CDW*G	Accounts Payable	\$2,835.36
40432	Cubbys	Fuel	\$663.13
40375	Dunn's Plumbing and Heating	Repairs	\$215.00
40376	Educational Service Unit #1	4th Quarter SPED	\$90,811.97
40429	Educational Service Unit #8	APEX (Distance Learning)	\$6,275.00
40377	Essential Screens	Background Checks	\$77.50
40378	Fastwyre Broadband	Telephone	\$312.56
40379	First National Bank	Accounts Payable	\$1,805.24
40380	Flooring Solutions	Carpet	\$2,782.33
40381	Frazeys	Accounts Payable	\$87.31
40382	Grainger	Maintenance & Building Supplies	\$739.14
40383	hand2mind, Inc.	Classroom Supplies	\$509.96
40430	Hudl	Annual Renewal	\$6,000.00
40384	Innovative Office Solutions, LLC	Classroom Supplies	\$29.95
40385	IXL Learning	Annual Renewal	\$4,663.00
40386	J.F. Ahern Co.	Fire System Repairs	\$6,997.00
40387	Janke Auto Co.	Van & Bus Inspections/Maintenance	\$545.35
40388	Jason Sears Flooring	Remove & Replace Tile New Gym Restrooms	\$20,393.50
40389	Jerico Construction LLC	Concrete	\$70,560.00
40390	JourneyEd, Inc.	Adobe Renewal	\$500.00
40391	Kings Disposal Co	Trash Removal Service through 8-31-2024	\$8,200.00
40392	L. Jake Jacobsen	Professional Fee	\$1,247.59
40393	Lamp Auto Parts	Mower Switch	\$92.67
40395	Lorensen Lumber & Grain	Maintenance Supplies	\$216.83
40396	Maise Electrical & Mechanical	Remodel New Gym Restrooms	\$27,103.28
40397	Matheson Tri-Gas, Inc.	Welding Gas and Bottle Rent	\$287.92
40398	NASB ALICAP	2023-24 Insurance Premium	\$98,529.00
40399	National Art & School Supplies	Classroom Supplies	\$736.27
40400	NE Council of School Admin	Professional Dues & Registration Fees	\$1,059.00
40401	Nebraska Safety Center	Driver Training	\$620.00
40402	Newton Diesel	Bus Repair	\$617.37
40403	Orkin Pest Control	Exterminator for 23-24	\$2,496.00
40404	Pender Ace Hardware	Maintenance & Custodial Supplies	\$631.37
40405	Pender Activity Fund	Reimbursement	\$11,683.98

40406	Pender Body & Glass	Van Repair	\$47.50
40407	Pender Community Hospital	DOT Physicals	\$525.00
40431	Pender Depreciation Fund	Budgeted Transfer	\$85,000.00
40408	Pender Grain Inc	Weed Spray	\$105.00
40409	Pender Municipal Utilities	July Usage	\$15,496.15
40410	Pender School Nutrition Fund	Reimbursement	\$239.34
40411	Pender-Thurston Chamber	Chamber Bucks	\$600.00
40412	Petty Cash Fund	Reimbursement	\$1,992.53
40413	Quill Corporation	Office Supplies	\$131.88
40414	Rasmussen Mechanical Services	AC Repair	\$17,160.00
40415	Rays Midbell	Instrument Repairs	\$185.30
40416	Ricks Computers, Inc.	MacBook Repair	\$90.00
40418	Schmader Landfill, LLC	Garbage Disposal	\$30.00
40419	Schoolmate	Classroom Supplies	\$528.00
40420	Studies Weekly	Social Studies Curriculum (Grades K-1, 6 yrs)	\$5,302.61
40421	Sturek Media, Inc.	Printing	\$518.88
40422	Subway #39822-0	New Teacher Orientation & Board Meeting	\$102.67
40423	Travis Williams	Repairs	\$1,000.00
40424	Verizon Wireless	Cell Phone Booster & Wi-Fi	\$290.17
40425	Vivacity Tech PBC	Chromebook Sleeves	\$278.20
40426	Zaner-Bloser Handwriting	Handwriting Curriculum	\$2,102.00
		General Fund Total	\$722,978.07
		August Payroll Total	\$200,226.06
		School Nutrition Fund Total	\$35,544.47
		Employee Benefit Fund Total	\$3,996.14
		Depreciation Fund Total	\$127,620.00
		Special Building Fund Total	\$18,547.25
		Activity Fund Total	\$7,073.48
		Petty Cash Fund	\$1,992.53

PENDER PUBLIC SCHOOL BOARD OF EDUCATION MEETING MINUTES
Pender Public School – Room 101
August 30, 2023 – 7:15 a.m.

The Pender Public School Board of Education met in special session in room 101 at Pender Public Schools on Wednesday, August 30, 2023. President Peters called the meeting to order at 7:17 a.m. with the following members present: Jason Roth, Matt Peters, J.J. Maise, Mandy Johnson, and Matt Heineman. Also present were Superintendent Jason Dolliver, Secondary Principal Luke Hoffman, Elementary Principal and SPED Director Kelly Ballinger and Recording Secretary Deanna Hansen.

As required by Nebraska Statute 84-1412(8), President Peters drew the attention of those present to the location of information regarding the Open Meetings Act posted in the meeting room and accessible to all members of the public.

A motion was made by Heineman and seconded by Johnson to excuse Board member Karlen. President Peters stated the motion and the result of roll call vote being all ayes (5-0, Karlen absent); motion carried.

President Peters reviewed the agenda as presented, affirmed that all board members had received notice of the meeting and that the time and place of the special meeting had been published.

Superintendent Dolliver reviewed the final expenditures for the 2022-23 fiscal year with Board members, presented final account balances and reviewed the 2022-23 FY Budget Report. Dr. Dolliver recommended approving the payments as presented.

A motion to approve payment of bills as follows: General Fund - \$10,660.00; Employee Benefit Fund - \$339.00 and Special Building Fund - \$6,950.00 was made by Heineman and seconded by Roth. President Peters stated the motion and the result of roll call vote being all ayes (5-0); motion carried.

Final valuation numbers were received on August 20th and a tentative budget for all funds for the 2023-2024 fiscal year was developed. Dr. Dolliver shared details of the proposed budgets and resulting tax levies for all funds. Board members asked questions and provided feedback. Three options were reviewed; the budgets that seemed the most favorable to Board members resulted in a tax request that would require District participation in the joint public hearing required by LB 644. Dr. Dolliver will provide the information needed to County Officials and inform Board members when the Joint Public Hearing is scheduled. Formal approval of the 2023-2024 budget will be considered during the regular Board meeting on September 18, 2023.

President Peters opened the public hearing at 8:05 a.m. for purposes of hearing support, opposition, criticism, suggestions, or observations of taxpayers relating to the proposed amendment of the 2022-2023 Activity Fund Budget of Expenditure.

Superintendent Dolliver reviewed the published notice of amendment for the Activities Fund Budget. The proposed amendment increased the budget of expenditures from \$353,500.00 to \$394,500.00. Dr. Dolliver reviewed revenue and expenditures for the 2022-23 year, highlighting areas that saw significant increase in expenditures. Board members asked questions and answers were provided. No public support, opposition, criticism, suggestions, or observations by taxpayers were presented regarding the proposed amendment of the Activities Fund budget of expenditure.

President Peters closed the public hearing at 8:18 a.m.

A motion was made by Maise and seconded by Johnson to approve the amended 2022/23 Activities Fund budget as reviewed. President Peters stated the motion and the result of roll call vote being all ayes (5-0), motion carried.

President Peters reminded Board members that the NASB Area Membership Meeting is September 6 in Norfolk, a P2T Board Meeting is scheduled for September 18 in West Point at 7:00 pm, and the next regular meeting will be held on Monday, September 18, 2023, at 8:00 p.m.

Motion was made by Roth and seconded by Heineman to adjourn the special meeting. President Peters stated the motion and the result of roll call vote being all ayes (5-0); the meeting was adjourned at 8:22 a.m.

Jason Roth, Secretary

Deanna Hansen, Recording Secretary

General Fund Check Report

Ck #40433	ReTURF Solutions LLC	playground	\$10,660.00
-----------	----------------------	------------	-------------

Special Building Fund Check Report

Ck #1045	CQ Foundation Repair	repairs at Heyne field	\$6,950.00
----------	----------------------	------------------------	------------

Employee Benefit Fund Check Report

Ck #1251	Pender General Fund	summer premium	\$339.00
----------	---------------------	----------------	----------



Pender Public Schools

Financial Report
September 18, 2023

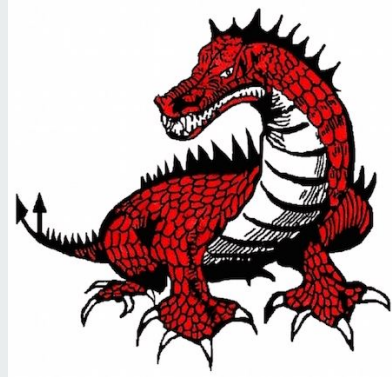



Purpose

- Draw attention to district finance in a way that is more engaging for Board members and anyone who happens to be in attendance
- Infuse more discussion about district finance into monthly Board meeting
 - Designed to be something in addition to the questions and comments made when the checks are approved
- Create a historical catalog, which will be helpful in many ways

FINANCIAL REPORT FOR AUGUST 2023
SCHOOL NUTRITION FUND #346217

Balance - July 31, 2023 **130,965.05**

Student Breakfast/Lunch	21,550.00
Adult Breakfast/Lunch	1,106.00
Federal Reimbursement	29,754.93
State Breakfast/Lunch Reimbursement	
Special Milk Program Receipts	4,333.00
Other Receipts	1,303.23
Interest	90.41

TOTAL REVENUE **58,137.57**

Accounts Payable	22,632.72
Payroll	8,878.68
Payroll Liabilities	<u>12,911.75</u>

TOTAL EXPENDITURES **44,423.15**

Reconciled Balance - August 31, 2023 **\$ 144,679.47**

<i>Reconciled Balance - August 31, 2022</i>	<i>\$ 168,420.51</i>
<i>Reconciled Balance - August 31, 2021</i>	<i>\$ 136,811.18</i>
<i>Reconciled Balance - August 31, 2020</i>	<i>\$ 66,598.97</i>
<i>Reconciled Balance - August 31, 2019</i>	<i>\$ 40,936.35</i>
<i>Reconciled Balance - August 31, 2018</i>	<i>\$ 43,938.21</i>
<i>Reconciled Balance - August 31, 2017</i>	<i>\$ 36,650.97</i>
<i>Reconciled Balance - August 31, 2016</i>	<i>\$ 47,013.57</i>

FINANCIAL REPORT FOR AUGUST 2023
ACTIVITY FUND #346195

Checking Account Balance - July 31, 2023		65,565.33
Certificates of Deposit Balance - July 31, 2023		78,644.80
		<hr/> 144,210.13
Activity Revenue	33,276.88	
Interest Earned	<u>45.77</u>	
TOTAL REVENUE		33,322.65
Activity Expenses	<u>20,859.66</u>	
TOTAL EXPENDITURES		20,859.66
Checking Account Balance - August 31, 2023		78,028.32
Certificates of Deposit Balance - August 31, 2023		78,644.80
		<hr/> 156,673.12
Reconciled Bank Balance - August 31, 2023		\$ 156,465.46
<i>Reconciled Balance - August 31, 2022</i>		<i>\$ 144,067.00</i>
<i>Reconciled Balance - August 31, 2021</i>		<i>\$ 135,676.16</i>
<i>Reconciled Balance - August 31, 2020</i>		<i>\$ 146,770.85</i>
<i>Reconciled Balance - August 31, 2019</i>		<i>\$ 128,802.10</i>
<i>Reconciled Balance - August 31, 2018</i>		<i>\$ 103,074.23</i>
<i>Reconciled Balance - August 31, 2017</i>		<i>\$ 114,339.18</i>
<i>Reconciled Balance - August 31, 2016</i>		<i>\$ 125,876.46</i>
<i>Reconciled Balance - August 31, 2015</i>		<i>\$ 131,078.71</i>

**FINANCIAL REPORT FOR AUGUST 2023
GENERAL FUND #41-200-7**

Balance - July 31, 2023 **2,471,259.83**

Taxes Levied (County Proceeds)	90,117.60	
ESU #2 Reimbursement (Orton Gillingham & Closeup)		
ESU #1 Reimbursement (Perkins)		
NECC Dual Credit Course Reimbursement		
Nebraska Cattleman's Ball Grant proceeds	10,500.00	
2-23-24 Technology Fees collected	5,915.00	
Other Local Receipts	3,841.33	
Interest Earned	4,845.38	
TOTAL REVENUE		115,219.31

Accounts Payable	527,337.90	
Payroll	191,347.38	
Payroll Liabilities	206,650.17	
TOTAL EXPENDITURES		925,335.45

Checking & Super Sweep
Reconciled Balance - August 31, 2023 **\$ 1,661,143.69**

<i>Reconciled Balance - August 31, 2022</i>		<i>\$ 1,733,785.15</i>
<i>Reconciled Balance - August 31, 2021</i>		<i>\$ 1,337,571.40</i>
<i>Reconciled Balance - August 31, 2020</i>		<i>\$ 825,214.70</i>
<i>Reconciled Balance - August 31, 2019</i>		<i>\$ 551,962.60</i>
<i>Reconciled Balance - August 31, 2018</i>		<i>\$ 822,092.93</i>
<i>Reconciled Balance - August 31, 2017</i>		<i>\$ 777,671.78</i>
<i>Reconciled Balance - August 31, 2016</i>		<i>\$ 779,915.81</i>
<i>Reconciled Balance - August 31, 2015</i>		<i>\$ 881,989.24</i>

Current Cash Balance

Sorted by Site ID, Group ID, Activity ID.
From 08/01/2023 to 08/31/2023.

Site ID Group ID	Site Name Group Name	Activity ID	Activity Name	Beginning Cash	Receipts	Disbursements	Adjustments	Cash Balance
PPS	Pender Public Schools							
A	ATHLETICS							
110	BOYS BASKETBALL			2,839.93	0.00	500.00	0.00	2,339.93
115	BOYS GOLF			-6,169.33	2,164.40	0.00	0.00	-4,004.93
120	FOOTBALL			-39,519.53	2,304.00	4,843.30	0.00	-42,058.83
125	GIRLS BASKETBALL			2,050.07	350.10	500.00	0.00	1,900.17
130	GIRLS GOLF			-3,424.04	0.00	0.00	0.00	-3,424.04
135	HS TRACK			-7,073.64	0.00	88.31	0.00	-7,161.95
140	JH BASKETBALL			-15,106.66	0.00	0.00	0.00	-15,106.66
145	JH FOOTBALL			-7,228.93	0.00	0.00	0.00	-7,228.93
150	JH TRACK			-1,749.84	0.00	0.00	0.00	-1,749.84
155	JH VOLLEYBALL			-547.79	0.00	0.00	0.00	-547.79
160	JH WRESTLING			1,728.09	0.00	0.00	0.00	1,728.09
165	VOLLEYBALL			1,700.32	1,190.00	1,486.07	0.00	1,404.25
170	HS WRESTLING			-4,349.81	0.00	0.00	0.00	-4,349.81
175	WEIGHT LIFTING			-7,726.98	0.00	0.00	0.00	-7,726.98
177	Bowling			-1,481.00	0.00	0.00	0.00	-1,481.00
182	BASEBALL			-11,078.54	0.00	40.04	0.00	-11,118.58
185	CROSS COUNTRY			-4,890.01	0.00	956.04	0.00	-5,846.05
195	EQUIPMENT			31,990.04	0.00	0.00	0.00	31,990.04
197	ADVANCE TICKET SALES			41,110.00	5,062.00	0.00	0.00	46,172.00
950	Girls Golf Coop			2,771.11	0.00	400.00	0.00	2,371.11
A Totals:				-26,156.54	11,070.50	8,813.76	0.00	-23,899.80
B	CLASSES							
265	CLASS OF 2021			4,029.50	0.00	0.00	0.00	4,029.50
270	CLASS OF 2022			37.55	0.00	0.00	0.00	37.55
275	CLASS OF 2023			-215.62	0.00	0.00	0.00	-215.62
280	CLASS OF 2024			2,061.40	0.00	0.00	0.00	2,061.40
294	Class of 2025			2,824.05	0.00	552.34	0.00	2,271.71
295	Class of 2017			0.00	0.00	0.00	0.00	0.00
296	Class of 2018			-532.78	0.00	0.00	0.00	-532.78
297	Class of 2019			-433.99	0.00	0.00	0.00	-433.99
298	Class of 2020			838.53	0.00	0.00	0.00	838.53
B Totals:				8,608.64	0.00	552.34	0.00	8,056.30

Current Cash Balance

Sorted by Site ID, Group ID, Activity ID.
From 08/01/2023 to 08/31/2023.

Site ID Group ID	Site Name Group Name	Activity ID	Activity Name	Beginning Cash	Receipts	Disbursements	Adjustments	Cash Balance
C ACADEMIC CLUBS								
315			INSTRUMENTAL	-2,473.95	1,000.00	42.08	0.00	-1,516.03
317			Jazz Band	-2,308.62	0.00	0.00	0.00	-2,308.62
320			One-Act	1,251.73	0.00	0.00	0.00	1,251.73
321			Speech	-5,871.84	100.00	0.00	0.00	-5,771.84
322			QUIZ BOWL	1,127.36	0.00	0.00	0.00	1,127.36
335			NATIONAL HONOR SOCIETY	3,261.89	0.00	125.00	0.00	3,136.89
345			STUDENT COUNCIL	4,271.72	1,200.00	0.00	0.00	5,471.72
350			VOCAL MUSIC	-9,271.55	0.00	0.00	0.00	-9,271.55
360			BOOK FAIR PROCEEDS	-43.58	0.00	0.00	0.00	-43.58
365			CLOSE-UP	6,853.87	830.40	0.00	0.00	7,684.27
370			MUSICAL	6,613.56	0.00	0.00	0.00	6,613.56
375			YEARBOOK	26,747.09	976.50	0.00	0.00	27,723.59
C Totals:				30,157.68	4,106.90	167.08	0.00	34,097.50
E MISCELLANEOUS								
410			STRIV	-1,056.02	0.00	0.00	0.00	-1,056.02
420			Elementary Box Top Money	1,475.01	0.00	0.00	0.00	1,475.01
430			Heese Event Center Contributions	477.00	0.00	0.00	0.00	477.00
435			SPED Fundraising	5,018.66	0.00	0.00	0.00	5,018.66
440			CHEERLEADING	-372.81	0.00	0.00	0.00	-372.81
445			MISCELLANEOUS	112.80	2,266.00	4,462.00	-255.52	-2,338.72
450			F&R Sponsor Pd by District	-11,541.88	11,683.98	25.56	0.00	116.54
455			Care Closet	0.00	1,500.00	0.00	0.00	1,500.00
500			DONATION	25,153.30	0.00	0.00	0.00	25,153.30
505			Pender Booster Club	-383.76	0.00	0.00	0.00	-383.76
510			CONCESSIONS	44,291.44	1,258.10	29.68	0.00	45,519.86
525			INTEREST	-82,274.02	45.77	0.00	0.00	-82,228.25
530			FLAMES	765.98	350.00	0.00	0.00	1,115.98
535			PENDER POP MACHINE	25,892.42	446.40	0.00	0.00	26,338.82
540			PICTURE MONEY	4,287.18	0.00	0.00	0.00	4,287.18
580			CM Science Day	1,119.17	0.00	0.00	0.00	1,119.17
585			ART	836.59	0.00	0.00	0.00	836.59
620			ACTIVITY FEES	4,500.00	0.00	0.00	0.00	4,500.00
777			E-Sports	-355.11	0.00	0.00	0.00	-355.11
E Totals:				17,945.95	17,550.25	4,517.24	-255.52	30,723.44
F VOCATIONAL ORGANIZATIONS								
606			FFA LEADERSHIP	38,480.35	0.00	1,304.00	0.00	37,176.35
610			FFA	64,463.15	0.00	157.00	0.00	64,306.15
615			FFA INSTRUCTOR	-10,857.41	0.00	0.00	0.00	-10,857.41
F Totals:				92,086.09	0.00	1,461.00	0.00	90,625.09

Current Cash Balance

Sorted by Site ID, Group ID, Activity ID.
From 08/01/2023 to 08/31/2023.

Site ID Group ID	Site Name Group Name	Activity ID	Activity Name	Beginning Cash	Receipts	Disbursements	Adjustments	Cash Balance	
G ADMINISTRATION									
700			HOSTED CONTEST	40,674.58	0.00	1,980.00	0.00	38,694.58	
705			STAFF DEVELOPMENT	-4,131.74	0.00	0.00	0.00	-4,131.74	
710			STATE CONTEST	-28,845.36	0.00	0.00	0.00	-28,845.36	
715			EQUIPMENT	-21,108.74	0.00	0.00	0.00	-21,108.74	
720			MISCELLANEOUS	-19,451.18	0.00	2,000.00	0.00	-21,451.18	
G Totals:				-32,862.44	0.00	3,980.00	0.00	-36,842.44	
H INVESTMENTS									
1010			CERTIFICATES OF DEPOSIT	52,894.69	0.00	0.00	0.00	52,894.69	
1020			INTEREST ON CD'S	25,782.77	0.00	0.00	0.00	25,782.77	
H Totals:				78,677.46	0.00	0.00	0.00	78,677.46	
I CO-OP ACTIVITIES									
2005			Raptor JH VB	-903.18	0.00	0.00	0.00	-903.18	
2010			Raptor JH Football	-4,166.49	0.00	0.00	0.00	-4,166.49	
2015			Raptors JH Girls Basketball	174.32	0.00	0.00	0.00	174.32	
2020			Raptors JH Boys Basketball	-528.42	0.00	0.00	0.00	-528.42	
2025			Raptors JH Wrestling	-3,168.58	0.00	0.00	0.00	-3,168.58	
2030			Raptors JH Track	-2,342.03	0.00	0.00	0.00	-2,342.03	
905			Raptor HS Track	-6,038.52	0.00	0.00	0.00	-6,038.52	
915			TC Thunder Bowling	-486.00	0.00	0.00	0.00	-486.00	
925			Thunder Baseball	1,826.79	0.00	0.00	0.00	1,826.79	
975			Raptor Speech	-120.00	0.00	0.00	0.00	-120.00	
985			Softball Co-op	-8,702.26	595.00	1,112.72	0.00	-9,219.98	
I Totals:				-24,454.37	595.00	1,112.72	0.00	-24,972.09	
PPS Activity Totals:				144,002.47	33,322.65	20,604.14	-255.52	156,465.46	
<hr/>									
			Begin Balance	65,357.67	0.00	33,322.65	20,604.14	-255.52	77,820.66
			PPS Checking:	65,357.67	0.00	33,322.65	20,604.14	-255.52	77,820.66
			PPS Investment:	78,644.80	0.00		0.00		78,644.80
			PPS Bank Balances:	144,002.47	33,322.65	20,604.14	-255.52		156,465.46
<hr/>									
Report Activity Totals:				144,002.47	33,322.65	20,604.14	-255.52	156,465.46	

Check Detail

Sorted by Activity ID, Site ID.
From 08/01/2023 to 08/31/2023.

Activity ID	Activity Name	Site ID	Site Name	Check #	Issue Date	Vendor Name	Approved by					Amount
Status	Status Date	PO Number	1099?	Invoice Number	Description							
110	BOYS BASKETBALL											
PPS	Pender Public Schools											
044952	08/21/2023	Hudl				Deanna Hansen						
Printed	08/21/2023		No	H00029724	annual renewal							500.00

Check Detail

Sorted by Activity ID, Site ID.
From 08/01/2023 to 08/31/2023.

Activity ID Site ID Check # Status	Activity Name Site Name Issue Date Status Date	Vendor Name PO Number	1099?	Invoice Number	Approved by Description	Amount
120	FOOTBALL					
PPS	Pender Public Schools					
044931 Void	08/14/2023 08/15/2023	First National Bank of Omaha	No	8/23-4874-Volk	Deanna Hansen football	66.30
044931 Void	08/14/2023 08/15/2023	First National Bank of Omaha 867911	No	8/23-4784-Volk.2	Deanna Hansen mouthpieces for football	86.38
044931 Void	08/14/2023 08/15/2023	First National Bank of Omaha	No	8/23-4874-Volk	Deanna Hansen football	-66.30
044931 Void	08/14/2023 08/15/2023	First National Bank of Omaha 867911	No	8/23-4784-Volk.2	Deanna Hansen mouthpieces for football	-86.38
044933 Void	08/14/2023 08/15/2023	Hauff Mid-America Sports 867903	No	126920	Deanna Hansen Football practice gear (players paid)	-2,170.00
044933 Void	08/14/2023 08/15/2023	Hauff Mid-America Sports 867903	No	126920	Deanna Hansen Football practice gear (players paid)	-68.30
044933 Void	08/14/2023 08/15/2023	Hauff Mid-America Sports 867903	No	126920	Deanna Hansen Football practice gear (players paid)	2,170.00
044933 Void	08/14/2023 08/15/2023	Hauff Mid-America Sports 867903	No	126920	Deanna Hansen Football practice gear (players paid)	68.30
044937 Void	08/14/2023 08/18/2023	Porta Phone 867910	No	23PP3234	Deanna Hansen Football headset	471.47
044937 Void	08/14/2023 08/18/2023	Porta Phone 867910	No	23PP3234	Deanna Hansen Football headset	-471.47
044940 Void	08/14/2023 08/18/2023	US Specialty Coatings	No	242635	Deanna Hansen field paint	-495.85
044940 Void	08/14/2023 08/18/2023	US Specialty Coatings	No	242635	Deanna Hansen field paint	495.85
044944 Cleared	08/15/2023 08/31/2023	First National Bank of Omaha 867911	No	8/23-4784-Volk.2	Deanna Hansen mouthpieces for football	86.38
044944 Cleared	08/15/2023 08/31/2023	First National Bank of Omaha	No	8/23-4874-Volk	Deanna Hansen ipad film storage	66.30
044946 Cleared	08/15/2023 08/31/2023	Hauff Mid-America Sports 867903	No	126920	Deanna Hansen practice gear for players	2,170.00
044946 Cleared	08/15/2023 08/31/2023	Hauff Mid-America Sports 867903	No	126920	Deanna Hansen practice gear for players	68.30
044950 Cleared	08/21/2023 08/31/2023	Donica Heineman	No	82125fb	Deanna Hansen refund for FB jersey	100.00

Check Detail

Sorted by Activity ID, Site ID.
From 08/01/2023 to 08/31/2023.

Activity ID	Activity Name	Site ID	Site Name	Check #	Issue Date	Vendor Name	Approved by	Amount
Status	Status Date	PO Number	1099?	Invoice Number	Description			
120	FOOTBALL							

044952	08/21/2023	Hudl				Deanna Hansen		
Printed	08/21/2023		No	H00029724		annual renewal		500.00
044958	08/21/2023	Porta Phone				Deanna Hansen		
Printed	08/21/2023	867910	No	23PP3234		Football headset		471.47
044962	08/21/2023	US Specialty Coatings				Deanna Hansen		
Cleared	08/31/2023		No	242635		field striping paint		495.85

Check Detail

Sorted by Activity ID, Site ID.
From 08/01/2023 to 08/31/2023.

Activity ID Site ID Check # Status	Activity Name Site Name Issue Date Status Date	Vendor Name PO Number	1099?	Invoice Number	Approved by Description	Amount
120	FOOTBALL					
PPS	Pender Public Schools					
044969 Cleared	08/24/2023 08/31/2023	Gary Eikmeier	Yes	82423fb	Deanna Hansen 8/25 FB vs Elkhorn Valley	125.00
044970 Cleared	08/24/2023 08/31/2023	Mitchell Schweers	Yes	82423fb	Deanna Hansen 8/25 FB vs Elkhorn Valley	125.00
044971 Printed	08/24/2023 08/24/2023	Shawn Grovijohn	No	82423fb	Deanna Hansen 8/25 FB vs Elkhorn Valley	125.00
044972 Cleared	08/24/2023 08/31/2023	Tim Wobken	No	82423fb	Deanna Hansen 8/25 FB vs Elkhorn Valley	125.00
044973 Printed	08/24/2023 08/24/2023	Tom Grovijohn	Yes	82423fb	Deanna Hansen 8/25 FB vs Elkhorn Valley	125.00
044975 Cleared	08/28/2023 08/31/2023	Anthony Bonneau	Yes	82823jvfb	Deanna Hansen 8/28 JV FB vs Randolph	65.00
044976 Printed	08/28/2023 08/28/2023	Andy Welsh	Yes	82823jvfb	Deanna Hansen 8/28 JV FB vs Randolph	65.00
044977 Printed	08/28/2023 08/28/2023	Matt Torczon	Yes	82823jvfb	Deanna Hansen 8/28 JV FB vs Randolph	65.00
044978 Cleared	08/28/2023 08/31/2023	Mitchell Mailloux	No	82823jvfb	Deanna Hansen 8/28 JV FB vs Randolph	65.00
Total for PPS - Pender Public Schools:						4,843.30
Total for 120 - FOOTBALL:						4,843.30

125	GIRLS BASKETBALL					
PPS	Pender Public Schools					
044952 Printed	08/21/2023 08/21/2023	Hudl	No	H00029724	Deanna Hansen annual renewal	500.00

Check Detail

Sorted by Activity ID, Site ID.
From 08/01/2023 to 08/31/2023.

Activity ID Site ID Check # Status	Activity Name Site Name Issue Date Status Date	Vendor Name PO Number	1099?	Invoice Number	Approved by Description	Amount
<hr/> 135 HS TRACK <hr/>						
PPS	Pender Public Schools					
044933 Void	08/14/2023 08/15/2023	Hauff Mid-America Sports	No	122625	Deanna Hansen shipping	13.31
044933 Void	08/14/2023 08/15/2023	Hauff Mid-America Sports	No	122625	Deanna Hansen shipping	-13.31
044946 Cleared	08/15/2023 08/31/2023	Hauff Mid-America Sports	No	122625	Deanna Hansen shipping	13.31
044957 Cleared	08/21/2023 08/31/2023	Port-A-Johns	No	23-3285	Deanna Hansen portable restrooms	75.00
Total for PPS - Pender Public Schools:						88.31
Total for 135 - HS TRACK:						88.31

<hr/> 165 VOLLEYBALL <hr/>						
PPS	Pender Public Schools					
044932 Void	08/14/2023 08/15/2023	Graffix Inc. 867913	No	151847	Deanna Hansen Youth Camp T-Shirts	536.07
044932 Void	08/14/2023 08/15/2023	Graffix Inc. 867913	No	151847	Deanna Hansen Youth Camp T-Shirts	-536.07
044945 Cleared	08/15/2023 08/31/2023	Graffix Inc. 867913	No	151847	Deanna Hansen Youth Camp T-Shirts	536.07
044952 Printed	08/21/2023 08/21/2023	Hudl	No	H00029724	Deanna Hansen annual renewal	500.00
044963 Cleared	08/21/2023 08/31/2023	Keena Koehlmoos	Yes	82123vb	Deanna Hansen VB scrimmage ref	75.00
044964 Cleared	08/21/2023 08/31/2023	Traci Krusemark	No	82123vb	Deanna Hansen VB scrimmage ref	75.00
044980 Printed	08/29/2023 08/29/2023	Dawn Oswald	Yes	82923vb	Deanna Hansen 8/29 VB vs Logan View	150.00
044981 Printed	08/29/2023 08/29/2023	Timarie A. Bebee-Hansen	Yes	82923vb	Deanna Hansen 8/29 VB vs Logan View	150.00
Total for PPS - Pender Public Schools:						1,486.07
Total for 165 - VOLLEYBALL:						1,486.07

Check Detail

Sorted by Activity ID, Site ID.
From 08/01/2023 to 08/31/2023.

Activity ID Site ID Check # Status	Activity Name Site Name Issue Date Status Date	Vendor Name PO Number	1099?	Invoice Number	Approved by Description	Amount
<hr/> 182 BASEBALL <hr/>						
PPS	Pender Public Schools					
044929 Void	08/14/2023 08/15/2023	AT&T Mobility	No	287312820239X 07282023	Deanna Hansen Legion BB hotspot	-40.04
044929 Void	08/14/2023 08/15/2023	AT&T Mobility	No	287312820239X 07282023	Deanna Hansen Legion BB hotspot	40.04
044942 Cleared	08/15/2023 08/31/2023	AT&T Mobility	No	287312820239X 07282023	Deanna Hansen Legion BB hotspot	40.04
Total for PPS - Pender Public Schools:						40.04
Total for 182 - BASEBALL:						40.04

<hr/> 185 CROSS COUNTRY <hr/>						
PPS	Pender Public Schools					
044930 Void	08/14/2023 08/15/2023	Awards Unlimited, Inc.	No	76317	Deanna Hansen XC & Battle of Bands trophies	-360.19
044930 Void	08/14/2023 08/15/2023	Awards Unlimited, Inc.	No	76317	Deanna Hansen XC & Battle of Bands trophies	360.19
044940 Void	08/14/2023 08/18/2023	US Specialty Coatings	No	242635	Deanna Hansen field paint	495.85
044940 Void	08/14/2023 08/18/2023	US Specialty Coatings	No	242635	Deanna Hansen field paint	-495.85
044943 Printed	08/15/2023 08/15/2023	Awards Unlimited, Inc.	No	76317	Deanna Hansen XC & Battle of Bands trophies	360.19
044962 Cleared	08/21/2023 08/31/2023	US Specialty Coatings	No	242635	Deanna Hansen field striping paint	495.85
044974 Printed	08/24/2023 08/24/2023	Wisner-Pilger High School	No	82423xc	Deanna Hansen 8/31/23 Cross Country fee	100.00
Total for PPS - Pender Public Schools:						956.04
Total for 185 - CROSS COUNTRY:						956.04

Check Detail

Sorted by Activity ID, Site ID.
From 08/01/2023 to 08/31/2023.

Activity ID Site ID Check # Status	Activity Name Site Name Issue Date Status Date	Vendor Name PO Number	1099?	Invoice Number	Approved by Description	Amount
<hr/> 294 Class of 2025 <hr/>						
PPS Pender Public Schools						
044900 Void	06/19/2023 08/05/2023	Pender-Thurston Chamber of Commerce 867904	No	61923flyin	Deanna Hansen Deposit to borrow pancake cookers	-75.00
044935 Void	08/14/2023 08/18/2023	Pender School Nutrition Fund	No	06262023	Deanna Hansen flyin breakfast	-627.34
044935 Void	08/14/2023 08/18/2023	Pender School Nutrition Fund	No	06262023	Deanna Hansen flyin breakfast	627.34
044956 Cleared	08/21/2023 08/31/2023	Pender School Nutrition Fund	No	06262023	Deanna Hansen supplies for flyin breakfast	627.34
Total for PPS - Pender Public Schools:						552.34
Total for 294 - Class of 2025:						552.34
<hr/> 315 INSTRUMENTAL <hr/>						
PPS Pender Public Schools						
044930 Void	08/14/2023 08/15/2023	Awards Unlimited, Inc.	No	76317	Deanna Hansen XC & Battle of Bands trophies	42.08
044930 Void	08/14/2023 08/15/2023	Awards Unlimited, Inc.	No	76317	Deanna Hansen XC & Battle of Bands trophies	-42.08
044943 Printed	08/15/2023 08/15/2023	Awards Unlimited, Inc.	No	76317	Deanna Hansen XC & Battle of Bands trophies	42.08
Total for PPS - Pender Public Schools:						42.08
Total for 315 - INSTRUMENTAL:						42.08
<hr/> 335 NATIONAL HONOR SOCIETY <hr/>						
PPS Pender Public Schools						
044959 Printed	08/21/2023 08/21/2023	Roxy Ekberg	No	82123nhs	Deanna Hansen 2023 NHS scholarship	125.00

Check Detail

Sorted by Activity ID, Site ID.
From 08/01/2023 to 08/31/2023.

Activity ID Site ID Check # Status	Activity Name Site Name Issue Date Status Date	Vendor Name PO Number	1099?	Invoice Number	Approved by Description	Amount
<hr/> 445 MISCELLANEOUS <hr/>						
PPS	Pender Public Schools					
044936 Void	08/14/2023 08/18/2023	Port-A-Johns	No	23-3285	Deanna Hansen portable restrooms	75.00
044936 Void	08/14/2023 08/18/2023	Port-A-Johns	No	23-3285	Deanna Hansen portable restrooms	-75.00
044949 Cleared	08/21/2023 08/31/2023	Custom Sports	No	35896	Deanna Hansen Pender Clothing for Open House	4,245.00
044968 Cleared	08/24/2023 08/31/2023	Leigh community Schools	No	082423ehc	Deanna Hansen 2023 EHC Mtg meals	120.00
044993 Printed	08/31/2023 08/31/2023	Pender School Nutrition Fund	No	83123clothes	Deanna Hansen \$50 Dana Beckman	50.00
044993 Printed	08/31/2023 08/31/2023	Pender School Nutrition Fund	No	83123clothes	Deanna Hansen \$47 Gina Dutcher	47.00
Total for PPS - Pender Public Schools:						4,462.00
Total for 445 - MISCELLANEOUS:						4,462.00

<hr/> 450 F&R Sponsor Pd by District <hr/>						
PPS	Pender Public Schools					
044931 Void	08/14/2023 08/15/2023	First National Bank of Omaha	No	8/23-4874-Volk	Deanna Hansen football	-25.56
044931 Void	08/14/2023 08/15/2023	First National Bank of Omaha	No	8/23-4874-Volk	Deanna Hansen football	25.56
044944 Cleared	08/15/2023 08/31/2023	First National Bank of Omaha	No	8/23-4874-Volk	Deanna Hansen ipad film storage	25.56
Total for PPS - Pender Public Schools:						25.56
Total for 450 - F&R Sponsor Pd by District:						25.56

Check Detail

Sorted by Activity ID, Site ID.
From 08/01/2023 to 08/31/2023.

Activity ID Site ID Check # Status	Activity Name Site Name Issue Date Status Date	Vendor Name PO Number	1099?	Invoice Number	Approved by Description	Amount
510 CONCESSIONS						
PPS	Pender Public Schools					
044939 Void	08/14/2023 08/18/2023	Sam's Club	No	10088225549	Deanna Hansen towels for concession stand	29.68
044939 Void	08/14/2023 08/18/2023	Sam's Club	No	10088225549	Deanna Hansen towels for concession stand	-29.68
044961 Printed	08/21/2023 08/21/2023	Sam's Club	No	82123conc	Deanna Hansen Order #10088225549	29.68
Total for PPS - Pender Public Schools:						29.68
Total for 510 - CONCESSIONS:						29.68

606 FFA LEADERSHIP						
PPS	Pender Public Schools					
044928 Void	08/14/2023 08/15/2023	Allie Luedert	No	08142023ffa	Deanna Hansen Kaser Scholarship	300.00
044928 Void	08/14/2023 08/15/2023	Allie Luedert	No	08142023ffa	Deanna Hansen Kaser Scholarship	-300.00
044938 Void	08/14/2023 08/18/2023	Rylie Bonneau	No	08142023ffa	Deanna Hansen Kaser Scholarship	-300.00
044938 Void	08/14/2023 08/18/2023	Rylie Bonneau	No	08142023ffa	Deanna Hansen Kaser Scholarship	300.00
044941 Printed	08/15/2023 08/15/2023	Allie Luedert	No	8152023ffa	Deanna Hansen Kaser Scholarship	300.00
044947 Printed	08/21/2023 08/21/2023	Big Shots 867919	No	Aug16,2023	Deanna Hansen Trophy Cases	400.00
044954 Cleared	08/21/2023 08/31/2023	National FFA Organization	No	1073534	Deanna Hansen new member signs and letters	304.00
044960 Cleared	08/21/2023 08/31/2023	Rylie Bonneau	No	82123ffa	Deanna Hansen 2023 Kaser Scholarship	300.00
Total for PPS - Pender Public Schools:						1,304.00
Total for 606 - FFA LEADERSHIP:						1,304.00

610 FFA						
PPS	Pender Public Schools					
044954 Cleared	08/21/2023 08/31/2023	National FFA Organization 867846	No	1070366	Deanna Hansen FFA Jacket, etc	157.00

Check Detail

Sorted by Activity ID, Site ID.
From 08/01/2023 to 08/31/2023.

Activity ID Site ID Check # Status	Activity Name Site Name Issue Date Status Date	Vendor Name PO Number	1099?	Invoice Number	Approved by Description	Amount
700 HOSTED CONTEST						
PPS	Pender Public Schools					
044984 Printed	08/31/2023 08/31/2023	Brad Hoskins	Yes	83123nenvb	Deanna Hansen 8/31 NE NE VB tourney official	165.00
044985 Printed	08/31/2023 08/31/2023	Carol Manganaro	Yes	83123nenvb	Deanna Hansen 8/31 NE NE VB tourney official	165.00
044986 Printed	08/31/2023 08/31/2023	Keena Koehlmoos	Yes	83123nenvb	Deanna Hansen 8/31 NE NE VB tourney official	165.00
044987 Printed	08/31/2023 08/31/2023	Tom Nitzschke	Yes	83123nenvb	Deanna Hansen 8/31 NE NE VB tourney official	165.00
044988 Printed	08/31/2023 08/31/2023	Elizabeth Maertins	Yes	83123nenvb	Deanna Hansen 9/2 NE NE VB tourney official	330.00
044989 Printed	08/31/2023 08/31/2023	Carol Manganaro	Yes	83123nenvb	Deanna Hansen 9/2 NE NE VB tourney official	330.00
044990 Printed	08/31/2023 08/31/2023	Curtis Maertins	Yes	83123nenvb	Deanna Hansen 9/2 NE NE VB tourney official	330.00
044991 Printed	08/31/2023 08/31/2023	Tom Nitzschke	Yes	83123nenvb	Deanna Hansen 9/2 NE NE VB tourney official	330.00
Total for PPS - Pender Public Schools:						1,980.00
Total for 700 - HOSTED CONTEST:						1,980.00

720 MISCELLANEOUS						
PPS	Pender Public Schools					
044927 Cleared	08/10/2023 08/31/2023	Frontier Bank	No		Deanna Hansen cash boxes	2,000.00

Check Detail

Sorted by Activity ID, Site ID.
From 08/01/2023 to 08/31/2023.

Activity ID Site ID Check # Status	Activity Name Site Name Issue Date Status Date	Vendor Name PO Number	1099?	Invoice Number	Approved by Description	Amount
<hr/>						
950	Girls Golf Coop					
<hr/>						
PPS	Pender Public Schools					
044965 Printed	08/21/2023 08/21/2023	West Point-Beemer Community Schools	No	8/21/23gg	Deanna Hansen 8/18/23 Girls Golf fee	100.00
044966 Printed	08/21/2023 08/21/2023	Stanton Community School	No	8/21/23gg	Deanna Hansen 8/31/23 Girls Golf fee	125.00
044967 Printed	08/21/2023 08/21/2023	Wayne Community Schools	No	8/21/23gg	Deanna Hansen 8/25/23 Girls Golf fee	110.00
044992 Printed	08/31/2023 08/31/2023	Pierce Public School	No	83123gg	Deanna Hansen 9/9 Girls Golf fee	65.00
Total for PPS - Pender Public Schools:						400.00
Total for 950 - Girls Golf Coop:						400.00
<hr/>						
985	Softball Co-op					
<hr/>						
PPS	Pender Public Schools					
044934 Void	08/14/2023 08/18/2023	Pender Ace Hardware	No	44861	Deanna Hansen field striping paint	43.96
044934 Void	08/14/2023 08/18/2023	Pender Ace Hardware	No	44861	Deanna Hansen field striping paint	-43.96
044948 Cleared	08/21/2023 08/31/2023	Craig Hanneman	Yes	81723sb	Deanna Hansen 8/17 SB vs Neuman	140.00
044951 Cleared	08/21/2023 08/31/2023	Hauff Sports Omaha 867918	No	129360	Deanna Hansen team shirts	298.76
044953 Cleared	08/21/2023 08/31/2023	Mark Groth	Yes	81423sb	Deanna Hansen 8/17 SB vs Neuman	140.00
044955 Cleared	08/21/2023 08/31/2023	Pender Ace Hardware	No	044861	Deanna Hansen field striping paint	43.96
044979 Cleared	08/28/2023 08/31/2023	Mike Fleer	Yes	82823sb	Deanna Hansen 8/28 JV SB vs Cuming County	70.00
044982 Printed	08/29/2023 08/29/2023	Craig Hanneman	Yes	82923sb	Deanna Hansen 8/31 SB vs T-H & Cuming County	210.00
044983 Printed	08/29/2023 08/29/2023	Dan Meister	Yes	82923sb	Deanna Hansen 8/31 SB vs T-H & Cuming County	210.00
Total for PPS - Pender Public Schools:						1,112.72
Total for 985 - Softball Co-op:						1,112.72
Grand Total :						20,604.14

Receipt History

Detail report. Sorted by Site, Receipt Number.
From 08/01/2023 to 08/31/2023.

Receipt Number	Receipt Date	Void Date	Deposit Number	Check Number	Received From	Receipt Description	Amount	Sales Tax	Amount
Activity ID	Activity Name		Fee Name & Student ID				Tax Amount		
Tax Name	Tax Activity			Tax Rate %					
PPS Pender Public Schools									
002933	08/02/2023		8-2-2023		parents	youth volleyball camp			
165	VOLLEYBALL						150.00	0.00	150.00
									150.00
002934	08/02/2023		8-2-2023		parents	dance camp fees			
530	FLAMES						300.00	0.00	300.00
									300.00
002935	08/08/2023		8-8-2023		parents	dance camp reg fees			
530	FLAMES						50.00	0.00	50.00
									50.00
002936	08/08/2023		8-8-2023		parents	youth vb camp reg fees			
165	VOLLEYBALL						90.00	0.00	90.00
									90.00
002937	08/08/2023		8-8-2023		Hauff Sports	FB clothing sale proceeds			
120	FOOTBALL						564.00	0.00	564.00
									564.00
002938	08/09/2023		8-9-2023		golfers/parents	BG champion rings			
115	BOYS GOLF						1,904.00	0.00	1,904.00
									1,904.00
002939	08/14/2023		8-14-2023		American Legion	closeup receipts			
365	CLOSE-UP						400.00	0.00	400.00
									400.00
002940	08/14/2023		8-14-2023		Gralheer	yearbook sales			
375	YEARBOOK						40.00	0.00	40.00
									40.00
002941	08/22/2023		8-23-23		PPS General Fund	22-23 F/R reimburse from GF			
450	F&R Sponsor Pd by District						11,683.98	0.00	11,683.98
									11,683.98
002942	08/22/2023		8-23-23		Felber	GBB champion ring			
125	GIRLS BASKETBALL						225.50	0.00	225.50
									225.50
002943	08/22/2023		8-23-23		community members	activity passes			
197	ADVANCE TICKET SALES						2,930.00	0.00	2,930.00
									2,930.00
002944	08/22/2023		8-23-23		Thriftique	donation for speaker			
315	INSTRUMENTAL						1,000.00	0.00	1,000.00
									1,000.00
002945	08/22/2023		8-23-23		Thriftique	grant for care closet			
455	Care Closet						1,500.00	0.00	1,500.00
									1,500.00
002946	08/22/2023		8-23-23		community members	clothing sales			
445	MISCELLANEOUS						1,581.00	0.00	1,581.00

Receipt History

Detail report. Sorted by Site, Receipt Number.
From 08/01/2023 to 08/31/2023.

Receipt Number	Receipt Date	Void Date	Deposit Number	Check Number	Received From	Receipt Description	Amount	Sales Tax	Amount
Activity ID	Activity Name		Fee Name & Student ID				Amount	Tax Amount	Amount
Tax Name	Tax Activity						Tax Amount		
Total For 002946:							1,581.00		
002947	08/22/2023		8-23-23		spectators	gate-SB vs Bishop Neuman			
985	Softball Co-op						355.00	0.00	355.00
Total For 002947:							355.00		
002948	08/22/2023		8-23-23		parents	photo sales			
375	YEARBOOK						250.00	0.00	250.00
Total For 002948:							250.00		
002949	08/22/2023		8-23-23		parents	photo sales			
375	YEARBOOK						239.50	0.00	239.50
Total For 002949:							239.50		
002950	08/22/2023		8-23-23		community members	activity pass			
197	ADVANCE TICKET SALES						40.00	0.00	40.00
Total For 002950:							40.00		
002951	08/22/2023		8-23-23		C Webster	donation			
985	Softball Co-op						90.00	0.00	90.00
Total For 002951:							90.00		
002952	08/23/2023		8-23-23		Ballinger	speech/softball			
321	Speech						50.00	0.00	50.00
985	Softball Co-op						50.00	0.00	50.00
Total For 002952:							100.00		
002953	08/25/2023		8-25-2023		Kelly Ballinger	reimbursement-KBSam			
321	Speech						50.00	0.00	50.00
Total For 002953:							50.00		
002954	08/25/2023		8-25-2023		community members	Activity Passes			
197	ADVANCE TICKET SALES						442.00	0.00	442.00
Total For 002954:							442.00		
002955	08/25/2023		8-25-2023		community members	softball donation			
985	Softball Co-op						100.00	0.00	100.00
Total For 002955:							100.00		
002956	08/25/2023		8-25-2023		parents	photo sales			
375	YEARBOOK						99.00	0.00	99.00
Total For 002956:							99.00		
002957	08/25/2023		8-25-2023		community members	photo sales			
375	YEARBOOK						324.00	0.00	324.00
Total For 002957:							324.00		
002958	08/26/2023		8-26-2023		community members	Pender Clothing sales			
445	MISCELLANEOUS						134.00	0.00	134.00
Total For 002958:							134.00		
002959	08/26/2023		8-26-2023		Bad Sportz	profit/VB clothing sales			
165	VOLLEYBALL						690.00	0.00	690.00
Total For 002959:							690.00		
002960	08/26/2023		8-26-2023		Deanna Hansen	concessions-pop			

Receipt History

Detail report. Sorted by Site, Receipt Number.
From 08/01/2023 to 08/31/2023.

Receipt Number	Receipt Date	Void Date	Deposit Number	Check Number	Received From	Amount	Sales Tax	Amount
Activity ID	Activity Name		Fee Name & Student ID			Tax Amount		
	Tax Name		Tax Activity	Tax Rate %				
510	CONCESSIONS					35.00	0.00	35.00
						Total For 002960:		35.00
002961	08/26/2023		8-26-2023		community members			Activity Passes
197	ADVANCE TICKET SALES					610.00	0.00	610.00
						Total For 002961:		610.00
002962	08/28/2023		8-28-2023		community members			student council yardline sales
345	STUDENT COUNCIL					1,200.00	0.00	1,200.00
						Total For 002962:		1,200.00
002963	08/28/2023		8-28-2023		staff members			Pender clothing sales
445	MISCELLANEOUS					491.00	0.00	491.00
						Total For 002963:		491.00
002964	08/28/2023		8-28-2023		spectators			gate-FB vs elkhorn valley
120	FOOTBALL					1,050.00	0.00	1,050.00
						Total For 002964:		1,050.00
002965	08/28/2023		8-28-2023		staff and students			vending proceeds
535	PENDER POP MACHINE					446.40	0.00	446.40
						Total For 002965:		446.40
002966	08/28/2023		8-28-2023		spectators			conc-FB vs Elkhorn Valley
510	CONCESSIONS					645.60	0.00	645.60
365	CLOSE-UP					430.40	0.00	430.40
						Total For 002966:		1,076.00
002967	08/30/2023		8-30-2023		spectators			conc-VB vs Logan View
510	CONCESSIONS					390.60	0.00	390.60
115	BOYS GOLF					260.40	0.00	260.40
						Total For 002967:		651.00
002968	08/30/2023		8-30-2023		parents			youth FB camp reg fees
120	FOOTBALL					440.00	0.00	440.00
						Total For 002968:		440.00
002969	08/30/2023		8-30-2023		community members			Activity Passes
197	ADVANCE TICKET SALES					330.00	0.00	330.00
						Total For 002969:		330.00
002970	08/30/2023		8-30-2023		spectators			conc-JV FB vs Randolph
510	CONCESSIONS					186.90	0.00	186.90
125	GIRLS BASKETBALL					124.60	0.00	124.60
						Total For 002970:		311.50
002971	08/30/2023		8-30-2023		community members			activity passes
197	ADVANCE TICKET SALES					270.00	0.00	270.00
						Total For 002971:		270.00
002972	08/30/2023		8-30-2023		spectators			gate-VB vs Logan View
165	VOLLEYBALL					260.00	0.00	260.00
						Total For 002972:		260.00
002973	08/30/2023		8-30-2023		spectators			gate-JV FB vs Randolph
120	FOOTBALL					250.00	0.00	250.00

Receipt History

Detail report. Sorted by Site, Receipt Number.
From 08/01/2023 to 08/31/2023.

Receipt Number	Receipt Date	Void Date	Deposit Number	Check Number	Received From	Receipt Description	Amount	Sales Tax	Amount
Activity ID	Activity Name		Fee Name & Student ID				Amount	Tax Amount	Amount
	Tax Name		Tax Activity				Amount	Tax Amount	Amount
Total For 002973:									250.00
002974	08/30/2023		8-30-2023		parents	photo sales			
375	YEARBOOK						24.00	0.00	24.00
Total For 002974:									24.00
002975	08/30/2023		8-30-2023		staff	Pender clothing sales			
445	MISCELLANEOUS						60.00	0.00	60.00
Total For 002975:									60.00
002976	08/30/2023		8-30-2023		community members	Activity Passes			
197	ADVANCE TICKET SALES						160.00	0.00	160.00
Total For 002976:									160.00
002977	08/31/2023		8-31-2023 #2		frontier bank	checking acct interest			
525	INTEREST						45.77	0.00	45.77
Total For 002977:									45.77
002978	08/31/2023		8-31-2023 #2		community members via	activity passes			
197	ADVANCE TICKET SALES						280.00	0.00	280.00
Total For 002978:									280.00
Site Total									33,322.65
Report Total									33,322.65

Actual Bank Balances as of August 31, 2023

	Fund	Balance	
	General Fund	1,661,143.69	Actual
	Depreciation Fund	184,727.62	Actual
	Employee Benefit Fund	183,775.87	Actual
	School Nutrition Fund	144,679.47	Actual
	Bond Fund	48,771.20	Actual
	Special Building Fund	1,069,079.49	Actual
	Qualified Capital Purpose Undertaking Fund	44,645.83	Actual
	Student Fee Fund	43.31	Actual
	Petty Cash Fund	1,124.00	Actual
	Activity Fund	156,465.46	Actual
	TOTAL		3,494,455.94

Pender Municipal Utility Bills/Averages

Year	Month	Natural Gas	Electricity	FB Elec/Water	Water/Sewer	Total
2023	January	\$ 4,718.83	\$ 8,192.30	\$ 160.55	\$ 290.29	\$ 13,361.97
2023	February	\$ 3,695.79	\$ 10,265.66	\$ 162.63	\$ 413.65	\$ 14,537.73
2023	March	\$ 8,474.60	\$ 7,757.32	\$ 199.46	\$ 275.05	\$ 16,706.43
2023	April	\$ 2,212.75	\$ 11,056.43	\$ 1,000.15	\$ 374.43	\$ 14,643.76
2023	May	\$ 1,043.77	\$ 12,075.52	\$ 1,343.01	\$ 317.39	\$ 14,779.69
2023	June	\$ 681.42	\$ 13,357.99	\$ 1,459.13	\$ 249.85	\$ 15,748.39
2023	July	\$ 969.11	\$ 12,710.30	\$ 1,569.31	\$ 247.43	\$ 15,496.15
2023	August	\$ 950.09	\$ 15,089.12	\$ 718.67	\$ 268.73	\$ 17,026.61
2023	September					\$ -
2023	October					\$ -
2023	November					\$ -
2023	December					\$ -
2023	TOTAL	\$ 22,746.36	\$ 90,504.64	\$ 6,612.91	\$ 2,436.82	\$ 122,300.73
2023	MO. AVERAGE	\$ 2,843.30	\$ 11,313.08	\$ 826.61	\$ 304.60	\$ 15,287.59
Year	Month	Natural Gas	Electricity	FB Elec/Water	Water/Sewer	Total
2022	January	\$ -	\$ 8,777.18	\$ 120.25	\$ 332.89	\$ 9,230.32
2022	February	\$ -	\$ 9,597.06	\$ 120.25	\$ 377.09	\$ 10,094.40
2022	March	\$ 1,215.93	\$ 8,917.77	\$ 120.25	\$ 377.05	\$ 10,631.00
2022	April	\$ 2,678.22	\$ 9,604.55	\$ 120.25	\$ 364.95	\$ 12,767.97
2022	May	\$ 1,711.88	\$ 11,861.38	\$ 120.25	\$ 566.94	\$ 14,260.45
2022	June	\$ 1,869.69	\$ 13,652.51	\$ 110.97	\$ 465.42	\$ 16,098.59
2022	July	\$ 1,419.76	\$ 13,750.49	\$ 392.56	\$ 201.52	\$ 15,764.33
2022	August	\$ 1,599.23	\$ 14,104.83	\$ 244.52	\$ 262.94	\$ 16,211.52
2022	September	\$ 1,074.73	\$ 15,148.59	\$ 120.25	\$ 389.79	\$ 16,733.36
2022	October	\$ 1,720.93	\$ 10,626.04	\$ 308.86	\$ 311.33	\$ 12,967.16
2022	November	\$ 4,174.33	\$ 11,008.94	\$ 161.28	\$ 353.94	\$ 15,698.49
2022	December	\$ 6,327.96	\$ 8,878.96	\$ 162.02	\$ 322.64	\$ 15,691.58
2022	TOTAL	\$ 23,792.66	\$ 135,928.30	\$ 2,101.71	\$ 4,326.50	\$ 166,149.17
2022	MO. AVERAGE	\$ 1,982.72	\$ 11,327.36	\$ 175.14	\$ 360.54	\$ 13,845.76
2021	January	\$ 3,957.78	\$ 8,355.79		\$ 621.06	\$ 12,934.63
2021	February	\$ 25,194.50	\$ 8,679.26		\$ 405.43	\$ 34,279.19
2021	March	\$ 2,092.81	\$ 7,457.02		\$ 407.77	\$ 9,957.60
2021	April	\$ 1,433.47	\$ 8,274.42		\$ 415.93	\$ 10,123.82
2021	May	\$ 1,047.04	\$ 9,846.53		\$ 857.23	\$ 11,750.80
2021	June	\$ 375.81	\$ 9,530.50		\$ 339.15	\$ 10,245.46
2021	July	\$ 1,363.76	\$ 11,219.27		\$ 319.51	\$ 12,902.54
2021	August	\$ 577.59	\$ 13,814.82		\$ 348.73	\$ 14,741.14
2021	September	\$ 821.77	\$ 14,365.94		\$ 397.04	\$ 15,584.75
2021	October	\$ -	\$ 10,565.97	\$ 96.74	\$ 455.17	\$ 11,117.88

2021	November	\$ -	\$ 10,555.75	\$ 120.25	\$ 360.66	\$ 11,036.66
2021	December	\$ -	\$ 8,460.84	\$ 120.25	\$ 349.46	\$ 8,930.55
2021	TOTAL	\$ 36,864.53	\$ 121,126.11	\$ 337.24	\$ 5,277.14	\$ 163,605.02
2021	MO. AVERAGE	\$ 3,072.04	\$ 10,093.84	\$ 28.10	\$ 439.76	\$ 13,633.75
2020	January	\$ 833.43	\$ 9,987.27	-	\$ 312.00	\$ 11,132.70
2020	February	\$ 3,380.48	\$ 11,939.74	-	\$ 364.00	\$ 15,684.22
2020	March	\$ 1,396.63	\$ 7,154.90	-	\$ 263.25	\$ 8,814.78
2020	April	\$ 2,528.20	\$ 8,214.10	-	\$ 196.75	\$ 10,939.05
2020	May	\$ 1,347.43	\$ 8,715.86	\$ 144.82	\$ 358.75	\$ 10,566.86
2020	June	\$ 533.13	\$ 9,227.51		\$ 750.75	\$ 10,511.39
2020	July	\$ 623.73	\$ 9,929.69		\$ 1,279.50	\$ 11,832.92
2020	August	\$ 609.93	\$ 9,703.04		\$ 299.25	\$ 10,612.22
2020	September	\$ 800.97	\$ 11,125.87	\$ 366.82	\$ 2,018.00	\$ 14,311.66
2020	October	\$ 1,277.77	\$ 8,776.44	\$ 272.62	\$ 676.50	\$ 11,003.33
2020	November	\$ 2,353.90	\$ 8,231.88	\$ -	\$ 342.00	\$ 10,927.78
2020	December	\$ 3,029.59	\$ 7,311.78		\$ 298.75	\$ 10,640.12
2020	TOTAL	\$ 18,715.19	\$ 110,318.08	\$ 784.26	\$ 7,159.50	\$ 136,977.03
2020	MO. AVERAGE	\$ 1,559.60	\$ 9,193.17	\$ 65.36	\$ 596.63	\$ 11,414.75
2019	January	\$ 10,774.68	\$ 8,288.12	-	\$ 202.16	\$ 19,264.96
2019	February	\$ 7,100.55	\$ 11,406.80	-	\$ 229.41	\$ 18,736.76
2019	March	\$ 4,610.15	\$ 9,973.56	-	\$ 217.63	\$ 14,801.34
2019	April	\$ 2,594.06	\$ 10,000.04	-	\$ 276.88	\$ 12,870.98
2019	May	\$ 1,432.03	\$ 10,607.20		\$ 264.38	\$ 12,303.61
2019	June	\$ 1,008.73	\$ 13,276.41	-	\$ 487.88	\$ 14,773.02
2019	July	\$ 725.14	\$ 15,042.24	-	\$ 187.88	\$ 15,955.26
2019	August	\$ 499.79	\$ 17,751.05	\$ 588.16	\$ 651.49	\$ 19,490.49
2019	September	\$ 1,624.23	\$ 16,535.04	-	\$ 573.63	\$ 18,732.90
2019	October	\$ 2,157.59	\$ 9,469.36	\$ 244.17	\$ 771.38	\$ 12,642.50
2019	November	\$ 2,741.68	\$ 9,540.09	-	\$ 371.38	\$ 12,653.15
2019	December	\$ 2,487.36	\$ 9,348.48	-	\$ 300.25	\$ 12,136.09
2019	TOTAL	\$ 37,755.99	\$ 141,238.39	\$ 832.33	\$ 4,534.35	\$ 184,361.06
2019	MO. AVERAGE	\$ 3,146.33	\$ 11,769.87	\$ 69.36	\$ 377.86	\$ 15,363.42
2018	January	\$ 5,001.75	\$ 7,451.47	-	\$ 209.53	\$ 12,662.75
2018	February	\$ 5,370.79	\$ 9,590.51	-	\$ 234.36	\$ 15,195.66
2018	March	\$ 2,174.37	\$ 7,499.34	-	\$ 198.94	\$ 9,872.65
2018	April	\$ 2,295.44	\$ 9,351.20	-	\$ 211.94	\$ 11,858.58
2018	May	\$ 910.46	\$ 10,241.04	-	\$ 188.88	\$ 11,340.38
2018	June	\$ 838.26	\$ 11,506.40	-	\$ 177.21	\$ 12,521.87
2018	July	\$ 959.19	\$ 14,680.50	-	\$ 169.66	\$ 15,809.35
2018	August	\$ 1,121.25	\$ 12,842.28	-	\$ 192.89	\$ 14,156.42
2018	September	\$ 1,699.76	\$ 15,711.84	-	\$ 264.92	\$ 17,676.52
2018	October	\$ 2,462.96	\$ 11,956.49	-	\$ 252.53	\$ 14,671.98

2018	November	\$ 888.13	\$ 8,969.72	-	\$ 259.53	\$ 10,117.38
2018	December	\$ 1,175.19	\$ 12,706.84	-	\$ 295.63	\$ 14,177.66
2018	TOTAL	\$ 24,897.55	\$ 132,507.63	\$ -	\$ 2,656.02	\$ 160,061.20
2018	MO. AVERAGE	\$ 2,074.80	\$ 11,042.30	\$ -	\$ 221.34	\$ 13,338.43
2017	January	\$ 6,707.40	\$ 9,908.46	-	\$ 234.14	\$ 16,850.00
2017	February	\$ 4,525.93	\$ 9,904.53	-	\$ 210.03	\$ 14,640.49
2017	March	\$ 3,142.99	\$ 10,122.67	-	\$ 205.31	\$ 13,470.97
2017	April	\$ 2,862.31	\$ 9,368.46	-	\$ 187.55	\$ 12,418.32
2017	May	\$ 741.31	\$ 11,624.57	-	\$ 176.70	\$ 12,542.58
2017	June	\$ 1,074.51	\$ 12,465.85	-	\$ 150.28	\$ 13,690.64
2017	July	\$ 152.23	\$ 9,950.98	-	\$ 163.09	\$ 10,266.30
2017	August	\$ 926.17	\$ 12,045.47	-	\$ 1,150.91	\$ 14,122.55
2017	September	\$ 1,069.01	\$ 11,049.87	\$ 226.16	\$ 501.08	\$ 12,846.12
2017	October	\$ 2,383.57	\$ 9,223.39	\$ 241.35	\$ 254.46	\$ 12,102.77
2017	November	\$ 2,602.53	\$ 7,444.70	-	\$ 180.14	\$ 10,227.37
2017	December	\$ 5,358.58	\$ 8,154.48	-	\$ 208.91	\$ 13,721.97
2017	TOTAL	\$ 31,546.54	\$ 121,263.43	\$ 467.51	\$ 3,622.60	\$ 156,900.08
2017	MO. AVERAGE	\$ 2,628.88	\$ 10,105.29	\$ 38.96	\$ 301.88	\$ 13,075.01
2016	January	6,073.86	\$ 7,528.70	-	\$ 245.18	13,847.74
2016	February	\$ 4,361.92	\$ 8,602.24	-	\$ 245.47	\$ 13,209.63
2016	March	\$ 3,431.00	\$ 9,956.54	-	\$ 233.91	\$ 13,621.45
2016	April	\$ 2,331.52	\$ 9,622.98	-	\$ 236.03	\$ 12,190.53
2016	May	\$ 1,498.91	\$ 9,151.30	-	\$ 227.75	\$ 10,877.96
2016	June	\$ 685.93	\$ 9,404.68	-	\$ 242.82	\$ 10,333.43
2016	July	\$ 658.87	\$ 10,336.45	-	\$ 253.44	\$ 11,248.76
2016	August	\$ 666.06	\$ 10,443.93	-	\$ 264.21	\$ 11,374.20
2016	September	\$ 921.35	\$ 13,303.86	\$ 215.56	\$ 232.24	\$ 14,673.01
2016	October	\$ 1,310.31	\$ 9,519.88	\$ 217.31	\$ 283.21	\$ 11,330.71
2016	November	\$ 3,018.06	\$ 10,613.91	-	\$ 266.81	\$ 13,898.78
2016	December	\$ 5,439.36	\$ 8,307.79	-	\$ 227.35	\$ 13,974.50
2016	TOTAL	\$ 30,397.15	\$ 116,792.26	\$ 432.87	\$ 2,958.42	\$ 150,580.70
2016	MO. AVERAGE	\$ 2,533.10	\$ 9,732.69	\$ 36.07	\$ 246.54	\$ 12,548.39
2015	January	\$ 4,135.29	\$ 10,177.91	-	\$ 239.39	\$ 14,552.59
2015	February	\$ 6,966.63	\$ 11,012.81	-	\$ 218.49	\$ 18,197.93
2015	March	\$ 2,171.86	\$ 9,556.07	-	\$ 209.09	\$ 11,937.02
2015	April	\$ 2,951.75	\$ 7,819.32	-	\$ 201.56	\$ 10,972.63
2015	May	\$ 1,205.32	\$ 9,811.46	-	\$ 173.42	\$ 11,190.20
2015	June	\$ 927.16	\$ 10,977.15	-	\$ 198.88	\$ 12,103.19
2015	July	\$ 729.41	\$ 12,372.63	-	\$ 152.73	\$ 13,254.77
2015	August	\$ 884.59	\$ 13,283.00	-	\$ 180.79	\$ 14,348.38
2015	September	\$ 831.27	\$ 12,844.73	-	\$ 211.80	\$ 13,887.80
2015	October	\$ 1,630.50	\$ 10,259.76	-	\$ 221.96	\$ 12,112.22
2015	November	\$ 3,406.64	\$ 9,530.58	-	\$ 219.15	\$ 13,156.37

2015	December	\$ 4,303.30	\$ 9,659.95	-	\$ 196.79	\$ 14,160.04
2015	TOTAL	\$ 30,143.72	\$ 127,305.37	\$ -	\$ 2,424.05	\$ 159,873.14
2015	MO. AVERAGE	\$ 2,511.98	\$ 10,608.78	\$ -	\$ 202.00	\$ 13,322.76

Pender Public Schools

September 2023 General Fund Check Report

Check Number	Payee	Type	Amount
40447	AFLAC-12	September Payroll Liability	\$1,204.75
40448	AFLAC-10	September Payroll Liability	\$276.67
40449	Blue Cross Blue Shield of NE	September Payroll Liability	\$79,242.96
40450	Credit Management Services	September Payroll Liability	\$317.81
40451	Department of Revenue	September Payroll Liability	\$9,847.03
EFT	Employee Benefit Fund	September Payroll Liability	\$5,284.90
40452	Frontier Bank	September Payroll Liability	\$65,292.81
40453	Madison National Life Ins Co, Inc	September Payroll Liability	\$1,687.59
40454	Nebraska School Retirement	September Payroll Liability	\$53,624.93
40455	Pender General Fund	September Payroll Liability	\$650.00
40456	Pender/Thurston Education & Community Foundation	September Payroll Liability	\$779.56
40457	PPS Courtesy Fund	September Payroll Liability	\$1,382.50
40458	Special Building Fund	September Payroll Liability	\$1,053.14
40459	Vision Service Plan	September Payroll Liability	\$626.01
EFT	HSA Account Contributions	September Payroll Liability	\$5,295.27
40460	ABC Mobile Storage Inv	Storage Unit Rent	\$175.00
40461	Amazon Capital Services	Accounts Payable	\$1,335.82
40462	Appeara	Rug Rental	\$77.00
40463	Auto Glass Solutions	Van Windshield Repair	\$130.00
40464	Awards Unlimited Inc	Staff Recognition	\$217.92
40465	Ballinger, Kelly J	Cell Phone Stipend	\$375.00
40466	Canon Financial Services	Copier Lease	\$1,070.72
40467	Carpenter Paper Company	Custodial Supplies	\$2,729.47
40468	Crippen, Anthony S	Cell Phone Stipend	\$375.00
40469	Cubbys	Fuel & Misc Supplies	\$2,815.88
40470	Davis Design	Professional Fee	\$731.79
40471	Dolliver, Jason C	Cell Phone Stipend	\$375.00
40472	Dunn's Plumbing and Heating	Repairs	\$70.00
40473	Educational Service Unit #1	Accounts Payable	\$15,165.71
40474	Electronic Sound, Inc.	Phone System Repairs	\$432.50
40475	Electronic Systems, Inc.	Fire Alarm Inspection	\$198.80
40476	Essential Screens	Background Checks	\$409.50
40477	Fastwyre Broadband	Telephone	\$625.14
40478	First National Bank	Accounts Payable	\$3,753.13
40479	Franciscan Healthcare	CPR Supplies	\$588.00
40480	Frazseys	Meeting Supplies	\$43.96
40481	Grainger	Maintenance Supplies	\$618.33
40482	Harrison, Daryl G	Cell Phone Stipend	\$300.00
40483	Hegge Screen Printing, LLC	PRIDE & Staff Shirts	\$2,797.25
40484	Hoffman, Luke J	Cell Phone Stipend	\$375.00
40485	IXL Learning	Annual License Renewal	\$1,263.00
40486	Janke Auto Co.	Van Maintenance	\$462.54
40487	John Deere Financial	Cordless Blower System	\$714.99
40488	Johnson Hardware Co., LLC	Keys	\$58.55
40512	Katie Lierman	Reimbursement	\$495.00
40489	Kayla Welch, BCBA	BCBA Services	\$750.00
40490	KSB School Law	Professional Fee	\$375.00
40491	Lamp Auto Parts	DEF Fluid	\$130.02
40492	Lexia Learning Systems LLC	LETRS Training Bundle	\$399.00
40493	Lorensen Lumber & Grain	Maintenance Supplies	\$931.66
40494	Matheson Tri-Gas, Inc.	Welding Gas & Bottle Rent	\$287.92
40495	Meyer, Gregory P	Cell Phone Stipend	\$300.00
40496	NASB	Registration Fees	\$663.00
40497	Newton Diesel	Bus Maintenance	\$2,067.65
40498	Norfolk Daily News	Public Notice	\$90.50
40499	Pearson Education, Inc.	Classroom Supplies	\$21.54
40500	Pender Ace Hardware	Maintenance & Custodial	\$606.88
40501	Pender Municipal Utilities	August Utilities	\$17,026.61

40502	Pender School Nutrition Fund	Reimbursement	\$1,690.35
40503	Petty Cash Fund	Reimbursement	\$1,510.01
40504	Rays Midbell	Wireless Microphone	\$65.00
40505	Scholastic Inc	Classroom Supplies	\$19.77
40506	Sturek Media, Inc.	Printing	\$2,713.22
40507	Swinton, Daniel L	Cell Phone Stipend	\$375.00
40508	Sysco Lincoln	Food & Supplies	\$53.88
40509	TM Painting & Handyman	618 Maple House Painting	\$3,600.00
40510	UNL Haskell Ag Lab	Career Day Registration Fee	\$156.00
40511	Verizon Wireless	wifi	\$80.02
		General Fund AP & PR Liab Total	\$299,258.96
		General Fund Payroll Total	\$212,622.65
		School Nutrition Fund Total	\$43,779.43
		Activity Fund Total	\$33,322.65
		Employee Benefit Fund Total	\$8,127.04

Pender Public Schools

September 2023 School Nutrition Fund Check Report

Check Number	Payee	Type	Amount
8700	Blue Cross Blue Shield of NE	September Payroll	\$3,415.54
8701	Credit Management Services, Inc.	September Payroll	\$184.83
8702	Department of Revenue	September Payroll	\$171.10
EFT	Employee Benefit Fund	September Payroll	\$71.13
8703	Frontier Bank	September Payroll	\$1,573.54
8704	Madison National Life Ins Co, Inc	September Payroll	\$64.93
8705	Nebraska School Retirement	September Payroll	\$1,669.27
8706	Pender/Thurston Education & Community Foundation	September Payroll	\$10.44
8707	PPS Courtesy Fund	September Payroll	\$75.00
8708	Special Building Fund	September Payroll	\$0.53
8709	Vision Service Plan	September Payroll	\$68.25
EFT	HSA Account	September Payroll	\$263.27
8710	AT&T Mobility	September Payroll	\$29.00
8711	Cash-Wa Distributing Co	Food & Supplies	\$10,504.70
8712	Clinch Produce	Produce	\$372.00
8713	Cole Papers	Dish Machine Chemicals	\$729.21
8714	Cubbys	SFSP Fuel & Misc Supplies	\$288.52
8715	Hiland Dairy Foods Company, LLC	Milk and Juice	\$1,882.83
8716	Meyer, Lorie J	Refund	\$51.00
8717	Sysco Lincoln	Food & Supplies	\$15,766.59
		SNF AP & PR Liab Total	\$37,191.68
		SNF Payroll Total	\$6,585.90
		SNF TOTAL	\$43,777.58

**PENDER PUBLIC SCHOOL
EXPENDITURE BUDGET REPORT
August 30, 2023**

		Annual Budget	YTD	Budget Balance	Percent Expended	Percent Remaining
01100	Regular Education	3,329,993.00	3,239,864.11	90,128.89	97.29%	2.71%
01200	School Age Special Education	924,823.00	919,016.77	5,806.23	99.37%	0.63%
01300	Summer School/Driver's Ed	6,763.00	6,222.10	540.90	92.00%	8.00%
02120/30	School Counselor/Nurse	113,954.00	112,383.54	1,570.46	98.62%	1.38%
02141-02190	ESU #1 SPED Services	198,121.00	148,323.82	49,797.18	74.87%	25.13%
02200	Staff Inservice/Library	152,047.00	128,692.58	23,354.42	84.64%	15.36%
02310	Board of Education	148,235.00	165,738.05	(17,503.05)	111.81%	-11.81%
02320	Superintendent	199,375.00	195,104.46	4,270.54	97.86%	2.14%
02330	Legal Services	10,000.00	405.00	9,595.00	4.05%	95.95%
02400	Principals/Student Support	378,652.00	365,567.33	13,084.67	96.54%	3.46%
02500	Technology/Administrative	284,216.00	198,152.14	86,063.86	69.72%	30.28%
02600	Custodial/Maintenance/Equipment/Safety	792,086.00	741,173.08	50,912.92	93.57%	6.43%
02700	Regular & SPED Transportation	341,869.00	288,002.37	53,866.63	84.24%	15.76%
03400	Monsanto/College Access Grants	17,500.00	298.85	17,201.15	1.71%	98.29%
03535	High Ability Learner Grant	4,784.00	3,521.83	1,262.17	73.62%	26.38%
06200	Title I	83,662.00	84,162.72	(500.72)	100.60%	-0.60%
06310	Title II, Part A (NCLB Consolidated)	9,882.00	9,965.19	(83.19)	100.84%	-0.84%
06402	IDEA Part B (611) Transportation	400.00	-	400.00	0.00%	100.00%
06408	IDEA Part B (611) Base Allocation, Birth-Age 21	11,430.00	-	11,430.00	0.00%	100.00%
06410	IDEA Enrollment/Poverty (611)	90,230.00	69,118.50	21,111.50	76.60%	23.40%
06925	Title III LEP Grant	1,561.00	-	1,561.00	0.00%	100.00%
06992	USDE REAP Grant	33,218.00	33,090.47	127.53	99.62%	0.38%
06997	ESSER II Disbursements	206,644.00	73,257.71	133,386.29	35.45%	64.55%
06998	ESSER III Disbursements	464,416.00	8,407.50	456,008.50	1.81%	98.19%
08000	Transfer to Hot Lunch Fund/Activity	15,000.00	-	15,000.00	0.00%	100.00%
TOTAL		7,818,861.00	6,790,468.12	1,028,392.88	86.85%	13.15%

Annual Budget Expenditure History

2021-22	Budget Totals	\$7,508,470.00	\$6,263,452.58	\$1,245,017.42	83.42%	16.58%
2020-21	Budget Totals	\$6,538,920.00	\$5,899,938.08	\$638,981.92	90.23%	9.77%
2019-20	Budget Totals	\$6,362,013.00	\$5,342,082.03	\$1,019,930.97	83.97%	16.03%
2018-19	Budget Totals	\$6,210,244.00	\$5,662,504.01	\$547,739.99	91.18%	8.82%
2017-18	Budget Totals	\$6,048,238.00	\$5,378,923.13	\$669,314.87	88.93%	11.07%
2016-17	Budget Totals	\$5,913,769.00	\$5,166,861.84	\$746,907.16	87.37%	12.63%
2015-16	Budget Totals	\$5,588,969.00	\$5,034,277.10	\$554,691.90	90.08%	9.92%
2014-15	Budget Totals	\$5,512,171.00	\$5,169,685.27	\$342,485.73	93.79%	6.21%
2013-14	Budget Totals	\$5,363,779.00	\$4,495,599.46	\$868,179.54	83.81%	16.19%
2012-13	Budget Totals	\$5,181,324.00	\$4,299,804.82	\$881,519.18	82.99%	17.01%
2011-12	Budget Totals	\$5,157,330.00	\$4,326,767.92	\$830,562.08	83.90%	16.10%
2010-11	Budget Totals	\$4,608,280.00	\$3,795,098.53	\$813,181.47	82.35%	17.65%
2009-10	Budget Totals	\$4,455,210.00	\$3,674,026.34	\$781,183.66	82.47%	17.53%
2008-09	Budget Totals	\$3,849,028.00	\$3,246,620.10	\$602,407.90	84.35%	15.65%
2007-08	Budget Totals	\$3,692,279.00	\$3,247,688.62	\$444,590.38	87.96%	12.04%
2006-07	Budget Totals	\$3,677,846.00	\$3,238,808.50	\$439,037.50	88.06%	11.94%
2005-06	Budget Totals	\$3,526,423.00	\$3,218,365.64	\$308,057.36	91.26%	8.74%
2004-05	Budget Totals	\$3,560,021.00	\$2,932,584.04	\$627,436.96	82.38%	17.62%
2003-04	Budget Totals	\$3,142,855.00	\$2,778,649.30	\$364,205.70	88.41%	11.59%

Pender Public Schools

Vendor Detail Report: Amazon

Vendor	PO #	Type	Amount
Amazon Capital Services		flip chart easel pads	\$78.39
Amazon Capital Services		markers for classrooms	\$185.97
Amazon Capital Services		sketchbooks for arty	\$55.52
Amazon Capital Services		classroom supplies	\$62.54
Amazon Capital Services		classroom supplies	\$20.94
Amazon Capital Services		markers for Bessmer	\$61.99
Amazon Capital Services		markers for classrooms	\$185.97
Amazon Capital Services		recess volleyballs	\$119.94
Amazon Capital Services		cord protector wire loom, nano station w/dedicated wi-fi management	\$148.93
Amazon Capital Services		dremel filament, microfiber cleaning clothes	\$40.98
Amazon Capital Services		vacuum and gum remover	\$312.08
Amazon Capital Services		light keys	\$35.98
Amazon Capital Services	22/23--305	Laminating sheets	\$26.59
			\$1,335.82

Pender Public Schools

Vendor Detail Report: First National Bank

Vendor	PO #	Type	Amount
First National Bank		Longman Reader books for ELA	\$39.98
First National Bank		Introductory Guitar books	\$166.50
First National Bank		apple tv fee	\$8.47
First National Bank		classroom resources	\$63.51
First National Bank		YouTube renewal for Kolbeck	\$149.79
First National Bank		renewal of whiteboard.fi, xtramath.org and edpuzzle pro	\$280.17
First National Bank		homecoming supplies for elementary	\$297.52
First National Bank		Personal Finance electronic textbook renewal	\$639.68
First National Bank		Generation Genius renewal	\$495.00
First National Bank		classroom supplies	\$54.95
First National Bank		office supplies	\$39.26
First National Bank		pendragon logo for conference room	\$97.34
First National Bank		monthly time clock fee	\$67.95
First National Bank		supplies for classified staff lunch	\$117.63
First National Bank		supplies	\$41.49
First National Bank		brackets and shelves for office	\$48.05
First National Bank		office supplies	\$112.49
First National Bank		driving record checks	\$330.00
First National Bank	22/23--179	4 pieces music for choir	\$107.98
First National Bank	22/23--222	Pill Bugs/Sow Bugs pack of 50	\$120.85
First National Bank	22/23--299	Finale software for music arrangements. Single computer software license.	\$84.54
First National Bank	22/23--309	\$129.00 for American School Counselor Association and \$35.00 for Nebraska School Counselor Association dues	\$164.00
First National Bank	22/23--302	Secret Stories for Elementary	\$179.27
First National Bank	22/23--310	Transformer for Electronic Door System	\$46.71
Sub Total			\$3,753.13

NOTICE OF BUDGET HEARING AND BUDGET SUMMARY

Pender Public Schools (87-0001) in Thurston County, Nebraska

PUBLIC NOTICE is hereby given, in compliance with the provisions of State Statute Sections 13-501 to 13-513, that the governing body will meet on the 18th day of September, 2023 at 8:00 o'clock, P.M., at Pender Public Schools in Room #101 for the purpose of hearing support, opposition, criticism, suggestions or observations of taxpayers relating to the following proposed budget and to consider amendments relative thereto. The budget detail is available at the office of the Clerk/Secretary during regular business hours. For more information on statewide receipts and expenditures, and to compare cost per pupil and performance to other school districts, go to: <https://nep.education.ne.gov>

FUNDS	Actual Disbursements & Transfers	Actual/Estimated Disbursements & Transfers	Budgeted Disbursements & Transfers	Necessary Cash Reserve (4)	Total Available Resources Before Property Taxes (5)	Total Personal and Real Property Tax Requirement (7)
	2021-2022 (1)	2022-2023 (2)	2023-2024 (3)			
General	\$ 6,259,835.00	\$ 6,787,664.00	\$ 8,237,985.00	\$ 1,975,000.00	\$ 5,305,689.00	\$ 4,956,865.00
Depreciation	\$ 203,369.00	\$ 158,549.00	\$ 286,857.00		\$ 286,857.00	
Employee Benefit	\$ 38,608.00	\$ 56,661.00	\$ 251,093.00	\$ -	\$ 251,093.00	
Contingency	\$ -	\$ -	\$ -		\$ -	
Activities	\$ 284,553.00	\$ 383,225.00	\$ 435,000.00	\$ 25,000.00	\$ 460,000.00	
School Nutrition	\$ 339,294.00	\$ 428,816.00	\$ 499,669.00	\$ 117,104.00	\$ 616,773.00	
Bond	\$ -	\$ -	\$ 50,190.00	\$ -	\$ 50,190.00	\$ -
Special Building	\$ 1,010,315.00	\$ 759,450.00	\$ 2,500,000.00		\$ 1,965,000.00	\$ 540,404.00
Qualified Capital Purpose Undertaking	\$ 10,279.00	\$ -	\$ 45,606.00	\$ -	\$ 45,606.00	\$ -
Cooperative	\$ -	\$ -	\$ -	\$ -	\$ -	
Student Fee	\$ 4,500.00	\$ -	\$ 68.00	\$ -	\$ 68.00	
	\$ -	\$ -	\$ -	\$ -	\$ -	
TOTALS	\$ 8,150,753.00	\$ 8,574,365.00	\$ 12,306,468.00	\$ 2,117,104.00	\$ 8,981,276.00	\$ 5,497,269.00

	Bond Purposes	Non-Bond Purposes	Total
Breakdown of Property Tax	\$ -	\$ 5,497,269.00	\$ 5,497,269.00

Notice of Special Hearing To Set Final Tax Request

Pender Public Schools (87-0001) in Thurston County, Nebraska

PUBLIC NOTICE is hereby given, in compliance with the provisions of State Statute Section 77-1632, that the governing body will meet on the 18th day of, September 2023 at 8:05 o'clock P.M., at Pender Public Schools in Room #101 for the purpose of hearing support, opposition, criticism, suggestions or observations of taxpayers relating to setting the final tax request.

	2022-2023	2023-2024	Change
Property Valuations	617,788,530	666,079,250	8%

2022-2023 Budget Information

2023-2024 Budget Information

Fund	2022-2023 Operating Budget	2022-2023 Property Tax Request	2022 Tax Rate	Property Tax Rate (2022-2023 Request Divided By 2023 Valuation)	2023-2024 Operating Budget	2023-2024 Proposed Property Tax Request	Proposed 2023 Tax Rate	Change in Tax Rate	Change in Operating Budget
General Fund	7,818,861.00	5,068,438.00	0.820416	0.760936	8,237,985.00	4,956,865.00	0.744185	-9%	5%
Bond Fund(s) K - 12			0.000000	0.000000	50,190.00	-	0.000000	#DIV/0!	0
Bond Fund(s) K - 8			0.000000	0.000000			0.000000	#DIV/0!	0
Bond Fund(s) 9 - 12			0.000000	0.000000			0.000000	#DIV/0!	0
Bond Fund			0.000000	0.000000			0.000000	#DIV/0!	0
Special Building Fund	4,000,000.00	222,222.00	0.035971	0.033363	2,500,000.00	540,404.00	0.081132	126%	-38%
Qualified Capital Purpose Undertaking Fund K - 12			0.000000	0.000000	45,606.00	-	0.000000	#DIV/0!	0
Qualified Capital Purpose Undertaking Fund K - 8			0.000000	0.000000			0.000000	#DIV/0!	0
Qualified Capital Purpose Undertaking Fund 9 - 12			0.000000	0.000000			0.000000	#DIV/0!	0
Total	11,818,861.00	5,290,660.00	0.856387	0.794299	10,833,781.00	5,497,269.00	0.825317	-4%	-8%

RESOLUTION SETTING THE PROPERTY TAX REQUEST

RESOLUTION NO. 9.18.23

WHEREAS, Nebraska Revised Statute 77-1632 and 77-1633 provides that the Governing Body of Pender Public Schools passes by a majority vote a resolution or ordinance setting the tax request; and

WHEREAS, a special public hearing was held as required by law to hear and consider comments concerning the property tax request;

NOW, THEREFORE, the Governing Body of Pender Public Schools resolves that:

- 1. The 2023-2024 property tax request be set at:

General Fund:	\$	4,956,865.00
Bond Fund:	\$	-
Special Building Fund:	\$	540,404.00
Qualified Capital Purpose	\$	-
Undertaking Fund:		

- 2. The total assessed value of property differs from last year’s total assessed value by 7.82 percent.
- 3. The tax rate which would levy the same amount of property taxes as last year, when multiplied by the new total assessed value of property would be 0.794299 per \$100 of assessed value.
- 4. Pender Public Schools proposes to adopt a property tax request that will cause its tax rate to be 0.825317 per \$100 of assessed value.
- 5. Based on the proposed property tax request and changes in other revenue, the total operating budget of Pender Public Schools will increase (or decrease) last year’s budget by -8.33 percent.
- 6. A copy of this resolution be certified and forwarded to the County Clerk on or before October 15, 2023.

Motion by _____, seconded by _____ to adopt Resolution #9.18.23.

Voting yes were:

Voting no were:

Dated this 18th day of September, 2023

**Pender Public Schools
10 Year Budget Overview**

General Information

Year	Actual Value	% Increase	Actual Difference	Actual Value	% Increase	Actual Difference
District Valuation			GF Budget of Expenditures			
2014	\$ 530,091,061.00	30.42%	\$ 123,645,291.00	\$ 5,512,171.00	2.77%	\$ 148,392.00
2015	\$ 606,225,653.00	14.36%	\$ 76,134,592.00	\$ 5,588,969.00	1.39%	\$ 76,798.00
2016	\$ 618,356,152.00	2.00%	\$ 12,130,499.00	\$ 5,913,769.00	5.81%	\$ 324,800.00
2017	\$ 617,362,627.00	-0.16%	\$ (993,525.00)	\$ 6,048,238.00	2.27%	\$ 134,469.00
2018	\$ 607,500,485.00	-1.60%	\$ (9,862,142.00)	\$ 6,210,244.00	2.68%	\$ 162,006.00
2019	\$ 605,473,605.00	-0.33%	\$ (2,026,880.00)	\$ 6,362,013.00	2.44%	\$ 151,769.00
2020	\$ 590,170,481.00	-2.53%	\$ (15,303,124.00)	\$ 6,538,920.00	2.78%	\$ 176,907.00
2021*	\$ 596,360,895.00	1.05%	\$ 6,190,414.00	\$ 7,508,471.00	14.83%	\$ 969,551.00
2022*	\$ 617,788,530.00	3.59%	\$ 21,427,635.00	\$ 7,818,861.00	4.13%	\$ 310,390.00
2023*	\$ 666,079,250.00	7.82%	\$ 48,290,720.00	\$ 8,237,985.00	5.36%	\$ 419,124.00

General Fund Tax Request

Year	Actual Value	% Increase	Actual Difference	Actual Value	% Increase	Actual Difference
Levy			Tax Request			
2014	0.6980	-26.53%	\$ (0.2520)	\$ 3,700,000.00	-4.18%	\$ (161,236.31)
2015	0.6106	-12.52%	\$ (0.0874)	\$ 3,701,630.27	0.04%	\$ 1,630.27
2016	0.6410	4.98%	\$ 0.0304	\$ 3,963,433.29	7.07%	\$ 261,803.02
2017	0.6707	4.63%	\$ 0.0297	\$ 4,140,586.83	4.47%	\$ 177,153.54
2018	0.6961	3.79%	\$ 0.0254	\$ 4,228,682.79	2.13%	\$ 88,095.96
2019	0.7108	2.12%	\$ 0.0147	\$ 4,303,877.00	1.78%	\$ 75,194.21
2020 **	0.8258	16.18%	\$ 0.1150	\$ 4,873,777.00	13.24%	\$ 569,900.00
2021	0.8282	0.28%	\$ 0.0023	\$ 4,938,795.00	1.33%	\$ 65,018.00
2022	0.8204	-0.93%	\$ (0.0077)	\$ 5,068,438.00	2.62%	\$ 129,643.00
2023	0.7442	-9.29%	\$ (0.0762)	\$ 4,956,865.00	-2.20%	\$ (111,573.00)

Special Building Fund Tax Request

Year	Actual Value	% Increase	Actual Difference	Actual Value	% Increase	Actual Difference
Levy			Tax Request			
2014	0.0755	54.08%	\$ 0.0265	\$ 400,000.00	50.20%	\$ 200,813.13
2015	0.0743	-1.59%	\$ (0.0012)	\$ 490,151.51	18.39%	\$ 90,151.51
2016	0.0666	-10.41%	\$ (0.0077)	\$ 411,603.03	-19.08%	\$ (78,548.48)
2017	0.0491	-26.26%	\$ (0.0175)	\$ 303,030.30	-35.83%	\$ (108,572.73)
2018	0.0416	-15.31%	\$ (0.0075)	\$ 252,525.25	-20.00%	\$ (50,505.05)
2019	0.0559	34.45%	\$ 0.0143	\$ 338,384.00	25.37%	\$ 85,858.75
2020	0.0169	-69.68%	\$ (0.0389)	\$ 100,000.00	-238.38%	\$ (238,384.00)
2021	0.0381	124.91%	\$ 0.0212	\$ 227,273.00	56.00%	\$ 127,273.00
2022	0.0360	-5.61%	\$ (0.0021)	\$ 222,222.00	-2.27%	\$ (5,051.00)
2023	0.0811	125.55%	\$ 0.0452	\$ 540,404.00	58.88%	\$ 318,182.00

System-Wide Tax Request

Year	Actual Value	% Increase	Actual Difference	Actual Value	% Increase	Actual Difference
Levy			Tax Request			
2014	0.8879	-22.73%	\$ (0.2612)	\$ 4,636,481.82	0.72%	\$ 33,169.75
2015	0.7843	-11.67%	\$ (0.1036)	\$ 4,686,021.18	1.07%	\$ 49,539.36
2016	0.8101	3.29%	\$ 0.0258	\$ 4,941,591.87	5.45%	\$ 255,570.69
2017	0.8162	0.75%	\$ 0.0061	\$ 4,971,101.98	0.60%	\$ 29,510.11
2018	0.8038	-1.52%	\$ (0.0124)	\$ 4,814,541.37	-3.15%	\$ (156,560.61)
2019	0.8064	0.33%	\$ 0.0026	\$ 4,842,564.00	0.58%	\$ 28,022.63
2020	0.8428	4.51%	\$ 0.0364	\$ 4,973,777.00	2.71%	\$ 131,213.00
2021	0.8663	2.79%	\$ 0.0235	\$ 5,166,068.00	3.87%	\$ 192,291.00
2022	0.8564	-1.14%	\$ (0.0099)	\$ 5,290,660.00	2.41%	\$ 124,592.00
2023	0.8253	-3.63%	\$ (0.0311)	\$ 5,497,269.00	3.91%	\$ 206,609.00

* Includes ESSER II & III, which inflates this number by \$671,060

** Increased NCR from \$600,000 to \$1,150,000



SEPTEMBER SECONDARY PRINCIPAL'S REPORT

PENDER PUBLIC SCHOOLS - 9/18/23

MISSION STATEMENT

The mission of the Pender Public School District is to provide quality educational opportunities in a safe, positive learning environment that motivates and challenges all students to become productive and responsible citizens.



PERSONAL GOALS

BE EPIC - Make Your Story Worth Telling

- 1) I will be visible in the hallways and classrooms on a regular basis.
- 2) I will expand on the positive school culture by building relationships with staff & students through effective communication.
- 3) I will be firm, fair, and consistent with students.

LB 399

- Dr. Martin Luther King, Jr.'s birthday (January 15, 1929)
- Abraham Lincoln's birthday (February 12, 1809)
- George Washington's birthday (February 22, 1732)
- Memorial Day (May - the last Monday in May)
- Constitution Day (September 17 - every year)
- Veterans Day (November 11 - every year)
- Thanksgiving Day (November - 4th Thursday in November)
- Native American Heritage Day (November - the Friday after Thanksgiving)

SEPTEMBER 17TH - CONSTITUTION DAY

MRS. CONNER

MR. VOLK

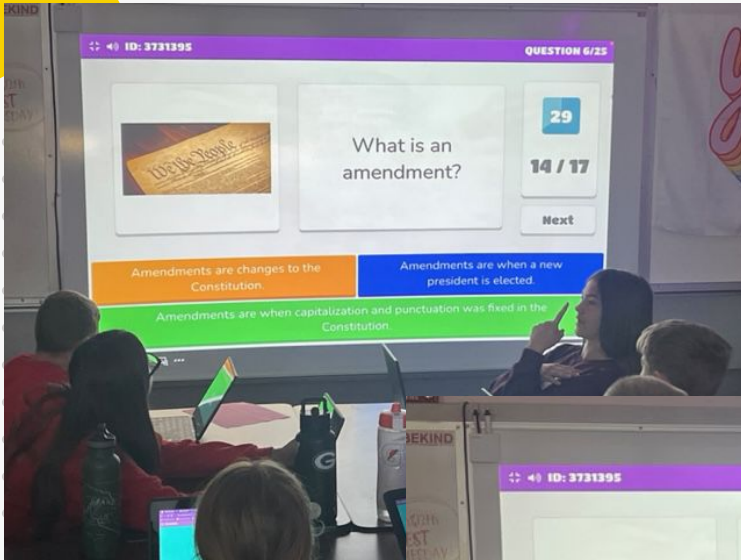

- Kahoot over the parts of the Constitution
- Booklet with Trivia



- Videos from Prager U
- Creation & Implementation of the US Constitution
- Worksheet for Understanding

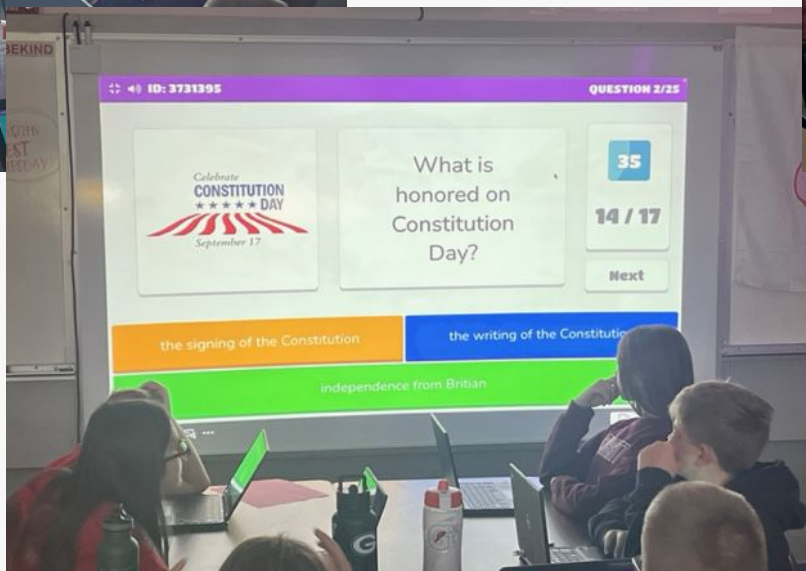

NAME: _____
DATE: _____

CONSTITUTION DAY

- 1) What is the main topic of this video?
- 2) What were two things you learned from this video?
- 3) What is the main topic of this video?
- 4) What were two things you learned from this video?
- 5) What is the main topic of this video?
- 6) What were two things you learned from this video?

WORKSHOPS/CONFERENCES/MEETINGS

PAST

- ESU1 Principal's Meeting
- Leadership Cadre - In House
- EDU 710 - School Improvement Planning
- New Teacher Rounds
- NSCAS/MAPS Testing

UPCOMING

- ESU1 Principal's Zoom Meeting
- Leadership Cadre - ESU1
-

HOMECOMING 2023 - STARRY NIGHT



HOMECOMING 2023 - STARRY NIGHT



A HUGE THANK YOU to the Student Council students along with Mr. King and Miss Jetensky for their hard work.



LifeServe Blood Drive



- September 12th
- NHS Sponsored
- 11 from Pender Schools Donated Blood

ONE ACT - PLAY PRODUCTION

Addie Hejl



- WSC Students
- Great Interviews
- Tryouts Held
- 14 Cast Members
- Plenty of Crew

Claire Jensen



eSports

Coach Jennifer Davis

- 14 Fall Members
- 11 Boys – 3 Girls
- New Competition Room
- Fall Season – 9/18 to 10/27
- State – November 17th
- Varsity Valorant Team
- Varsity Super Smash Bros
- JV Smash Bros (2)

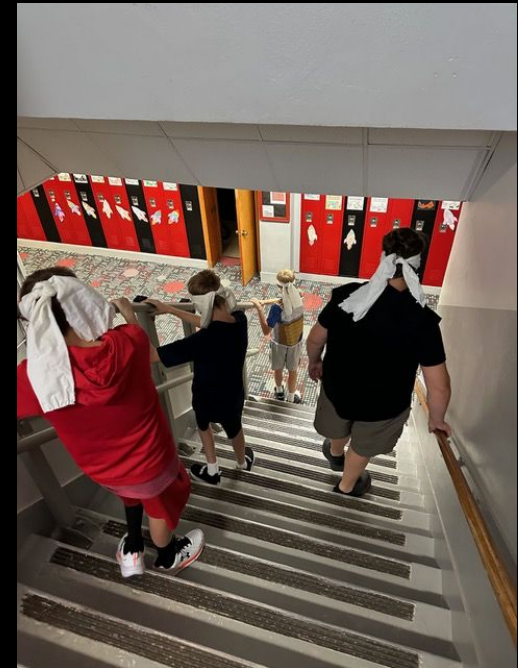

FFA

- 82 Members
- First Competition
Tomorrow- Range Judging
- Sept. 26th - District Dairy
Judging
- Sept. 27th - Farm Safety Day

Sponsor - Allison Claussen
Assistant - Kensie Hanson

2024 National Merit Scholarship Program Semifinalist

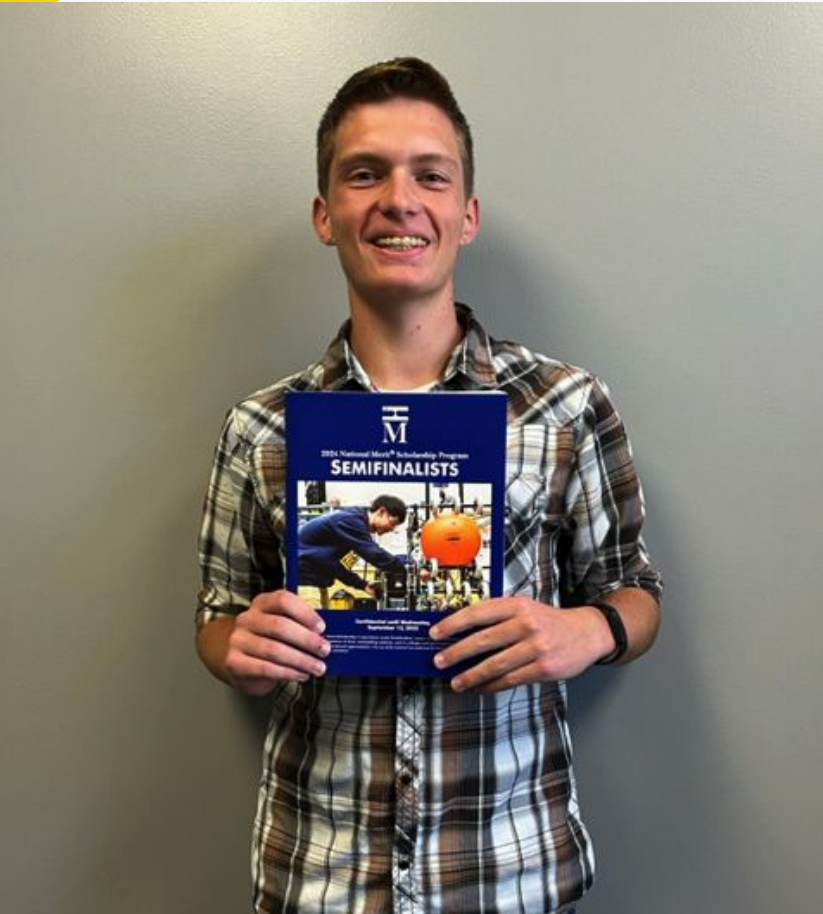

CALEB KELLY

- Annual Academic Competition
- 111 Nebraska Students are Semifinalists
- 1.3 Million Students Took Pre-SAT Test
- 16,000 Semifinalists Nationwide

Football Classifications

Looking Ahead: The Cut Off Number is 47 for 8 Man Football

2024-2025 Cycle: 11th-17, 10th-18, 9th-22 = 57 TOTAL (Grace Period)

2026-2027 Cycle: 9th-22, 8th-13, 7th-15 = 50 TOTAL

2028-2029 Cycle: 7th-15, 6th-15, 5th-16 = 46 TOTAL

DUAL CREDIT CLASSES

Students =	27
1st Semester Students	27
2nd Semester Students	0
Total Dual Credit Classes 2023-2024	64
1st Semester Classes #	64
2nd Semester Classes #	0
Total Dual Credit Hours 2023-2024	187.5
1st Semester Credit Hour total	187.5
2nd Semester Credit Hour total	0

P2T - 32.5 hours

In House - 89 hours

Online - 66 hours

Mr. Nixon's Notes

9/11 - UNL Admissions Rep

9/11 - College Access Work Night

9/13 - ASVAB Test 11th Grade

9/21 - Educational Planning Program - Seniors to NECC

9/29 - Apply to College Day

10/9 - College Access Work Night

UPCOMING EVENTS

Sept. 19 - It's a **BIG DAY!**

Sept. 23 - EHC Softball

Sept. 23 - EHC Girl's Golf

Sept. 27 - Farm Safety Day

Oct. 2 - District Girls Golf & Sub District Softball

Oct. 5 - EHC Cross Country in Pender

Oct. 6-7 Softball District Finals

Oct. 12 - Cross Country Districts in Pender / EHC Volleyball

THANK YOU!



Pender Public Schools

**Superintendent's Report
September 18, 2023**

It's a Great Day to be a Pendragon!

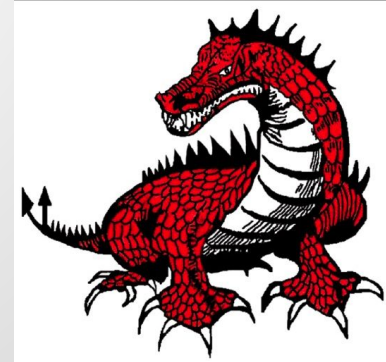
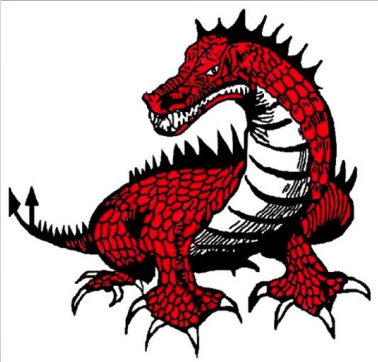



The mission of the Pender Public School District is to provide quality educational opportunities in a safe, positive learning environment that motivates and challenges all students to become productive and responsible citizens

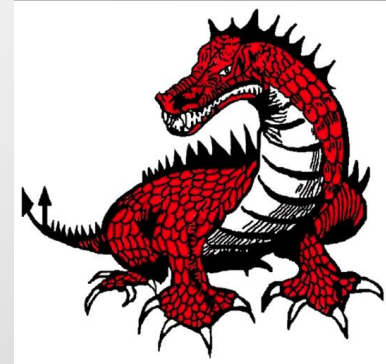
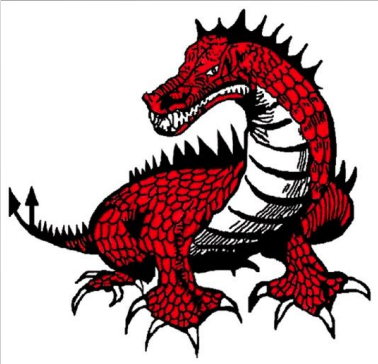

Superintendent Goals (23-24)

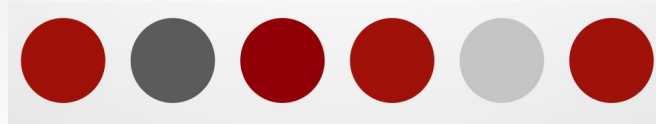

- Facilitate the development of an efficient and effective Administrative Team
 - PPS has a new Administrative Team for the first time since the start of the 2013-2014 school year
- Visit every classroom at least 1 time per month
- Engage P-12 staff in development opportunities rather than keep P-6 and 7-12 separate
- Difficult conversations and situations:
 - Tackle them head on
 - Avoid none of them
- Conduct a physical walkthrough of the facility monthly
- Learn as much as possible about LB 243 so the District can be best guided financially in 23-24 and in the years to come
- Effectively balance all of my roles and exceed expectations for each of them
 - Superintendent, Coach, Husband, Dad, etc.

Administrative Team Goals (23-24)

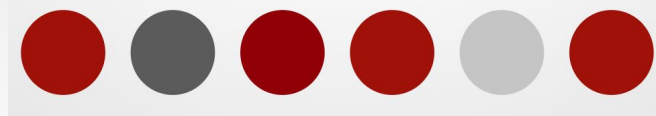

- Effectively utilize staff committees
- Communicate with and engage Classified Staff more effectively by:
 - Meeting with department leaders weekly (Tony, Pam, Dan)
 - Including Deanna in Administrative Team Meetings
- Something teacher centered
- Something student centered

Conferences, Workshops, Meetings, Etc.

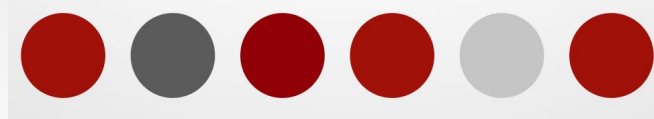

- Aug 23 - ESU 1 Superintendent's Meeting
- Aug 23 - Play Production Coach Interview
- Aug 24 - Play Production Coach Interview
- Aug 30 - Special Board Meeting
- Aug 30 - KTIC Radio Interview
- Sept 4 - No School - Labor Day
- Sept 4 - LB 844 Hearing Deadline
- Sept 6 - NASB Area Membership Meeting
- Sept 7 - Building Addition Walkthrough
- Sept 11 - PED / PCD Meeting
- Sept 14 - 914 Roofing (New Gym)
- Sept 14 - Joint Public Hearing
- Sept 18 - P2T Board Meeting
- Sept 18 - Board of Education Meeting
- Sept 19 - Voss Lighting (PPS Building)
- Sept 22 - NE NE Superintendent's
- Sept 28 - Flu Shots at PPS
- Oct 3 - Musco Lighting (PSC)
- Oct 16 - Board of Education Meeting
- Nov 3-7 - Out of the Office

School Improvement

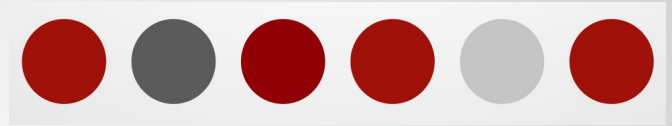

- Aug 23
 - Elem - Work Time
 - Sec - Room Time
- Aug 30
 - Elem - Book Study
 - Sec - Book Study
- Sept 6
 - Elem - MTSS
 - Sec - Staff Meeting
- Sept 13
 - Elem - MAP & IXL Reports
 - Sec - MAP & IXL Reports
 - Non assessment teachers - professional growth policy
- Sept 20
 - Elem - LETRS
 - Sec - SS Curriculum Update
- Sept 27
 - Elem - LETRS
 - Sec - Work & Life Balance
- Oct 4
 - Elem - LETRS / Kami Training
 - Sec - Kami Training
- Oct 11
 - Elem - LETRS
 - Sec - Room Time

Cell Phone Reception

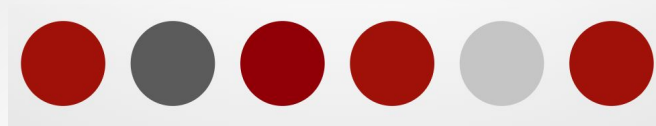

- Poor cell phone reception in our area is creates an unsafe environment
- This is a problem in various places throughout Pender and the surrounding area
- It is a significant problem in many portions of the building
- I have been in communication with Verizon representatives
- Hopefully the issue is able to be resolved very, very soon

Phone System

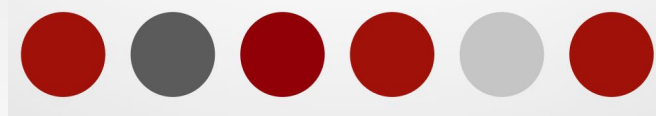

- We are having significant issues with our phone system
- All parties involved think the issue is due to someone else's responsibility
- Tony is working to reconcile the issue
- A complete overhaul of the system MAY be required

Fire Suppression System

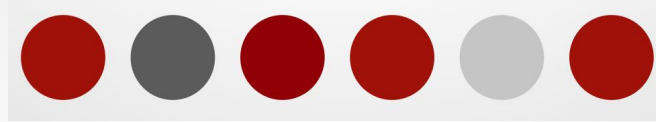

- Every 5 years, an in depth inspection of our fire suppression system is required
- Ahern services and inspects our fire suppression system on a routine basis and has done so for a lot of years
- The cost to complete the needed inspection is \$4,726
- Ahern will be here soon to complete this work

New Coaches

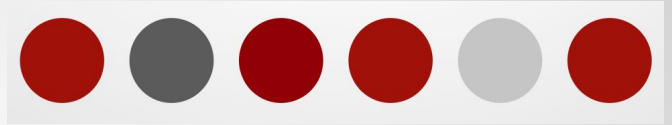

- Play Production
 - Claire Jensen (WSC Student)
 - Addie Hejl (WSC Student)
- Boys Basketball
 - Andy Welsh
- Welcome!!

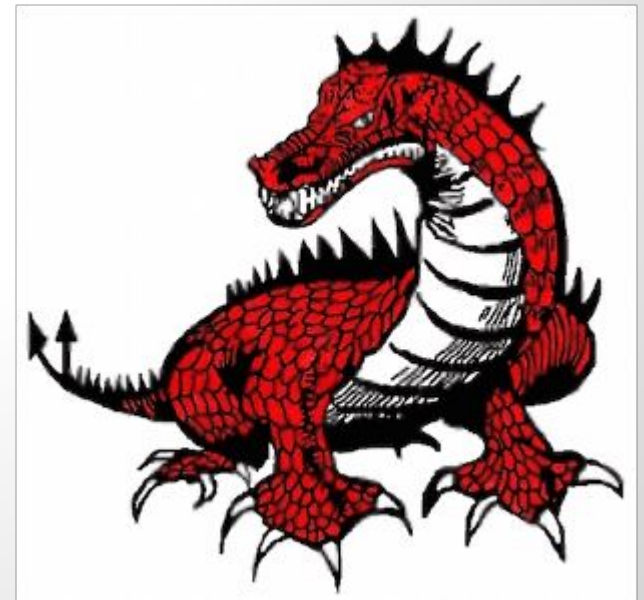

PTECFF's Big Give

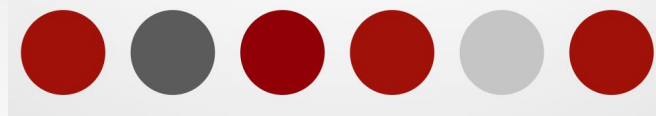

- I was asked if PPS wanted to be one of the recipients for the 2023 version of the PTECFF's Big Give
- I accepted this invitation and confirmed that donations would be used to help continue the construction of the PSC
- In 2022, PPS received \$30,600 from the Big Give!!! Those dollars will be allocated to help finish construction of the PSC

Thank You!!!

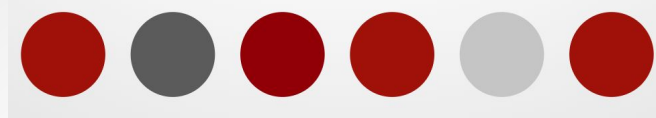

- Trevor Mullanix
- Volunteered back in July to seed areas at the Pendragon Sports Complex (areas in which Tony installed underground sprinklers)
- He donated the use of his equipment and time
- The grass is looking fantastic!!
- THANK YOU!!!

October Board of Education Meeting

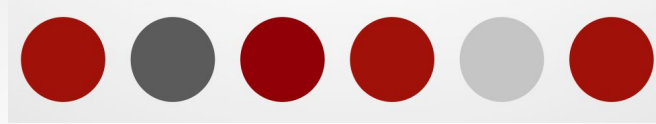

- Board goals review
- Powerschool (Ecollect, Enrollment Express)
- Negotiations preview and strategy session
- Approval of Audit
- LB 399 meeting (occurs before BOE meeting)

**It's a GREAT Day to be a
Pendragon!!!**

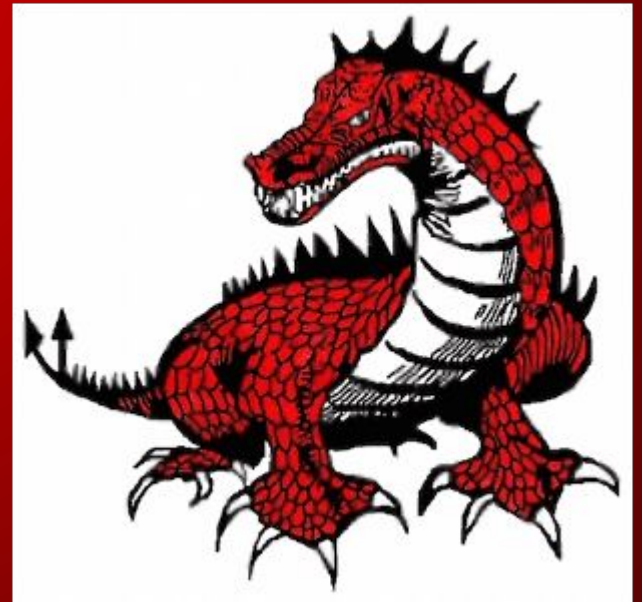

Elementary
Principal's Report

September 18, 2023

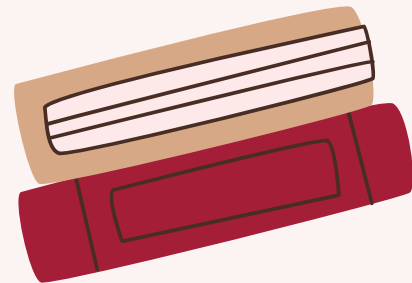
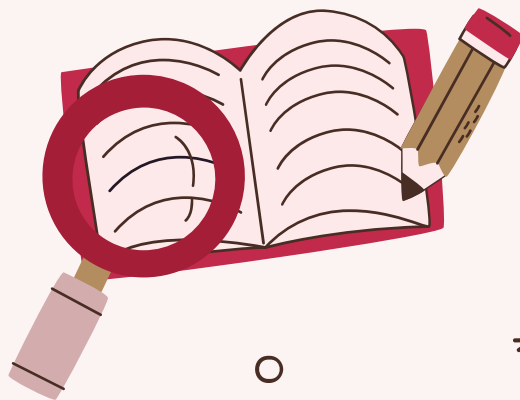
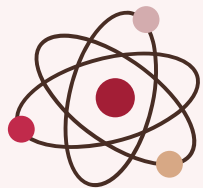
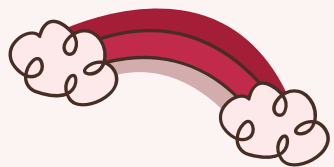







MISSION STATEMENT



The mission of the Pender Public School District is to provide quality educational opportunities in a safe, positive learning environment that motivates and challenges all students to become productive and responsible citizens.



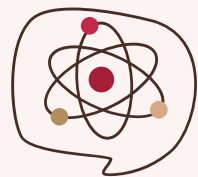

#BeEPIC



#BeEPIC

Make your story worth telling!

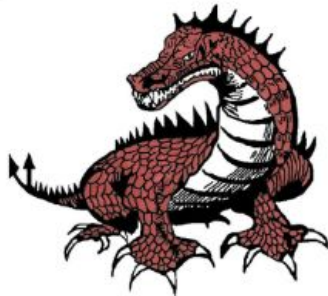

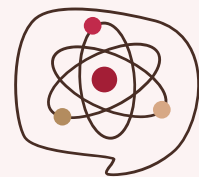

PROFESSIONAL IMPACT AREAS



01

CLIMATE

Create an EPIC environment for our staff and students.

02

ENGAGEMENT

Nobody gets to watch the parade.



03

LEADERSHIP

Be a better instructional leader by being in classrooms more consistently.

04

MY CHALLENGE TO MY STAFF

Take it personally.



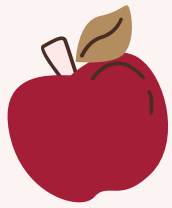

WORKSHOPS AND MEETINGS ATTENDED



PREVIOUS WORKSHOPS & MEETINGS

- 8.21 ESU #1 Principals Meeting
- 8.31 Collaborative Coaching Meetings
- 9.6 Monthly Paraprofessional Meeting



UPCOMING WORKSHOPS & MEETINGS

- 9.20 CPI Training for preschool staff
- 9.20 Title III Consortium Zoom
- 9.21 ESU #1 Principal's Zoom
- 9.25 NSCAS Roadshow - Norfolk
- 9.25 WSC PPC Meeting
- 10.4 Monthly Paraprofessional Meeting

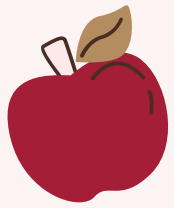

Professional Growth



- Teaching a night class at WSC
- Wednesday nights 5:30 - 8:15 p.m.
- SPD 332 - Special Education Law
- Good for me professionally to revisit that content
- Teaching college kids will ultimately make me a better teacher 😊





Class Sizes & Splits

- 3YO Preschool - 34 (Peters)
- 4YO Preschool - 25 (Garcia)
- Kindergarten - 26 (Bargholz/Kinning)
- 1st Grade - 27 (Bessmer/Jetensky)
- 2nd Grade - 22 (Dahlman/Mailloux)
- 3rd Grade - 22 (Hoffman/Gaer)
- 4th Grade - 39 (Nixon/Schrunk)
- 5th Grade - 32 (Arlt/English)
- 6th Grade - 31 (Krusemark/Tofflemire)

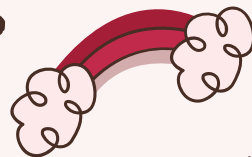



FALL BENCHMARKING



K-2 TESTING

- MAP Growth
- Aimsweb Plus
- Guided Reading Benchmarking



3-6 TESTING

- NSCAS Growth
- MAP Growth Science
- Guided Reading Benchmarking



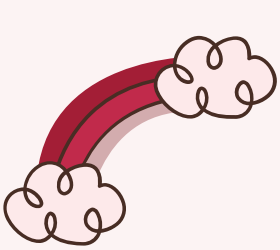

Wellness Wednesdays



- New addition for the 2023-2024 School Year
- 8:15-8:30 each Wednesday
- Rotation of Yoga, Nutrition & Aerobic Activity
- Dr. Karissa Johnson is helping me organize
- Casual dress for staff on Wednesday

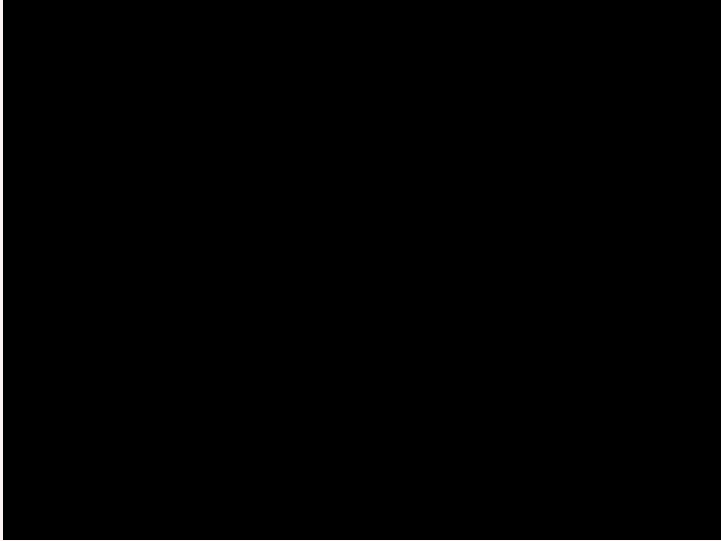

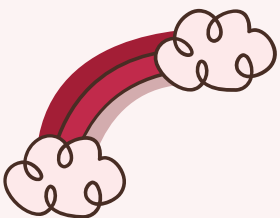

Nebraska All State Children's Chorus



3rd Annual Homecoming Teacher Switcheroo

switcheroo

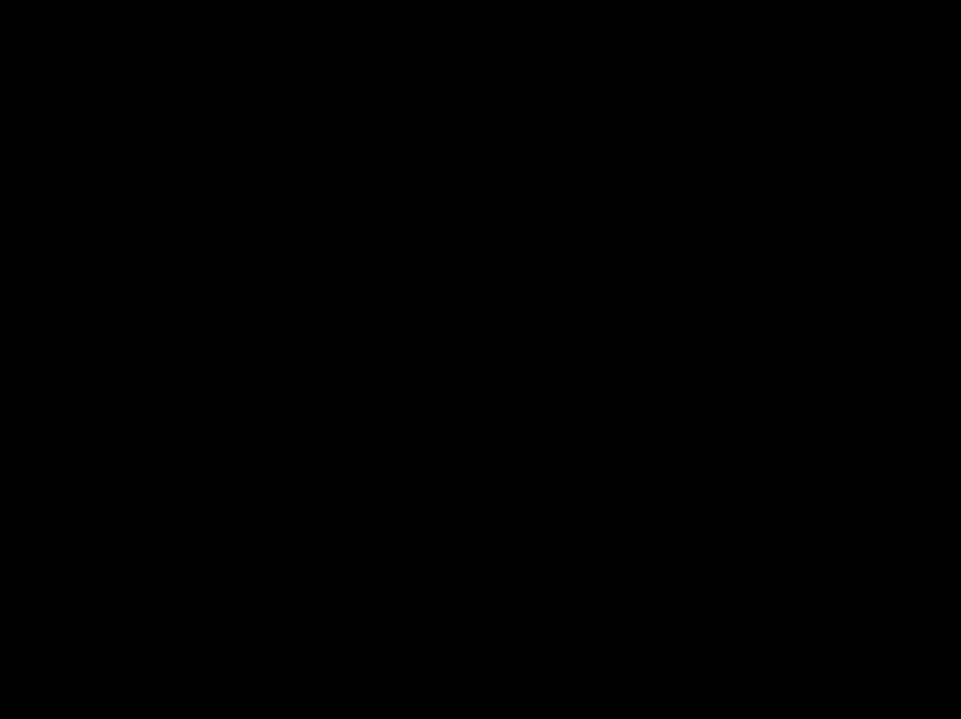
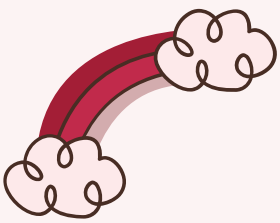



CARE CLOSET

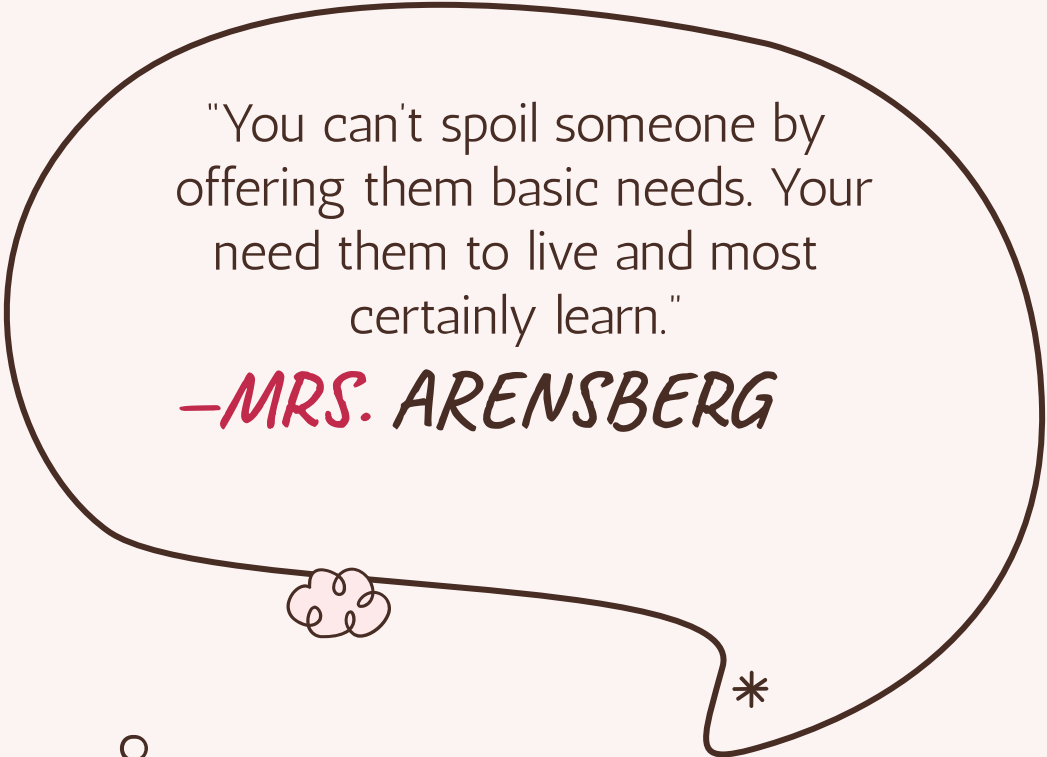

"You can't spoil someone by offering them basic needs. Your need them to live and most certainly learn."

-MRS. ARENSBERG



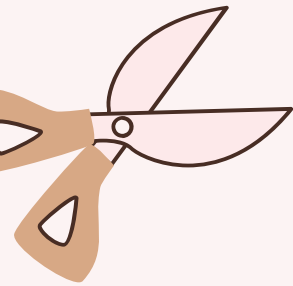
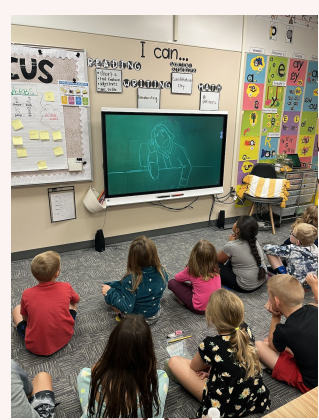

LB399

- ★ Dr. Martin Luther King, Jr.'s birthday (January 15, 1929)
- ★ Abraham Lincoln's birthday (February 12, 1809)
- ★ George Washington's birthday (February 22, 1732)
- ★ Memorial Day (May - the last Monday in May)
- ★ **Constitution Day (September 17 - every year)**
- ★ Veterans Day (November 11 - every year)
- ★ Thanksgiving Day (November - 4th Thursday in November)
- ★ Native American Heritage Day (November - the Friday after Thanksgiving)

For 4-5-6 Class today. We began by talking about things they knew about the Constitution. We then watched two videos on the Constitution and followed it up by playing Constitutional Compromise on [icivics.org](https://www.icivics.org)

Constitution Day - September 15, 2023

Today we celebrated Constitution Day by watching a video and working with our Social Studies reader that discussed Constitution Day. After our discussion the students signed a pledge that they would follow class rules and are taking it home to share with family. They also cut out their hands, signed them and put them next to our class pledge.



PRIDE Winners

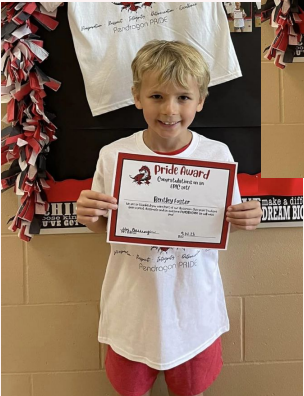
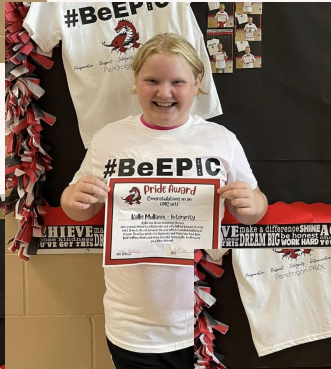
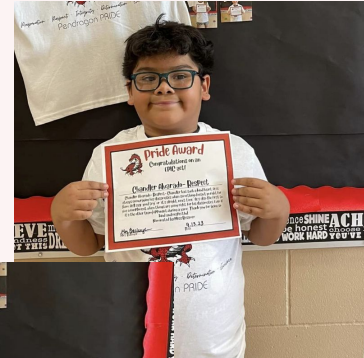
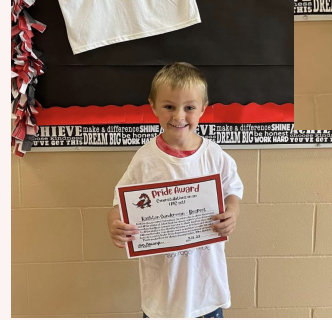
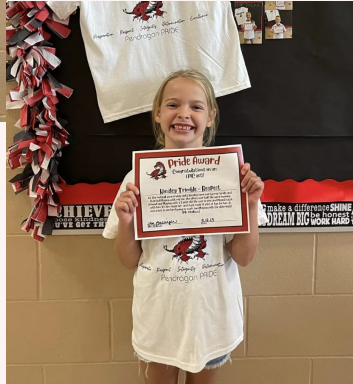
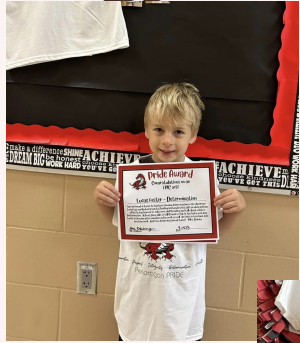
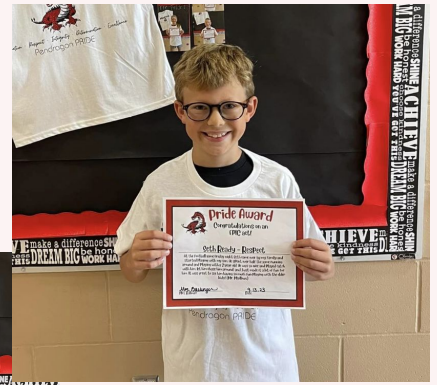
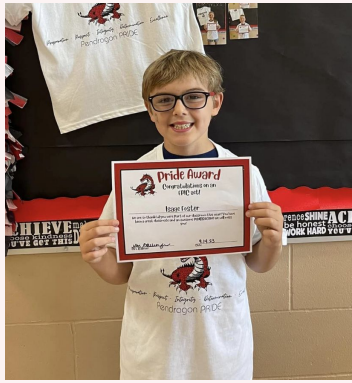

UPCOMING EVENTS

- Mon. September 18 - BOE Meeting
- Tues. September 19 - **BIG** Day 🎉
- Wed. September 20 - 2:30 Dismissal / Staff Development
- Wed. September 27 - Farm Safety Day
2:30 Dismissal / Staff Development
- Mon. October 2 - Collaborative Coaching
- Tues. October 3 - Picture Retakes
- Wed. October 4 - 2:30 Dismissal / Staff Development
- Wed. October 12 - 2:30 Dismissal / Staff Development
- Mon. October 16 - BOE Meeting
- Wed. October 18 - PT Conferences
- Friday, October 20 - No School

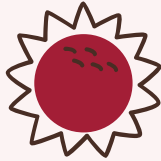
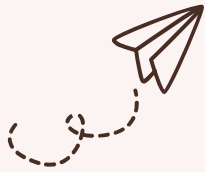



Woodhouse Ford
 2546 US 30
 Blair NE 68008
 (402) 426-4126

COUNTY Thurston		DATE (MONTH/DAY/YEAR) 09/18/2023
PURCHASER'S NAME Pender Public Schools		
STREET ADDRESS 609 Whitney St		
CITY Pender	STATE NE	ZIP 68047
RES. PHONE (402) 846-5432	CELL PHONE (402) 209-4559	BUS. PHONE (402) 846-5432
E-MAIL dswinton@walthillschool.org		

PLEASE ENTER MY ORDER FOR THE FOLLOWING: NEW USED YEAR: 2024 MAKE: Ford MODEL: Transit

SALES REP Tyler Channelear FINANCE MANAGER	SALES REP	BODY: 10-Passenger	COLOR: White	MILES:
VIN: ORDER OUT		STOCK NO.:		ORDER OUT

THIS PURCHASE DOES NOT INCLUDE PRODUCTS SUCH AS EXTENDED WARRANTY OR ACCESSORIES THAT ARE NOT REPRESENTED OR WARRANTED BY THE MANUFACTURER. THESE PRODUCTS ARE REPRESENTED AND WARRANTED BY THEIR OWN COMPANIES.

CUSTOMER INITIALS

PAYOFF VERIFICATION STATEMENT
 THE PAYOFF ON THE TRADE-IN VEHICLE IS ESTIMATED UPON PAYMENT VERIFICATION THE CUSTOMER WILL BE RESPONSIBLE FOR ANY AMOUNT ABOVE AND BEYOND: \$ _____

CUSTOMER INITIALS CUSTOMER INITIALS

NATIONAL CALL YES NO
 I/WE GIVE PERMISSION FOR A POTENTIAL BUYER OF THE TRADE VEHICLE(S) TO CONTACT ME/US:

Signed

THE PURCHASE AGREEMENT MAY BE CONDITIONED UPON ACCEPTANCE OR APPROVAL BY A 3RD PARTY FINANCIAL INSTITUTION. IF APPROVAL IS NOT OBTAINED FROM SAID INSTITUTION, THIS AGREEMENT AND RELATED DOCUMENTS ARE NULL AND VOID.

CUSTOMER INITIALS

ALL WARRANTIES, IF ANY, BY A MANUFACTURER OR SUPPLIER OTHER THAN DEALER ARE THEIRS, NOT DEALER'S, AND ONLY SUCH MANUFACTURER OR OTHER SUPPLIER SHALL BE LIABLE FOR PERFORMANCE UNDER SUCH WARRANTIES. UNLESS DEALER FURNISHES BUYER WITH SEPARATE WRITTEN WARRANTY OR SERVICE CONTRACT MADE BY DEALER ON ITS OWN BEHALF, DEALER HEREBY EXPRESSLY DISCLAIMS ALL WARRANTIES, EXPRESS OR IMPLIED, INCLUDING ANY IMPLIED WARRANTIES OF MERCHANTABILITY OR FITNESS FOR A PARTICULAR PURPOSE (A) ON ALL GOODS AND SERVICES SOLD BY DEALER AND (B) ON ALL USED VEHICLES WHICH ARE HEREBY SOLD "AS IS - NOT EXPRESSLY WARRANTED OR GUARANTEED"

AS IS
 THIS USED MOTOR VEHICLE IS SOLD AS IS WITHOUT ANY WARRANTY EITHER EXPRESSED OR IMPLIED. THE PURCHASER WILL BEAR THE ENTIRE EXPENSE OF REPAIRING OR CORRECTING ANY DEFECTS THAT PRESENTLY EXIST OR THAT MAY OCCUR IN THE VEHICLE.

BUYER'S SIGNATURE

I GUARANTEE THAT THE TITLE OF MY TRADE VEHICLE(S) IS NOT A SALVAGE TITLE AND THE VEHICLE NEVER HAS HAD A SALVAGE TITLE. I FURTHER STATE THAT ALL EMISSIONS EQUIPMENT AND ALL ORIGINAL SAFETY RESTRAINT EQUIPMENT INCLUDING BUT NOT LIMITED TO THE SAFETY BELTS OR AIR BAGS HAVE NOT BEEN ALTERED OR REMOVED WITHOUT BEING REPLACED AND ARE IN GOOD WORKING CONDITION. I WILL PAY TO REPAIR OR REPLACE THESE ITEMS INCLUDING AIR BAGS AND SEAT BELTS IF THEY ARE MISSING OR DO NOT WORK. THE SELLING DEALER MAY ELECT TO VOID THE SALE AND/OR ELECT TO COLLECT DAMAGES INCLUDING BUT NOT LIMITED TO DEALER'S EXPENSES AND LOST PROFIT(S) FOR THE DIFFERENCE IN VALUE HAD THE TITLE NOT BEEN SALVAGE.

BUYER'S SIGNATURE

CASH PRICE OF VEHICLE	\$

DOCUMENTATION FEE	\$
STATE AND LOCAL TAXES	\$
LICENSE, LICENSE TRANSFER, TITLE, REGISTRATION FEE	\$

TRADE VEH	YR	MAKE	MODEL
	ENG	TRANS	BODY
	MILES	COLOR	
	VIN		
1	BAL. OWED TO	R <input type="checkbox"/>	L <input type="checkbox"/>
TRADE VEH	YR	MAKE	MODEL
	ENG	TRANS	BODY
	MILES	COLOR	
	VIN		
2	BAL. OWED TO	R <input type="checkbox"/>	L <input type="checkbox"/>

ALLOWANCE DOWN PAYMENT	USED TRADE IN-ALLOWANCE	
	BALANCED OWED OR TRADE-IN	
	ALLOWANCE OR TRADE-IN (Applied Below)*	
	DOWN PAYMENT	
	and/or \$ rebates	
	and/or \$ rebates	
	and/or \$ rebates	
ALLOWANCE ON TRADE-IN (See Above for Details)		

TOTAL DOWN PAYMENT ALLOWANCE	\$
CASH BALANCE DUE ON DELIVERY	\$ 55,240

The front and back of this order comprise the entire agreement affecting this purchase and no other agreement or understanding of any nature concerning same has been made or entered into, or will be recognized. I hereby certify that no credit has been extended to me for the purchase of this motor vehicle except as appears in writing on the face of this agreement. I have read the matter printed on the back hereof and agree to it as a part of this order the same as if it printed above my signature. I certify that I am of legal age, and hereby acknowledge receipt of copy of this order.

09/18/2023
 PURCHASE'S SIGNATURE _____ CO-BUYER _____ DATE _____ ACCEPTED BY: _____ DEALER OR AUTHORIZED REPRESENTATIVE _____



Preview Order T88C - X2Y 350 Low Roof Pass RWD: Order Summary Time of Preview: 09/14/2023 16:28:16 Receipt: 9/14/2023

Dealership Name: Woodhouse Ford, Inc.

Sales Code : F53507

Dealer Rep.	Benjamin Huenink	Type	Retail	Vehicle Line	Transit	Order Code	T88C
Customer Name	X XXXXX	Priority Code	19	Model Year	2024	Price Level	415

DESCRIPTION	MSRP	DESCRIPTION	MSRP
X2Y0 T350 LR PASS XL RWD	\$53145	JOB #1 ORDER	\$0
148" WHEELBASE	\$0	CV LOT MANAGEMENT	\$0
OXFORD WHITE	\$0	FRONT LICENSE PLATE BRACKET	\$0
VINYL	\$0	9400# GVWR PACKAGE	\$0
DARK PALAZZO GRAY	\$0	2WAY DRV/PASS PALAZZO VINYL	\$0
PREFERRED EQUIPMENT PKG.301A	\$0	50 STATE EMISSIONS	\$0
.XL TRIM	\$0	MANUAL AIR CONDITIONER	\$0
3.5L PFDI V6 (GAS)	\$0	E-85 FLEX FUEL CAPABLE	\$0
.10-SPEED TRANSMISSION	\$0	FUEL CHARGE	\$0
.235/65R16C BSW ALL-SEASON	\$0	PRICED DORA	\$0
3.73 NON-LIMITED SLIP AXLE	\$0	DESTINATION & DELIVERY	\$2095
TOTAL BASE AND OPTIONS			MSRP \$55240
DISCOUNTS			NA
TOTAL			\$55240

Customer Name:
Customer Address:

Customer Email:
Customer Phone:

Customer Signature _____ Date _____

This order has not been submitted to the order bank.

This is not an invoice.



Johnson Fitness & Wellness

Dave King (4422)
 4511 South 119th Circle
 Omaha, NE 68137
 Phone: (402) 515-4427
 Fax: () -
 Email: dave.king@johnsonfit.com

Quote

Quote Order **243-001560**
 Date **09/12/23**

Ship To Information

Pender High School
 Anthony Ferg
 609 Whitney Street
 Pender, NE 68047

Work: (402) 385-3244

Email: anferg1@penderschools.org

Bill To Information

Pender High School
 Accounts Payable
 609 Whitney St
 Pender, NE 68047

Work: (402) 385-3244

Email: dehansel1@penderschools.org

Expiration Date: 10/12/2023

Terms: Prepaid

Qty	SKU	Description	Delivery Method	Tax	Your Price	Ext. Price
2	NO-CURVE TRAINER	WOODWAY CURVE TRAINER NON MOTORIZED TREADMILL	Deliver	<input type="checkbox"/>	\$4,950.00	\$9,900.00
				<input type="checkbox"/>		
1		Factory Freight		<input type="checkbox"/>	\$300.00	\$300.00
1		Install Labor	Deliver	<input type="checkbox"/>	\$175.00	\$175.00

Special Instructions:

(2) CURVE TRAINERS

Item Total:	\$10,375.00
Tax:	\$0.00
TOTAL:	\$10,375.00

Standard Terms and Conditions

1. All orders must be prepaid before shipment without approved credit.
2. These prices are subject to change after 30 days from document date.
3. There will be a 1.5% monthly service charge on all overdue accounts. The buyer is also responsible for any collection and/or legal fees involved in collecting past due accounts.
4. Any changes on orders must be made within 7 days after the order is accepted.
5. Clerical errors subject to correction. All prices and agreements are contingent upon strikes, accidents, and other causes avoidable or beyond our control.
6. Buyer agrees to promptly file claim for all goods damaged in transit.
7. There will be a 25-35% restocking charge on merchandise ordered but not accepted. Special orders are not refundable. Delivery, Set-Up and Freight charges will not be refunded.
8. A Preventative Maintenance Agreement is available for all equipment.
9. Equipment lease is available with approved credit.
10. All unit prices are F.O.B. manufacturer.
11. Products purchased without commercial warranties that are placed in non-residential settings void manufacturer's warranty. All repair costs are customer's responsibility.

Please send check payments to:
DBA Johnson Fitness & Wellness
1600 Landmark Drive
Cottage Grove, WI 53527

Acceptance of Proposal:

These prices, specifications and conditions are satisfactory and are hereby accepted.
I am authorized to order the listed equipment with full understanding
of the payment terms.

Authorized Signature: _____

Print Name: _____

P.O. Number: _____

Date of Acceptance: _____

www.johnsonfit.com/commercial

PENDER PUBLIC SCHOOL SPORTS COMPLEX BUILDING PENDER, NEBRASKA

For Review Only
NOT FOR CONSTRUCTION

SEPTEMBER 15, 2023

PROJECT TEAM

CIVIL

OLSSON
1707 DAKOTA AVENUE
SOUTH SIOUX CITY, NE 68776
O 402.494.3059

ARCHITECTS

PETERS & ASSOCIATES, ARCHITECTS,P.C.
1103 GALVIN ROAD SOUTH, SUITE E
BELLEVUE, NE 68005
402-895-2292

STRUCTURAL ENGINEERS

TIMBERLYNE
116 W 1st St
WAYNE, NE 68787
888-489-1680

MECHANICAL AND ELECTRICAL

OLSSON
601 P STREET, SUITE 200
LINCOLN, NE 68508
O 402.474.6311

INDEX OF DRAWINGS

COVER COVER, INDEX OF DRAWINGS, PROJECT TEAM

Civil

- C.1 AERIAL LAYOUT
- C.2 SITE PLAN
- C.3 EROSION CONTROL
- C.4 GRADING PLAN
- C.5 UTILITIES PLAN

Architectural

- A-1.1 CODE PLAN
- A-1.2 FLOOR PLAN
- A-1.3 LOFT FLOOR PLAN
- A-1.4 REFLECTED CEILING PLANS AND ROOF PLAN, ROOM FINISH SCHEDULE AND DETAILS
- A-2.1 INTERIOR ELEVATIONS AND DETAILS, TOILET ACCESSORY SCHEDULE
- A-2.2 INTERIOR ELEVATION AND DETAILS
- A-3.1 ELEVATIONS
- A-3.2 ELEVATIONS
- A-4.1 STAIR SECTION AND DETAILS
- A-6.1 DOOR AND FRAME TYPES, WINDOW TYPES
- A-7.1 BUILDING SECTIONS

Structural/ Timberlyne Building

- S1 COVER SHEET
- S2 EXTERIOR ELEVATIONS
- S3 EXTERIOR ELEVATIONS SECTION VIEWS
- S4 MAIN FLOOR LAYOUT
- S6 LOFT FLOOR LAYOUT
- S7 FOUNDATION PLAN
- S8 FOUNDATION DETAILS
- S9 BENT DETAILS PLATE JOINERY
- S10 BENT DETAILS
- S11 BENT DETAILS
- S12 BENT FRAME ISO
- S13 BENT LAYOUT POST CONNECTIONS
- S14 LOFT FRAMING PLAN
- S15 ROOF FRAMING PLAN
- S16 PURLIN LAYOUTS
- S17 ROOF FRAME ISO
- S18 BUILDING SECTION
- S19 BUILDING SECTION
- S20 BUILDING SECTIONS
- S21 ATTACHMENT DETAILS
- S22 FLASHING DETAILS
- S23 MAIN SHEAR WALL SCHEDULE
- S24 LOFT SHEAR WALL SCHEDULE

Mechanical/ Electrical

- M 101 PLUMBING PLAN
- M 102 WASTE RISER DIAGRAM

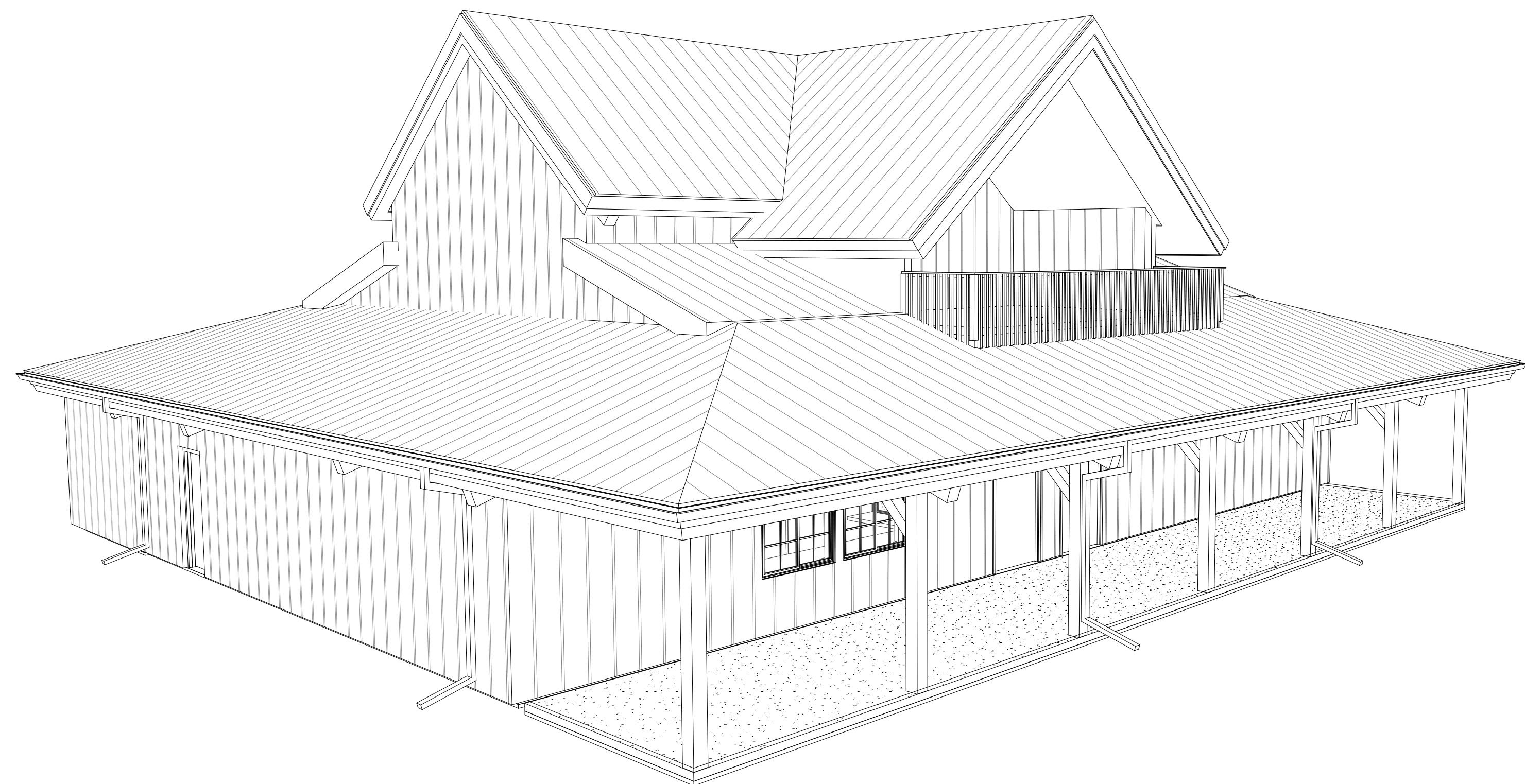

SYMBOLS

	ROOM NAME/ ROOM		DETAIL
	ELEVATION		BUILDING ELEVATION
	WALL		INTERIOR ELEVATION
	DOOR		SECTION
	WINDOW		DETAIL PLAN
	DEMOLITION NOTE		REVISION
	KITCHEN EQUIPMENT		
	NORTH		

REVISIONS
SEPTEMBER 15, 2023
PROJECT #: 23-01

COVER, INDEX OF DRAWINGS,
PROJECT TEAM

PENDER PUBLIC SCHOOLS
SPORTS COMPLEX BUILDING
PENDER, NEBRASKA

PETERS & ASSOCIATES
ARCHITECTS, P.C.
1103 GALVIN ROAD SOUTH, SUITE E
BELLEVUE, NEBRASKA 68005
PHONE: 402-895-2292

FOR REVIEW ONLY
NOT FOR CONSTRUCTION

COVER

I, Jesse J. McComell, am the
Coordinating Professional on
the PENDER PUBLIC SCHOOLS
SPORTS COMPLEX BUILDING
Project.

COPYRIGHT 2023
PETERS AND ASSOCIATES ARCHITECTS P.C.
THESE DOCUMENTS ARE ISSUED BY PETERS
AND ASSOCIATES ARCHITECTS P.C. AND ARE
PROTECTED BY COPYRIGHT LAW. THEY MAY
NOT BE REPRODUCED OR DUPLICATED IN
WHOLE OR IN PART WITHOUT EXPRESS
WRITTEN PERMISSION OF PETERS AND
ASSOCIATES ARCHITECTS P.C., BELLEVUE, NE.



REVISIONS	AUGUST 1, 2023	PROJECT #: 23-04
-----------	----------------	------------------

AERIAL LAYOUT

**PENDER PUBLIC SCHOOLS
SPORTS COMPLEX BUILDING
PENDER, NEBRASKA**

**PETERS & ASSOCIATES
ARCHITECTS, P.C.**
 1103 GALVIN ROAD SOUTH, SUITE E 68005
 BELLEVUE, NEBRASKA 402-865-2292
 PHONE:



For Review Only
NOT FOR CONSTRUCTION

olsson

Engineering - Nebraska COA #CA-0638
 1707 Dakota Avenue
 South Sioux City, NE 68776-2356 TEL 402.494.3059 www.olsson.com

COPYRIGHT 2023
 PETERS AND ASSOCIATES ARCHITECTS P.C. THESE DOCUMENTS ARE ISSUED BY PETERS AND ASSOCIATES ARCHITECTS P.C. AND ARE PROTECTED BY COPYRIGHT LAW. THEY MAY NOT BE REPRODUCED OR DUPLICATED IN WHOLE OR IN PART WITHOUT EXPRESS WRITTEN PERMISSION OF PETERS AND ASSOCIATES ARCHITECTS P.C., BELLEVUE, NE.

CONSTRUCTION NOTES:

1. ANY TRAFFIC CONTROL DEVICES OR SAFETY EQUIPMENT NEEDED TO CONSTRUCT THIS PROJECT SHALL BE THE RESPONSIBILITY OF THE CONTRACTOR. ALL ITEMS NECESSARY TO MAINTAIN TRAFFIC SHALL BE CONSIDERED SUBSIDIARY TO THE PROJECT. ALL TRAFFIC CONTROL ITEMS SHALL BE IN ACCORDANCE WITH THE MOST CURRENT EDITION OF THE MANUAL UNIFORM TRAFFIC CONTROL DEVICES (MUTCD).
2. THE CONTRACTOR SHALL PROTECT THE EXISTING SPRINKLER HEADS AND LINES. THE CONTRACTOR SHALL REPAIR ALL DAMAGED SPRINKLER SYSTEMS. THIS WORK SHALL BE CONSIDERED SUBSIDIARY TO THE PROJECT.
3. ALL SAW CUTS SHALL BE CONSIDERED SUBSIDIARY TO REMOVAL QUANTITIES.
4. THE LOCATION OF ALL AERIAL AND UNDERGROUND UTILITIES MAY NOT BE INDICATED ON THESE PLANS. THE CONTRACTOR SHALL VERIFY THE LOCATION (INCLUDING DEPTH OR HEIGHT) OF ALL UTILITIES BEFORE CONSTRUCTION. UNDERGROUND UTILITIES, INDICATED OR NOT, WILL BE LOCATED AND FLAGGED BY THE UTILITIES AT THE REQUEST OF THE CONTRACTOR. NO EXCAVATION WILL BE PERMITTED IN THE AREA OF THE UNDERGROUND FACILITIES UNTIL ALL SUCH FACILITIES HAVE BEEN LOCATED AND IDENTIFIED TO THE SATISFACTION OF ALL PARTIES. THE EXCAVATION MUST BE ACCOMPLISHED WITH EXTREME CARE IN ORDER TO AVOID ANY POSSIBILITY OF DAMAGE TO THE UTILITY FACILITY.
5. THE CONTRACTOR SHALL USE EXTREME CAUTION IN THE AREA OF ALL EXISTING UTILITIES, AND SHALL BE RESPONSIBLE FOR ANY DAMAGES. THE CONTRACTOR SHALL NOTIFY THE ENGINEER IMMEDIATELY OF ANY DAMAGE TO EXISTING UTILITIES.
6. THE CONTRACTOR SHALL OBTAIN ALL REQUIRED PERMITS AND SHALL PAY THE COST OF ALL FEES.
7. THE CONTRACTOR SHALL PRESERVE ALL PROPERTY CORNER MONUMENTS. PROPERTY CORNERS DISTURBED DURING CONSTRUCTION SHALL BE RESET BY A REGISTERED LAND SURVEYOR AT THE CONTRACTOR'S EXPENSE.
8. ALL SURFACES THAT ARE DISTURBED DURING CONSTRUCTION SHALL BE RESTORED TO PRE-CONSTRUCTION CONDITION. THIS WORK SHALL BE CONSIDERED INCIDENTAL AND NO MEASUREMENT OR PAYMENT SHALL BE MADE.
9. PRIOR TO MOVING OFF THE JOB, THE CONTRACTOR SHALL NOTIFY THE ENGINEER FOR A FINAL WALK-THROUGH OF THE PROJECT. THE CONTRACTOR SHALL CONDUCT THE FINAL WALK-THROUGH WITH THE ENGINEER AND CITY.
10. REFER TO STRUCTURAL PLAN FOR STOOP AND FOUNDATION DETAILS.
11. ADA PARKING HAS NOT BEEN INCLUDED IN THE TEMPORARY PARKING FOR THIS PHASE OF THIS PROJECT (CONSTRUCTING THE SHELL OF THE BUILDING). PERMANENT PARKING AND ADA STALLS WILL BE INCLUDED IN A FUTURE PHASE THAT WILL HAPPEN BEFORE OR CONCURRENTLY OF THE FULL BUILD OUT OF THE PROPOSED TIMBERLYNE BUILDING.

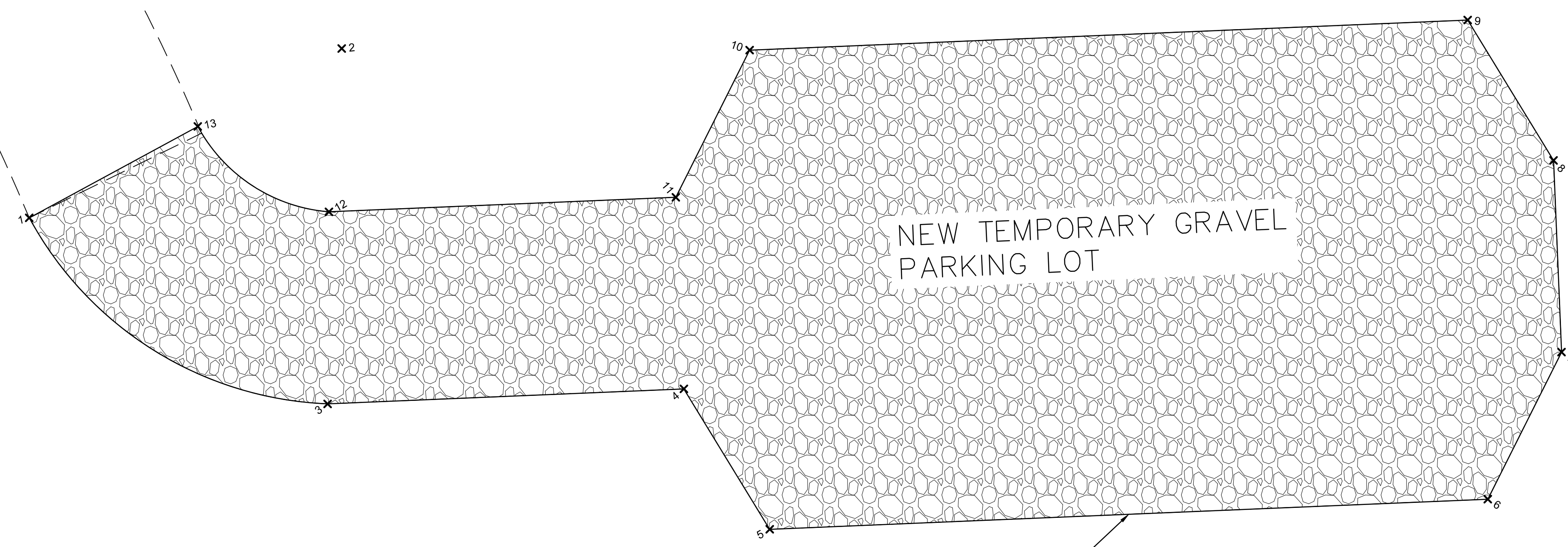

1" PREFORMED EXPANSION JOINT FILLER W/URETHANE SEALANT
SLOPE AWAY FROM BUILDING

GRAVEL SHALL MEET THE FOLLOWING GRADATION REQUIREMENTS:

SIEVE SIZE	% PASSING
1"	100
#4	61-95
#10	0-30
#20	0-6

CRUSHED ROCK SHALL MEET THE FOLLOWING GRADATION REQUIREMENTS:

SIEVE SIZE	% PASSING
1"	100
#4	20-60
#10	0-30
#20	0-10

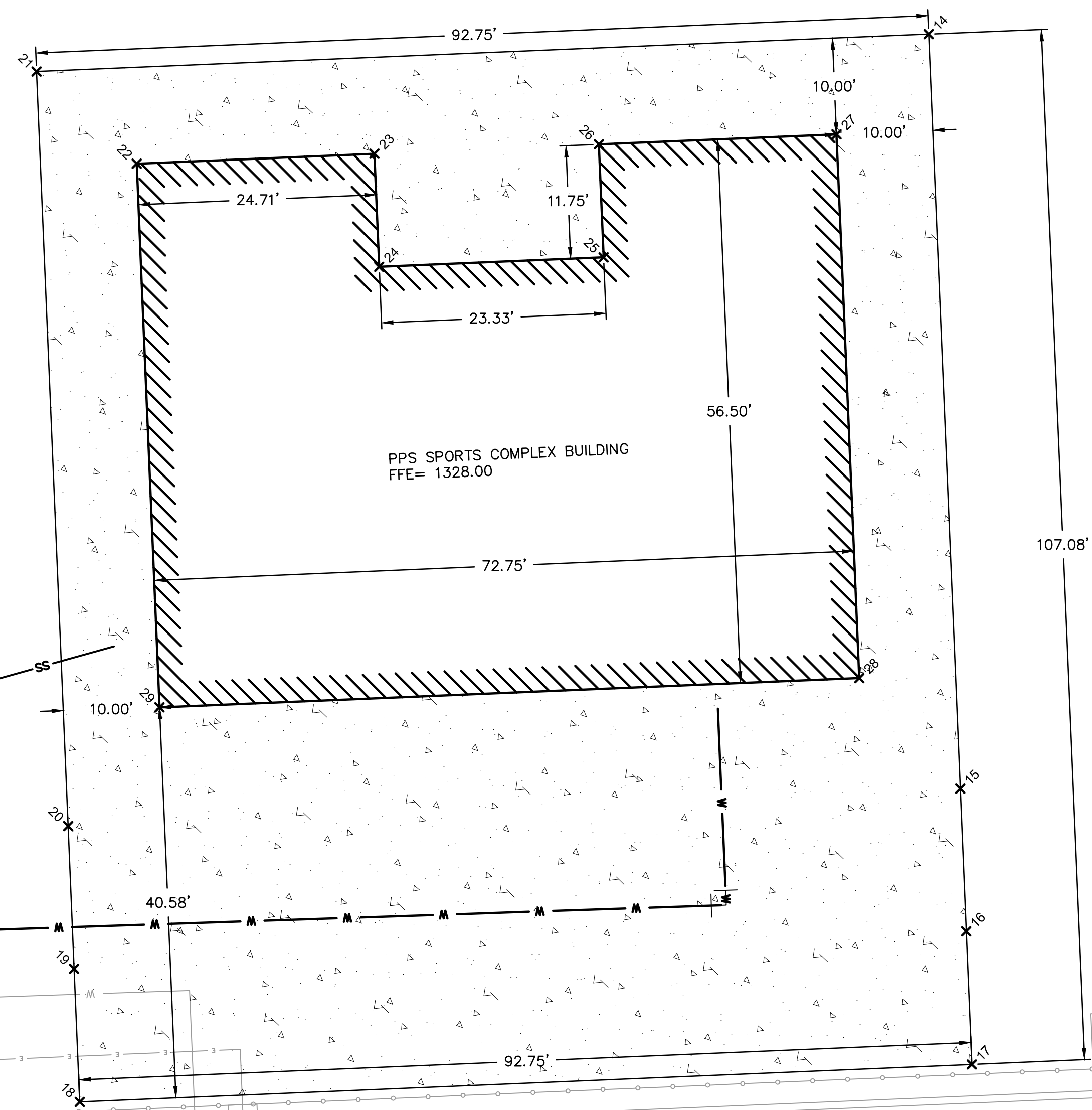

POINT TABLE				
POINT #	NORTHING	EASTING	ELEVATION	FULL DESCRIPTION
1	848049.7812	2531150.3294	1326.120	EDGE OF ROCK PC
2	848088.9125	2531129.1399	1325.980	EDGE OF ROCK 44.5' AND 20.5' R
3	848087.1403	2531173.6046	1326.020	EDGE OF ROCK PT
4	848131.7549	2531171.7347	1325.980	EDGE OF ROCK
5	848142.4999	2531189.3002	1325.990	EDGE OF ROCK
6	848232.4210	2531185.5314	1325.800	EDGE OF ROCK
7	848241.6585	2531167.1285	1325.680	EDGE OF ROCK
8	848240.6535	2531143.1495	1325.640	EDGE OF ROCK
9	848229.9085	2531125.5841	1325.720	EDGE OF ROCK
10	848139.9874	2531129.3528	1325.890	EDGE OF ROCK
11	848130.7499	2531147.7558	1325.950	EDGE OF ROCK
12	848087.3037	2531149.5767	1326.000	EDGE OF ROCK PC
13	848070.8857	2531138.9014	1326.030	EDGE OF ROCK PT
14	848229.0381	2531210.5729	1327.720	SIDEWALK-TOP OF SLAB
15	848232.3218	2531288.9207	1327.700	SIDEWALK-TOP OF SLAB
16	848232.9429	2531303.7411	1327.250	SIDEWALK-TOP OF SLAB
17	848233.5222	2531317.5623	1327.660	SIDEWALK-TOP OF SLAB
18	848140.8535	2531321.4462	1327.700	SIDEWALK-TOP OF SLAB
19	848140.2743	2531307.6250	1327.700	SIDEWALK-TOP OF SLAB
20	848139.6531	2531292.8046	1327.700	SIDEWALK-TOP OF SLAB
21	848136.3694	2531214.4568	1327.720	SIDEWALK-TOP OF SLAB
22	848146.7794	2531224.0292	1328.000	BUILDING FFE
23	848171.4713	2531222.9944	1328.000	BUILDING FFE
24	848171.9634	2531234.7341	1328.000	BUILDING FFE
25	848195.2762	2531233.7570	1328.000	BUILDING FFE
26	848194.7842	2531222.0173	1328.000	BUILDING FFE
27	848219.4656	2531220.9828	1328.000	BUILDING FFE
28	848221.8315	2531277.4333	1328.000	BUILDING FFE
29	848149.1454	2531280.4797	1328.000	BUILDING FFE

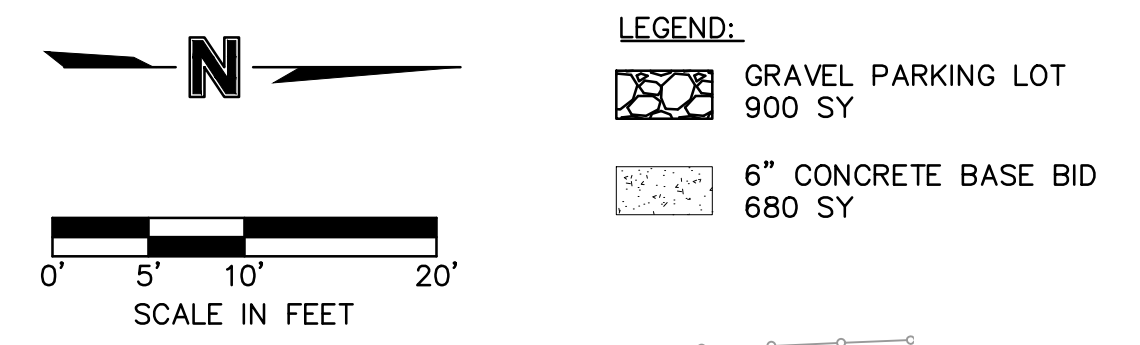

olsson

Engineering - Nebraska COA #CA-0638
1707 Dakota Avenue
South Sioux City, NE 68776-2356 TEL 402.494.3059 www.olsson.com

COPYRIGHT 2023
PETERS AND ASSOCIATES ARCHITECTS P.C.
THESE DOCUMENTS ARE ISSUED BY PETERS
AND ASSOCIATES ARCHITECTS P.C. AND ARE
PROTECTED BY COPYRIGHT LAW. THEY MAY
NOT BE REPRODUCED OR DUPLICATED IN
WHOLE OR IN PART WITHOUT EXPRESS
WRITTEN PERMISSION OF PETERS AND
ASSOCIATES ARCHITECTS P.C., BELLEVUE, NE.

For Review Only
NOT FOR CONSTRUCTION

STORMWATER MANAGEMENT AND EROSION/SEDIMENT CONTROL NOTES:

1. THE CONTRACTOR SHALL CONTINUOUSLY PROVIDE ADEQUATE STORMWATER MEASURES IN ACCORDANCE WITH THE EROSION CONTROL PLAN.
2. THE CONTRACTOR SHALL BE RESPONSIBLE FOR KEEPING THE PUBLIC STREETS, ACCESS ROUTES, AND WATERWAYS IN THE VICINITY OF THE JOB SITE CLEAN AND FREE OF ROCKS, SOIL AND DEBRIS.
3. THE CONTRACTOR SHALL INSTALL EROSION AND SEDIMENTATION CONTROL 'BEST MANAGEMENT PRACTICES' (BMPs) PRIOR TO ANY SITE PREPARATION WORK (E.G., CLEARING, GRUBBING, DEMOLITION, OR EXCAVATION).
4. APPROVED EROSION AND SEDIMENT CONTROL BMPs SHALL BE MAINTAINED AND KEPT IN GOOD REPAIR FOR THE DURATION OF THIS PROJECT. UNLESS OTHERWISE REQUIRED BY THE STATE'S CONSTRUCTION STORMWATER PERMIT, AT A MINIMUM THE INSPECTOR SHALL INSPECT ALL BMPs EVERY 14 DAYS, AND AFTER ALL SIGNIFICANT PRECIPITATION EVENTS I.E. RAINFALL, SNOWMELT. ACCUMULATED SEDIMENT AND CONSTRUCTION DEBRIS SHALL BE REMOVED WEEKLY FROM ALL BMPs, OR AT ANY TIME THAT SEDIMENT OR CONSTRUCTION DEBRIS ADVERSELY IMPACTS THE FUNCTIONING OF THE BMPs.
5. TOPSOIL AND SUITABLE EARTHEN MATERIALS SHALL BE SEGREGATED AND STOCKPILED WITHIN THE LIMITS OF CONSTRUCTION FOR USE ON AREAS TO BE FILLED AND RE-VEGETATED. ANY AND ALL STOCKPILES SHALL BE PLACED IN AN APPROVED LOCATION AND PROTECTED FROM EROSION ELEMENTS
6. SOILS THAT WILL BE STOCKPILED FOR MORE THAN THIRTY (30) DAYS SHALL BE MULCHED AND SEEDED WITH A TEMPORARY OR PERMANENT GRASS COVER WITHIN FOURTEEN (14) DAYS OF STOCKPILE CONSTRUCTION.
7. ANY SETTLEMENT OR SOIL ACCUMULATIONS BEYOND THE LIMITS OF CONSTRUCTION DUE TO GRADING OR EROSION SHALL BE REPAIRED IMMEDIATELY BY THE CONTRACTOR. THE CONTRACTOR SHALL BE HELD RESPONSIBLE FOR REMEDIATION OF ANY ADVERSE IMPACTS TO ADJACENT WATERWAYS, WETLANDS, PROPERTIES, ETC. RESULTING FROM WORK DONE AS PART OF THIS PROJECT.
8. A WATER SOURCE MUST BE AVAILABLE ON SITE DURING EARTHWORK OPERATIONS AND UTILIZED AS REQUIRED TO MINIMIZE DUST FROM EARTHWORK EQUIPMENT AND WIND. WATER USED ON SITE SHALL BE CONSIDERED SUBSIDIARY TO THE PROJECT.
9. THE CONTRACTOR MUST KEEP ALL POLLUTANTS, INCLUDING SEDIMENT, CONSTRUCTION DEBRIS, AND TRENCH BACKFILL MATERIALS FROM ENTERING THE STORM SEWER SYSTEM.
10. ALL SPILLS INCLUDING, BUT NOT LIMITED TO, PETROLEUM PRODUCTS, SOLVENTS, AND CEMENT SHALL BE CLEANED UP IMMEDIATELY. THE LOCAL CITY/COUNTY AND STATE'S GOVERNING AUTHORITY SHALL BE NOTIFIED IMMEDIATELY.
11. THE CONTRACTOR SHALL ENSURE THAT ALL LOADS OF CUT AND FILL MATERIAL IMPORTED TO OR EXPORTED FROM THE SITE SHALL BE PROPERLY COVERED TO PREVENT LOSS OF THE MATERIAL DURING TRANSPORT ON PUBLIC RIGHT-OF-WAY. ALL MATERIAL EXPORTED FROM THE SITE SHALL BE DISPOSED OF AT A SITE PERMITTED TO ACCEPT SUCH MATERIAL.
12. THE USE OF REBAR, STEEL STAKES OR STEEL FENCE POSTS FOR STAKING DOWN STRAW OR HAY BALES, OR TO SUPPORT SILT FENCING USED AS AN EROSION CONTROL MEASURE, IS PROHIBITED.
13. PHASING OF BMP'S: CONTRACTOR SHALL INSTALL THE CONSTRUCTION ENTRANCE, & ALL SILT FENCE PRIOR TO ANY CONSTRUCTION. SEEDING SHALL BE INSTALLED AT THE TAIL END OF THE PROJECT FOR FINAL STABILIZATION. PHASE ONE (TEMPORARY) BMP'S SHALL BE REMOVED ONCE FINAL STABILIZATION HAS OCCURRED.

GRADING NOTES:

1. PRIOR TO ANY GRADING OPERATIONS, ALL EROSION AND SEDIMENT CONTROL DEVICES SHALL BE ADEQUATELY IN PLACE. REFER TO THE GRADING & EROSION CONTROL PLAN SHEET FOR REQUIREMENTS.
2. THE CONTRACTOR SHALL FINISH GRADE SLOPES AS SHOWN NO STEEPER THAN ONE FOOT VERTICAL IN SIX FEET HORIZONTAL.
3. CONTRACTOR SHALL GRADE LANDSCAPED AREAS TO PROVIDE POSITIVE DRAINAGE AWAY FROM BUILDINGS AND SIDEWALKS WHEN FINISH LANDSCAPE MATERIALS ARE IN PLACE.
4. ALL HERBACEOUS VEGETATION AND TOPSOIL SHALL BE STRIPPED TO A MINIMUM DEPTH OF 6 INCHES, SEGREGATED, AND STOCKPILED WITHIN THE LIMITS OF CONSTRUCTION FOR USE ON AREAS TO BE RE-VEGETATED.
5. ALL EXISTING PAVEMENT, UTILITIES, BURIED DEBRIS, RUBBLE, AND/OR STRUCTURES/FOUNDATIONS ENCOUNTERED WITHIN AREAS OF DISTURBANCE SHALL BE COMPLETELY REMOVED PRIOR TO OR DURING EARTHWORK OPERATIONS. WASTED MATERIAL SHALL NOT BE BURIED ONSITE WITHOUT THE PRIOR APPROVAL OF THE OWNER.
6. SUITABLE FILL MATERIALS SHALL BE PLACED IN THIN LIFTS OF 4 TO 8 INCHES LOOSE MEASUREMENT, AND SHALL BE COMPACTED TO A MINIMUM 95% OF THE MAXIMUM STANDARD PROCTOR DENSITY (PER ASTM D698) AT A MOISTURE CONTENT OF -2% TO +2%.
7. IF REQUIRED, THE CONTRACTOR SHALL OBTAIN ALL LOCAL AND STATE PERMITS AND AUTHORIZATION TO DISCHARGE FROM DEWATERING ACTIVITIES.
8. CONTRACTOR WILL BE HELD RESPONSIBLE FOR SETTLEMENT DUE TO IMPROPER COMPACTION.
9. THE CONTRACTOR SHALL NOTIFY THE OWNER/ENGINEER IMMEDIATELY IF ANY GRADING WILL TAKE PLACE BEYOND THE LIMITS OF DISTURBANCE.
10. ANY GEOTECHNICAL/TESTING REPORTS SOLICITED BY THE CONTRACTOR SHALL BE SUBMITTED TO THE OWNER AND THE ENGINEER.
11. GRADING TOLERANCES: PAVED AREAS -0.0' TO +0.2'; ALL OTHER AREAS: -0.2' TO +0.2'.
12. EARTHWORK WILL BE BID AS LUMP SUM. QUANTITIES IN EARTHWORK TABLE ARE APPROXIMATE AND FOR INFORMATIONAL PURPOSES ONLY. NO ADJUSTMENTS WILL BE MADE FOR PAYMENT.

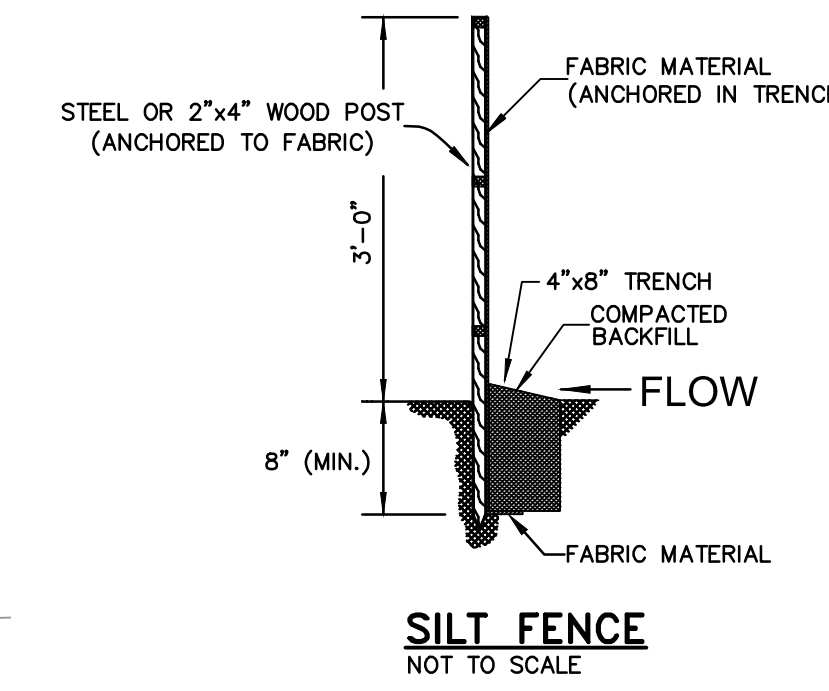
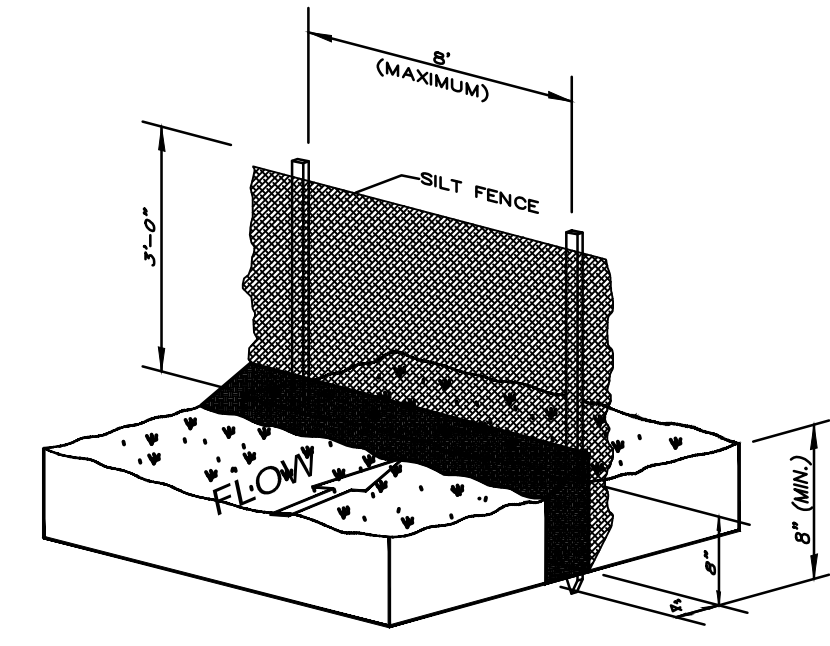
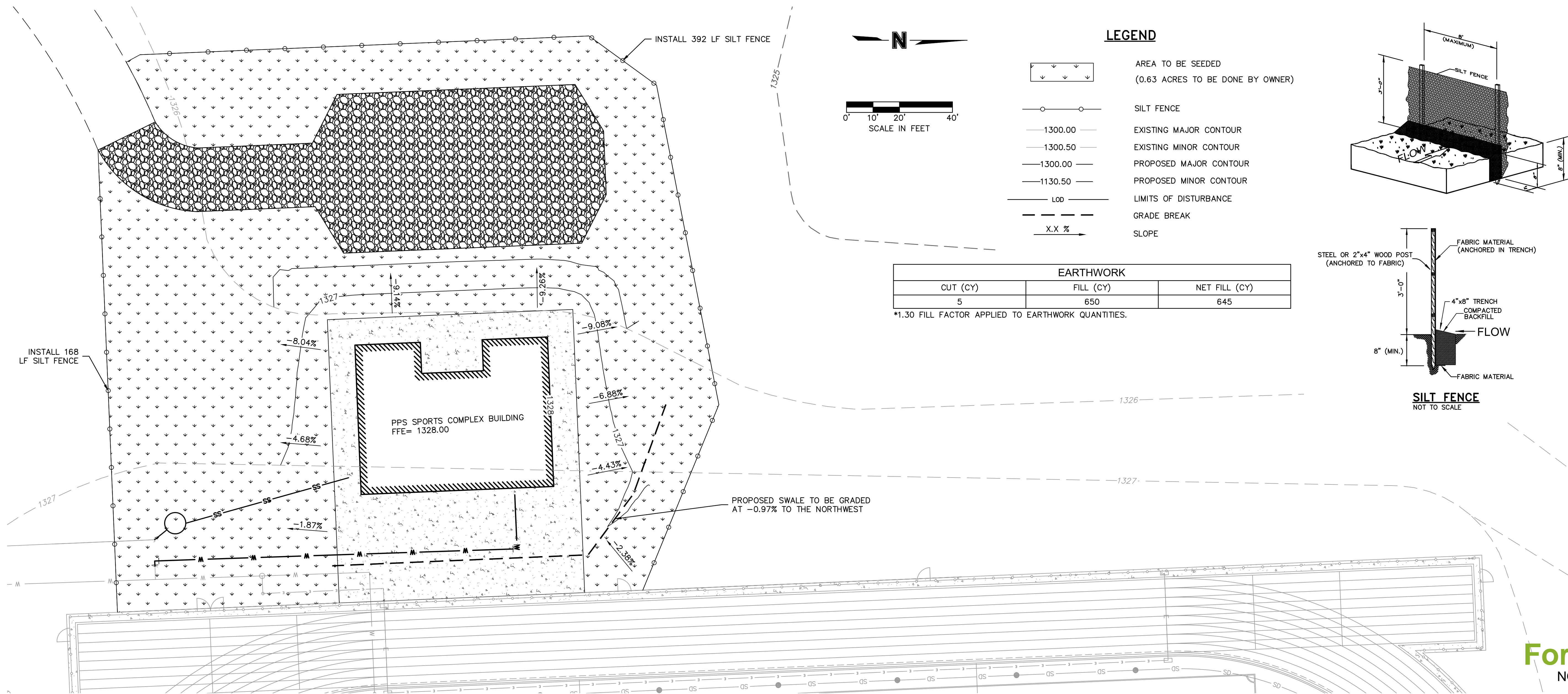

REVISIONS

AUGUST 1, 2023

PROJECT #: 23-04

EROSION CONTROL

**PENDER PUBLIC SCHOOLS
SPORTS COMPLEX BUILDING**

PENDER, NEBRASKA

**PETERS & ASSOCIATES
ARCHITECTS, P.C.**

SUITE E
1103 GALVIN ROAD SOUTH,
BELLEVUE, NEBRASKA 68005
PHONE: 402-885-8282

PROFESSIONAL CIVIL ENGINEER

MATTHEW SMITH
E1714
STATE OF NEBRASKA

**For Review Only
NOT FOR CONSTRUCTION**

C. 3

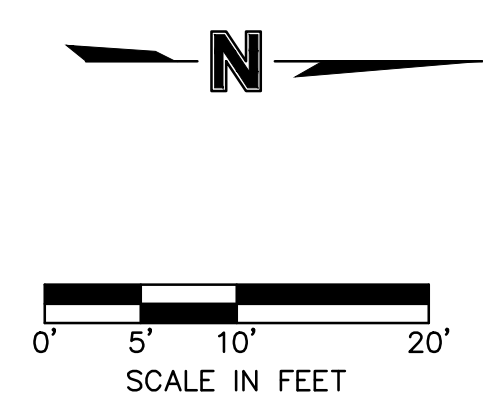
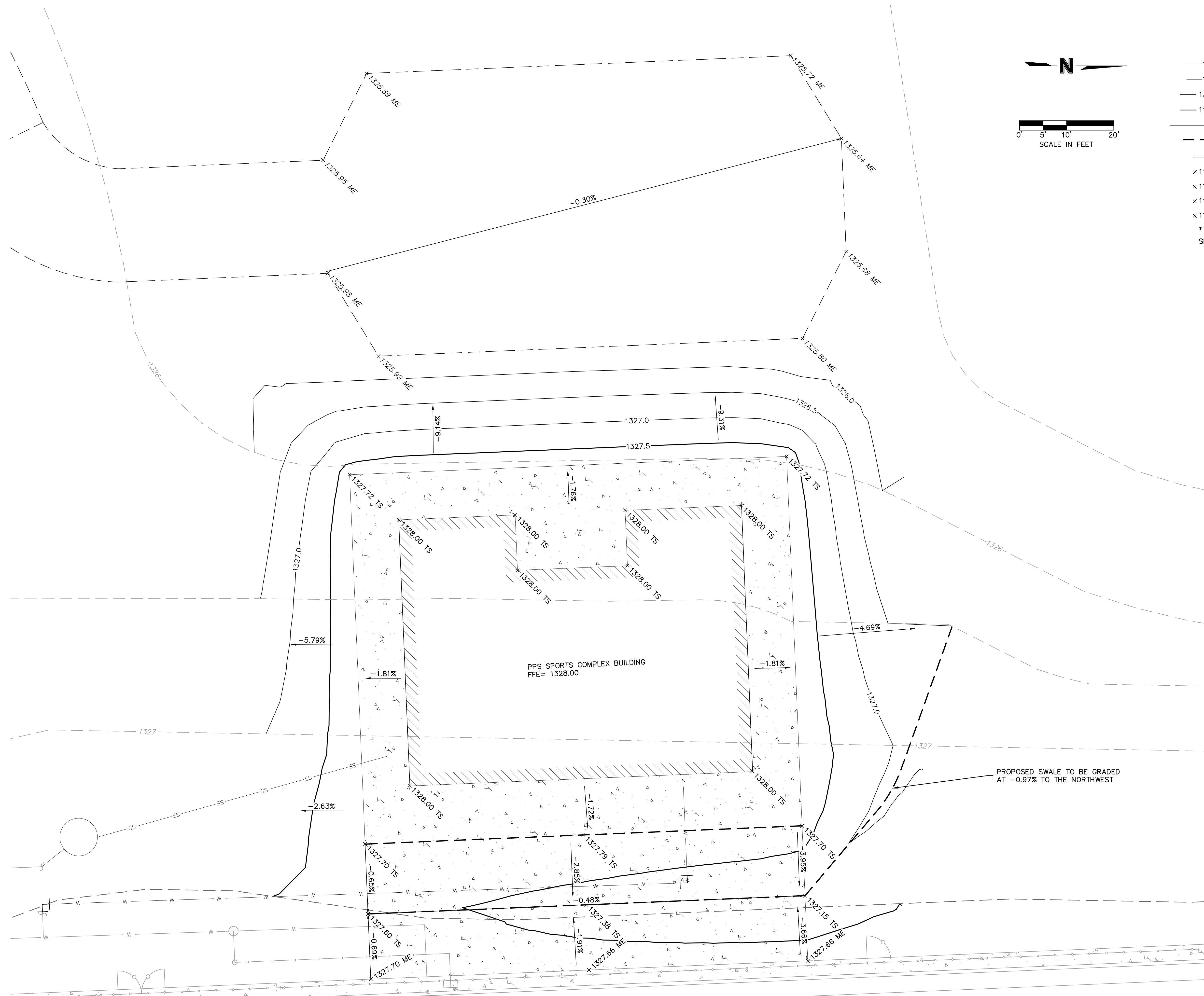

LEGEND

— 1300.00 —	EXISTING MAJOR CONTOUR
— 1300.50 —	EXISTING MINOR CONTOUR
— 1300.00 —	PROPOSED MAJOR CONTOUR
— 1130.50 —	PROPOSED MINOR CONTOUR
— LOD —	LIMITS OF DISTURBANCE
— — —	GRADE BREAK
— X.X % —	SLOPE
× 1130.50	SPOT ELEVATION
× 1130.50 ME	MATCH EXISTING ELEVATION
× 1130.50 TS	TOP OF SLAB ELEVATION
× 1130.50 TC	TOP OF CURB ELEVATION
*THE CONTOUR LINES AND SPOT ELEVATIONS SHOWN ARE TO FINISH GRADE FOR SURFACE.	

REVISIONS
AUGUST 1, 2023
PROJECT #: 23-04

GRADING PLAN

**PENDER PUBLIC SCHOOLS
SPORTS COMPLEX BUILDING**
PENDER, NEBRASKA

**PETERS & ASSOCIATES
ARCHITECTS, P.C.**
1103 GALVIN ROAD SOUTH, SUITE E
BELLEVUE, NEBRASKA 68005
PHONE: 402-885-8282

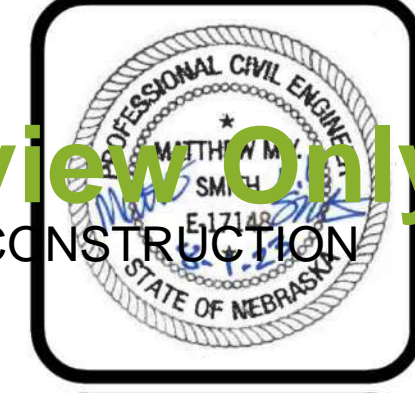

For Review Only
NOT FOR CONSTRUCTION

olsson

Engineering - Nebraska COA #CA-0638
1707 Dakota Avenue
South Sioux City, NE 68776-2356 TEL 402.494.3059 www.olsson.com

COPYRIGHT 2023
PETERS AND ASSOCIATES ARCHITECTS P.C. THESE DOCUMENTS ARE ISSUED BY PETERS AND ASSOCIATES ARCHITECTS P.C. AND ARE PROTECTED BY COPYRIGHT LAW. THEY MAY NOT BE REPRODUCED OR DUPLICATED IN WHOLE OR IN PART WITHOUT EXPRESS WRITTEN PERMISSION OF PETERS AND ASSOCIATES ARCHITECTS P.C., BELLEVUE, NE.

C. 4

LIFT STATION NOTES:

1. PROVIDE 1- BARNES PRESSURE SYSTEMS ULTRAGRIND JOBSITE WIRED BASIN PACKAGE OR APPROVED EQUAL. TO INCLUDE: 48" FIBERGLASS BASIN (9' DEEP), ESPS-200 LEVEL CONTROL, ALUMINUM COVER, 2- 2 HP SGV GRINDER PUMPS, 8" INLET HUB, STAINLESS STEEL LIFT CHAINS, STAINLESS STEEL GUIDE RAILS, JUNCTION BOXES, ELECTRICAL POWER CORDS, BALL VALVES, VALVE EXTENSION HANDLES, STAINLESS STEEL HARDWARE, PUMP BRACKETS, ANTI-SIPHON CHECK VALVES, CONTROL PANEL, CONTROL PANEL MOUNTING STRUTS AND HARDWARE, ALARMS, START-UP, OWNER TRAINING, O&W MANUALS, WARRANTY, AND ALL NECESSARY APPURTENANCES FOR A COMPLETE, FUNCTIONING WASTEWATER LIFT STATION.
2. CONTRACTOR TO VERIFY AND UTILIZE EXISTING ELECTRICAL SERVICE. COSTS ASSOCIATED WITH ELECTRICAL SERVICE OF THIS LIFT STATION SHALL BE CONSIDERED SUBSIDIARY TO THE PROJECT.

UTILITY NOTES:

1. CONTRACTOR SHALL FIELD VERIFY ALL EXISTING UTILITIES AT PROPOSED POINTS OF CONNECTION AND CONFIRM EXACT LOCATIONS/SIZES/MATERIALS OF ALL UTILITY SERVICE LINE HOOKUPS TO THE BUILDING (PER MEP PLANS) PRIOR TO UTILITIES CONSTRUCTION.
2. THE CONTRACTOR SHALL BE RESPONSIBLE FOR ARRANGING ONSITE MEETINGS WITH THE CITY, GOVERNING AGENCIES, AND UTILITY OWNERS PRIOR TO THE START OF ANY CONSTRUCTION OR INSTALLATION OF UTILITIES.
3. THE CONTRACTOR SHALL CONSTRUCT ALL WATER AND SANITARY SEWER SERVICE LINES, AND CONNECTIONS IN ACCORDANCE WITH THE APPLICABLE STANDARDS AND SPECIFICATIONS OF THE CITY OR LOCAL UTILITY PROVIDER.
4. THE CONTRACTOR IS RESPONSIBLE FOR COORDINATING UTILITY SERVICE CONNECTIONS WITH THE APPROPRIATE UTILITY COMPANY/OWNER, AND TO OBTAIN ALL PERMITS AND PAY ALL FEES AS REQUIRED FOR SERVICE CONNECTIONS TO UTILITY MAINS.
5. ALL SANITARY AND WATER SERVICE CONSTRUCTION TO BE DONE UNDER A PLUMBER'S PERMIT, AND SHALL COMPLY WITH ALL APPLICABLE BUILDING CODES AND NDEE STANDARDS.
6. CONTRACTOR TO FIELD VERIFY SANITARY SERVICE SIZE AND ELEVATION. IF CONTRACTOR IS UNABLE TO OBTAIN SLOPE MINIMUM FOR SANITARY, THE ENGINEER SHALL BE NOTIFIED IMMEDIATELY. CONTRACTOR SHALL NOT EXCEED 10% SLOPE UNLESS PER PLAN OR APPROVED BY JURISDICTIONAL ENGINEER.
7. UTILITY TRENCHES AND STRUCTURE EXCAVATIONS ARE TO BE SLOPED OR BRACED AND SHEETED AS NECESSARY FOR THE SAFETY OF THE WORKMEN AND THE PROTECTION OF OTHER UTILITIES IN COMPLIANCE WITH ALL APPLICABLE LOCAL, STATE AND FEDERAL REQUIREMENTS.
8. UNLESS OTHERWISE NOTED, CONTRACTOR SHALL PROVIDE TRENCHING FOR ALL UTILITY SERVICE LINES.
9. CONTRACTOR TO SET AND ADJUST ALL PROPOSED UTILITY STRUCTURES, CLEANOUTS, VALVES, METER PITS, ETC. TO FINISH GRADE. EXISTING ITEMS AFFECTED BY THE WORK SHALL BE ADJUSTED AS REQUIRED TO MATCH FINISH GRADE.
10. PRIOR TO FINAL ACCEPTANCE ALL WATER MAIN PIPE SHALL BE FLUSHED, PRESSURE TESTED AND DISINFECTED BY THE CONTRACTOR IN ACCORDANCE WITH NDEE STANDARDS.
11. THE CONTRACTOR WILL ASSIST THE CITY IN THE COMPLETION OF THE HYDROSTATIC PRESSURE AND LEAKAGE TESTING. IN THE EVENT OF A TEST FAILURE, THE CONTRACTOR IS RESPONSIBLE TO LOCATE AND MAKE ANY AND ALL REPAIRS TO THE WATER LINE TO ACHIEVE AN ACCEPTABLE TEST RESULT.
12. THE MINIMUM DEPTH FOR ALL WATER PIPE SHALL BE SIXTY (60) INCHES AS MEASURED FROM TOP OF PIPE TO FINISH GRADE.
13. ALL SANITARY SERVICE PIPE, AND FITTINGS SHALL BE PVC SDR 35.

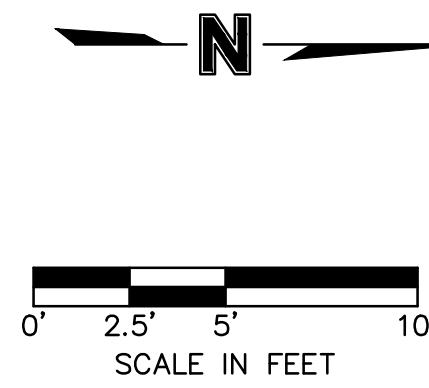

POINT TABLE			
POINT #	NORTHING	EASTING	FULL DESCRIPTION
1	848071.2594	2531307.5956	CONNECT TO WATER SERVICE - STUBOUT
2	848207.1391	2531280.6089	WATER SERVICE - BUILDING
3	848071.1293	2531297.5949	CONNECT TO SANITARY SERVICE - STUBOUT
4	848144.4127	2531274.1406	SANITARY SERVICE - BUILDING
5	848078.8951	2531291.3352	SANITARY LIFT STATION - CENTER
6	848208.0088	2531301.0192	90° BEND
7	848071.1757	2531305.5992	90° BEND

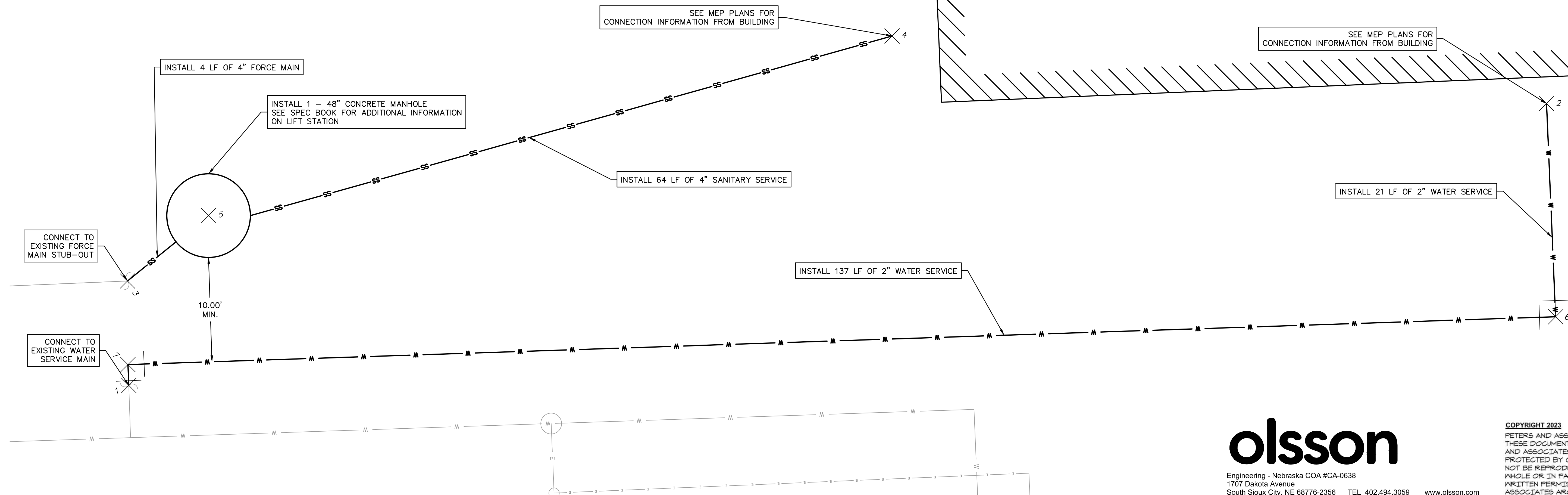
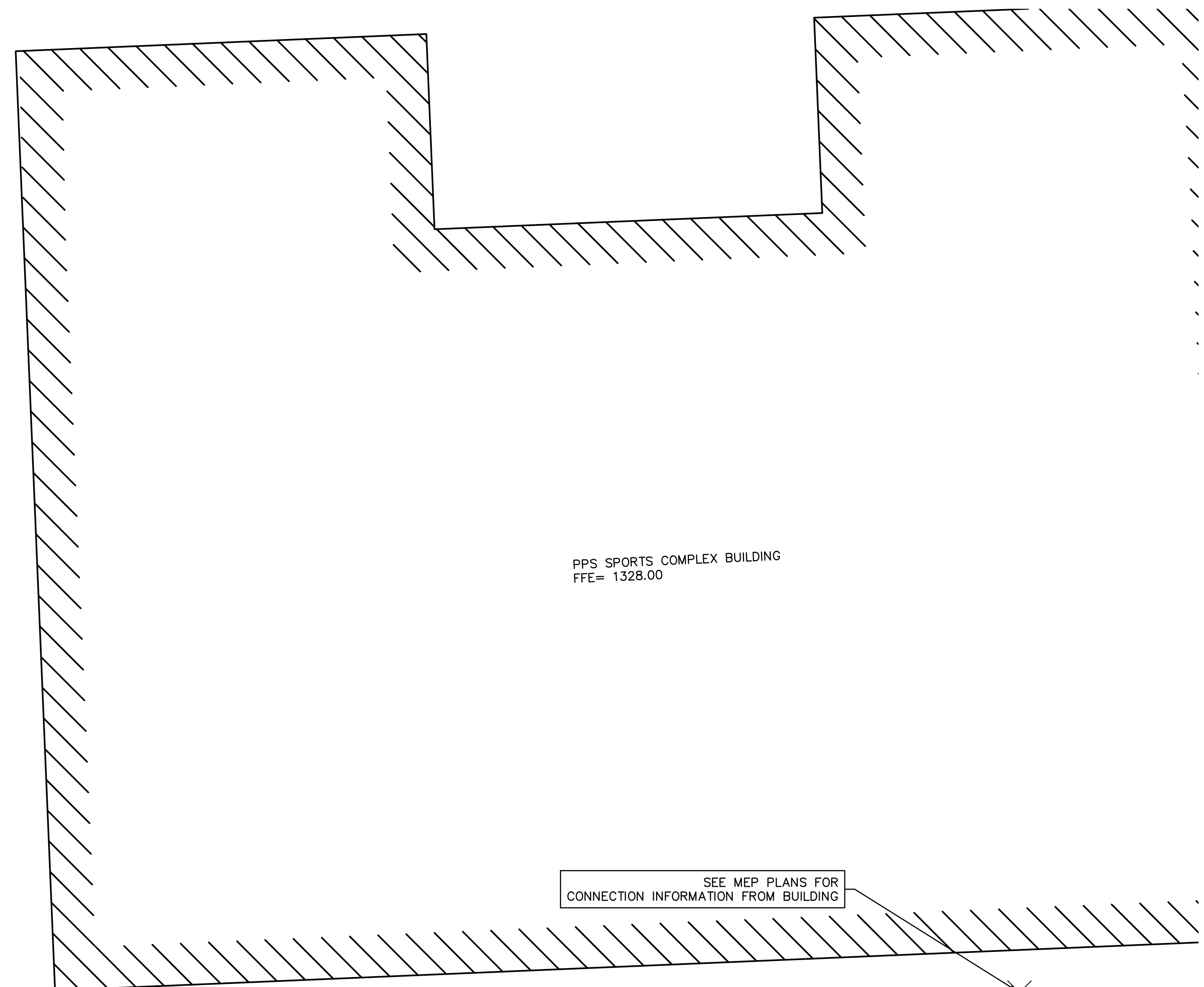

REVISIONS
AUGUST 1, 2023
PROJECT #: 23-04

UTILITIES PLAN

PENDER PUBLIC SCHOOLS
SPORTS COMPLEX BUILDING
PENDER, NEBRASKA

PETERS & ASSOCIATES
ARCHITECTS, P.C.
1103 GALVIN ROAD SOUTH,
BELLEVUE, NEBRASKA
PHONE: 402-885-8282

PROFESSIONAL CIVIL ENGINEER
MATTHEW M.Y. SMITH
E.I.T.
STATE OF NEBRASKA

For Review Only
NOT FOR CONSTRUCTION

olsson

Engineering - Nebraska COA #CA-0638
1707 Dakota Avenue
South Sioux City, NE 68776-2356 TEL 402.494.3059 www.olsson.com

COPYRIGHT 2023
PETERS AND ASSOCIATES ARCHITECTS P.C.
THESE DOCUMENTS ARE ISSUED BY PETERS
AND ASSOCIATES ARCHITECTS P.C. AND ARE
PROTECTED BY COPYRIGHT LAW. THEY MAY
NOT BE REPRODUCED OR DUPLICATED IN
WHOLE OR IN PART WITHOUT EXPRESS
WRITTEN PERMISSION OF PETERS AND
ASSOCIATES ARCHITECTS P.C., BELLEVUE, NE.

C. 5

Code Legend

1 HR WALL

FE FIRE EXTINGUISHER

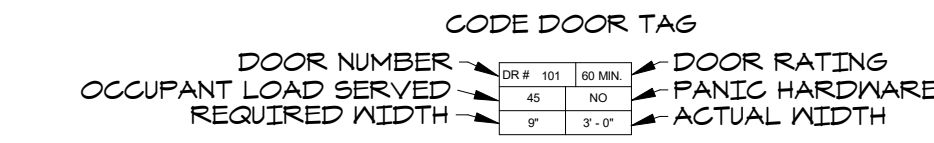
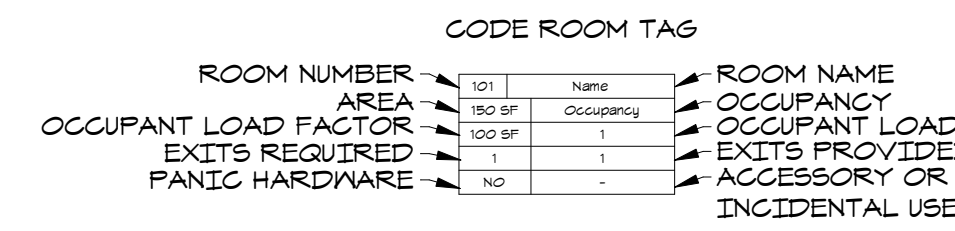

OCCUPANCY SCHEDULE

ROOM NO.	ROOM NAME	OCCUPANCY	AREA	OLF	OL	USE
101	Entry/ Circulation	A-5, ASSEMBLY	858 SF	5	112	
102	Home Locker Room	A-5, LOCKER RM	829 SF	50	13	
103	Men	A-5, ASSEMBLY	257 SF	50	6	ACCESSORY
104	Concessions	B-BUSINESS	230 SF	100	3	INCIDENTAL
105	Women	A-5, ASSEMBLY	268 SF	50	6	ACCESSORY
106	Mech	A-5, ASSEMBLY	65 SF	300	1	ACCESSORY
107	Shower	A-5, LOCKER RM	53 SF	50	2	ACCESSORY
108	Toilet	A-5, LOCKER RM	108 SF	50	3	ACCESSORY
109	Guest Locker Room	A-5, LOCKER RM	567 SF	50	12	
110	Entry Covered Patio	EXTERIOR	247 SF	0	0	ACCESSORY
111	Covered Patio	EXTERIOR	814 SF	0	0	ACCESSORY
112	Storage shed	A-5, STORAGE	281 SF	300	1	ACCESSORY
113	Electrical Room	A-5, MECHANICAL	281 SF	300	1	ACCESSORY
201	Bridge	A-5, UNCONCENTRATED	62 SF	15	4	ACCESSORY
202	Loft Space	A-5, UNCONCENTRATED	224 SF	15	16	
203	Outdoor Balcony	A-5, UNCONCENTRATED	344 SF	15	24	
Grand Total			5244 SF		264	

Building Codes

COMMERCIAL BUILDING CODE	2018 IBC - INTERNATIONAL BUILDING CODE
ELECTRICAL CODE	2017 NEC - NATIONAL ELECTRICAL CODE
ENERGY CODE	2018 IECC - INTERNATIONAL ENERGY CONSERVATION CODE
FIRE CODE	2012 LSC - LIFE SAFETY CODE AND 2018 IFC - INTERNATIONAL FIRE CODE
ACCESSIBILITY CODE	2018 IBC CH 11 - INTERNATIONAL BUILDING CODE (INCLUDING ICC/ANSI A117.1-2009)
MECHANICAL CODE	2018 IMC - INTERNATIONAL MECHANICAL CODE
PLUMBING CODE	UNIFORM PLUMBING CODE 2018

Building Design Statistics

TOTAL AREA	2 STORY BUILDING	FIRST FLOOR -	3,752 SF
		LOFT -	291 SF
		EXTERIOR BALCONY -	344 SF
CONSTRUCTION TYPES -	LIFE SAFETY CODE 2012 INTERNATIONAL BUILDING CODE	IV(000) HT NON-SPRINKLED	
OCCUPANCY CLASSIFICATION FOR USE OF BUILDING (BASED ON CHAPTER 3, IBC-2018/ LSC-2012)		A-3, ASSEMBLY / ASSEMBLY(12)	
ALLOWABLE SQUARE FOOT PER FLOOR AS PER IBC, TABLE 506.2		15,000 SF PER FLOOR	
OCCUPANT LOAD SHOWN ON SHEET A-1.1. SEE FLOOR PLANS AND SEE OCCUPANCY SCHEDULE.			
TRAVEL DISTANCE TO EXITS FOR AN ASSEMBLY (LSC-2012)	COMMON PATH OF TRAVEL	75 FEET (UNSPRINKLED)	
	DEAD-END LIMIT	20 FEET (UNSPRINKLED)	
	TRAVEL DISTANCE LIMIT	200 FEET (UNSPRINKLED)	
EXIT ACCESS TRAVEL DISTANCE (MAXIMUM ALLOWABLE) (IBC TABLE 1011.2)		200 FEET (UNSPRINKLED)	
MINIMUM CORRIDOR WIDTH (IBC TABLE 1020.2)		44 INCHES (MINIMUM)	
TOTAL OCCUPANT LOAD FOR EGRESS			
LOFT		44 OCCUPANTS	
MAIN LEVEL		220 OCCUPANTS	
TOTAL OCCUPANTS		264 OCCUPANTS	
NUMBER OF EXITS REQUIRED (IBC 1006 AND TABLE 1006.3.2)		2 EXITS REQUIRED	
NUMBER OF EXITS PROVIDED		6 EXITS PROVIDED	
EGRESS SIZING OTHER THAN STAIRS (0.2 INCHES PER OCCUPANT) (IBC 1009.3.2)		52.8 INCHES MIN. REQ'D	
EGRESS SIZING PROVIDED (4) 48" DOORS, (2) 36" DOORS		264 INCHES PROVIDED	
STAIR EGRESS SIZING (IBC 1011.2)		44 INCHES MIN. REQ'D	

Plumbing Fixture Count

PLUMBING DESIGN COUNT (NEW STADIUM BLEACHERS TO BE CONSTRUCTED IN A FUTURE PHASE, ESTIMATED TOTAL CAPACITY TO BE 400 OCCUPANTS.)

FIXTURES REQUIRED AS PER IBC 2018 - TABLE 2902.1

CLASSIFICATION	MALE	FEMALE	LAV	DF	SERVICE SINK
ASSEMBLY (STADIUM)	1 PER 75	1 PER 40	M - 1 PER 200 F - 1 PER 150	1 PER 1000	1 REQUIRED

FUTURE STADIUM/BLEACHERS ASSEMBLY 400 OCCUPANTS / 2 = 200 EACH SEX

REQUIRED FIXTURES	MALE	FEMALE	LAV	DF	SERVICE SINK
TOTAL REQUIRED	3	5	M-1, F-2	1	1

FIXTURES PROVIDED	MALE	FEMALE	LAV	DF	SERVICE SINK
PUBLIC	2 T, 2 U	5 T	M-2, F-2	1	1
GUEST LOCKER RM	1 T, 1 U				
HOME LOCKER RM	1 T, 1 U				

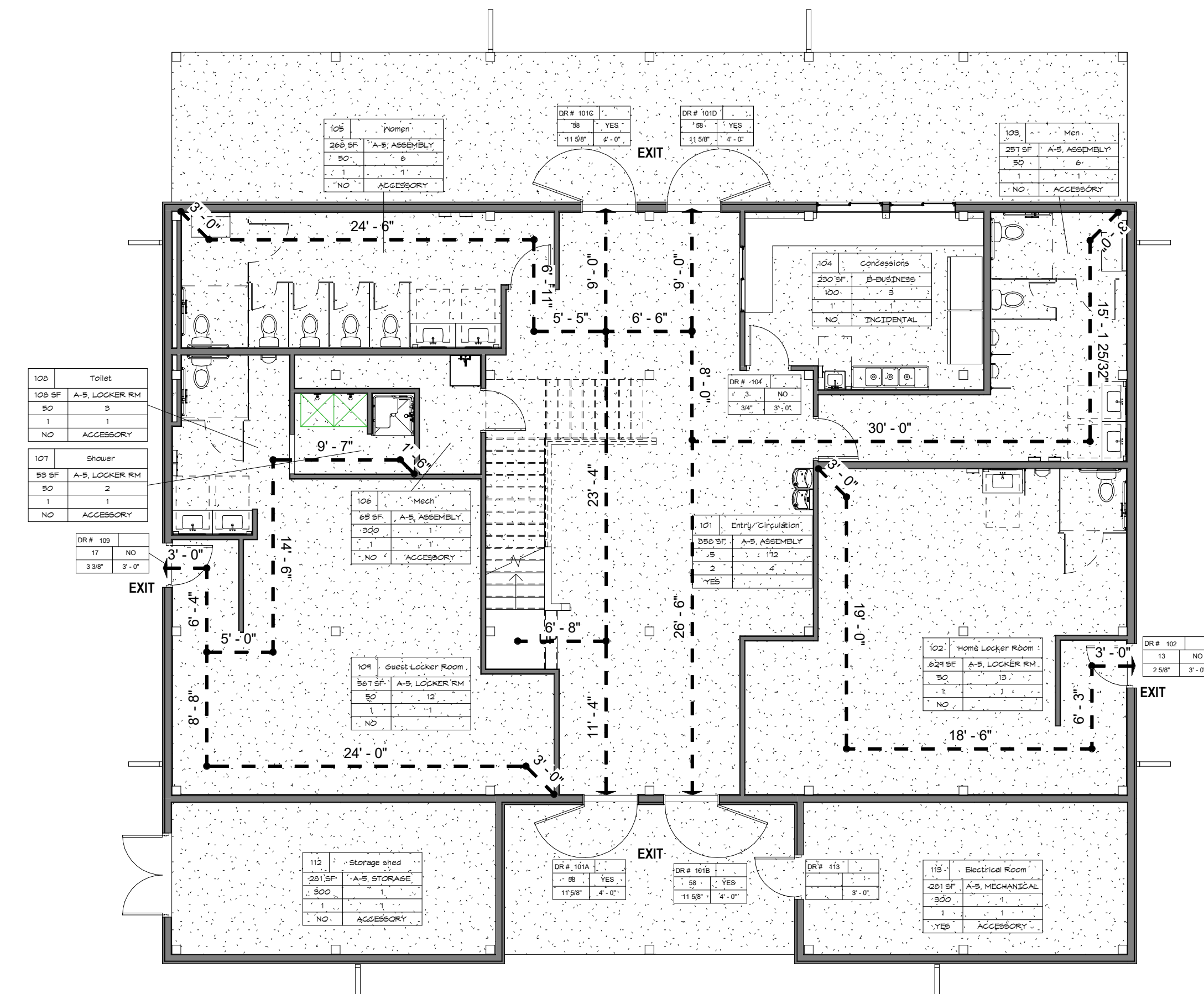
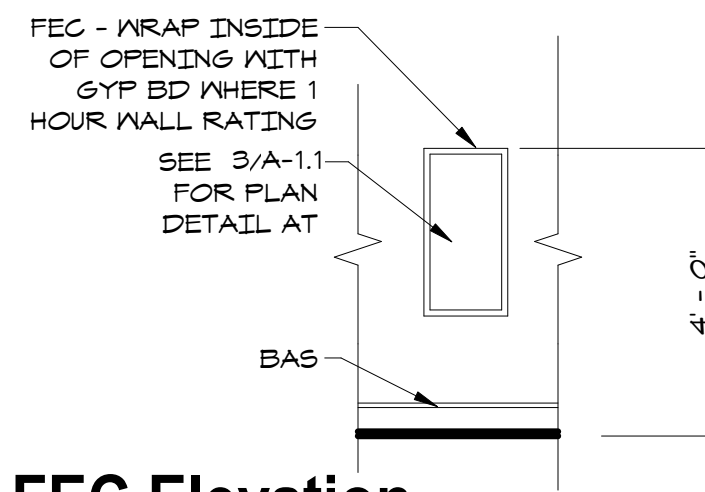
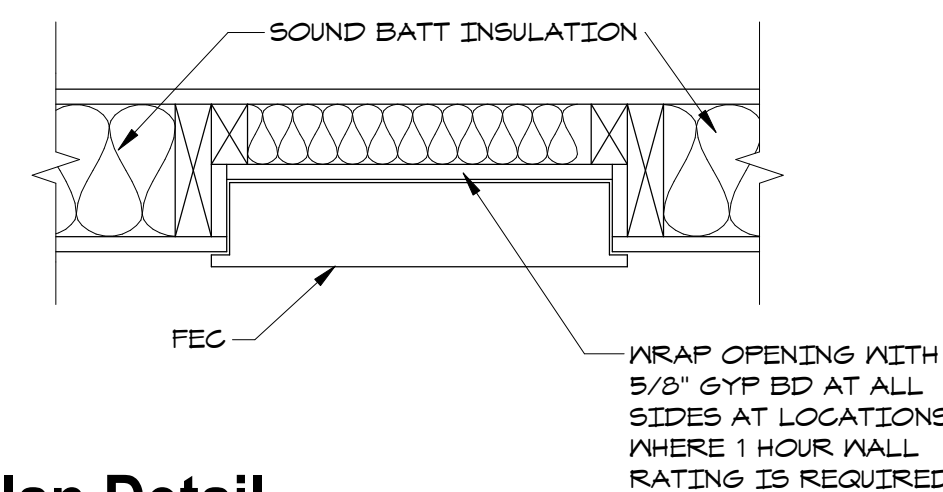

Code Plan - Loft

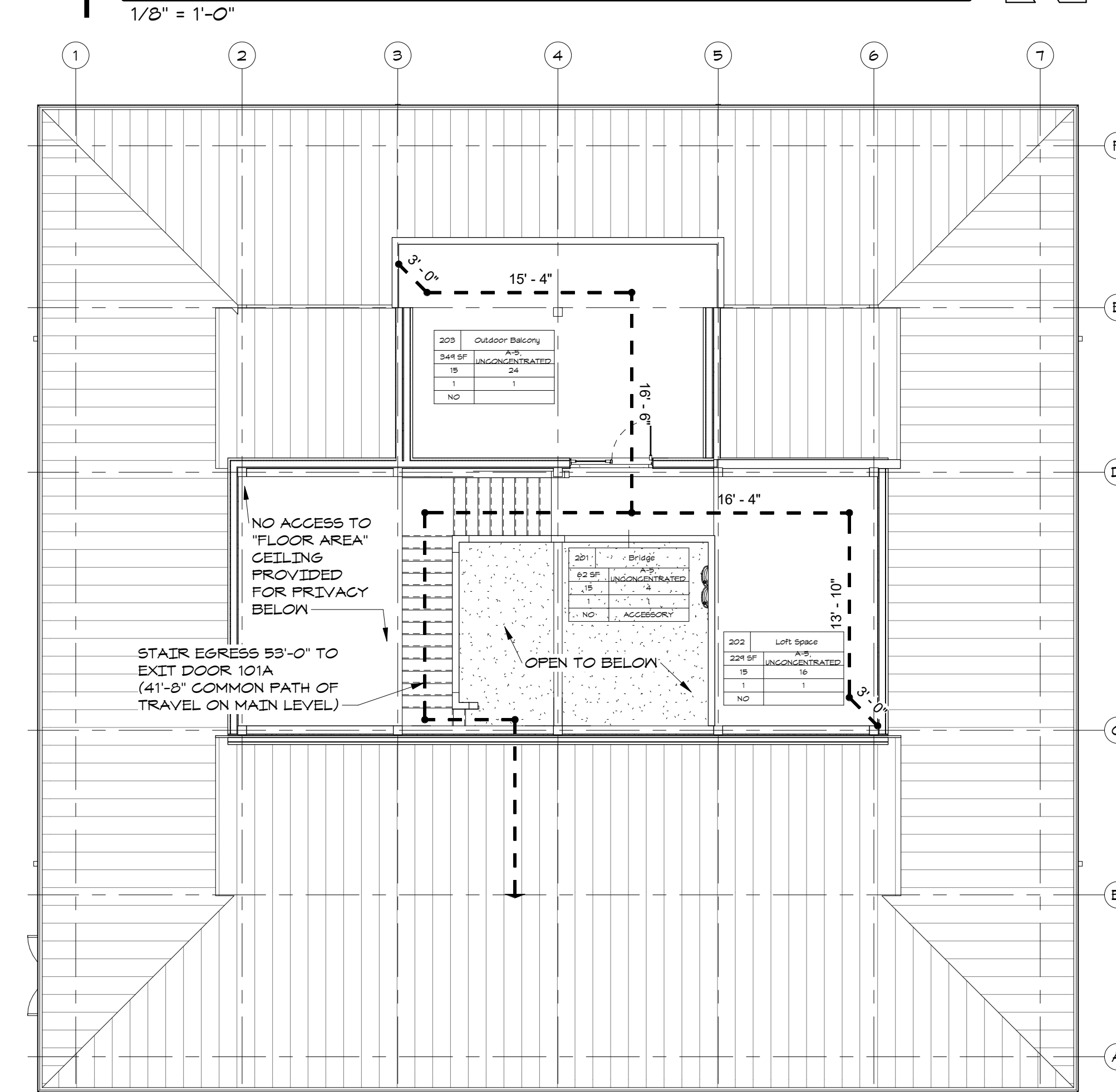

LOFT LEVEL NOTES:
LOFT WILL NOT BE OPEN TO PUBLIC. THE "LOFT SPACE 202" IS INTENDED TO BE USED TO STORE SOME EQUIPMENT OR POSSIBLY BE A LOCATION FOR REFERREES TO SIT DURING HALF TIME.

EXTERIOR BALCONY IS NOT FOR PUBLIC USE.

COPYRIGHT 2023
PETERS AND ASSOCIATES ARCHITECTS P.C.
THESE DOCUMENTS ARE ISSUED BY PETERS AND ASSOCIATES ARCHITECTS P.C. AND ARE PROTECTED BY COPYRIGHT LAW. THEY MAY NOT BE REPRODUCED OR DUPLICATED IN WHOLE OR IN PART WITHOUT EXPRESS WRITTEN PERMISSION OF PETERS AND ASSOCIATES ARCHITECTS P.C., BELLEVUE, NE.

REVISIONS
SEPTEMBER 15, 2023
PROJECT #: 23-01

CODE PLAN

PENDER PUBLIC SCHOOLS
SPORTS COMPLEX BUILDING
PENDER, NEBRASKA

PETERS & ASSOCIATES
ARCHITECTS, P.C.
1103 GALVYN ROAD SOUTH, SUITE E
BELLEVUE, NEBRASKA 68005
PHONE: 402-885-8882

FOR REVIEW ONLY
NOT FOR CONSTRUCTION

A-1.1

Architectural General Notes

1. CONTRACTOR SHALL VISIT THE SITE OF THE WORK PRIOR TO PREPARATION OF HIS BID IN ORDER TO BECOME FAMILIAR WITH EXISTING CONDITIONS AND THE GENERAL SCOPE OF THE WORK REQUIRED. DIMENSIONS ON THE PLAN ARE FROM FACE OF BRICK VENEER AT EXTERIOR WALL AND FROM FACE OF GYPSUM BOARD FINISH AT INTERIOR WALL PARTITIONS.
2. FINISH OF ALL GYPSUM BOARD AT WALLS AND SOFFITS SHALL BE SMOOTH FINISH TO RECEIVE PAINT. ALL GYPSUM BOARD CEILING SHALL BE BROOM OR BLOWN TEXTURE FINISH UNLESS OTHERWISE NOTED ON ROOM FINISH SCHEDULE.
3. CONTRACTOR SHALL VERIFY ALL EXISTING SITE CONDITIONS INCLUDING DIMENSIONS PRIOR TO THE START OF CONSTRUCTION.
4. CONTRACTOR SHALL NOTIFY ARCHITECT OF DISCREPANCIES BETWEEN DRAWINGS AND SPECIFICATIONS AND BETWEEN DRAWINGS, SPECIFICATIONS AND EXISTING CONDITIONS.
5. ALL GYPSUM WALL BOARD SHALL BE 5/8" FIRE CODE.
6. PROVIDE CONTROL JOINTS AT ALL CONCRETE FLOOR SLABS SUCH THAT JOINTS ARE NO GREATER THAN 10 FEET ON CENTER IN EITHER DIRECTION. FORM JOINTS BY SAW CUTTING 1/4 TIMES THE

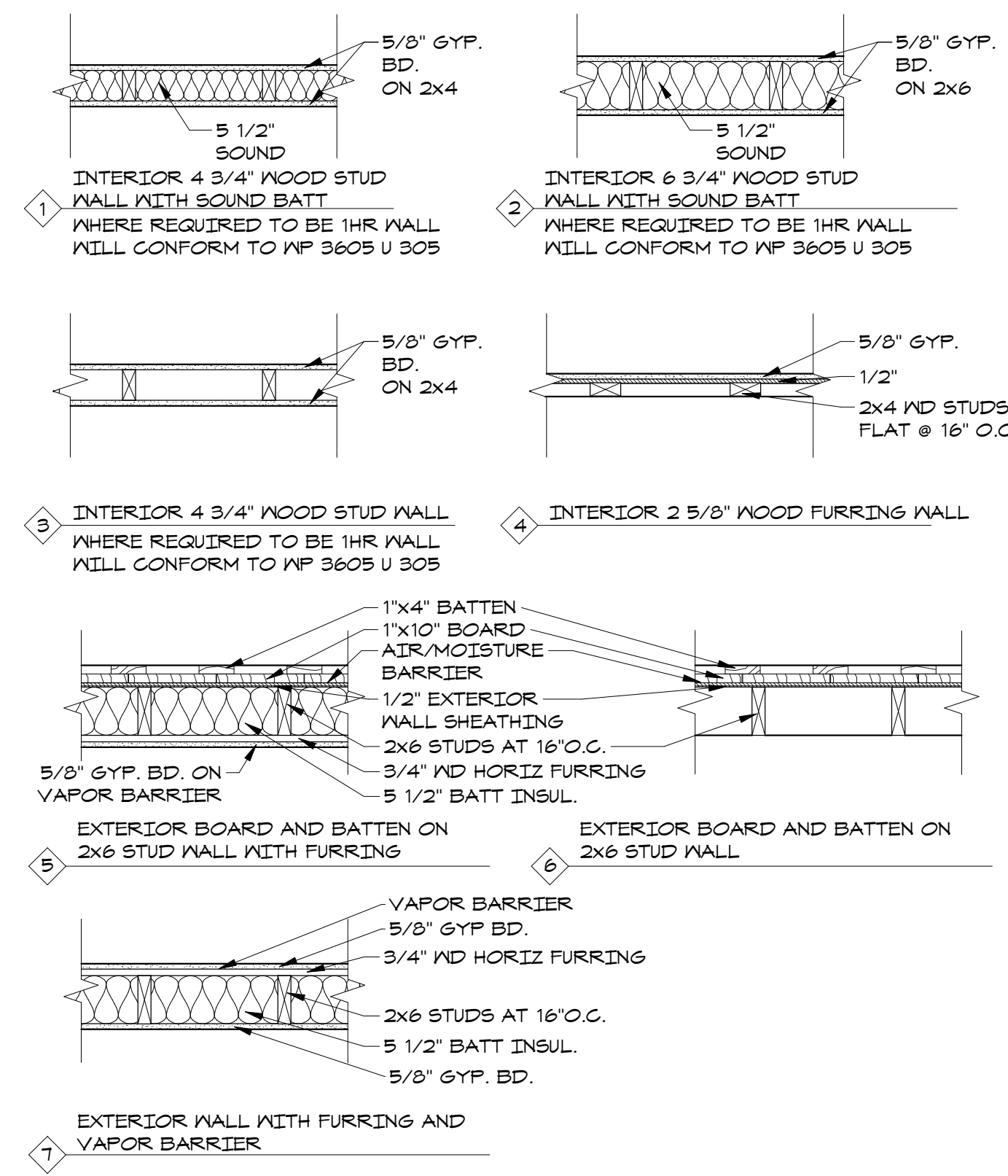

Wall Types

3/4" = 1'-0"

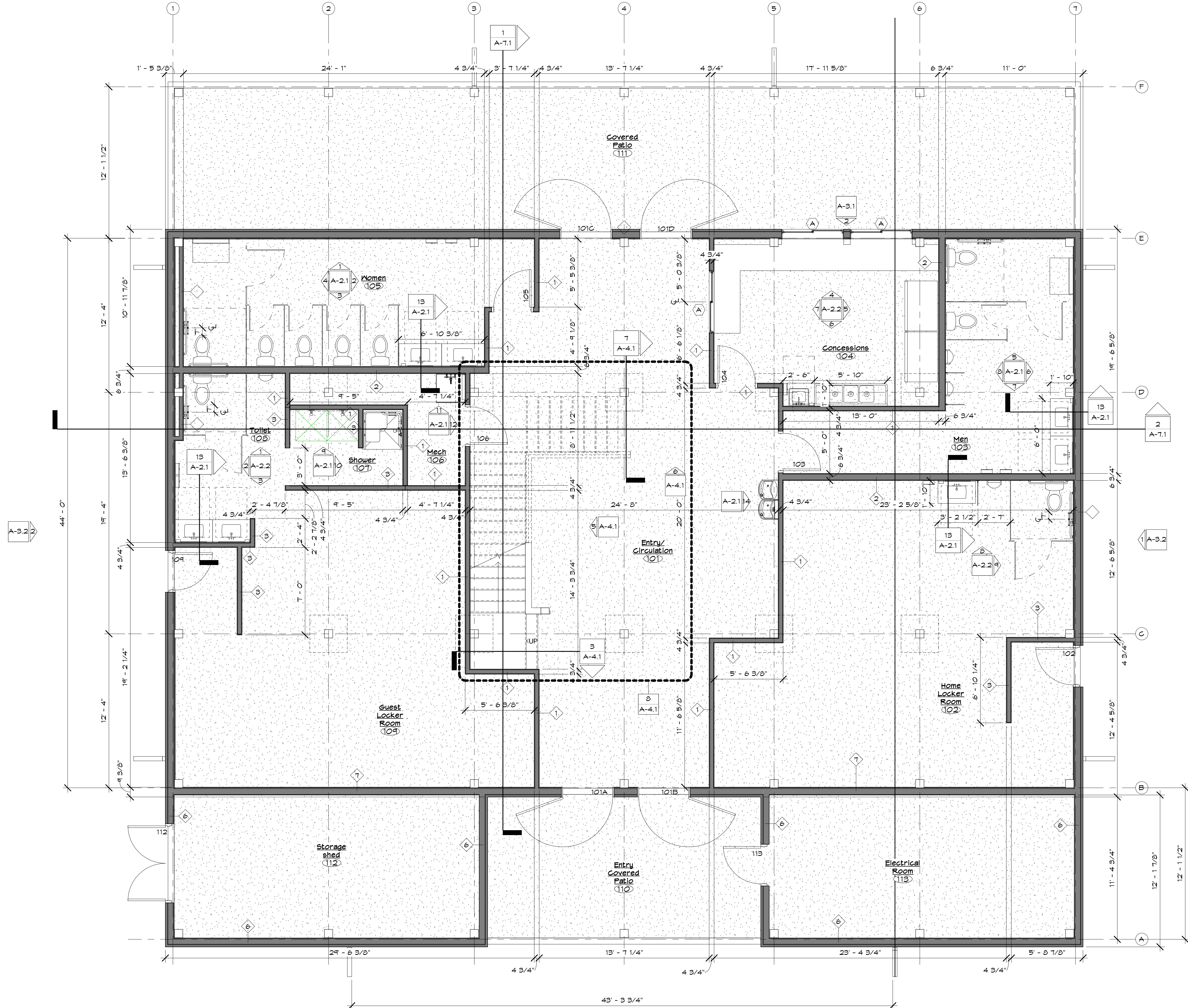

1 Floor Plan
 1/4" = 1'-0"

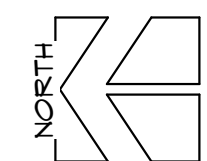

9/15/2023 1:04:10 AM BIM 360://23-01/PFS - Sports Complex Building/PFS-SportsComplex-Masterplan.rvt

COPYRIGHT 2023
 PETERS AND ASSOCIATES ARCHITECTS P.C.
 AND ASSOCIATES ARCHITECTS P.C. AND ARE
 PROTECTED BY COPYRIGHT LAW. THEY MAY
 NOT BE REPRODUCED OR DUPLICATED IN
 WHOLE OR IN PART WITHOUT EXPRESS
 WRITTEN PERMISSION OF PETERS AND
 ASSOCIATES ARCHITECTS P.C., BELLEVUE, NE.

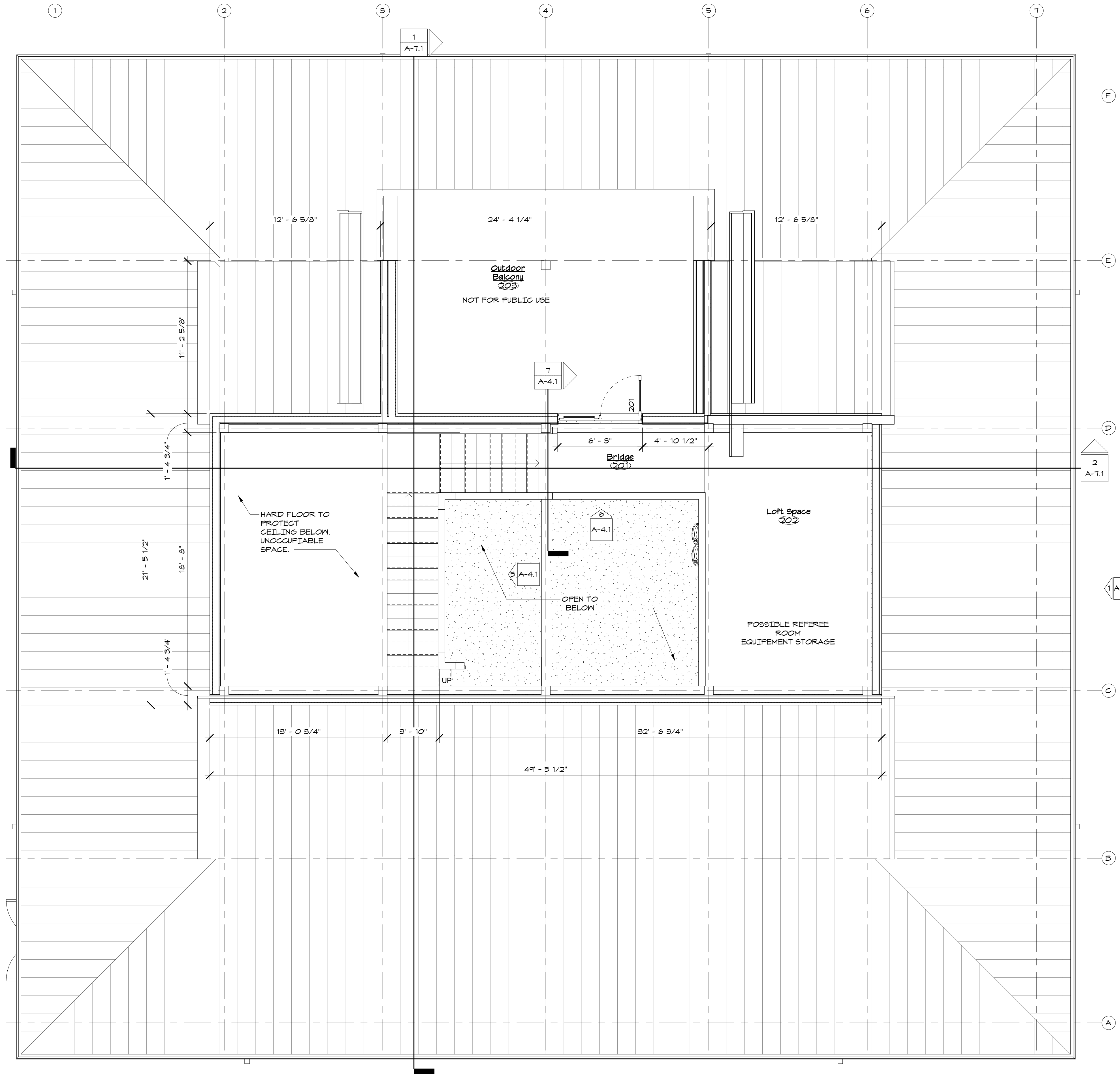

1 Loft Floor Plan
1/4" = 1'-0"

A-3.1

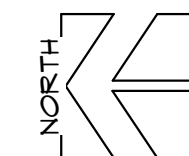

A-3.2.2

1A-3.2

2
A-7.1

REVISIONS	SEPTEMBER 15, 2023	PROJECT #: 23-04
-----------	--------------------	------------------

LOFT FLOOR PLAN

**PENDER PUBLIC SCHOOLS
SPORTS COMPLEX BUILDING
PENDER, NEBRASKA**

**PETERS & ASSOCIATES
ARCHITECTS, P.C.**
1103 GALVIN ROAD SOUTH, SUITE 6000
BELLEVUE, NEBRASKA 402-885-8828
PHONE: 402-885-8828

**FOR
REVIEW
ONLY**
NOT FOR
CONSTRUCTION

A-1.3

COPYRIGHT 2023
PETERS AND ASSOCIATES ARCHITECTS P.C.
THESE DOCUMENTS ARE ISSUED BY PETERS
AND ASSOCIATES ARCHITECTS P.C. AND ARE
PROTECTED BY COPYRIGHT LAW. THEY MAY
NOT BE REPRODUCED OR DUPLICATED IN
WHOLE OR IN PART WITHOUT EXPRESS
WRITTEN PERMISSION OF PETERS AND
ASSOCIATES ARCHITECTS P.C., BELLEVUE, NE.

9/15/2023 10:10 AM E:\300\23-04\PPS - Sports Complex Building\PPS-SportsComplex-Master.dwg

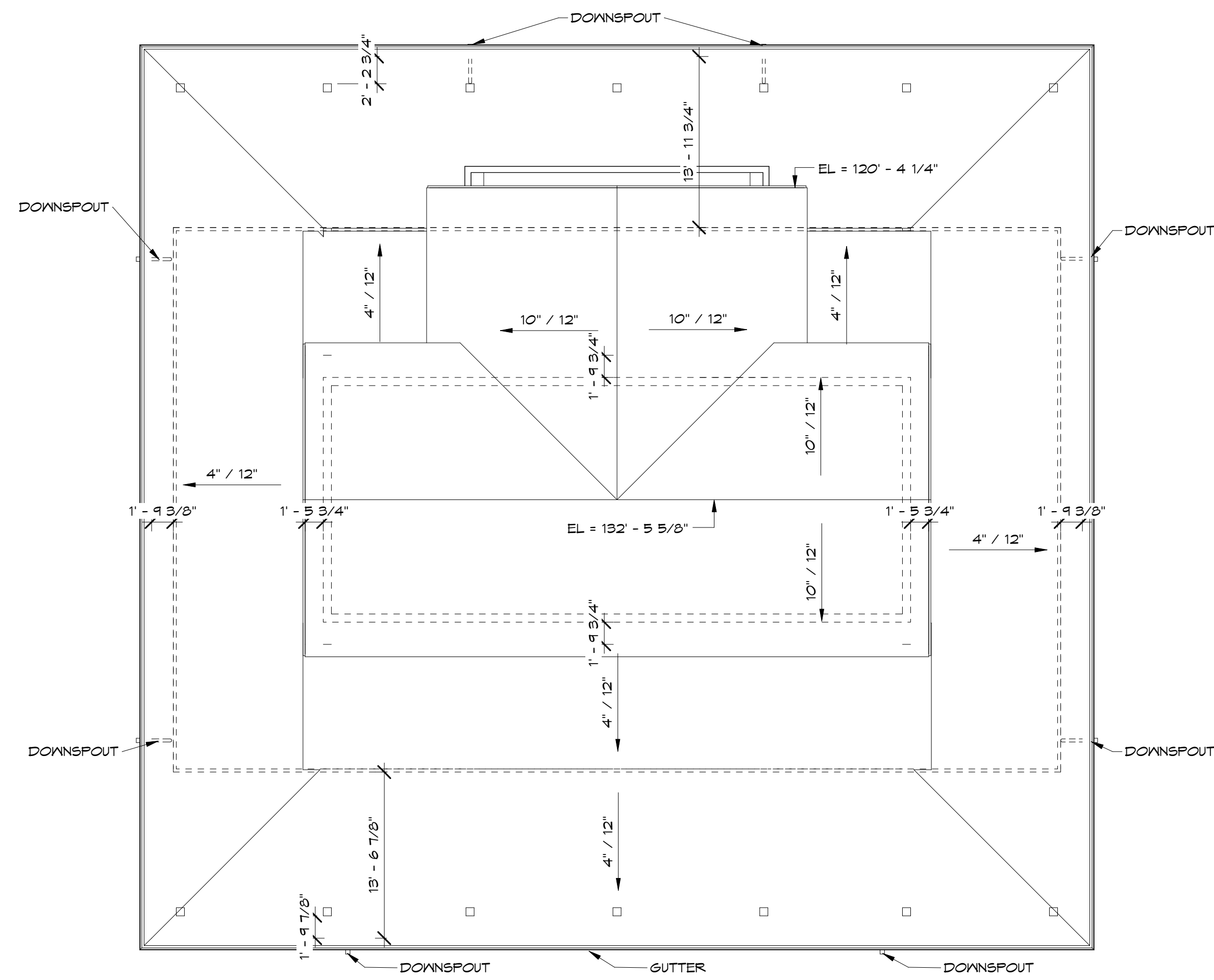

3 Roof Plan
1/8" = 1'-0"

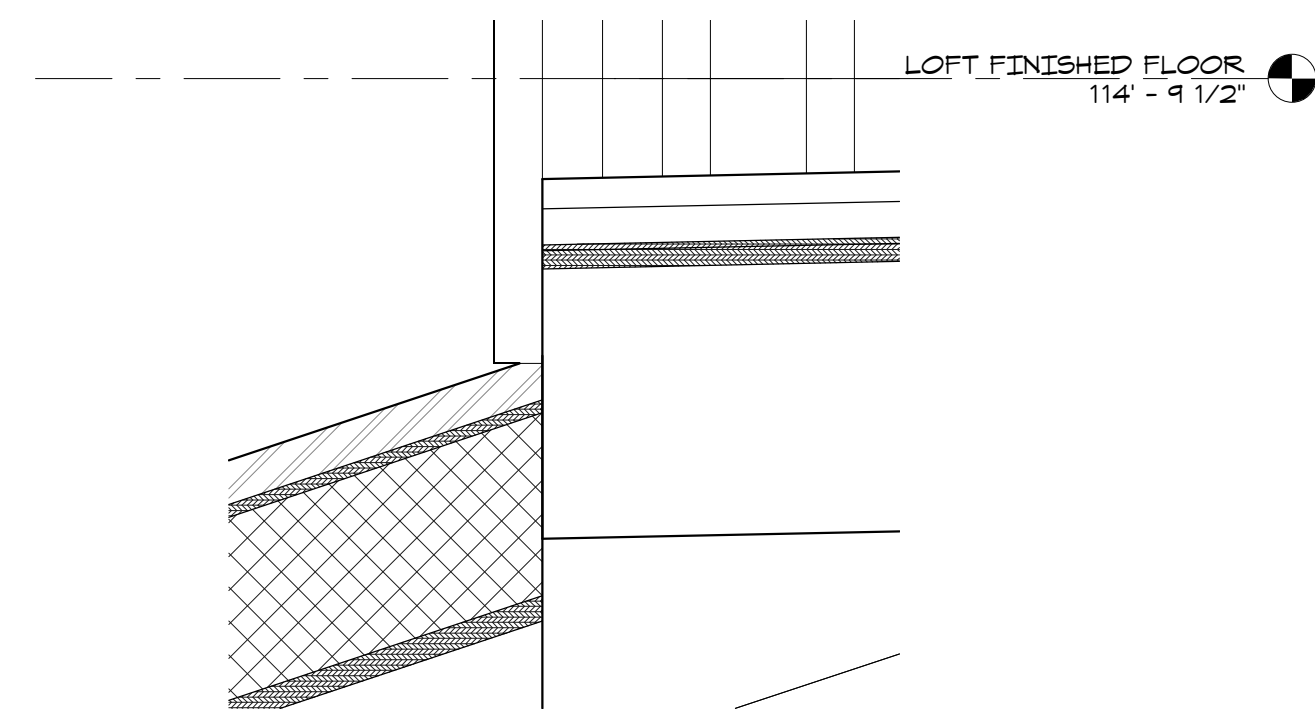

4 Outdoor Balcony Detail
1 1/2" = 1'-0"

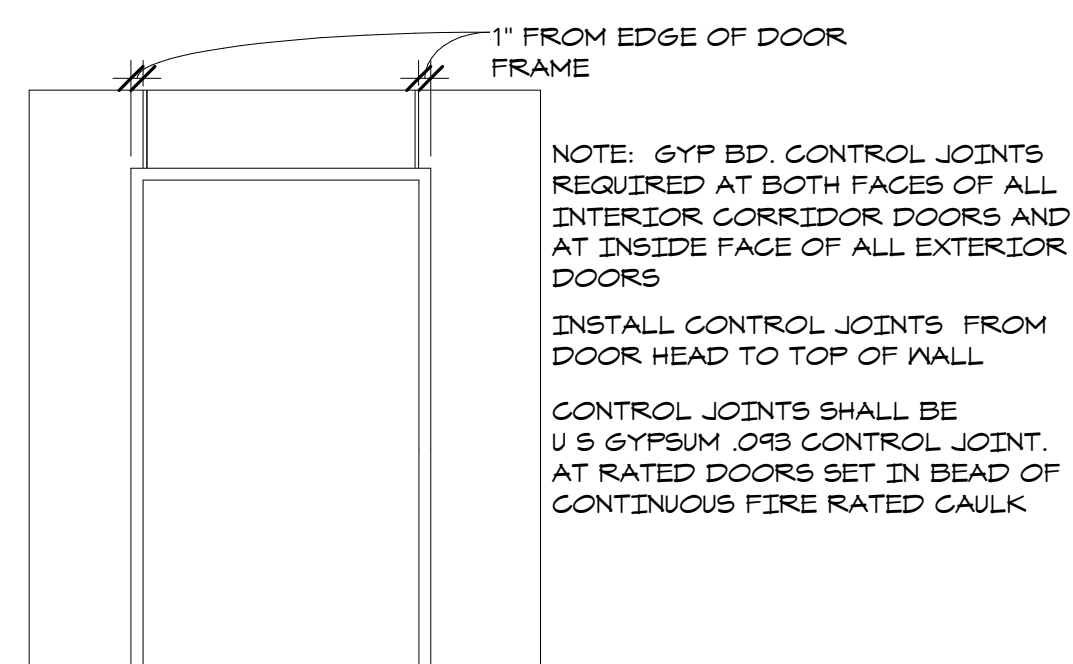

6 Gyp Control Joint Over Doors Detail
3/8" = 1'-0"

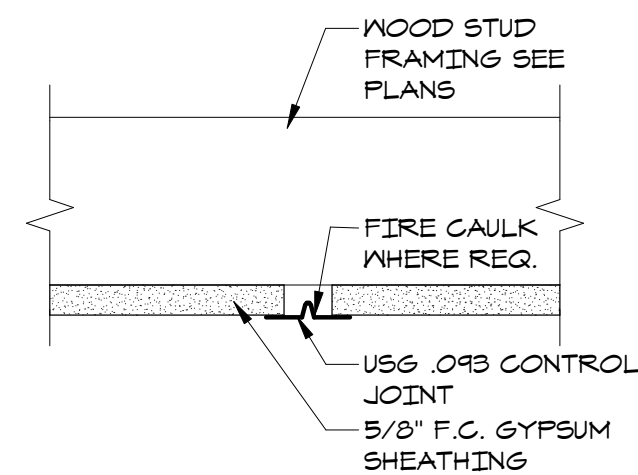

5 Gyp Control Joint Detail
3" = 1'-0"

DECK - EXTERIOR DECK BOARD
E-PNT - EPOXY PAINT
GYP - F.G. GYPSUM BOARD
PNT - PAINT
PLY - UNFINISHED PLYWOOD
SC - POLISHED CONCRETE
VIN - VINYL BASE

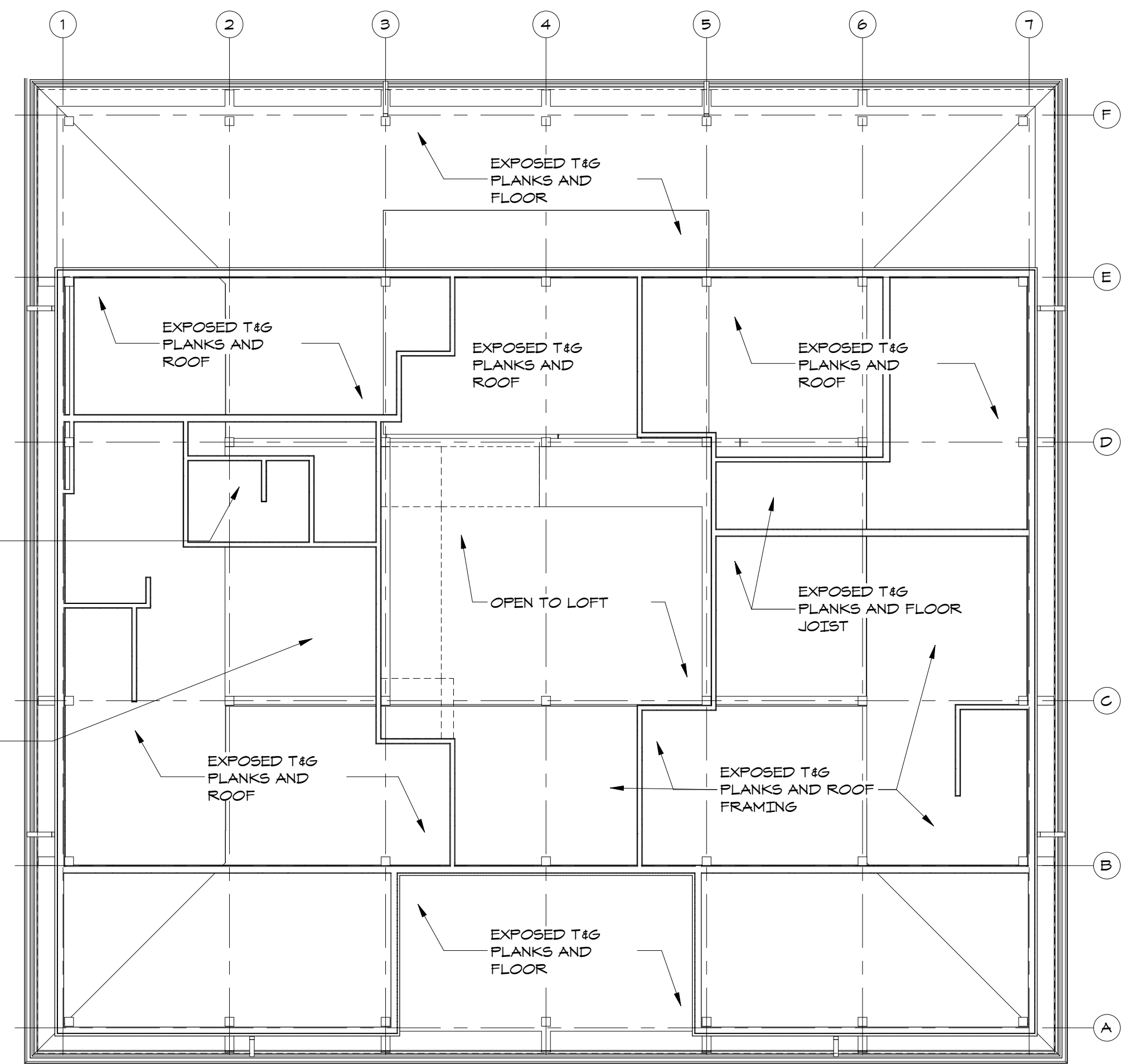

1 Main Level Reflected Ceiling Plan
1/8" = 1'-0"

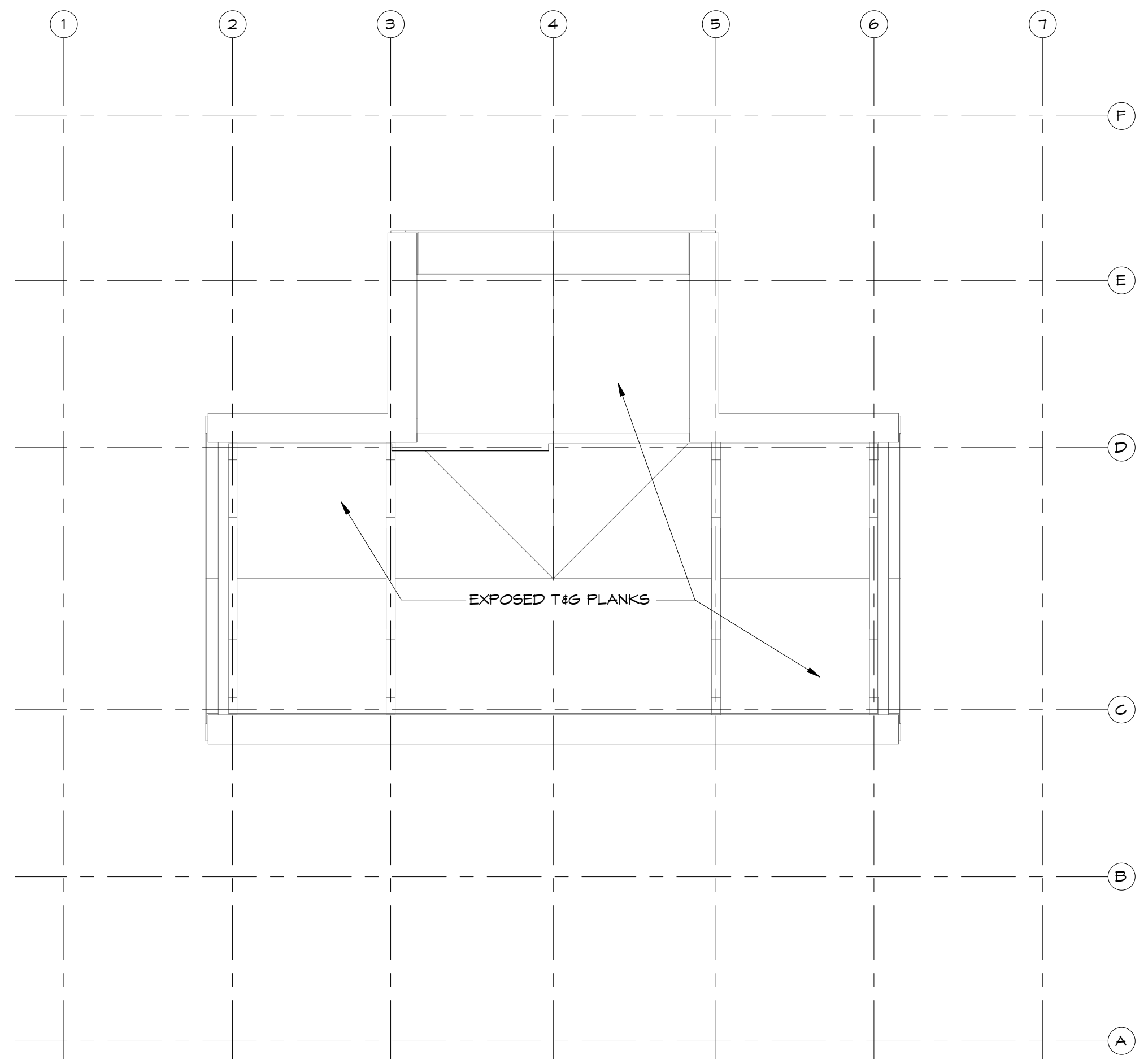

2 Loft Reflected Ceiling Plan
1/8" = 1'-0"

Room Finish Schedule

ROOM NO.	ROOM NAME	FLOOR	BASE	WALL				REMARKS
				NORTH	EAST	SOUTH	WEST	
101	Entry/ Circulation	SC	VIN	GYP/PNT	GYP/PNT	GYP/PNT	GYP/PNT	
102	Home Locker Room	SC	VIN	GYP/PNT	GYP/PNT	GYP/PNT	GYP/PNT	
103	Men	SC	VIN	GYP/E-PNT	GYP/E-PNT	GYP/E-PNT	GYP/E-PNT	
104	Concessions	SC	VIN	GYP/E-PNT	GYP/E-PNT	GYP/E-PNT	GYP/E-PNT	
105	Women	SC	VIN	GYP/E-PNT	GYP/E-PNT	GYP/E-PNT	GYP/E-PNT	
106	Mech	SC	VIN	GYP/PNT	GYP/PNT	GYP/PNT	GYP/PNT	
107	Shower	SC	VIN	GYP/E-PNT	GYP/E-PNT	GYP/E-PNT	GYP/E-PNT	
108	Toilet	SC	VIN	GYP/E-PNT	GYP/E-PNT	GYP/E-PNT	GYP/E-PNT	
109	Guest Locker Room	SC	VIN	GYP/E-PNT	GYP/E-PNT	GYP/E-PNT	GYP/E-PNT	
110	Entry Covered Patio	CONC		GYP/PNT				
111	Covered Patio	CONC		GYP/PNT				
112	Storage shed	CONC						
113	Electrical Room							FLOOR TO BE POURED AT A LATER TIME
201	Bridge	PLY	VIN	GYP/PNT				
202	Loft Space	PLY	VIN	GYP/PNT	GYP/PNT	GYP/PNT		
203	Outdoor Balcony	DECK						DECKING OVER EPDM ROOFING

REVISIONS
SEPTEMBER 15, 2023
PROJECT #: 23-01

REFLECTED CEILING PLANS AND
ROOF PLAN, ROOM FINISH SCHEDULE
AND DETAILS

PENDER PUBLIC SCHOOLS
SPORTS COMPLEX BUILDING
PENDER, NEBRASKA

PETERS & ASSOCIATES
ARCHITECTS, P.C. SUITE E 6000S
1103 GALVIN ROAD SOUTH, BELLEVUE, NEBRASKA 402-885-8582
PHONE: 402-885-8582

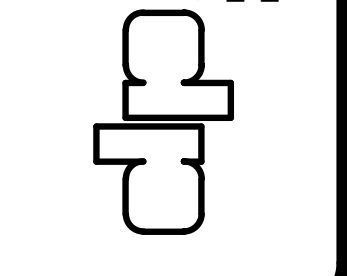

FOR
REVIEW
ONLY
NOT FOR
CONSTRUCTION

A-1.4

COPYRIGHT 2023
PETERS AND ASSOCIATES ARCHITECTS P.C.
THESE DOCUMENTS ARE ISSUED BY PETERS
AND ASSOCIATES ARCHITECTS P.C. AND ARE
PROTECTED BY COPYRIGHT LAW. THEY MAY
NOT BE REPRODUCED OR DUPLICATED IN
WHOLE OR IN PART WITHOUT EXPRESS
WRITTEN PERMISSION OF PETERS AND
ASSOCIATES ARCHITECTS P.C., BELLEVUE, NE.

ITEM	DESCRIPTION	MFR	MODEL NO	RECESSED	SEMI-RECESSED	SURFACE MTD	MOUNTING HEIGHT
TA-1	GRAB BAR 42"	BOBRICK	6806 X42			X	33"-36" A.F.F. TO CENTERLINE
TA-2	GRAB BAR 36"	BOBRICK	6806 X36			X	33"-36" A.F.F. TO CENTERLINE
TA-3	VERTICAL GRAB BAR 18"	BOBRICK	6806 X18			X	SEE INTERIORS
TA-4	TOILET PAPER DISPENSER	BOBRICK	B-2140			X	SEE INTERIORS
TA-5	MIRROR 24" X 36"	BOBRICK	B-165 2436			X	40" TO REFLECTIVE SURFACE
TA-6	PAPER TOWEL DISPENSER	BOBRICK	B-262			X	SEE INTERIORS
TA-7	SOAP DISPENSER	BOBRICK	B-2111			X	SEE INTERIORS
TA-8	BABY CHANGING STATION	BOBRICK	KB200-00			X	SEE INTERIORS
TA-9	MOP AND BROOM HOLDER	BOBRICK	B-223			X	SEE INTERIORS

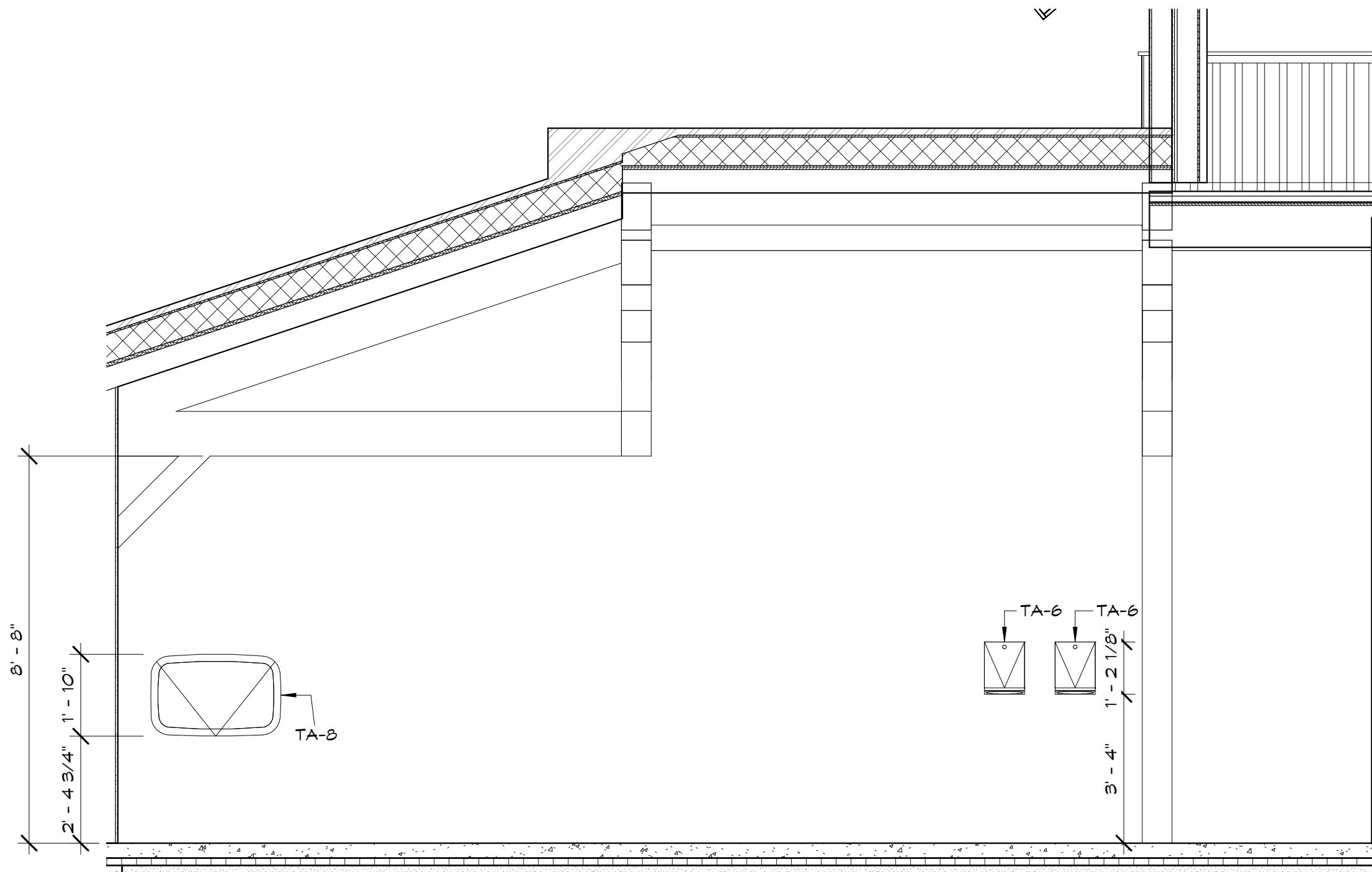

1 Women 105 - A
3/8" = 1'-0"

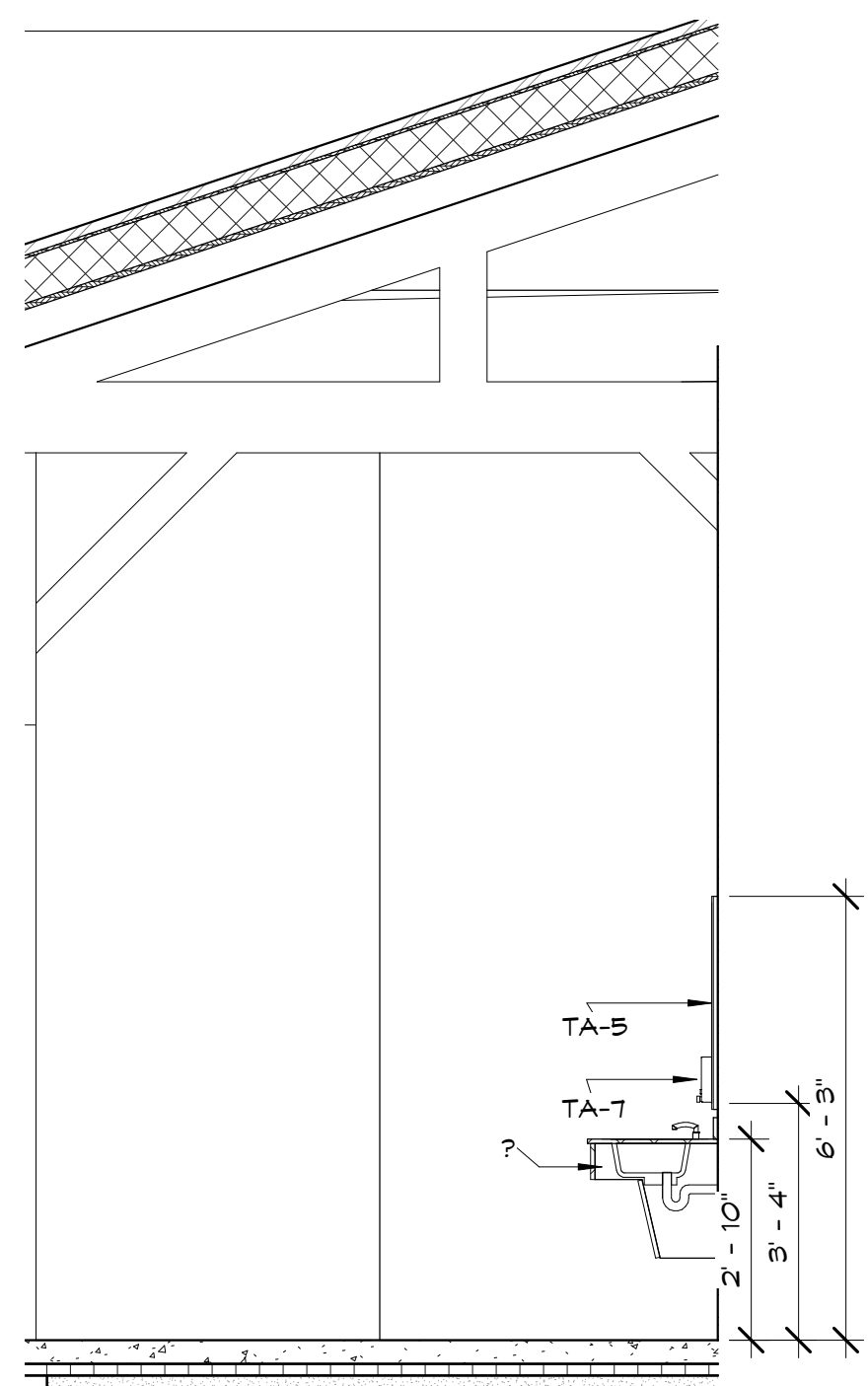

2 Women 105 - B
3/8" = 1'-0"

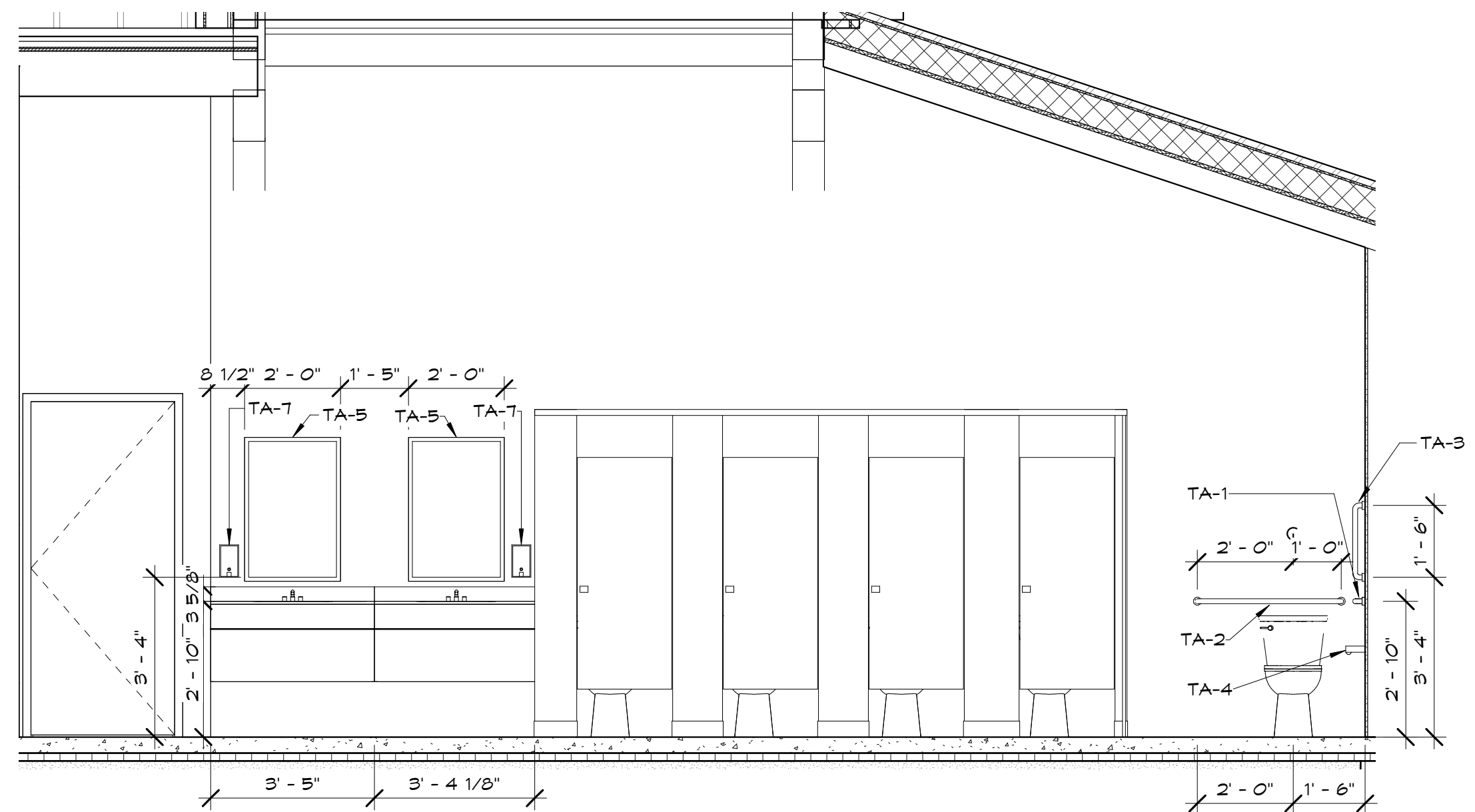

3 Women 105 - C
3/8" = 1'-0"

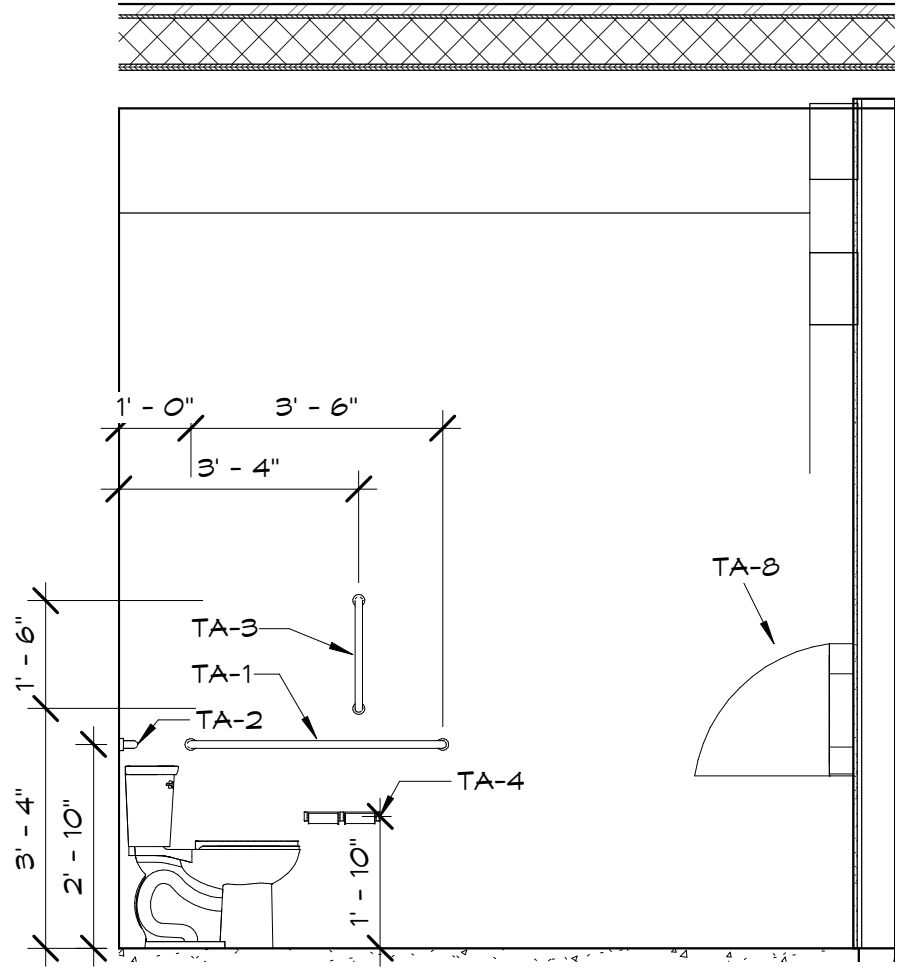

4 Women 105 - D
3/8" = 1'-0"

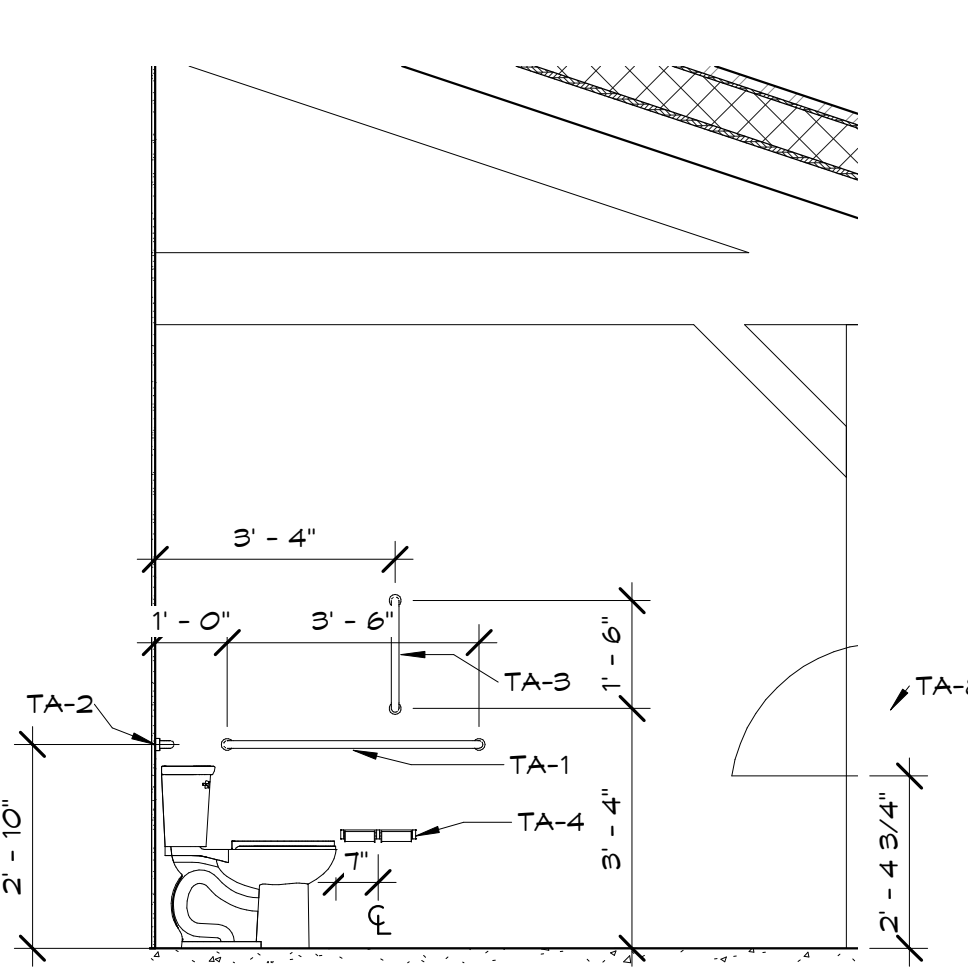

5 Men 103 - A
3/8" = 1'-0"

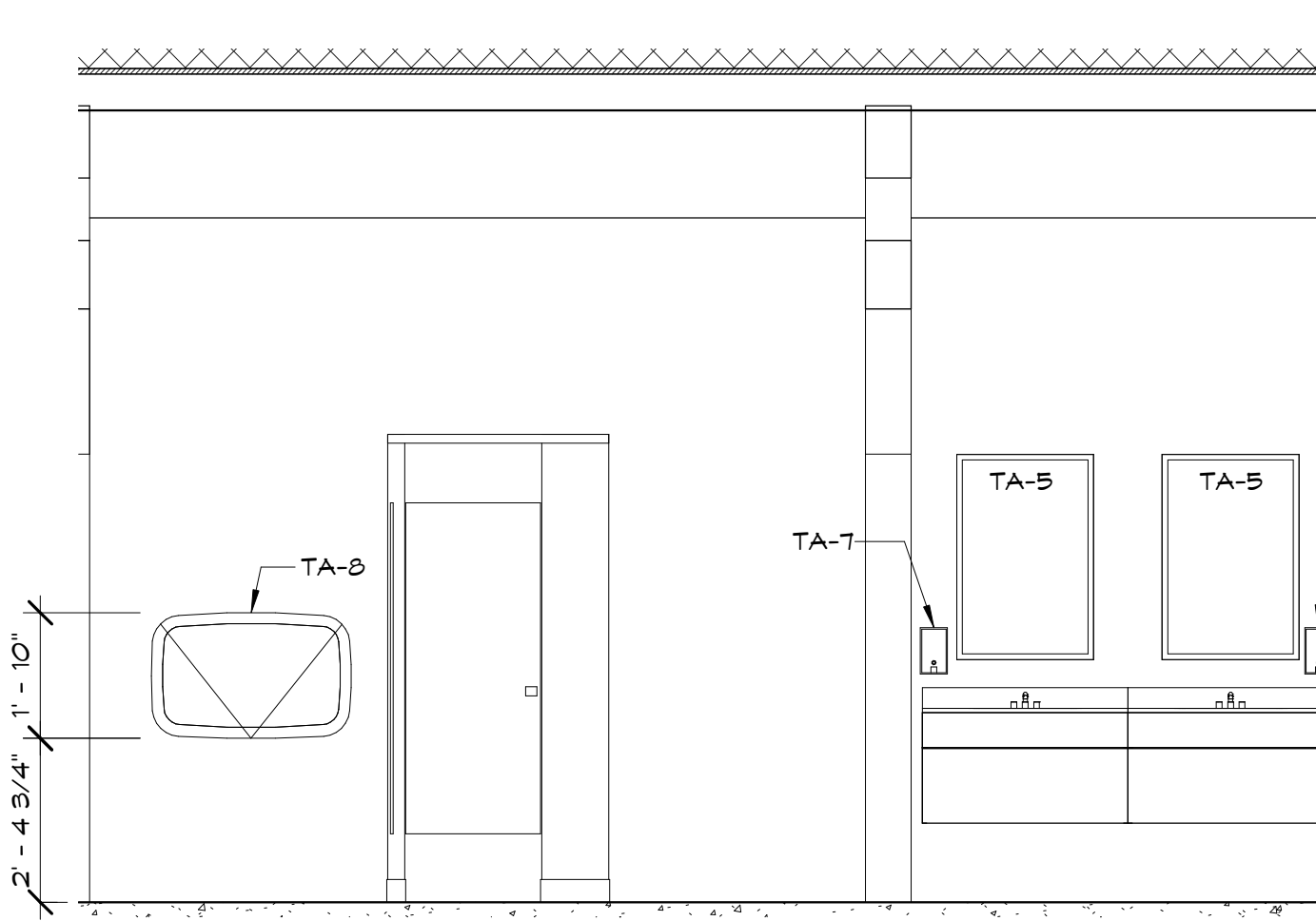

6 Men 103 - B
3/8" = 1'-0"

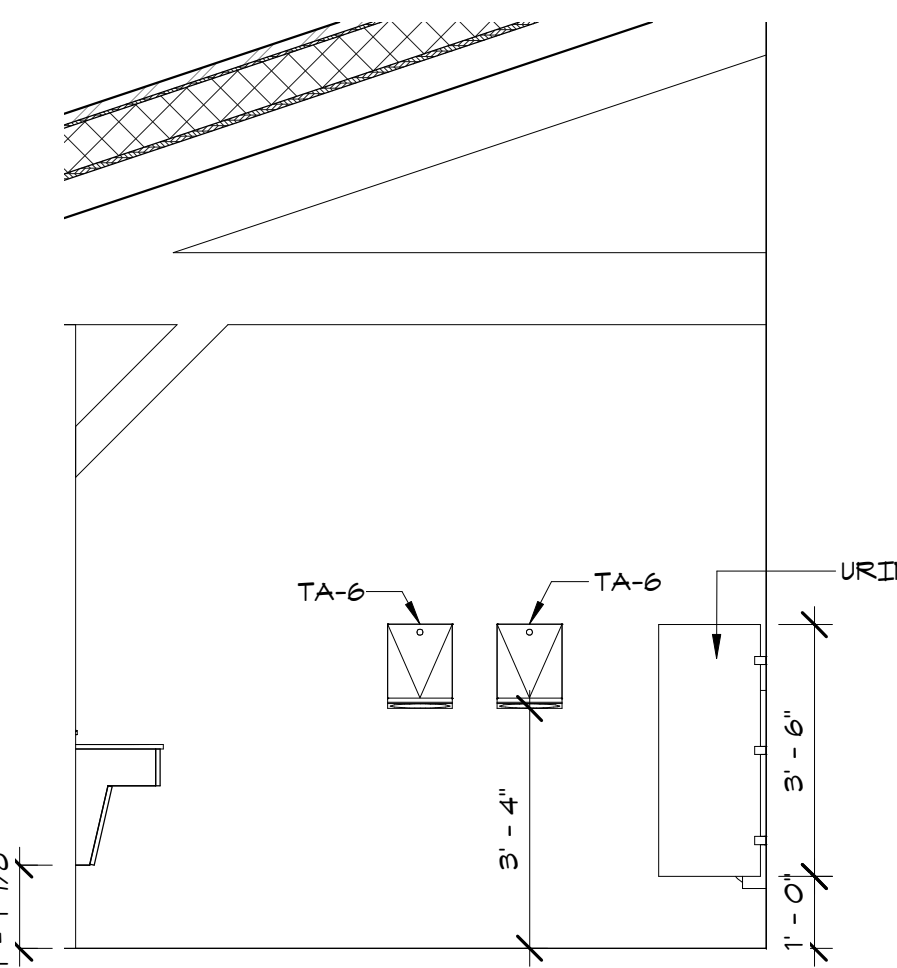

7 Men 103 - C
3/8" = 1'-0"

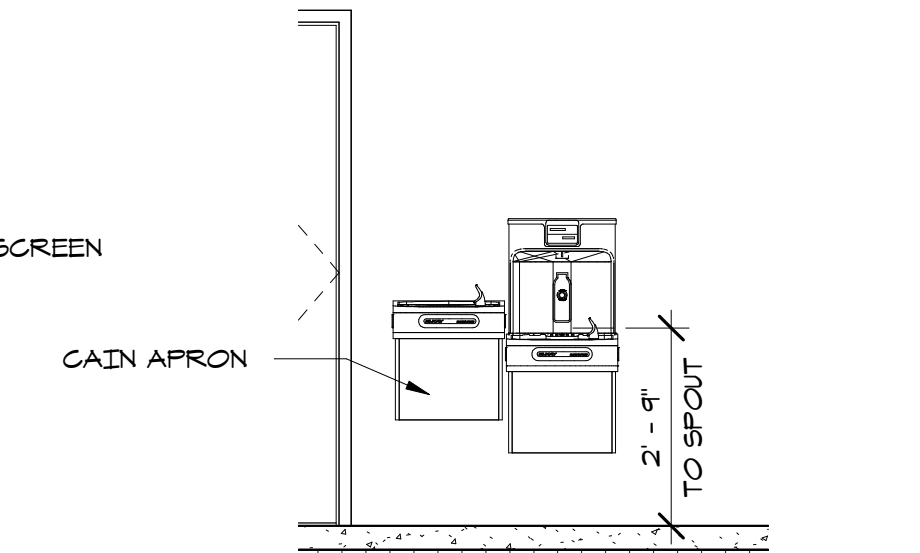

14 Drinking Fountain Elevation
3/8" = 1'-0"

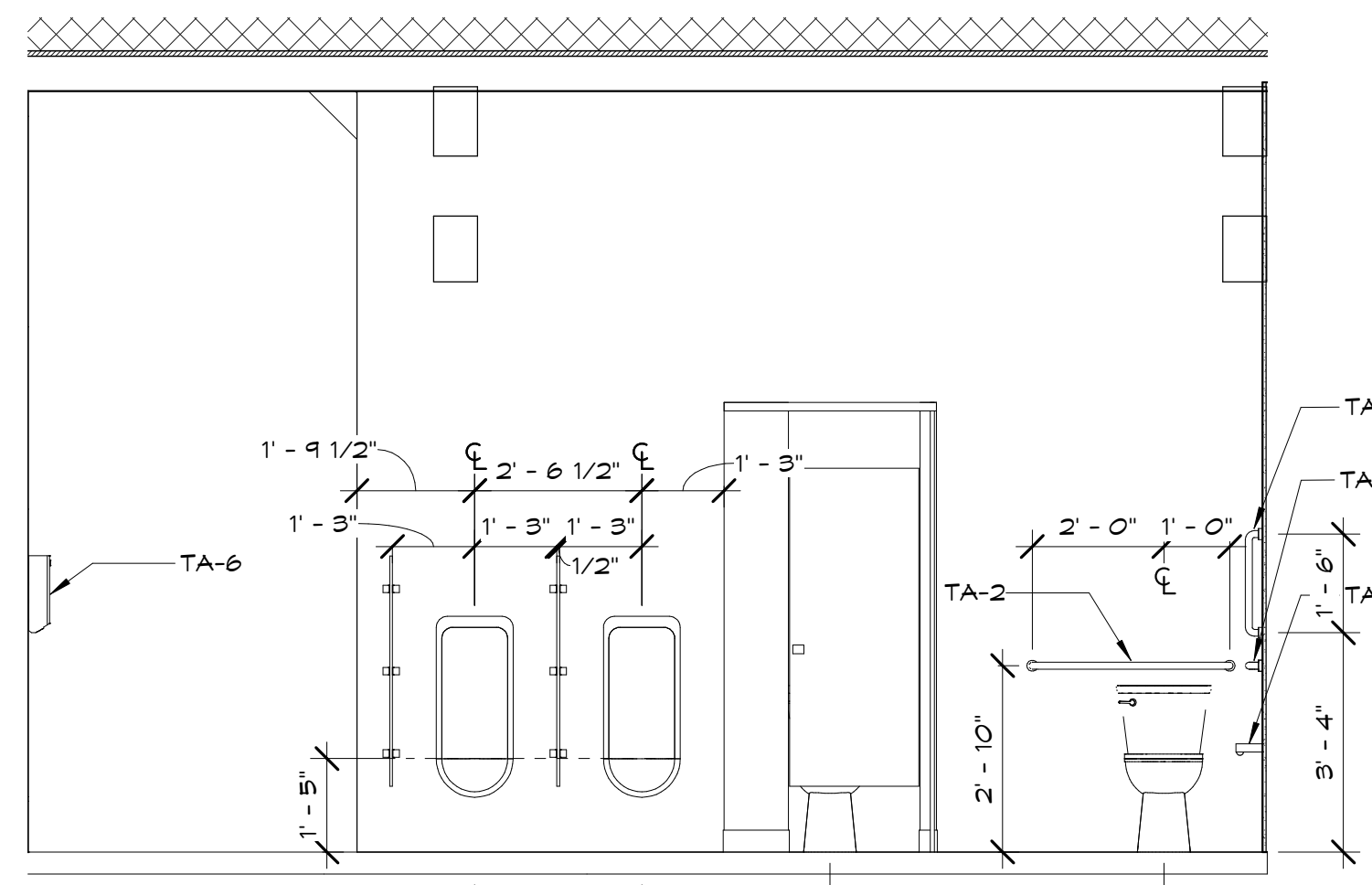

8 Men 103 - D
3/8" = 1'-0"

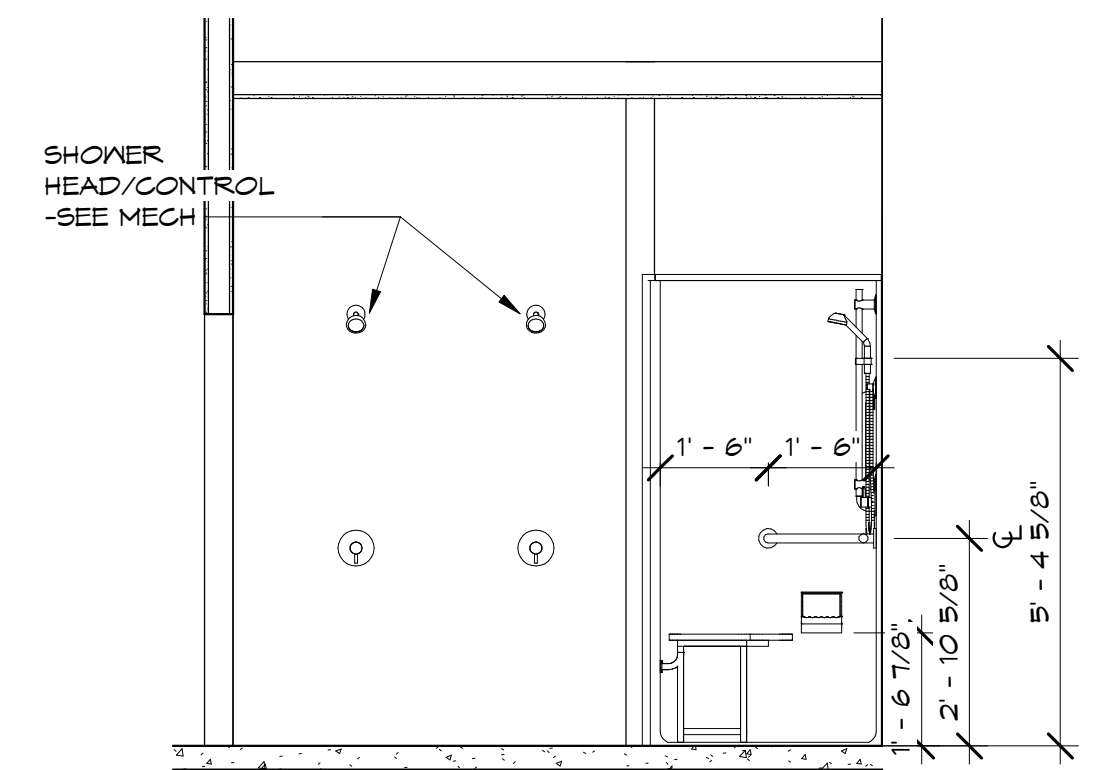

9 Shower 107 - A
3/8" = 1'-0"

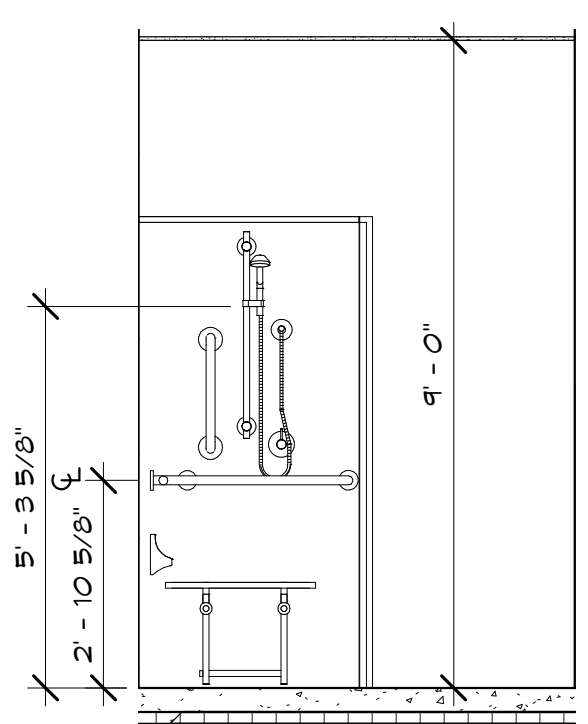

10 Shower 107 - B
3/8" = 1'-0"

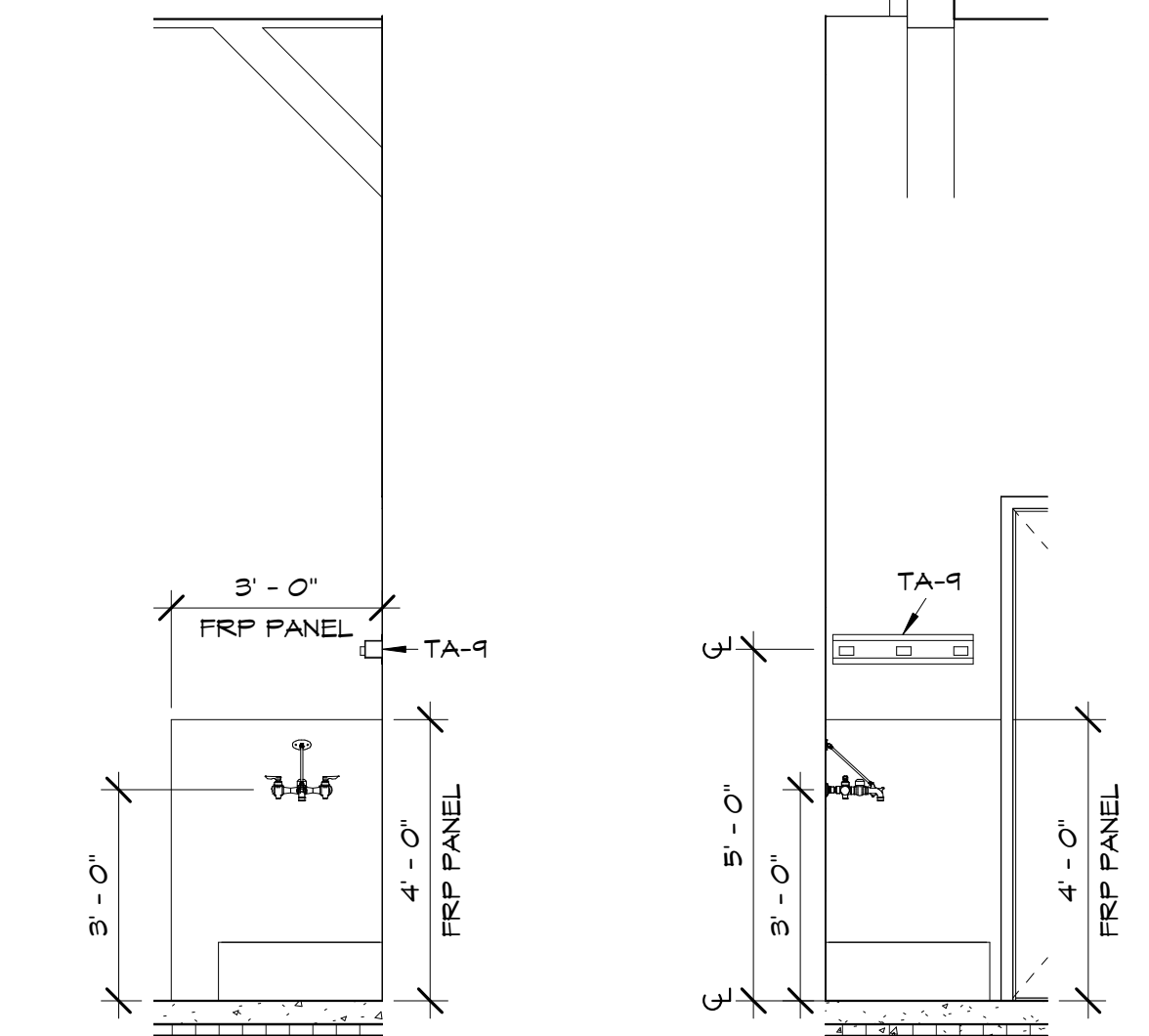

11 Mech 106 - A
3/8" = 1'-0"

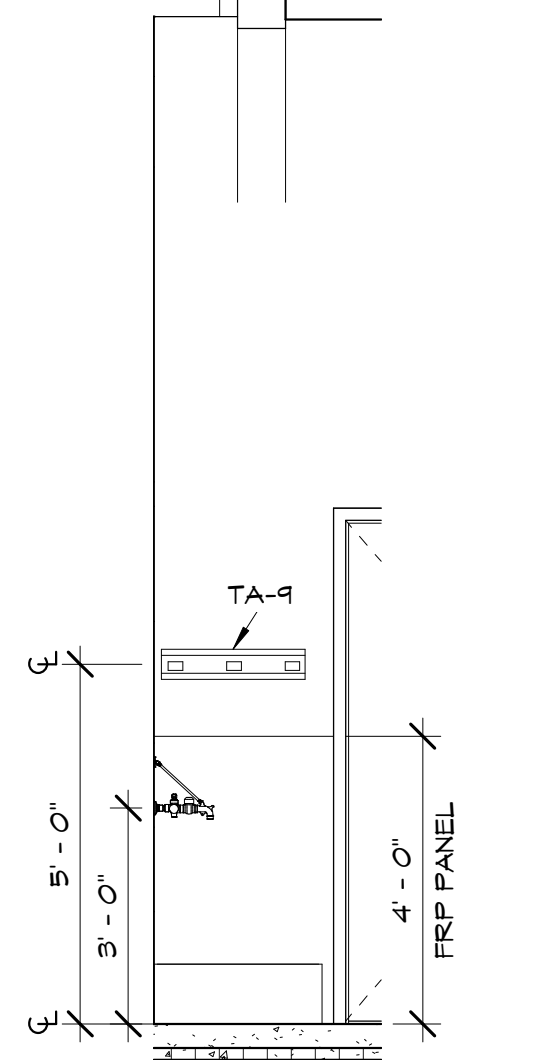

12 Mech 106 - B
3/8" = 1'-0"

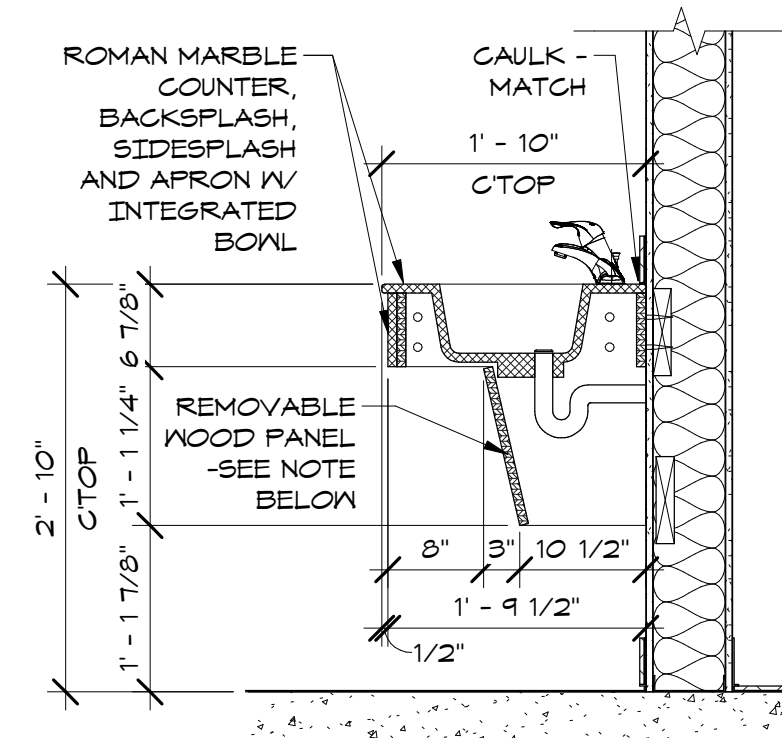

13 ADA Lavatory Section
3/4" = 1'-0"

COPYRIGHT 2023
PETERS AND ASSOCIATES ARCHITECTS P.C.
THESE DOCUMENTS ARE ISSUED BY PETERS
AND ASSOCIATES ARCHITECTS P.C. AND ARE
PROTECTED BY COPYRIGHT LAW. THEY MAY
NOT BE REPRODUCED OR DUPLICATED IN
WHOLE OR IN PART WITHOUT EXPRESS
WRITTEN PERMISSION OF PETERS AND
ASSOCIATES ARCHITECTS P.C., BELLEVUE, NE.

REVISIONS
SEPTEMBER 15, 2023
PROJECT #: 23-04

INTERIOR ELEVATIONS AND DETAILS,
TOILET ACCESSORY SCHEDULE

PENDER PUBLIC SCHOOLS
SPORTS COMPLEX BUILDING
PENDER, NEBRASKA

PETERS & ASSOCIATES
ARCHITECTS, P.C.
SUITE E
68005
BELLEVUE, NEBRASKA 482-885-8858
PHONE

FOR
REVIEW
ONLY
NOT FOR
CONSTRUCTION

A-2.1

9/15/2023 4:04:12 AM BIM 360://23-04-PPS_Sports Complex Building/PPS_SportsComplex_Masters.rvt

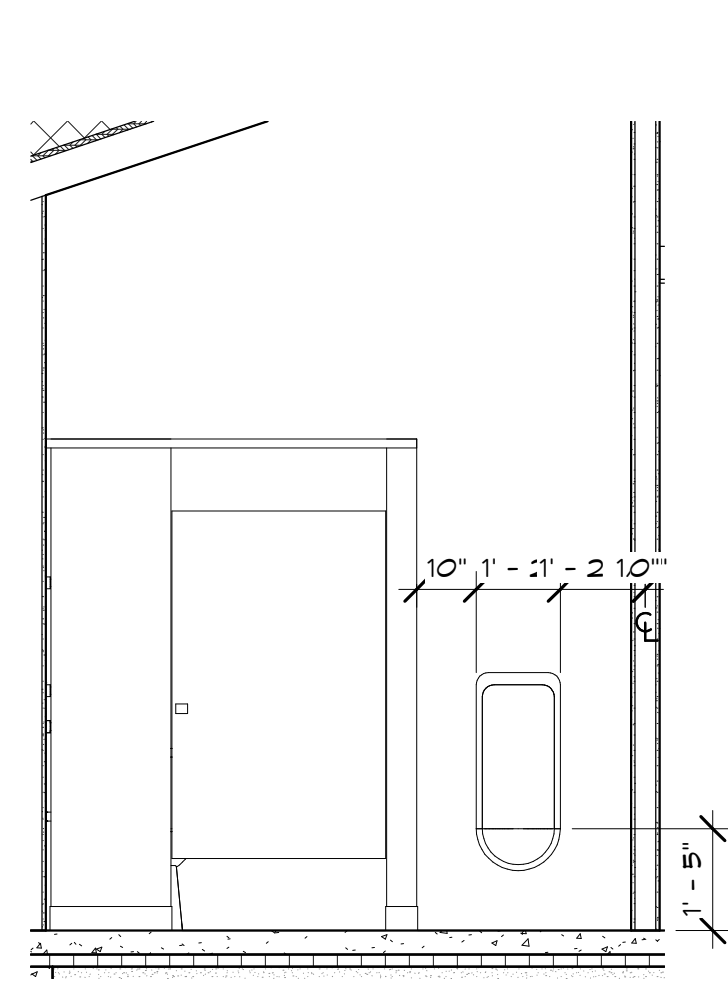

1 Toilet 108 - A
3/8" = 1'-0"

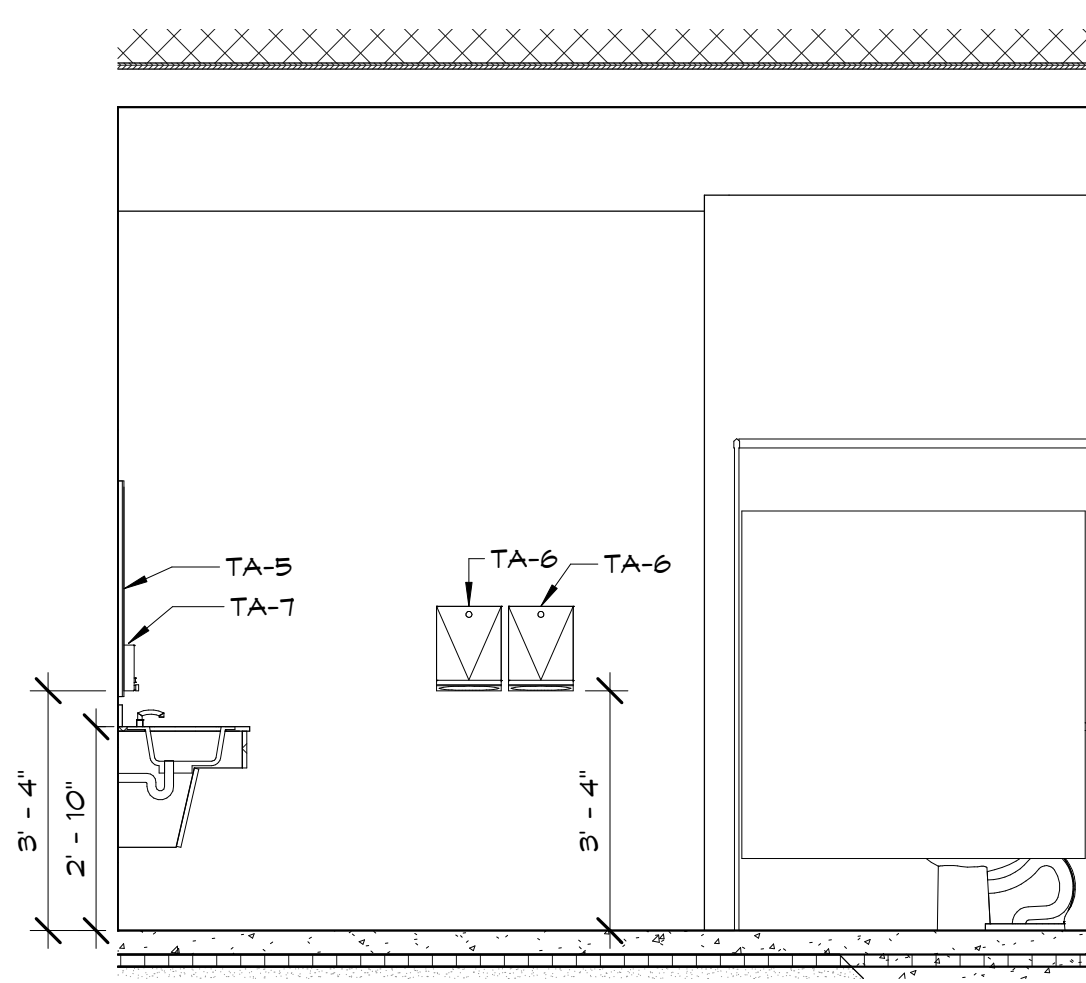

2 Toilet 108 - B
3/8" = 1'-0"

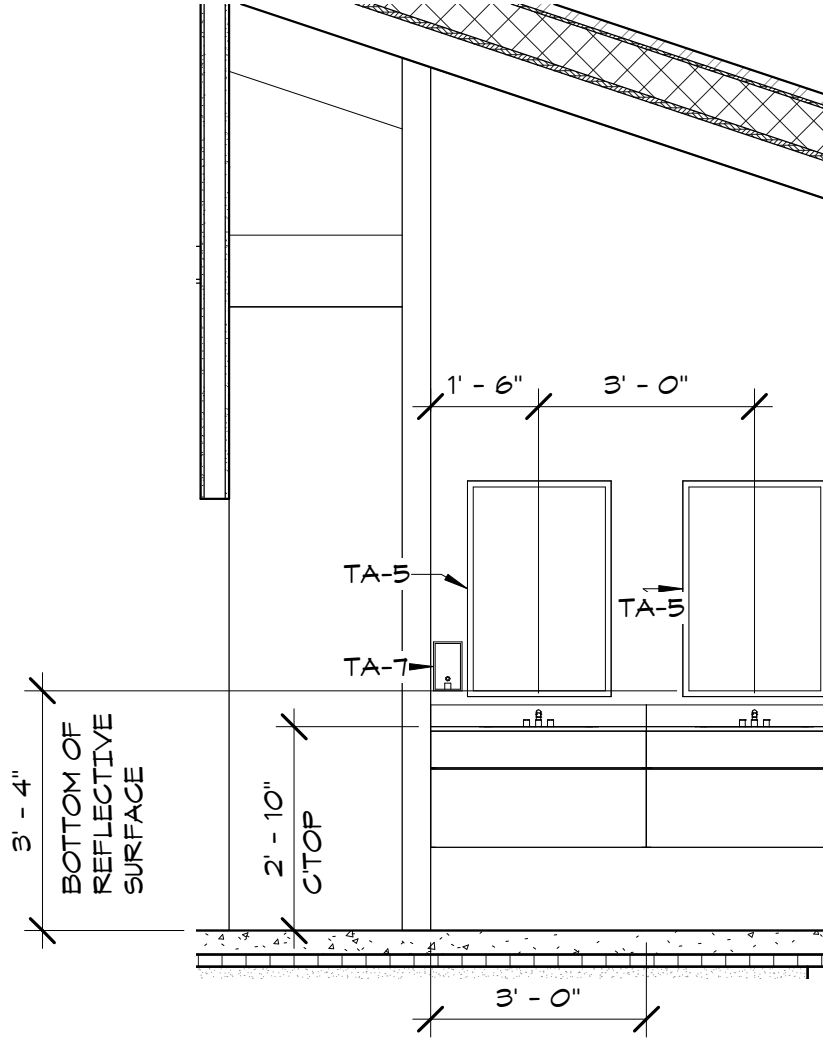

3 Toilet 108 - C
3/8" = 1'-0"



4 Concessions 104 - A
3/8" = 1'-0"

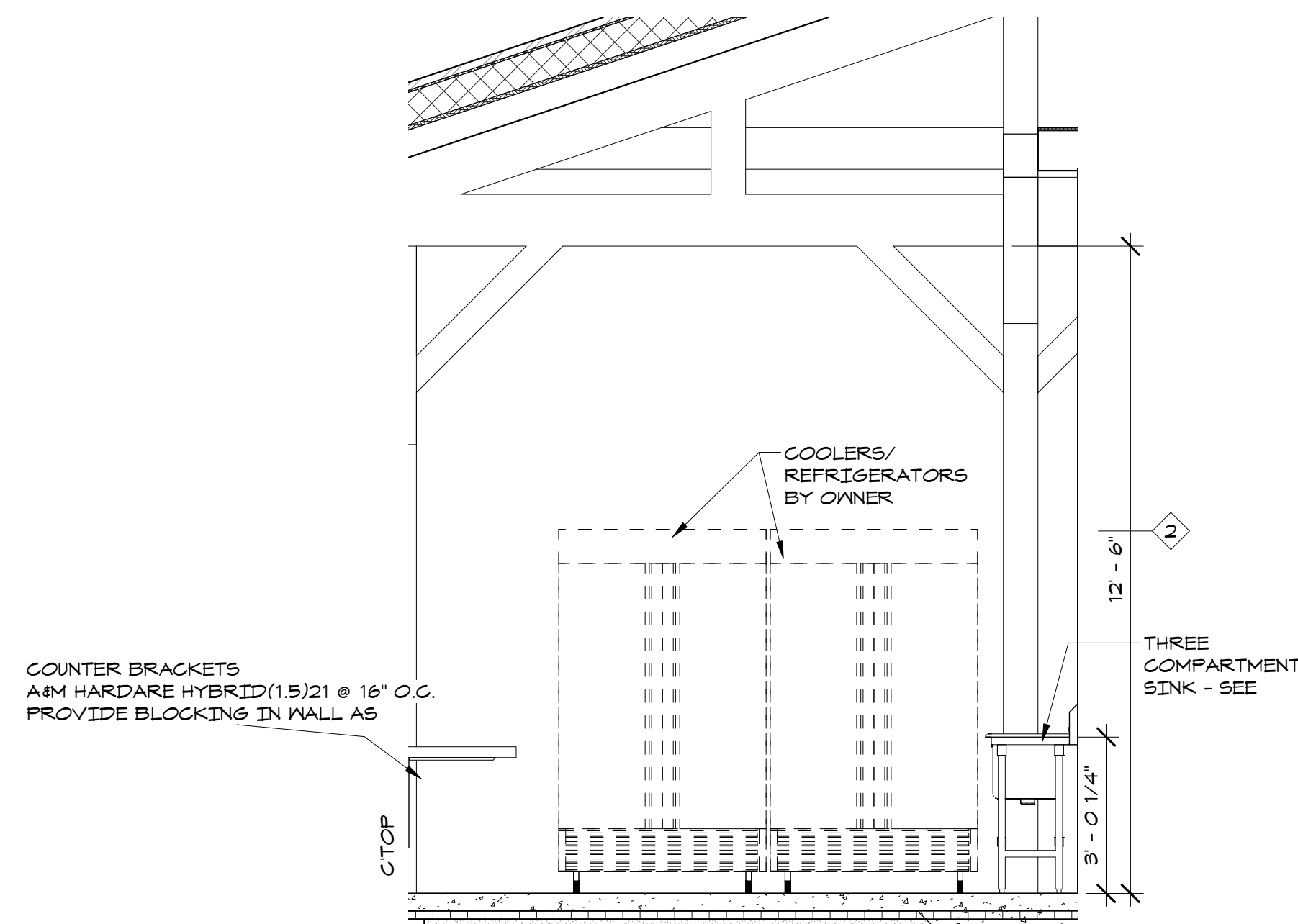

5 Concessions 104 - B
3/8" = 1'-0"

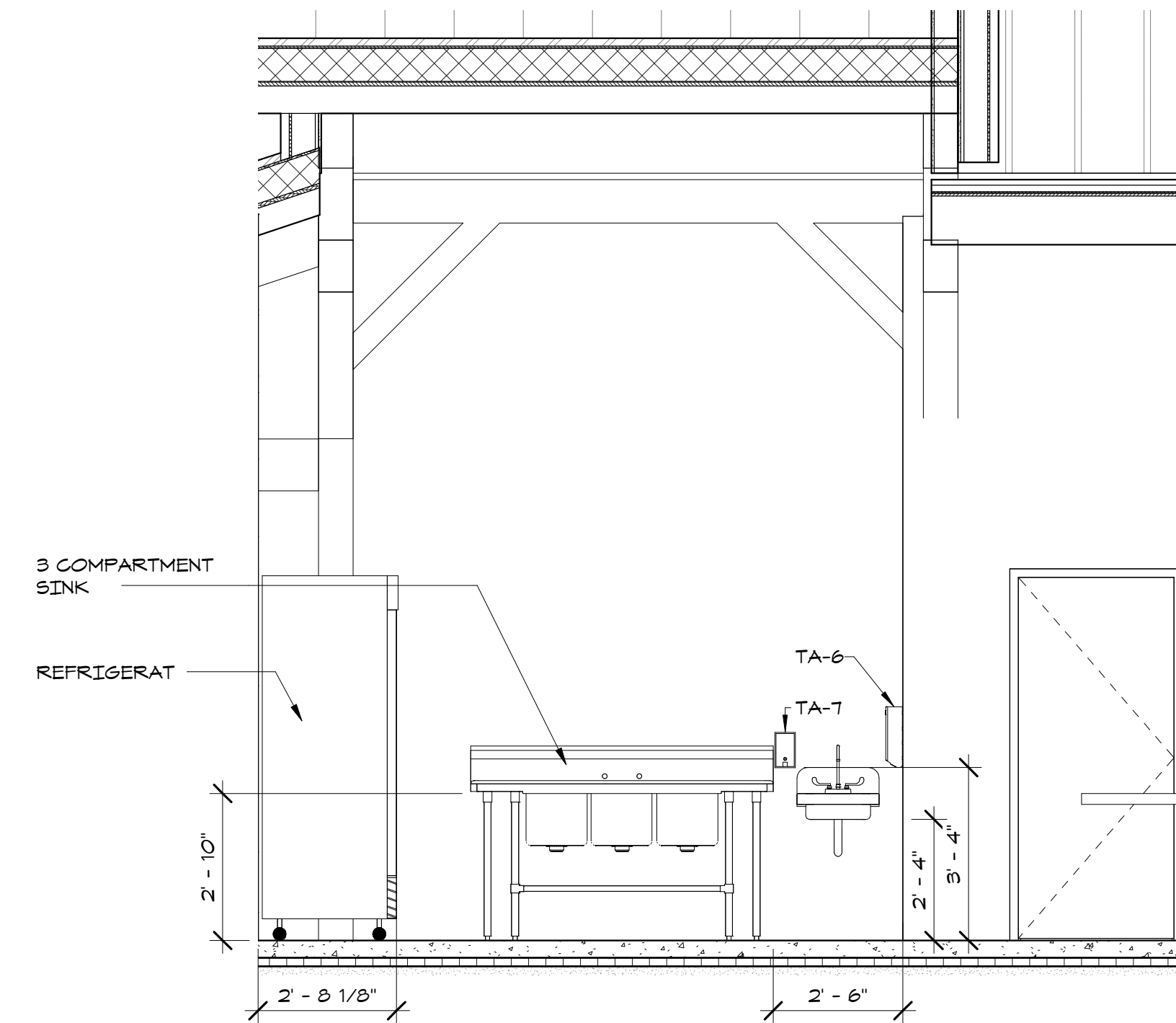

6 Concessions 104 - C
3/8" = 1'-0"

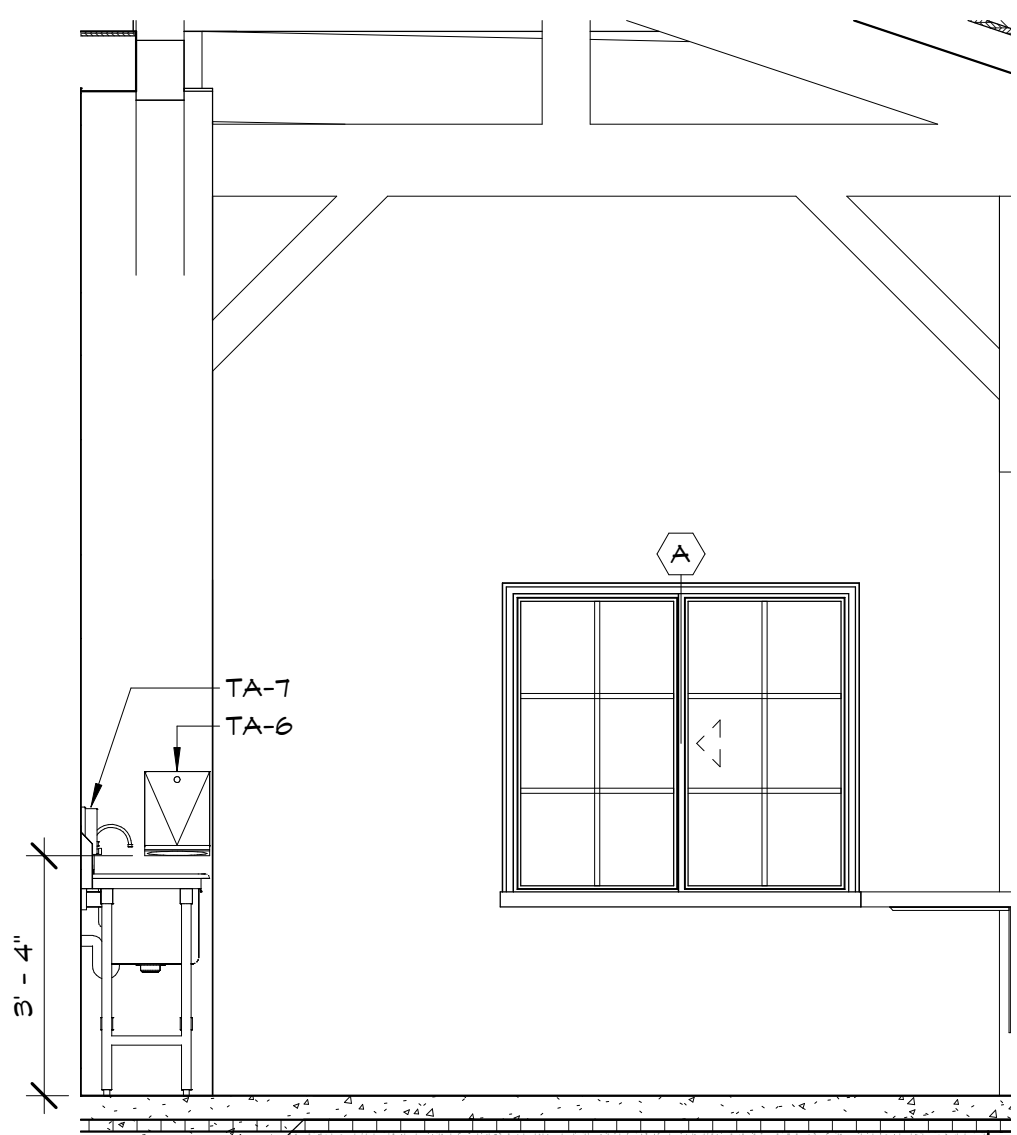

7 Concessions 104 - D
3/8" = 1'-0"

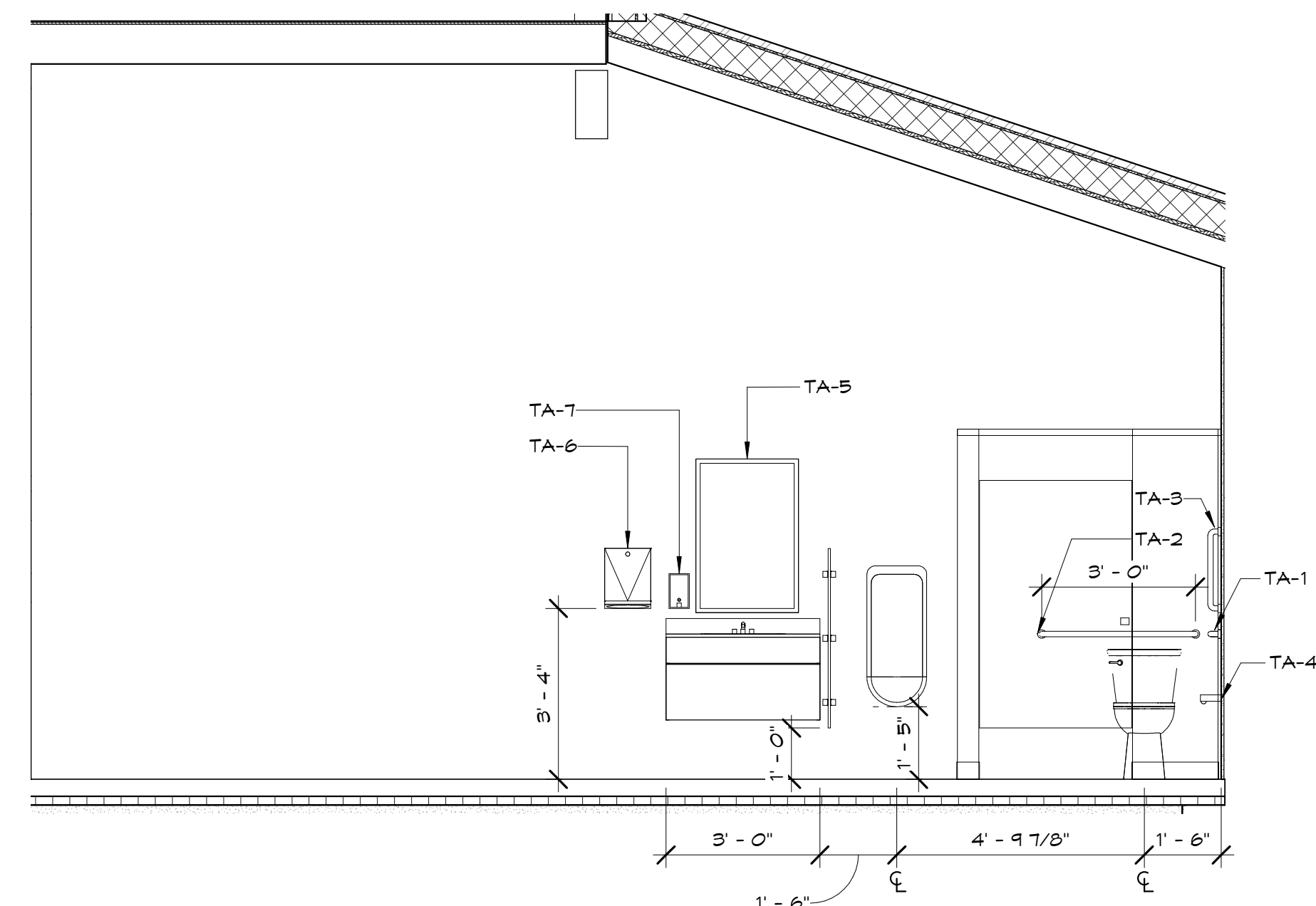

8 Home Locker Room 102 - A
3/8" = 1'-0"

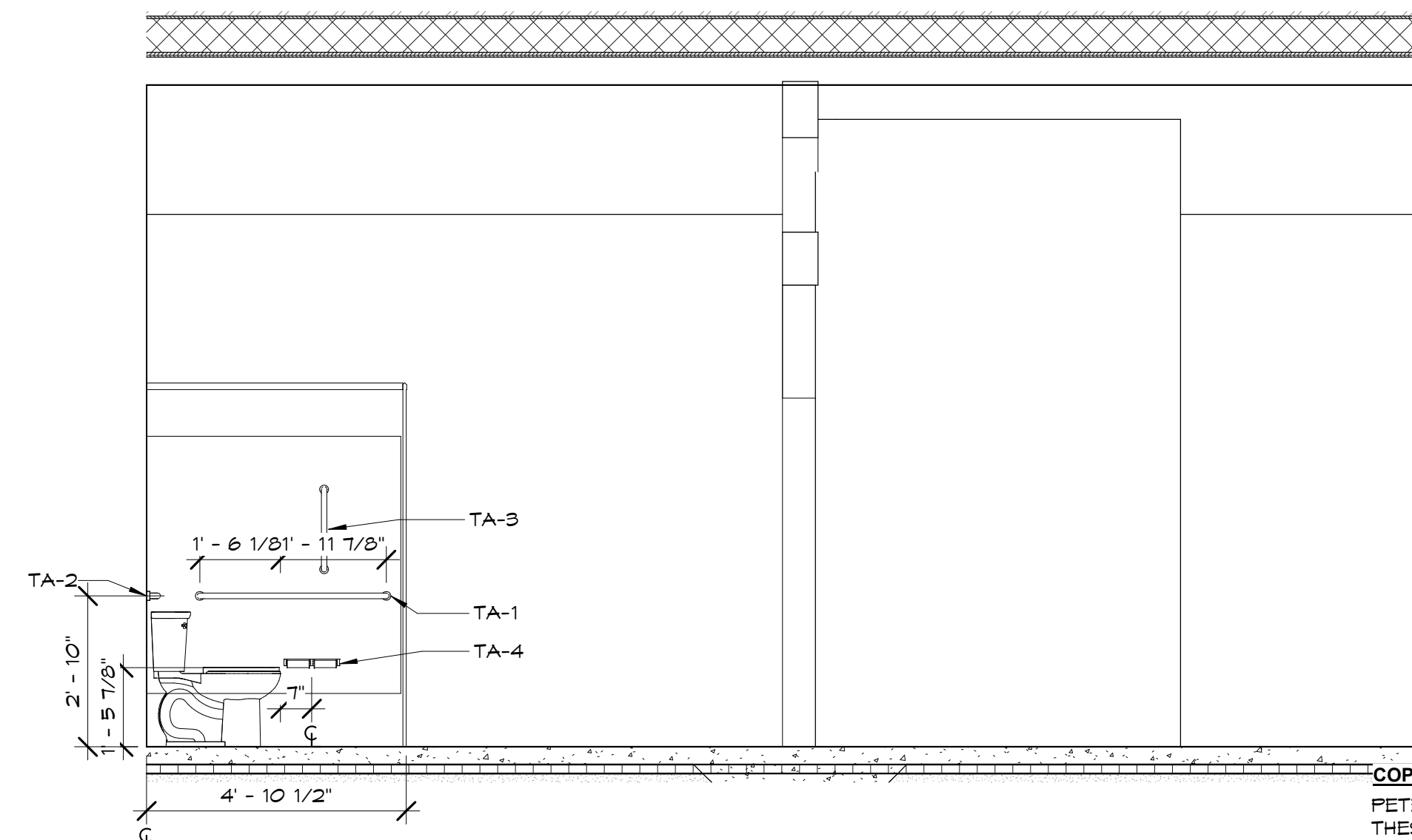

9 Home Locker Room 102 - B
3/8" = 1'-0"

COPYRIGHT 2023

PETERS AND ASSOCIATES ARCHITECTS P.C.
THESE DOCUMENTS ARE ISSUED BY PETERS
AND ASSOCIATES ARCHITECTS P.C. AND ARE
PROTECTED BY COPYRIGHT LAW. THEY MAY
NOT BE REPRODUCED OR DUPLICATED IN
WHOLE OR IN PART WITHOUT EXPRESS
WRITTEN PERMISSION OF PETERS AND
ASSOCIATES ARCHITECTS P.C., BELLEVUE, NE.

REVISIONS
SEPTEMBER 15, 2023
PROJECT #: 23-01

INTERIOR ELEVATION AND DETAILS

PENDER PUBLIC SCHOOLS
SPORTS COMPLEX BUILDING
PENDER, NEBRASKA

PETERS & ASSOCIATES
ARCHITECTS, P.C.
1103 GALVIN ROAD SOUTH, SUITE 6000
BELLEVUE, NEBRASKA 68005
PHONE: 402-885-8582

FOR
REVIEW
ONLY
NOT FOR
CONSTRUCTION

A-2.2

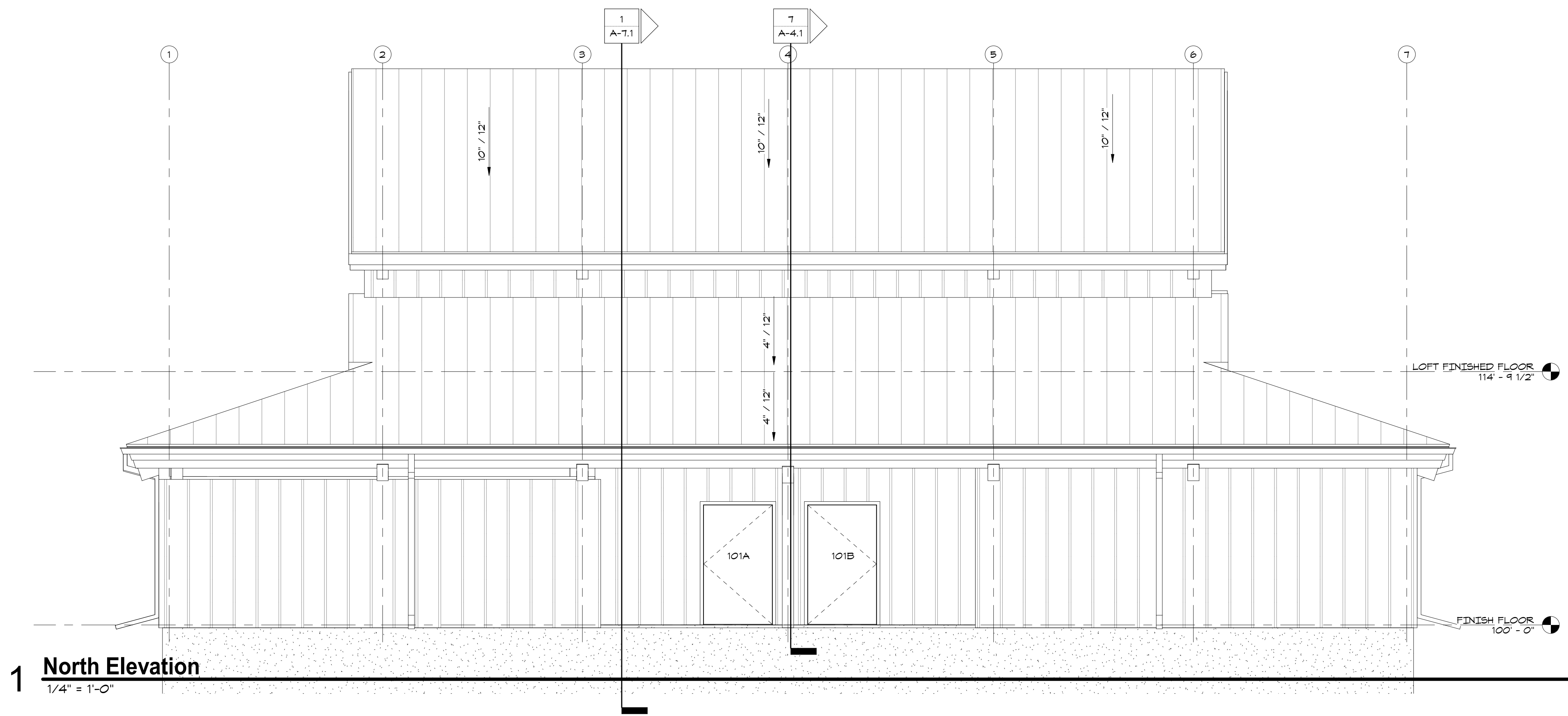

1 North Elevation
1/4" = 1'-0"

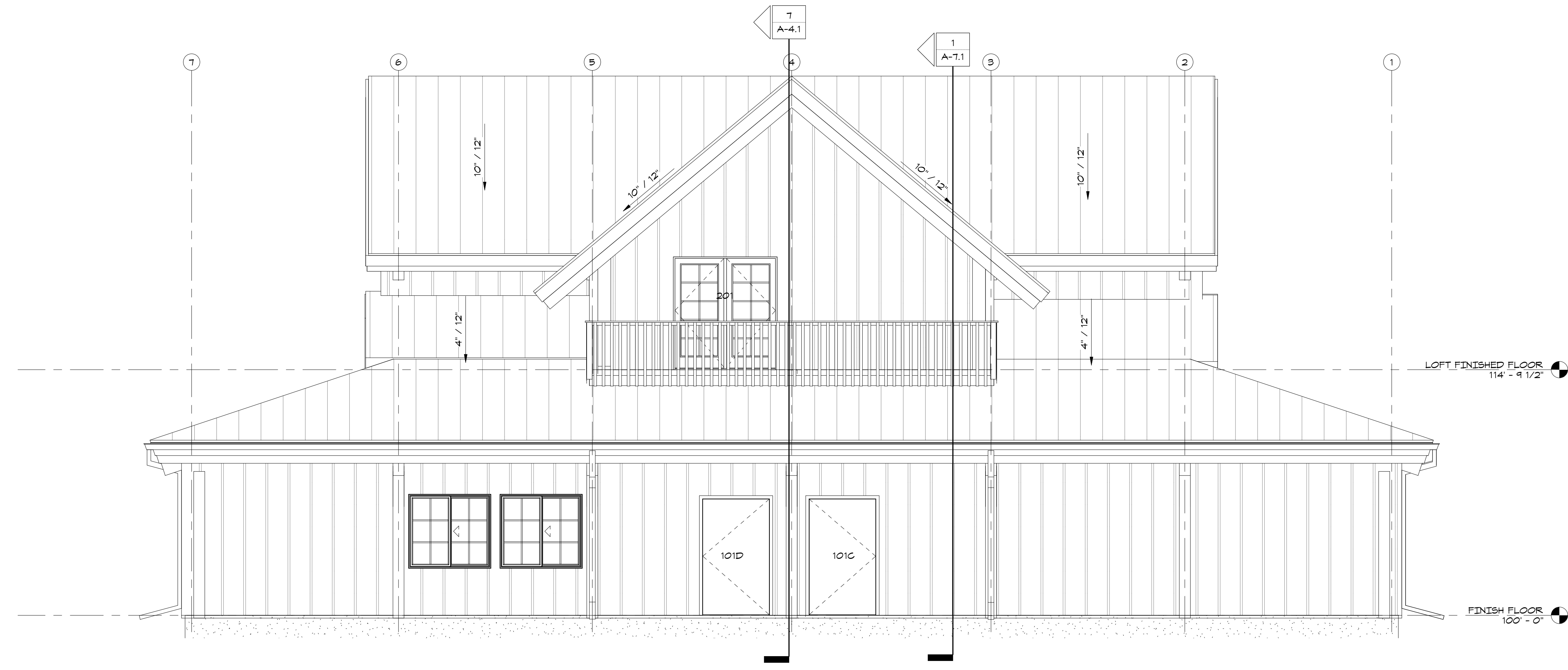

2 South Elevation
1/4" = 1'-0"

REVISIONS	SEPTEMBER 15, 2023	PROJECT #: 23-04
-----------	--------------------	------------------

ELEVATIONS

**PENDER PUBLIC SCHOOLS
SPORTS COMPLEX BUILDING**
PENDER, NEBRASKA

**PETERS & ASSOCIATES
ARCHITECTS, P.C.**
1103 GALVIN ROAD SOUTH, SUITE 6000
BELLEVUE, NEBRASKA 402-885-2522
PHONE: 402-885-2522

FOR REVIEW ONLY
NOT FOR CONSTRUCTION

A-3.1

COPYRIGHT 2023
PETERS AND ASSOCIATES ARCHITECTS P.C.
THESE DOCUMENTS ARE ISSUED BY PETERS
AND ASSOCIATES ARCHITECTS P.C. AND ARE
PROTECTED BY COPYRIGHT LAW. THEY MAY
NOT BE REPRODUCED OR DUPLICATED IN
WHOLE OR IN PART WITHOUT EXPRESS
WRITTEN PERMISSION OF PETERS AND
ASSOCIATES ARCHITECTS P.C., BELLEVUE, NE.

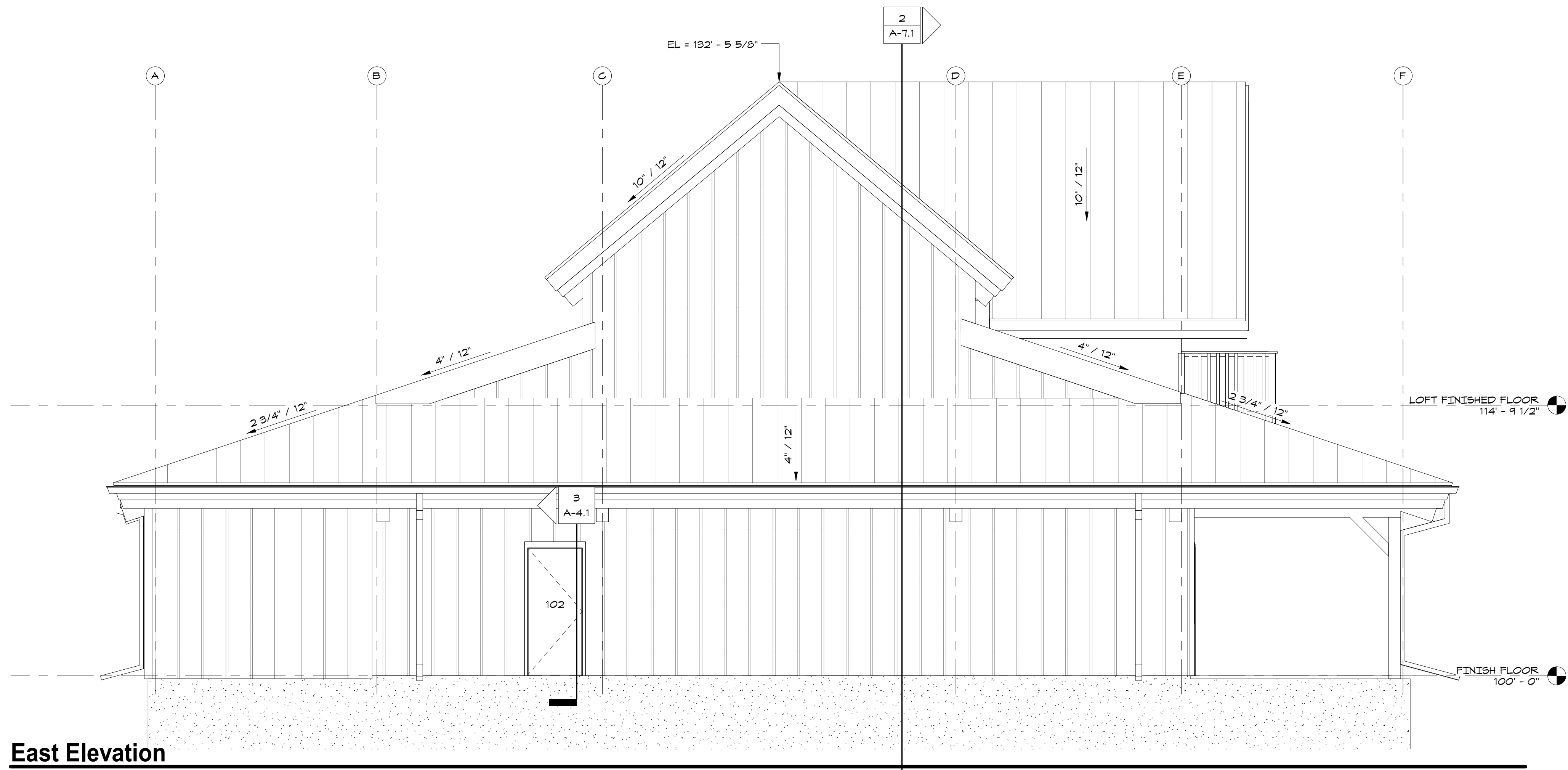

1 East Elevation
1/4" = 1'-0"

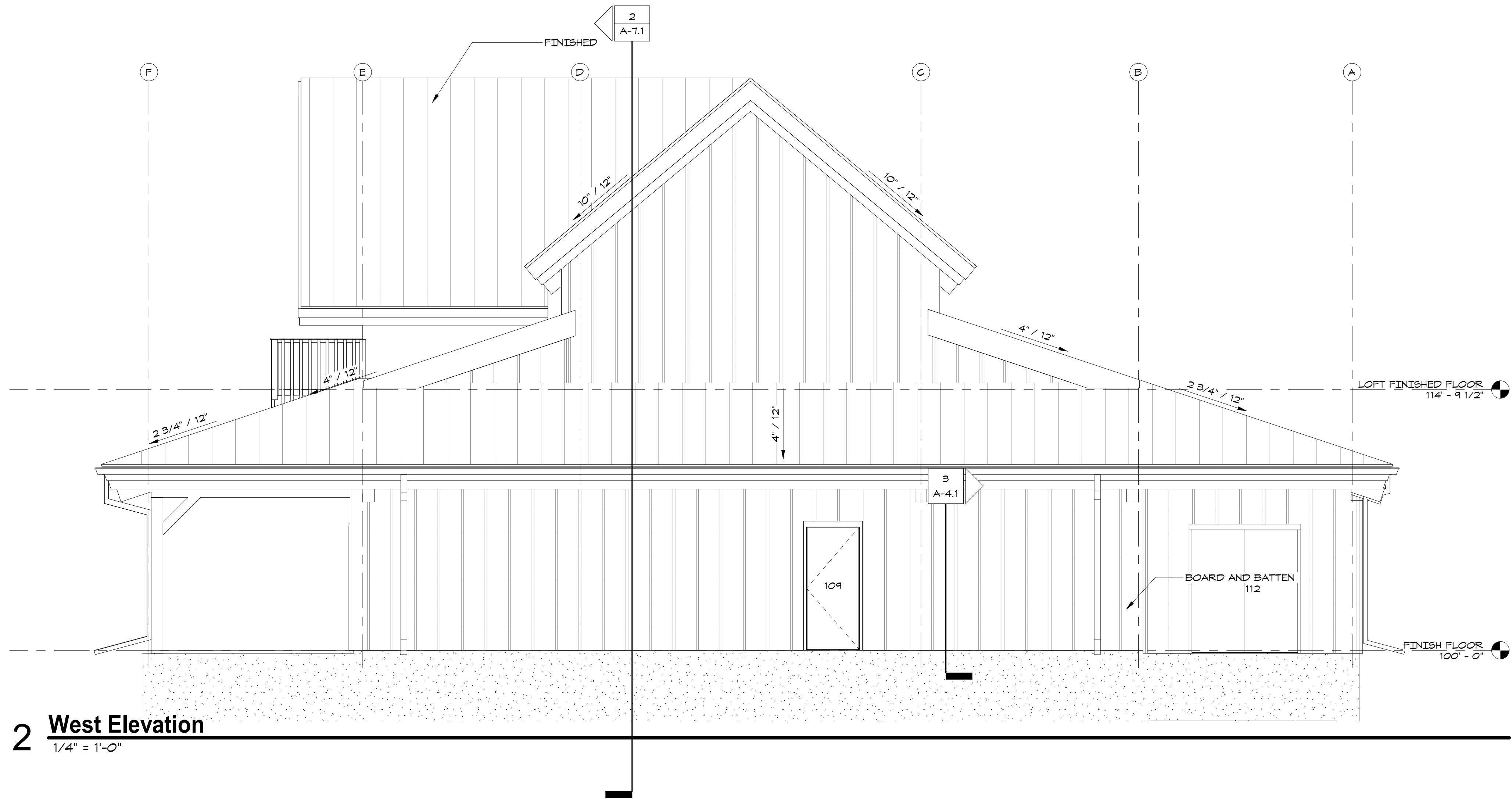

2 West Elevation
1/4" = 1'-0"

REVISIONS	SEPTEMBER 15, 2023	PROJECT #: 23-01
-----------	--------------------	------------------

ELEVATIONS

**PENDER PUBLIC SCHOOLS
SPORTS COMPLEX BUILDING**
PENDER, NEBRASKA

**PETERS & ASSOCIATES
ARCHITECTS, P.C.**
1103 GALVIN ROAD SOUTH, SUITE 6000
BELLEVUE, NEBRASKA 402-885-2522

FOR REVIEW ONLY
NOT FOR CONSTRUCTION

A-3.2

COPYRIGHT 2023
PETERS AND ASSOCIATES ARCHITECTS P.C.
THESE DOCUMENTS ARE ISSUED BY PETERS
AND ASSOCIATES ARCHITECTS P.C. AND ARE
PROTECTED BY COPYRIGHT LAW. THEY MAY
NOT BE REPRODUCED OR DUPLICATED IN
WHOLE OR IN PART WITHOUT EXPRESS
WRITTEN PERMISSION OF PETERS AND
ASSOCIATES ARCHITECTS P.C., BELLEVUE, NE.

9/15/2023 1:01:14 AM E:\360\23-01\PS - Sports Complex Building\PS-SportsComplex-Mainroom.rvt

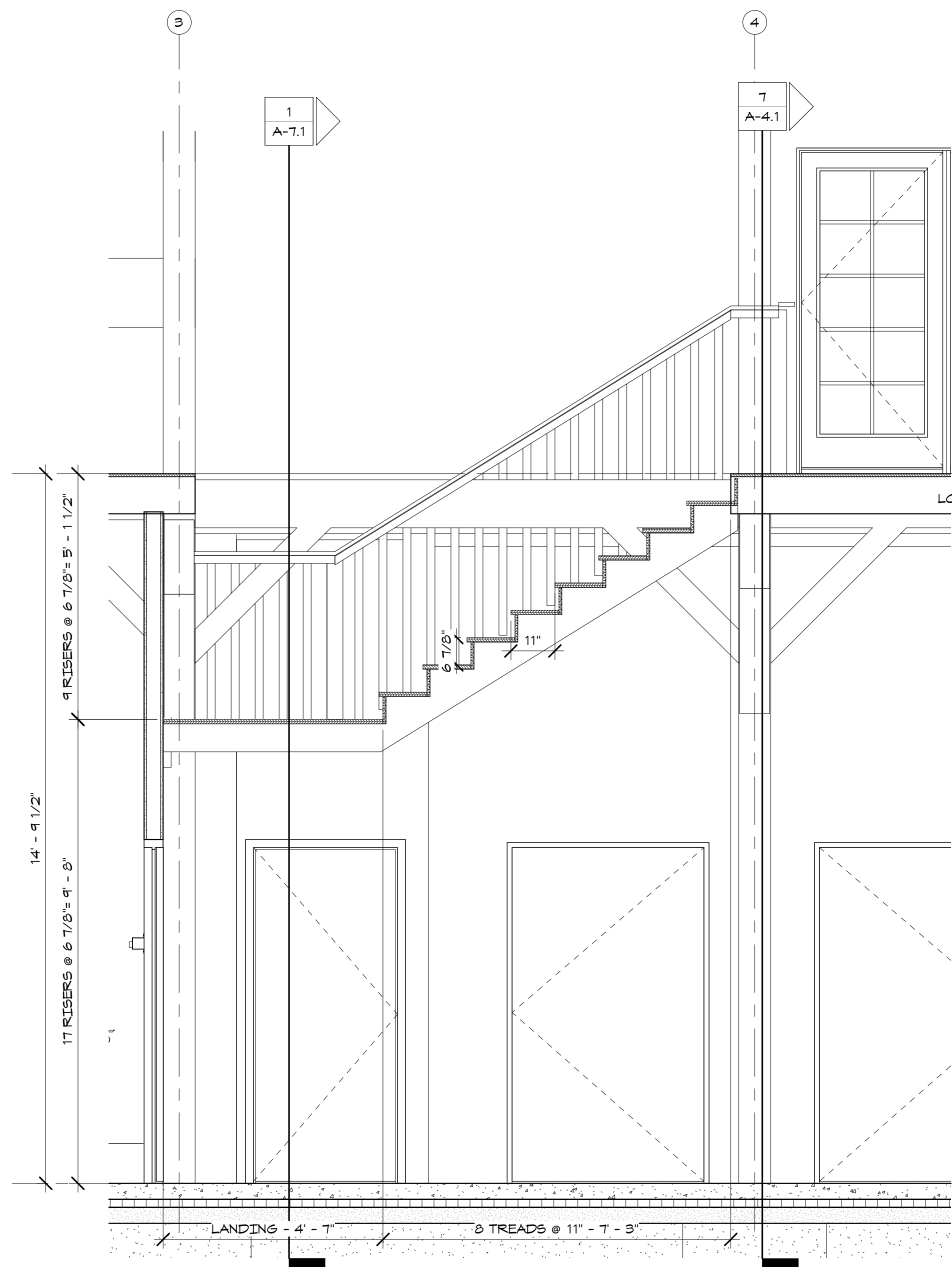

1 Stair Section A
1/2" = 1'-0"

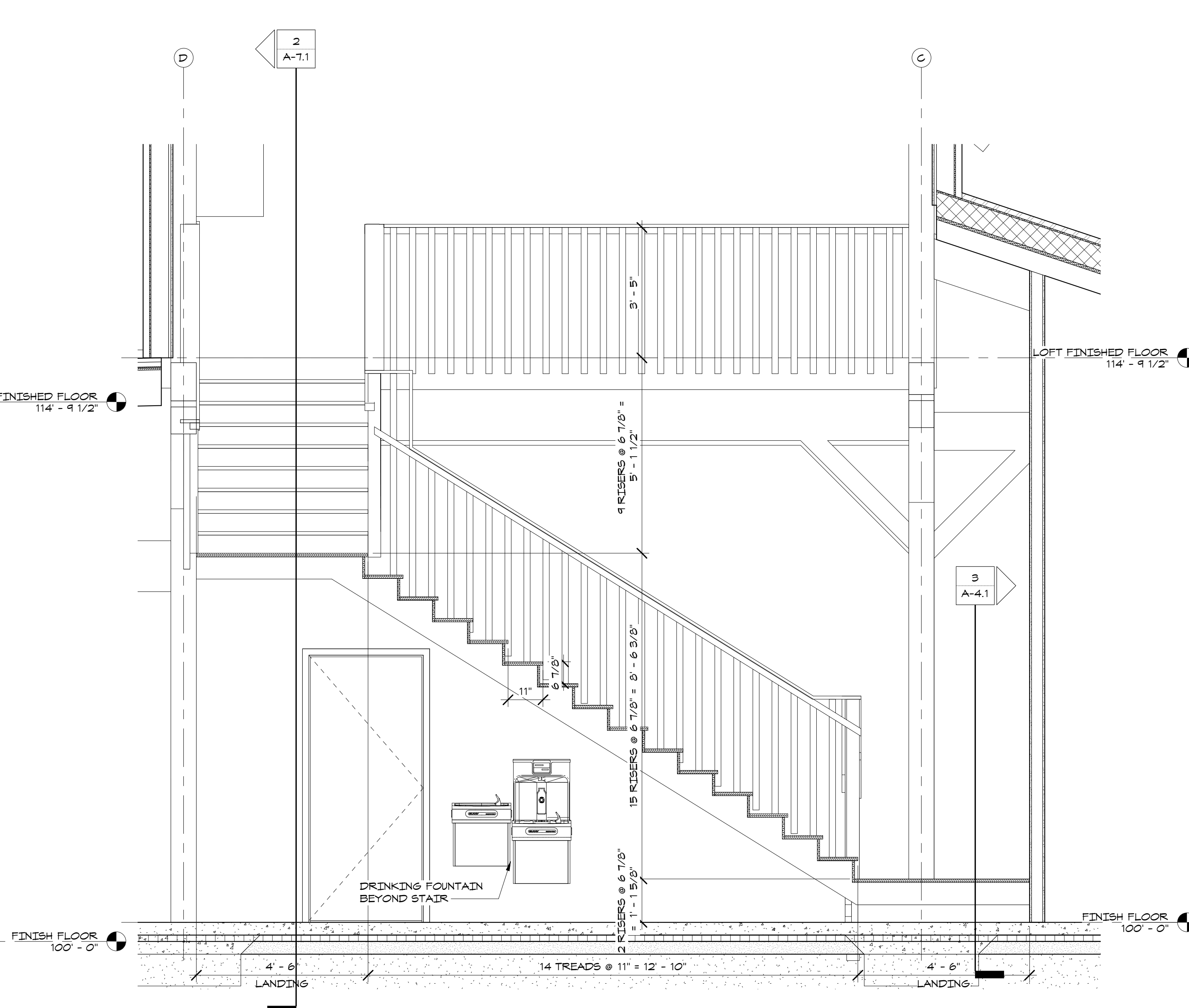

2 Stair Section B
1/2" = 1'-0"

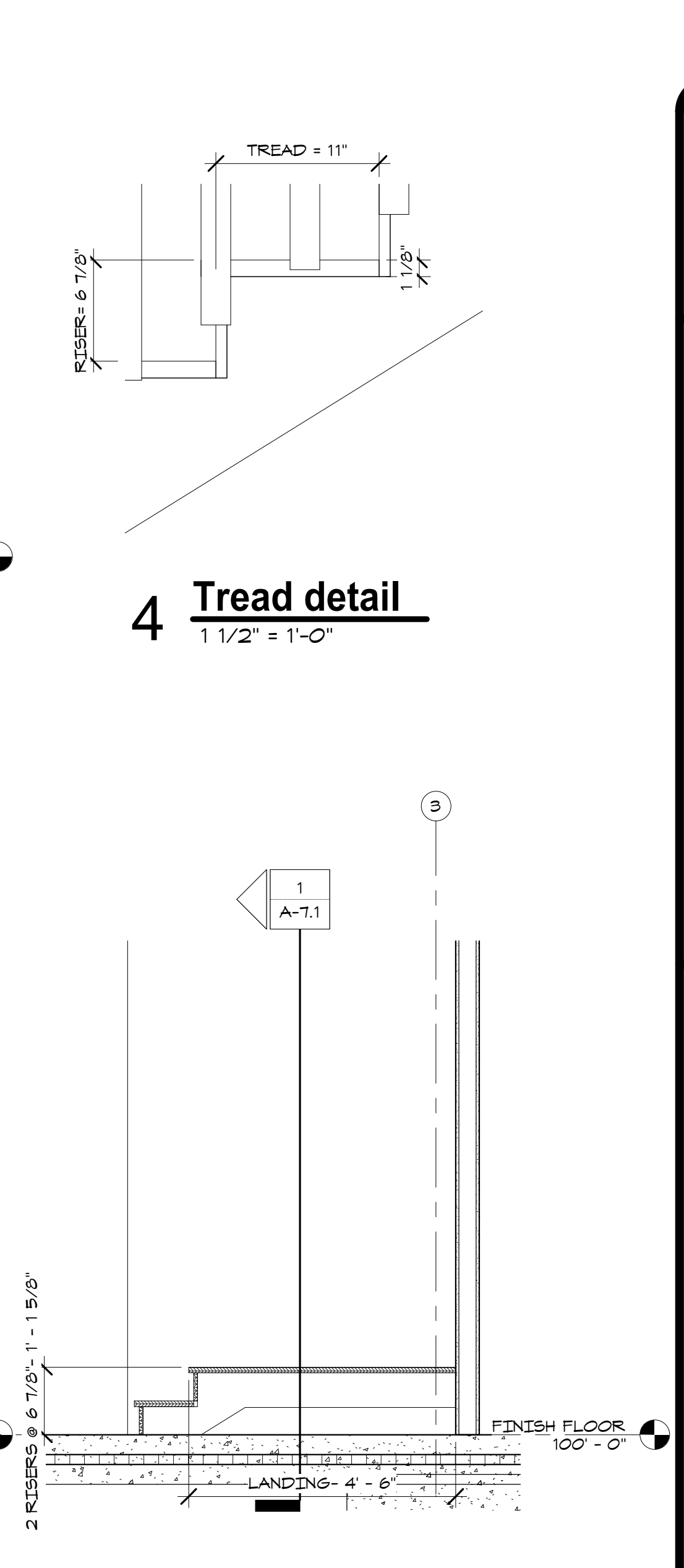

3 Stair Section C
1/2" = 1'-0"

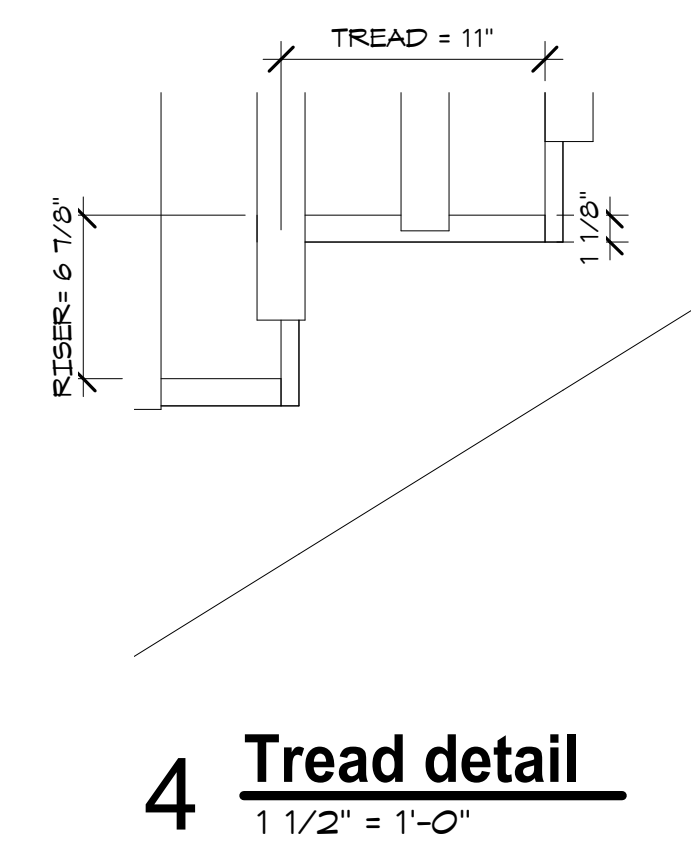

4 Tread detail
1 1/2" = 1'-0"

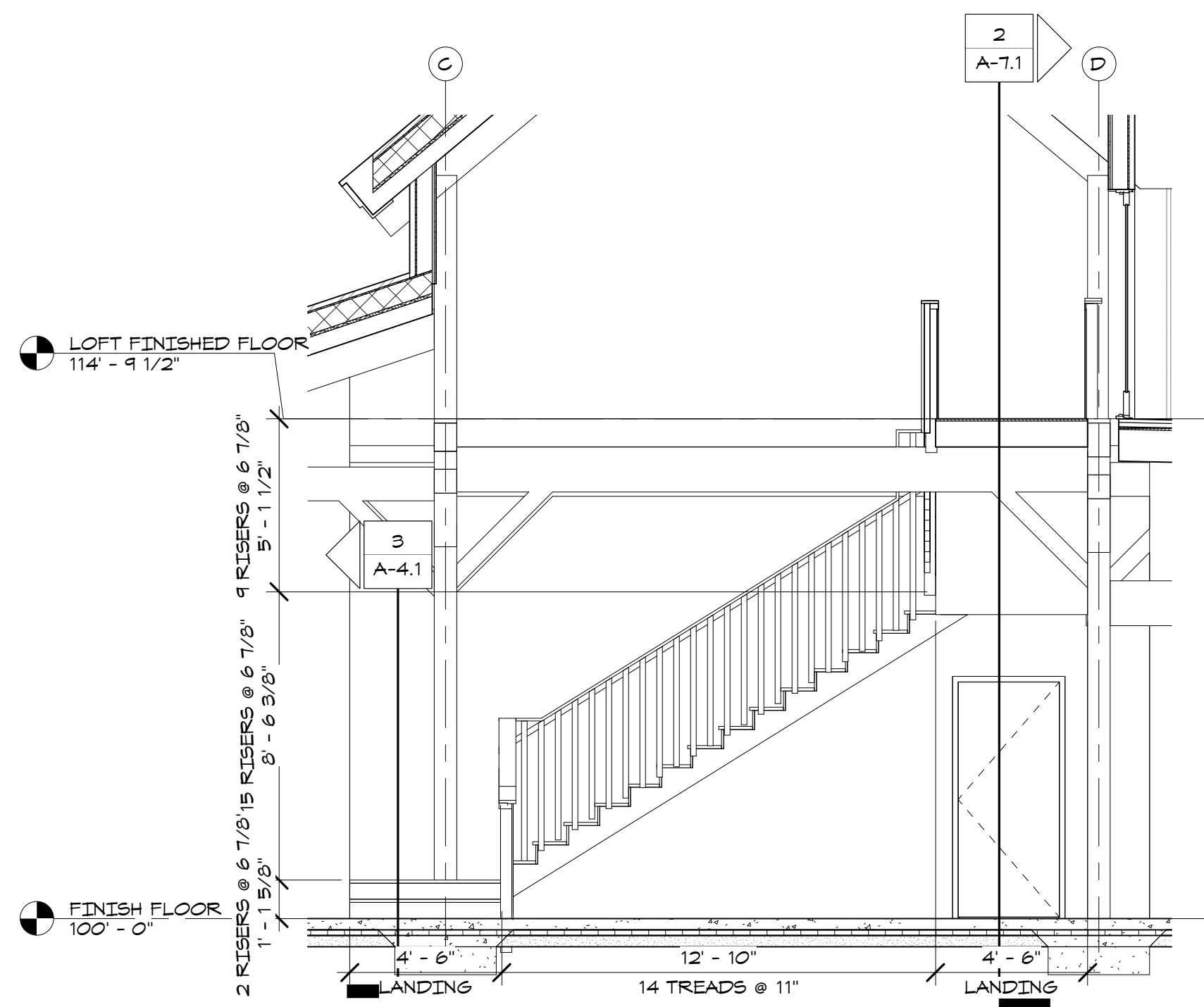

5 Elevation 1 - a
1/4" = 1'-0"

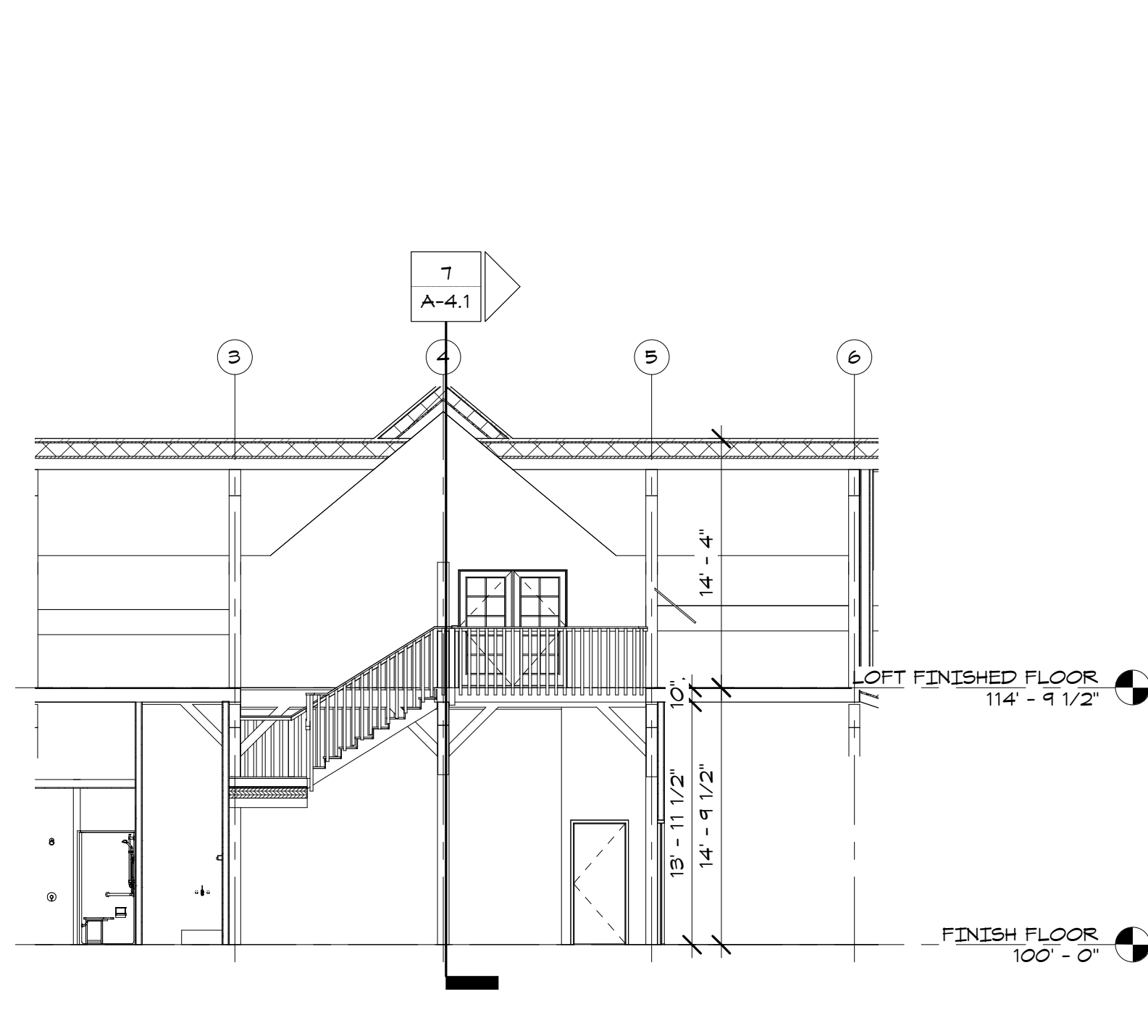

6 Loft bridge elevation
1/8" = 1'-0"

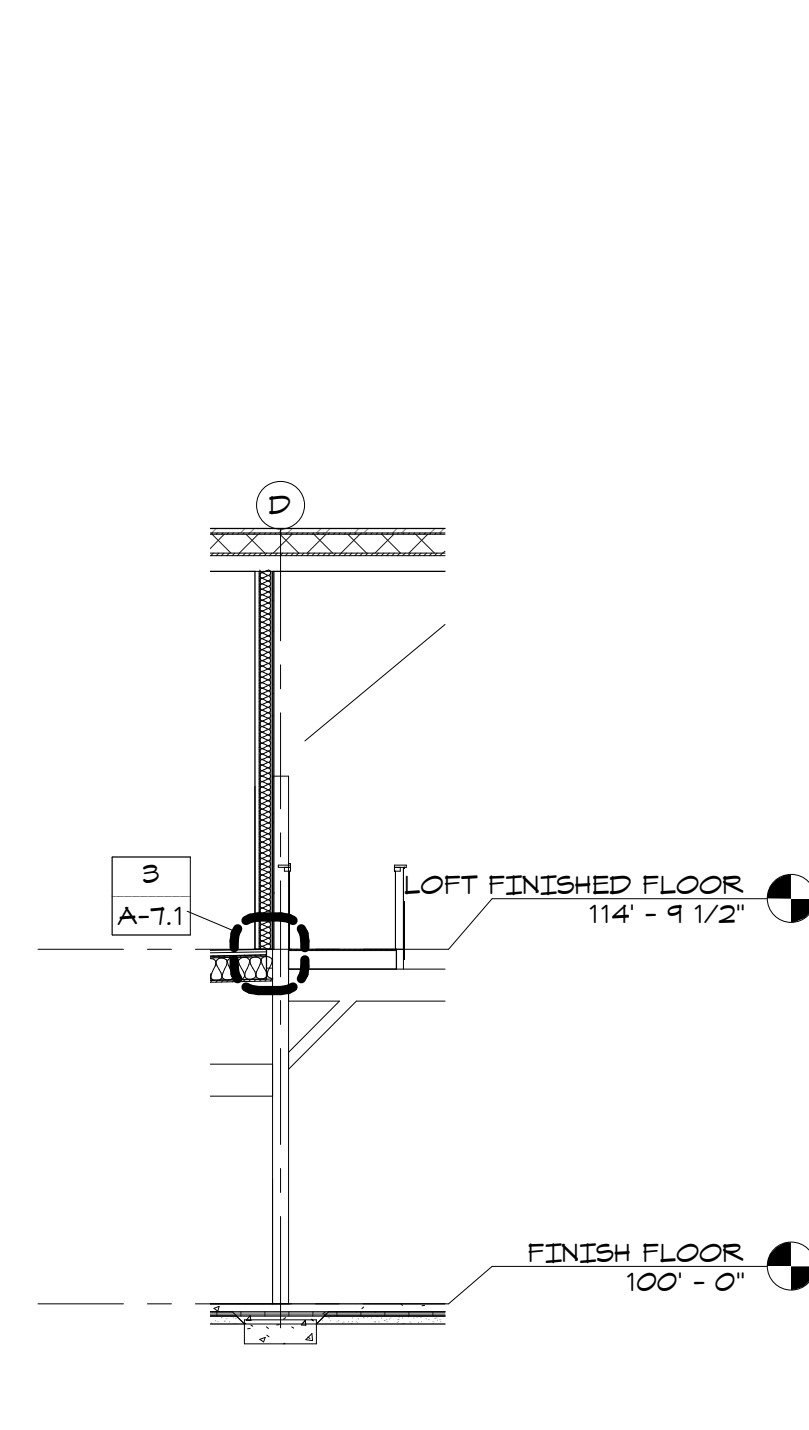

7 Loft bridge section
1/8" = 1'-0"

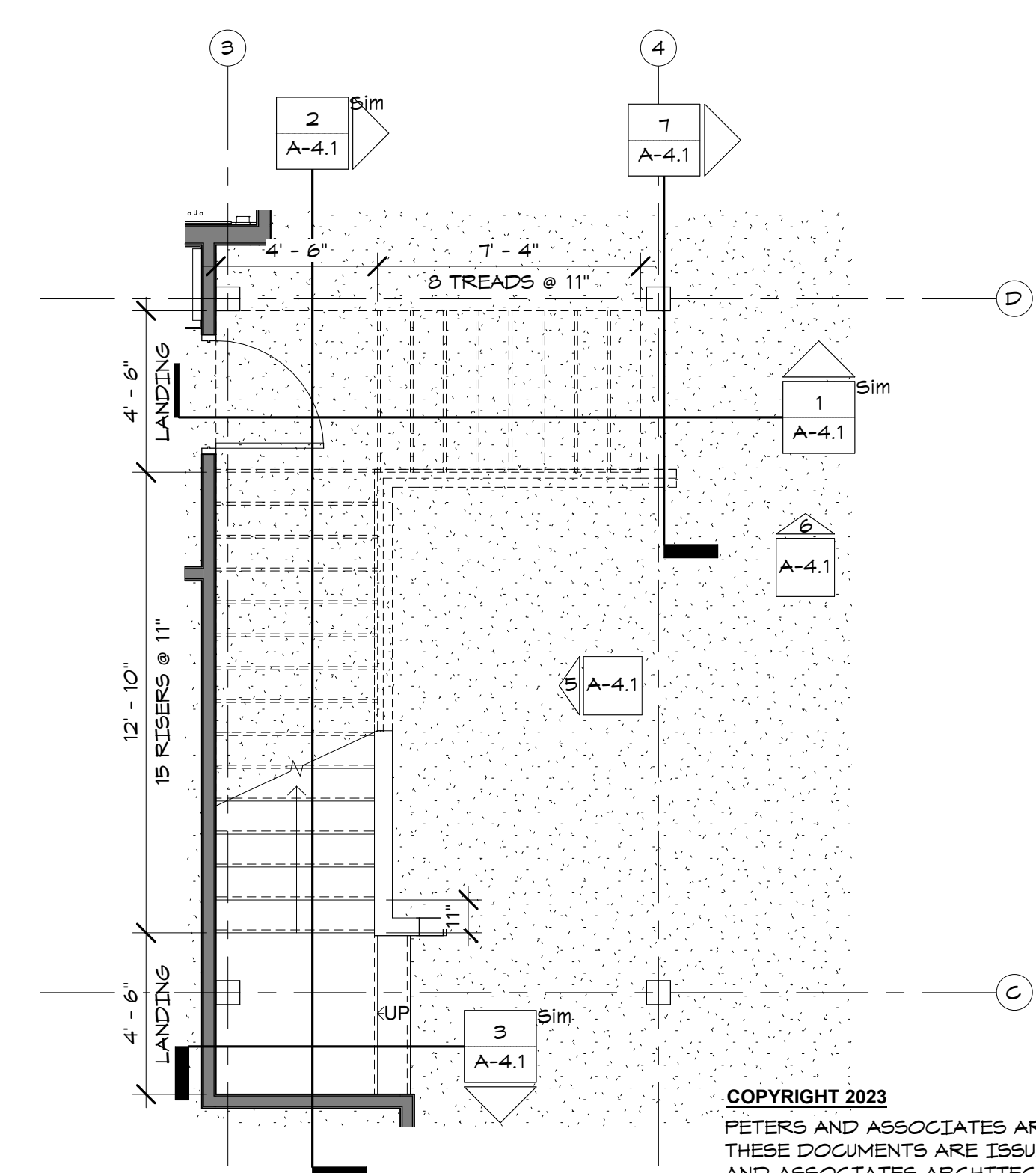

8 Floor Plan - Stairs
1/4" = 1'-0"

COPYRIGHT 2023
PETERS AND ASSOCIATES ARCHITECTS P.C.
AND ASSOCIATES ARCHITECTS P.C. AND ARE
PROTECTED BY COPYRIGHT LAW. THEY MAY
NOT BE REPRODUCED OR DUPLICATED IN
WHOLE OR IN PART WITHOUT EXPRESS
WRITTEN PERMISSION OF PETERS AND
ASSOCIATES ARCHITECTS P.C., BELLEVUE, NE.

REVISIONS
SEPTEMBER 15, 2023
PROJECT #: 23-01

STAIR SECTION AND DETAILS

PENDER PUBLIC SCHOOLS
SPORTS COMPLEX BUILDING
PENDER, NEBRASKA

**PETERS & ASSOCIATES
ARCHITECTS, P.C.**
1103 GALVIN ROAD SOUTH, SUITE 6000
BELLEVUE, NEBRASKA 68005
PHONE: 402-885-8582

**FOR
REVIEW
ONLY**
NOT FOR
CONSTRUCTION

A-4.1

9/15/2023 1:01:14 AM BIM 360://23-01/PSP - Sports Complex Building/SPS-SportsComplex/Modelwork.rvt

Door Schedule

DOOR NO.	DOOR SIZE			DOOR		FRAME		DETAIL NUMBER			RATING	HDWR. NO	FUNCTION	COMMENTS
	W	H	T	TYPE	MATL	TYPE	MATL	HEAD	JAMB	SILL				
101A	4'-0"	T'-0"	1 3/4"	1	HM	1	RF					1	PANIC	
101B	4'-0"	T'-0"	1 3/4"	1	HM	1	RF					1B	PANIC	
101C	4'-0"	T'-0"	1 3/4"	1	HM	1	RF					1	PANIC	
101D	4'-0"	T'-0"	1 3/4"	1	HM	1	RF					1B	PANIC	
102	3'-0"	T'-0"	1 3/4"	1	HM	1	RF	2-A/A-TX	2-C/A-TX	2-B/A-TX		3	CLASSROOM	
103	3'-0"	T'-0"	1 3/4"	2	WD	2	RF	2A/A-TX	2-C/A-TX	2-B/A-TX		6	PUSH/PULL	
104	3'-0"	T'-0"	1 3/4"	2	WD	2	RF	2-A/A-TX	2-C/A-TX	2-B/A-TX		5	OFFICE	
105	3'-0"	T'-0"	1 3/4"	2	WD	2	RF	2-A/A-TX	2-C/A-TX	2-B/A-TX		6	PUSH/PULL	
106	3'-0"	T'-0"	1 3/4"	2	WD	2	RF	2-A/A-TX	2-C/A-TX	2-B/A-TX		4	STORAGE	
109	3'-0"	T'-0"	1 3/4"	1	HM	1	RF	2-A/A-TX	2-C/A-TX	2-B/A-TX		3	CLASSROOM	
112	3'-0"	T'-0"	1 3/4"	1	HM	3	RF					2	STORAGE	PAIR OF DOORS. SECOND LEAF TO HAVE A SLIDE BOLT TOP AND BOTTOM.
113	3'-0"	T'-0"	1 3/4"	1	HM	1	RF					1A	STORAGE	
201	6'-3"	6'-9 1/2"	0"	3	WD	3	WD					7	CLASSROOM	DOOR IS 3'-0" WIDE WITH FIXED PANEL

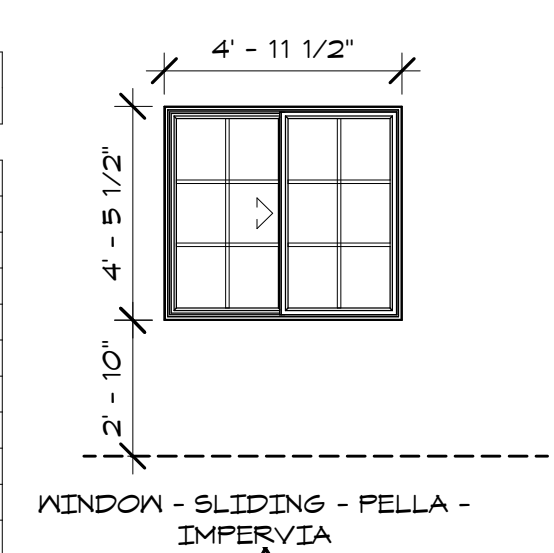

Window Types
1/4" = 1'-0"

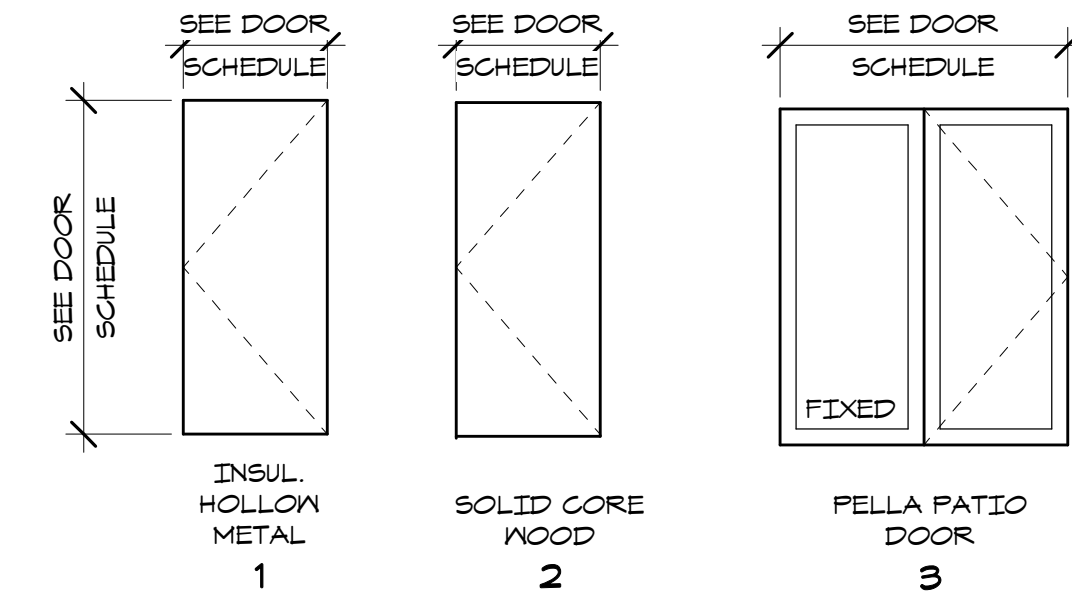

Door Types
1/4" = 1'-0"

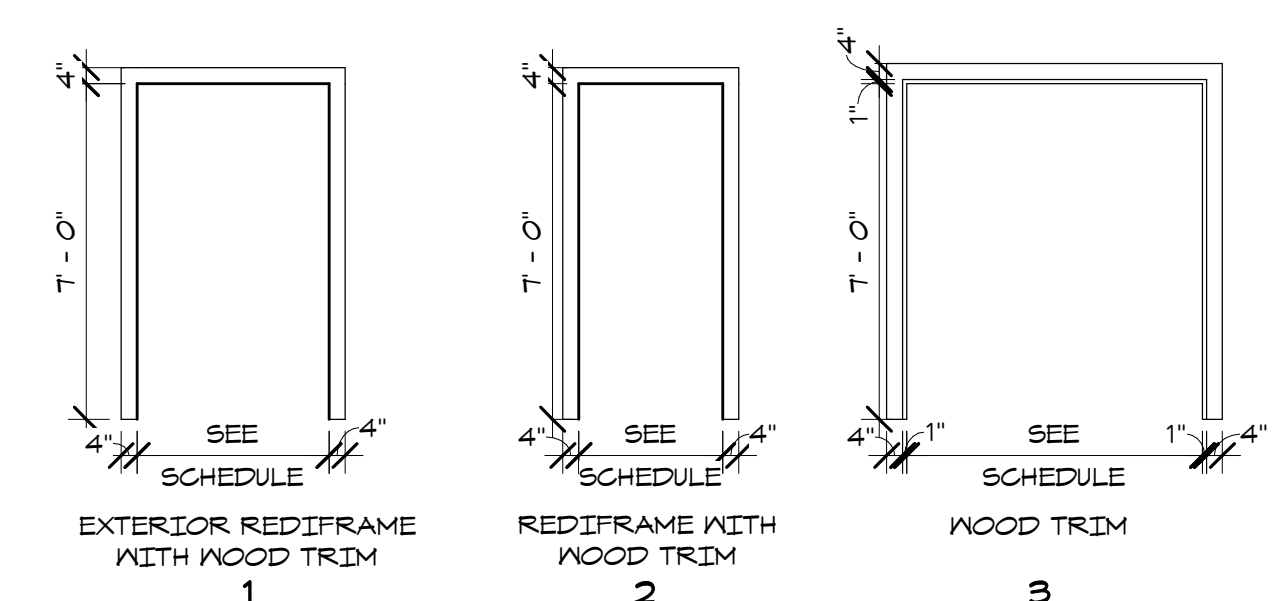

Frame Types
1/4" = 1'-0"

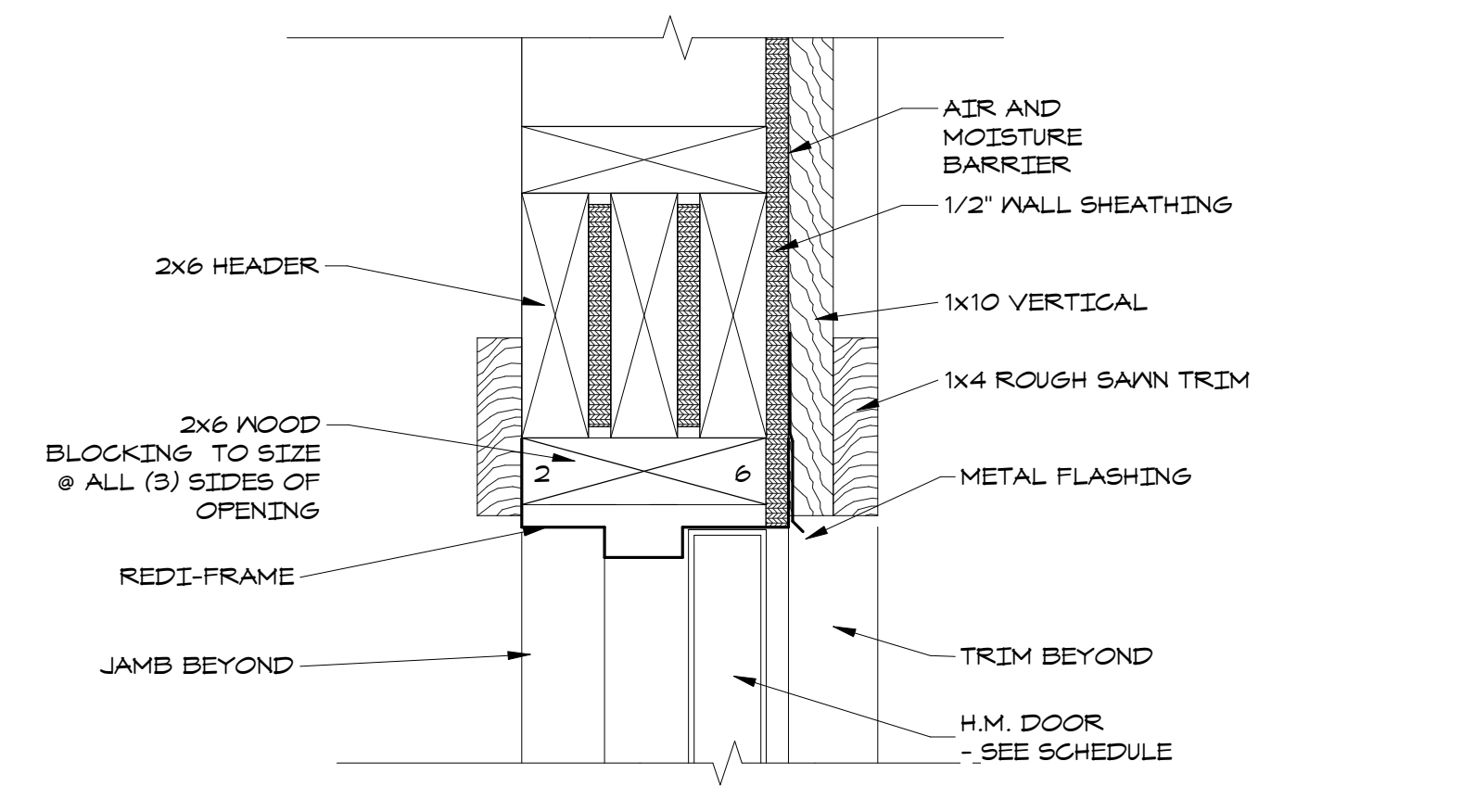

A. HEAD DETAIL
JAMB SIM.

3 Exterior Redi-Frame Door Head @ Non Insul. Wall
3" = 1'-0"

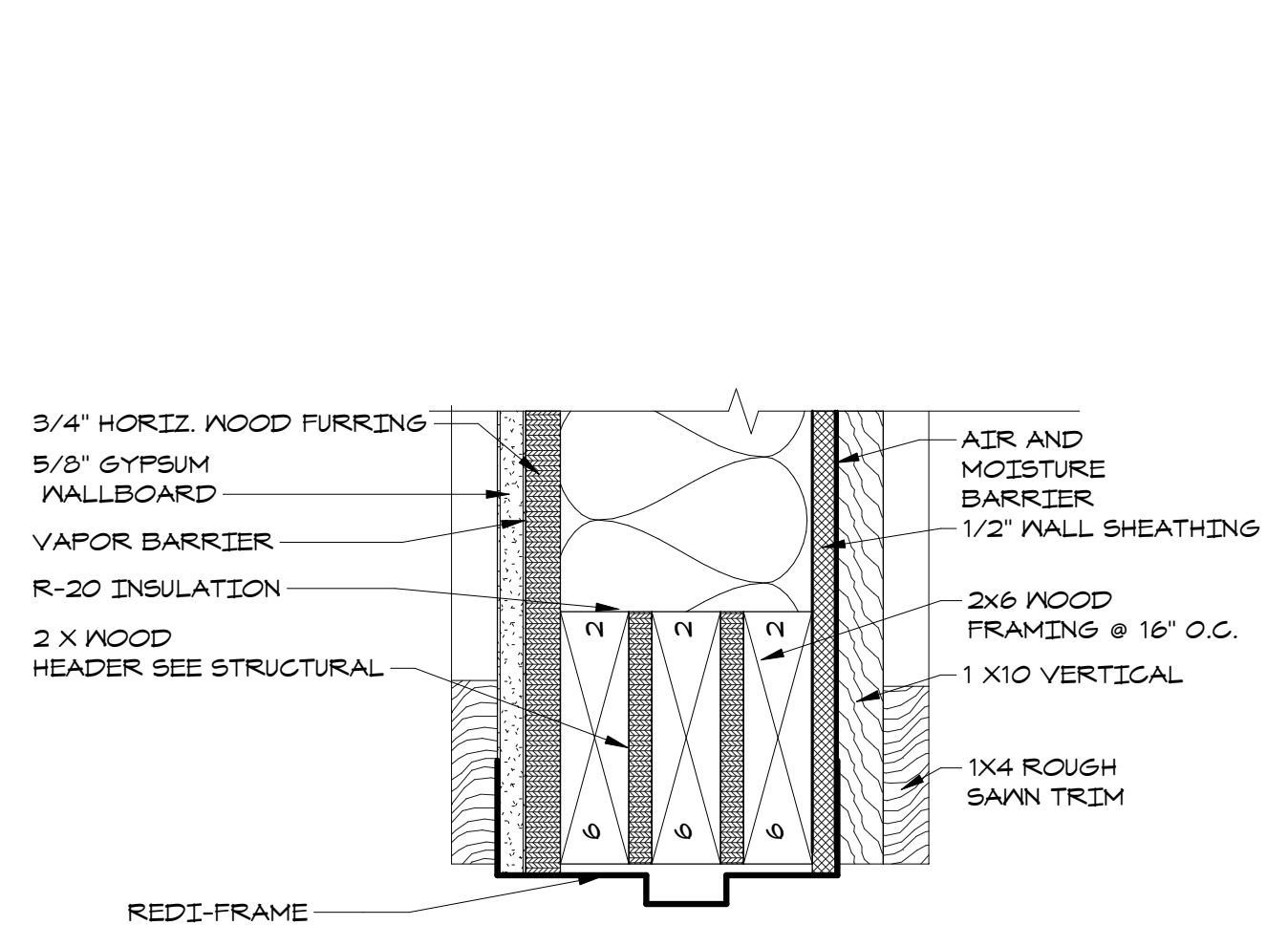

4 Redi-Frame Detail - Exterior
3" = 1'-0"

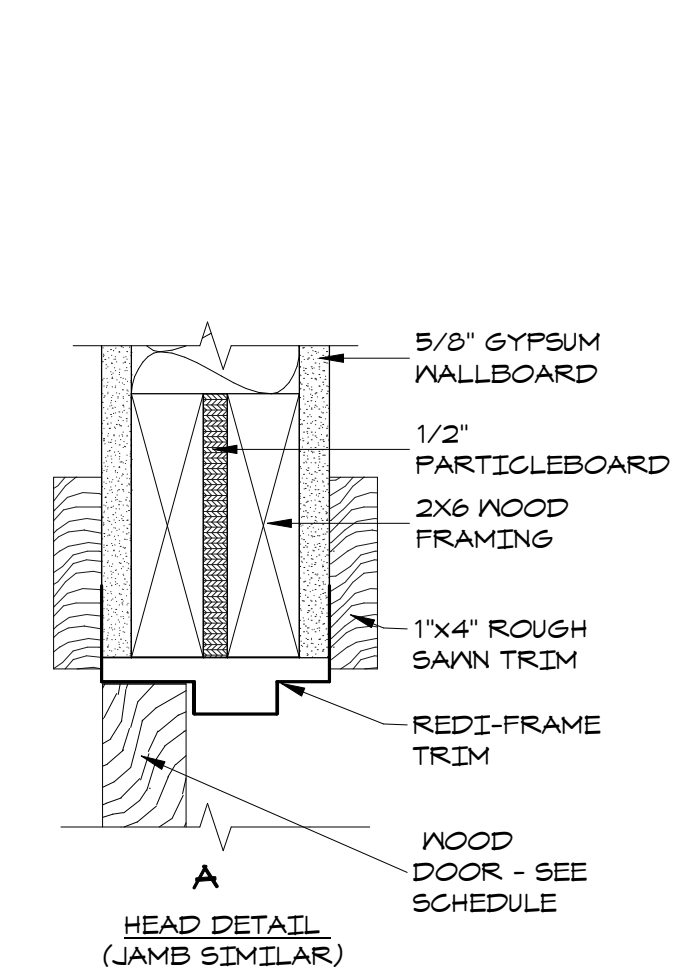

5 Redi-Frame Detail - Interior
3" = 1'-0"

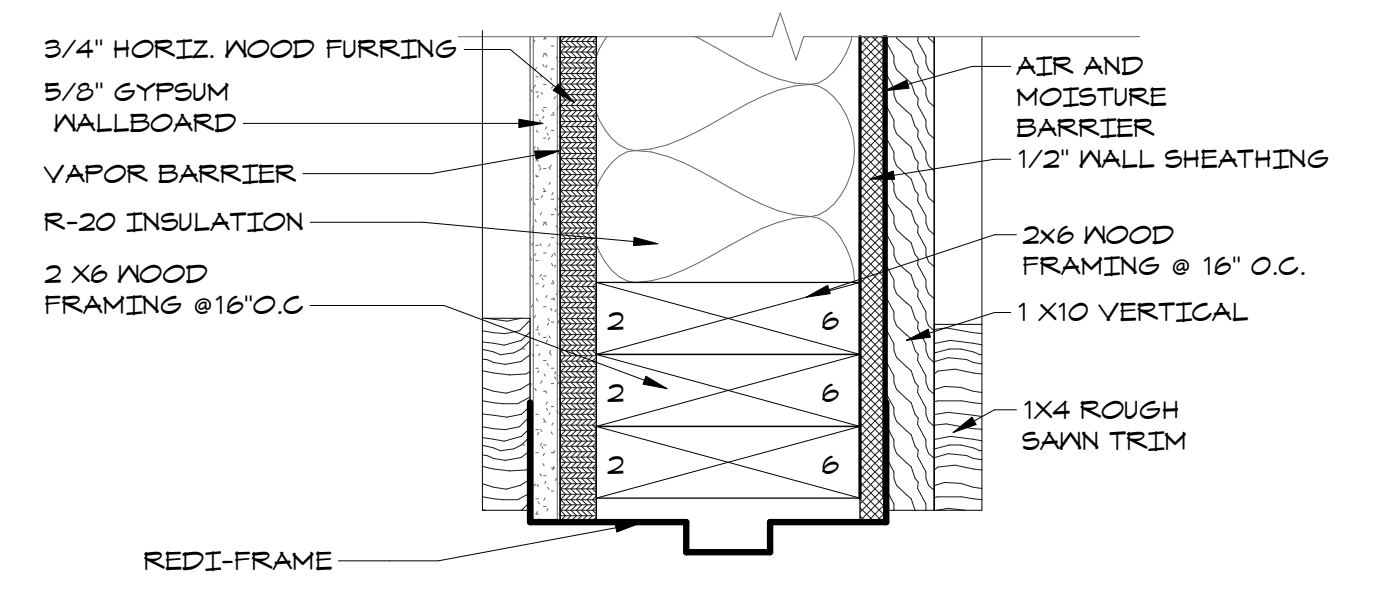
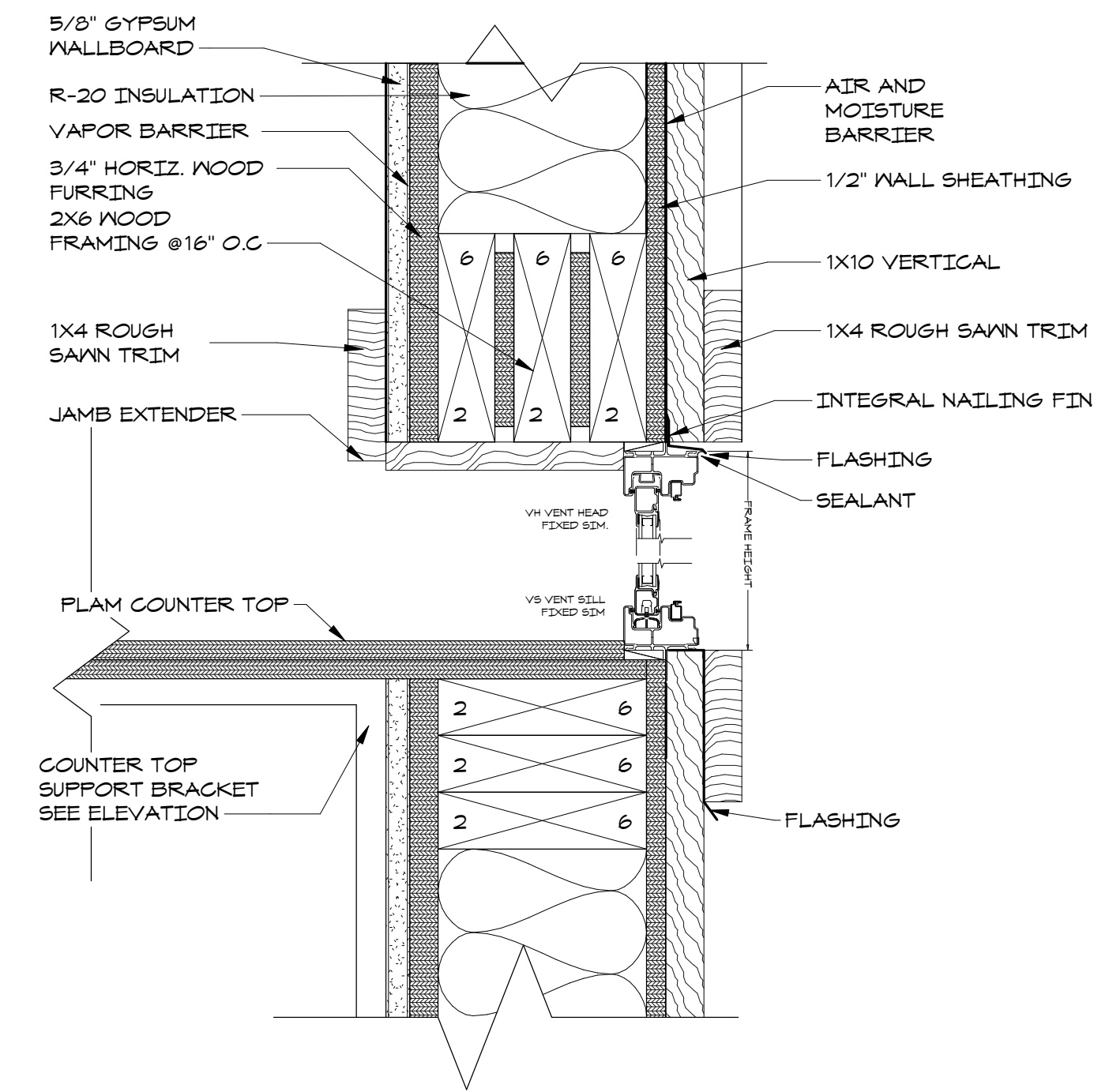

6 Exterior Redi-Frame Door Jamb
3" = 1'-0"

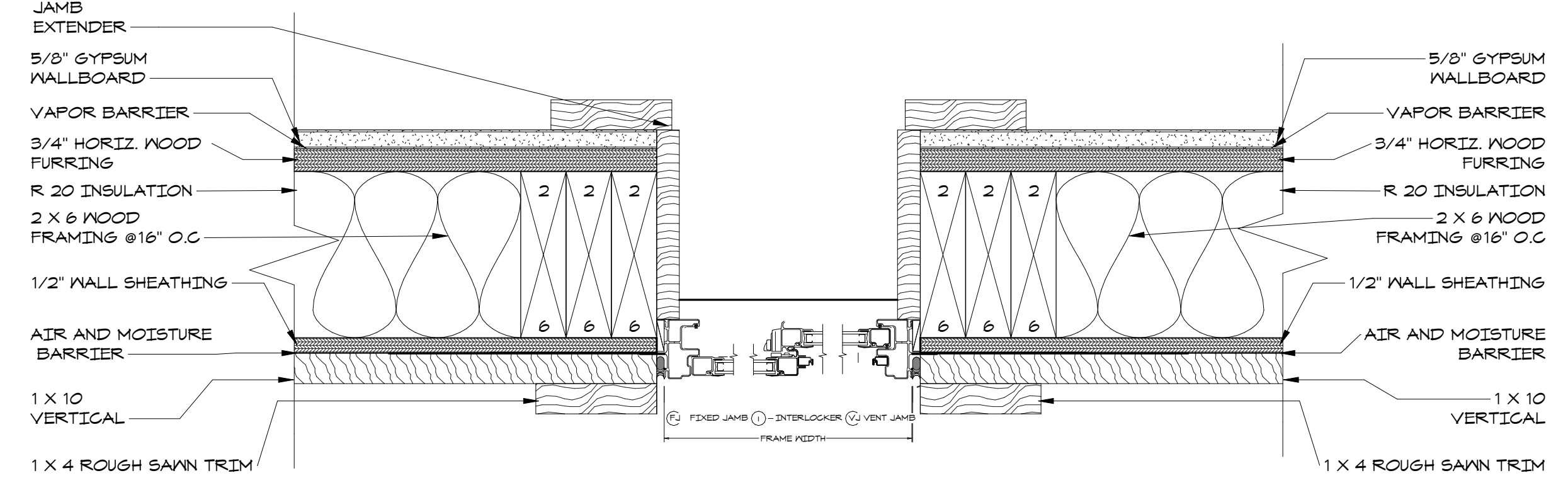

7 Window Details- Sill, Jamb, Head
3" = 1'-0"

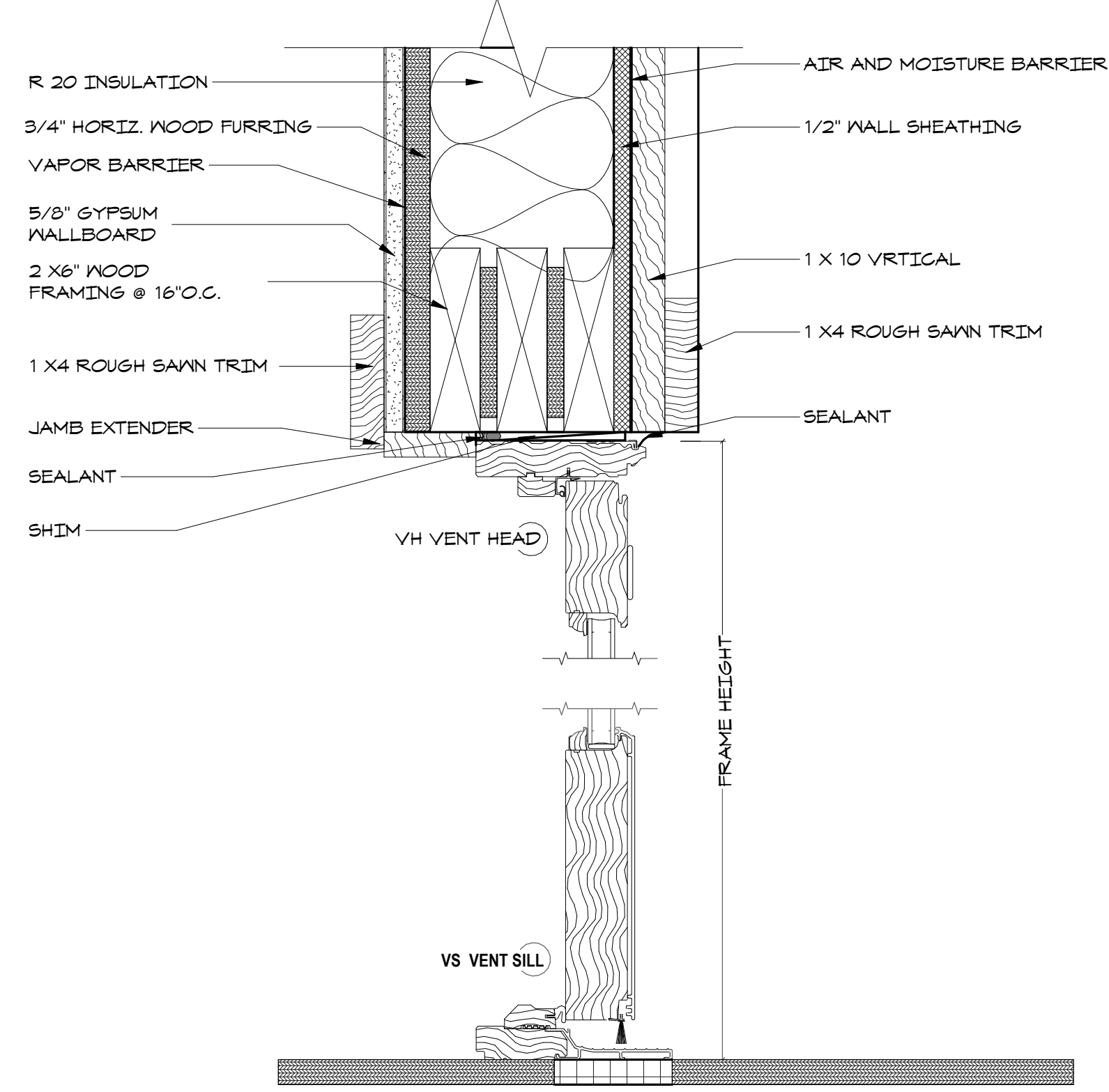

8 Patio Door Sill and Head
3" = 1'-0"

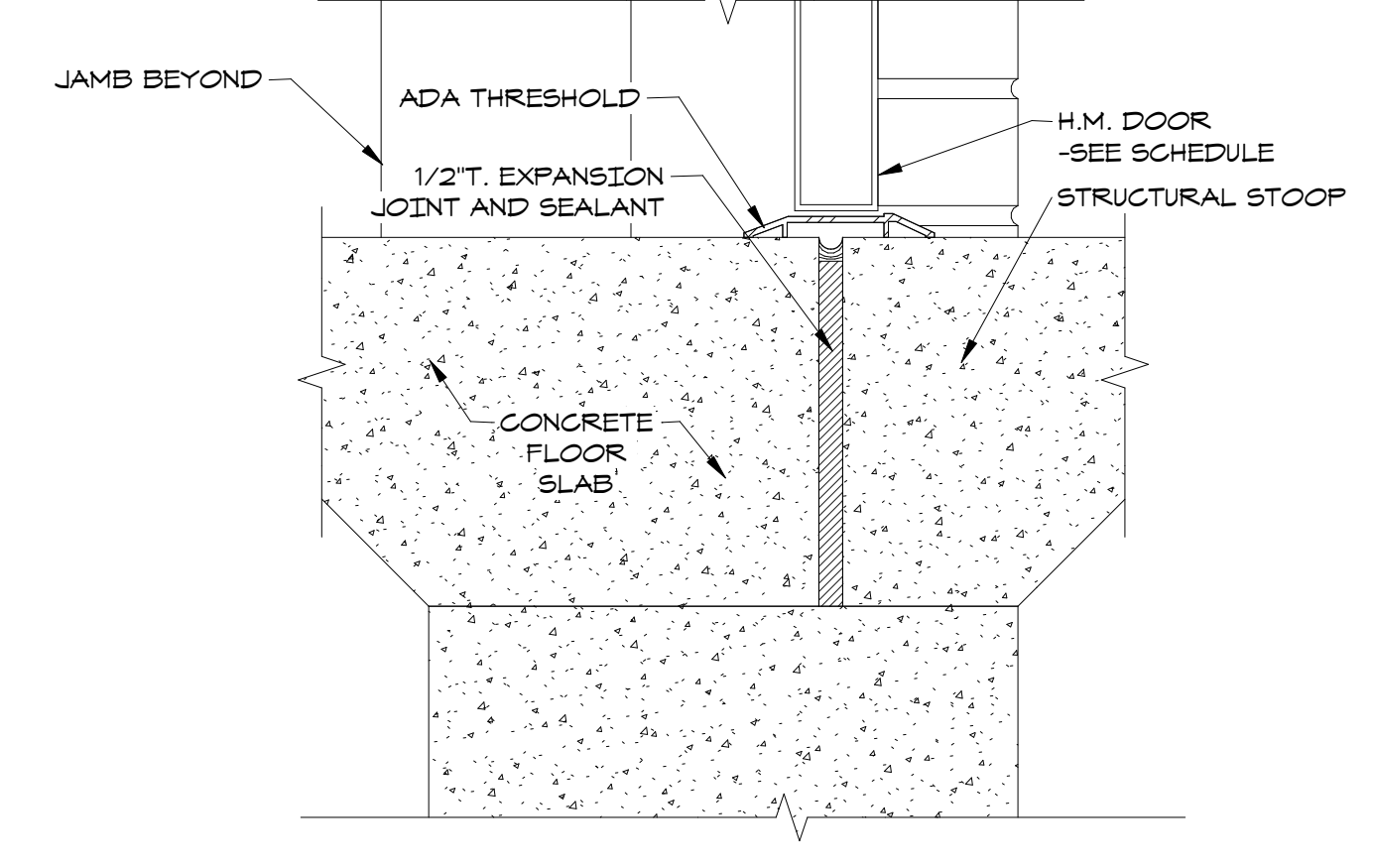

9 Exterior Redi-Frame Sill
3" = 1'-0"

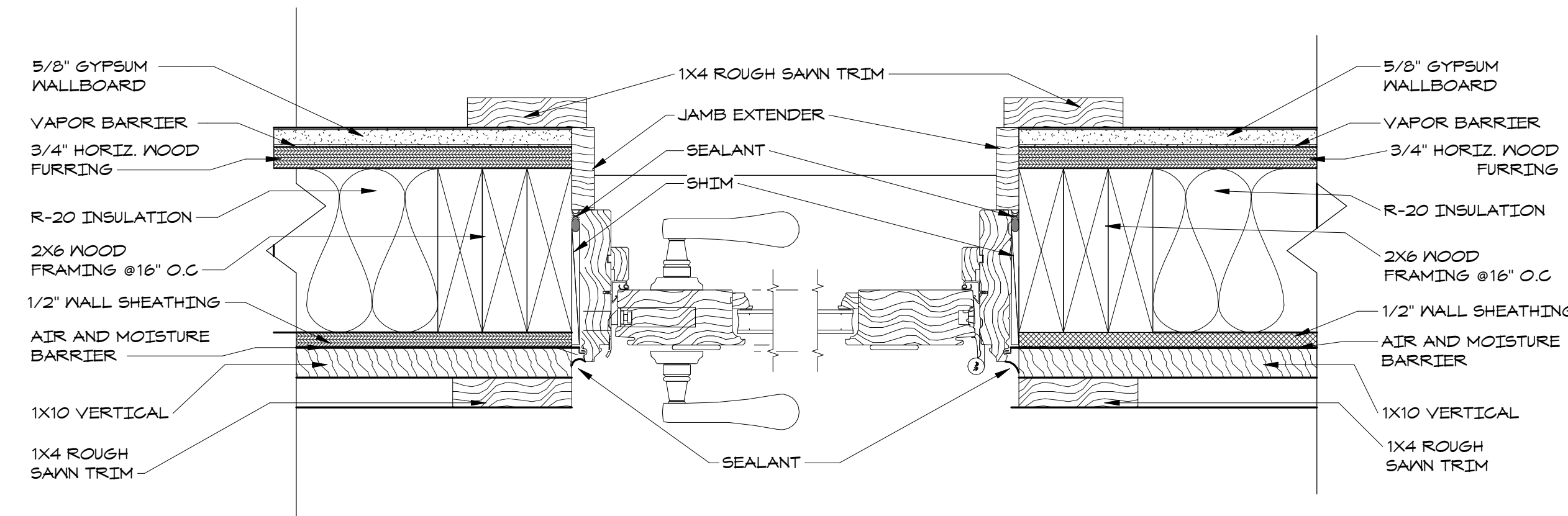

10 Patio Door Jamb
3" = 1'-0"

B. SILL DETAIL

COPYRIGHT 2023
PETERS AND ASSOCIATES ARCHITECTS P.C.
THESE DOCUMENTS ARE ISSUED BY PETERS
AND ASSOCIATES ARCHITECTS P.C. AND ARE
PROTECTED BY COPYRIGHT LAW. THEY MAY
NOT BE REPRODUCED OR DUPLICATED IN
WHOLE OR IN PART WITHOUT EXPRESS
WRITTEN PERMISSION OF PETERS AND
ASSOCIATES ARCHITECTS P.C., BELLEVUE, NE.

REVISIONS
 SEPTEMBER 15, 2023
 PROJECT #: 23-01
DOOR AND FRAME TYPES, WINDOW TYPES
PENDER PUBLIC SCHOOLS SPORTS COMPLEX BUILDING
 PENDER, NEBRASKA
PETERS & ASSOCIATES ARCHITECTS, P.C.
 1103 GALVIN ROAD SOUTH, SUITE 6000
 BELLEVUE, NEBRASKA 68005
 PHONE: 402-885-8582
FOR REVIEW ONLY
 NOT FOR CONSTRUCTION
A-6.1

9/15/2023 1:04:15 AM E:\30123\09\PPS - Sports Complex Building\PPS_SportsComplex\Mainframe.rvt

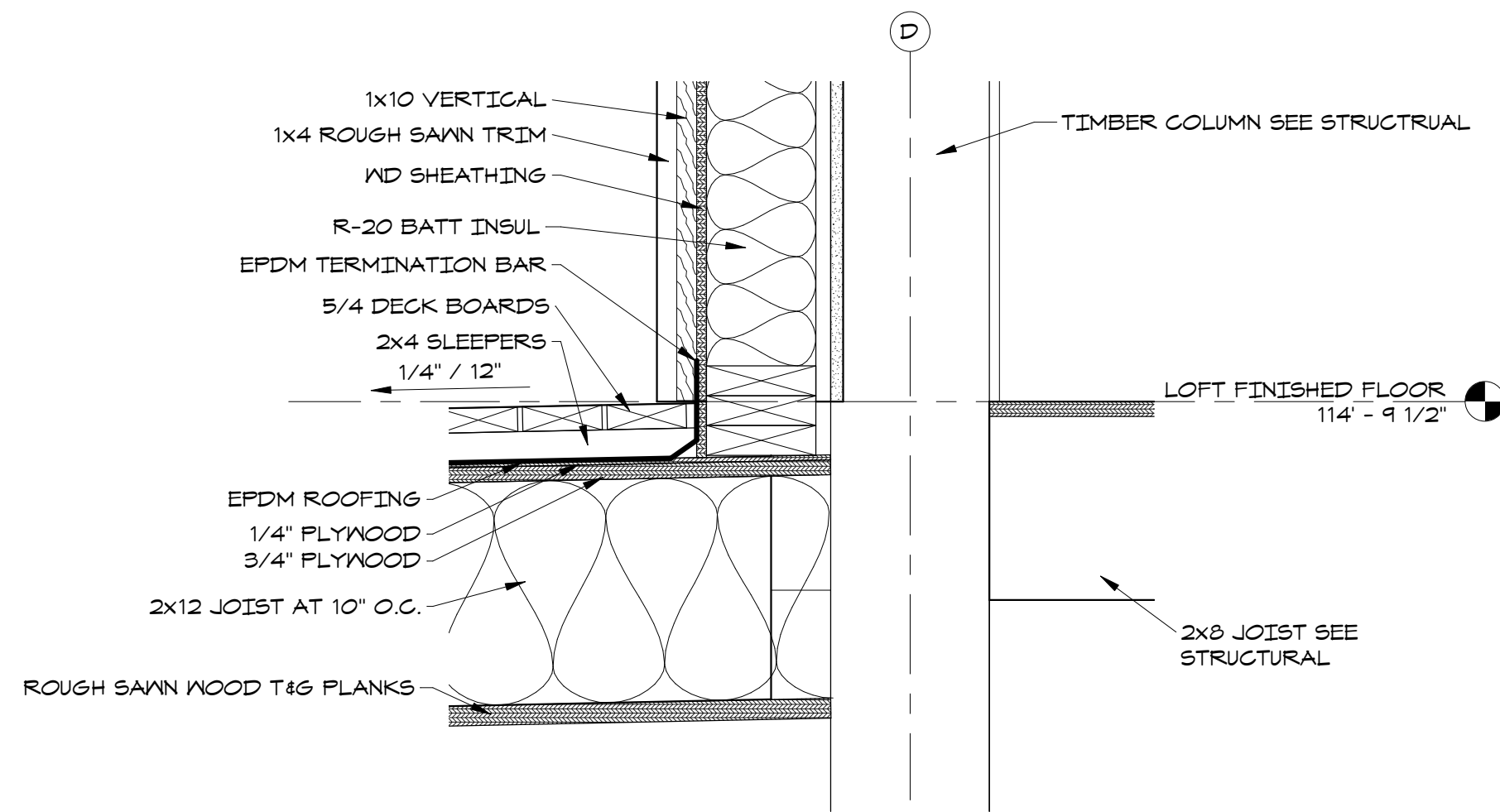

3 Outdoor Balcony/Wall Detail
1 1/2" = 1'-0"

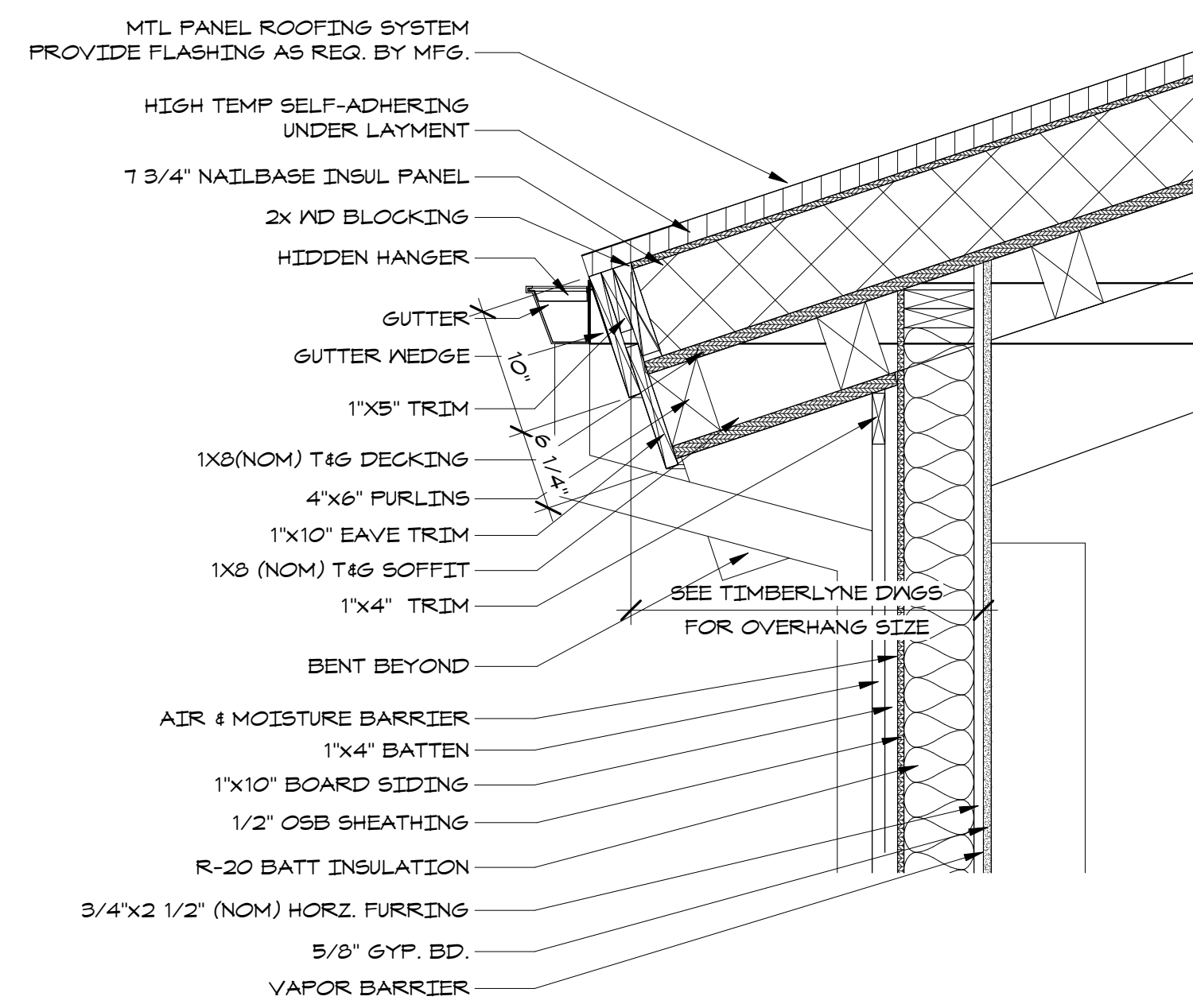

4 Overhang with Gutter Detail
1" = 1'-0"

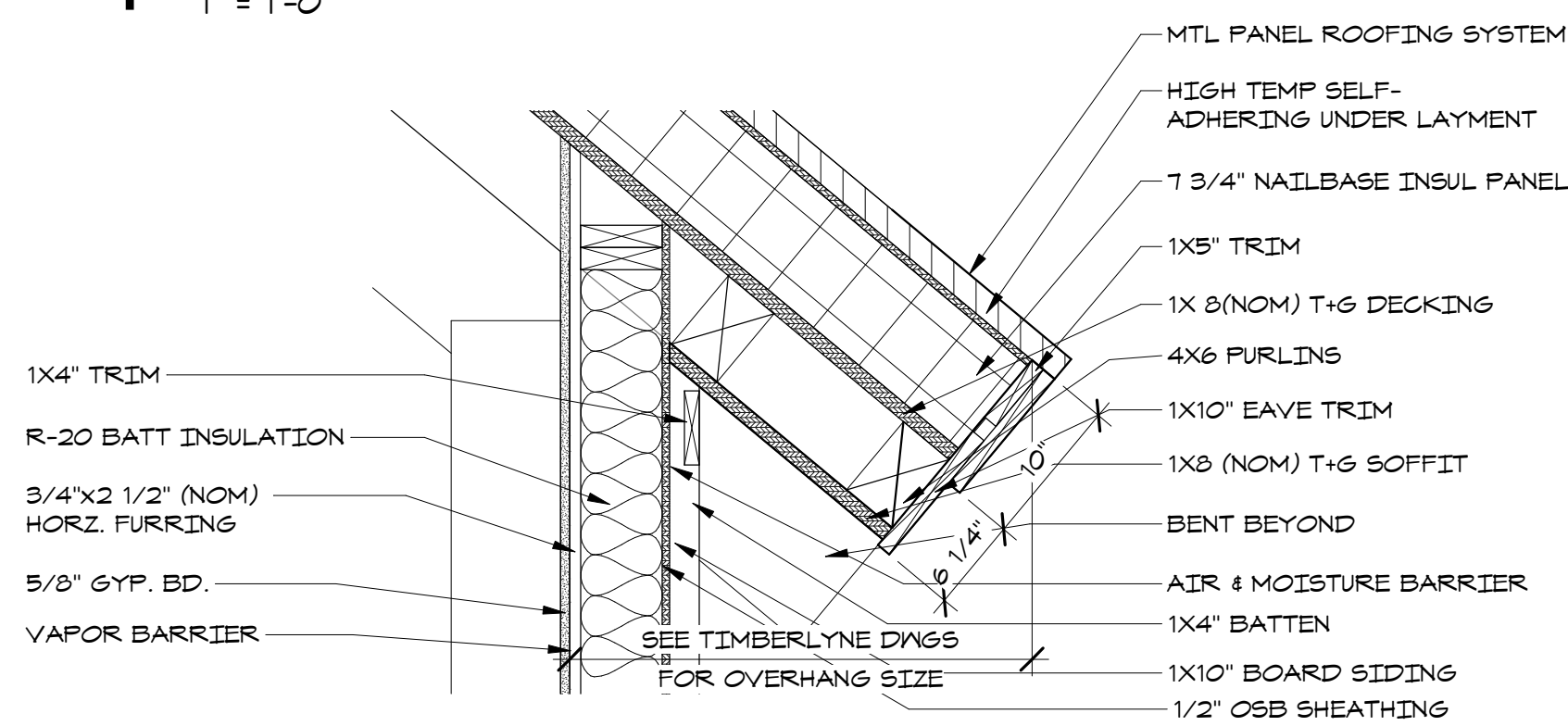

5 Overhang without Gutter Detail
1" = 1'-0"

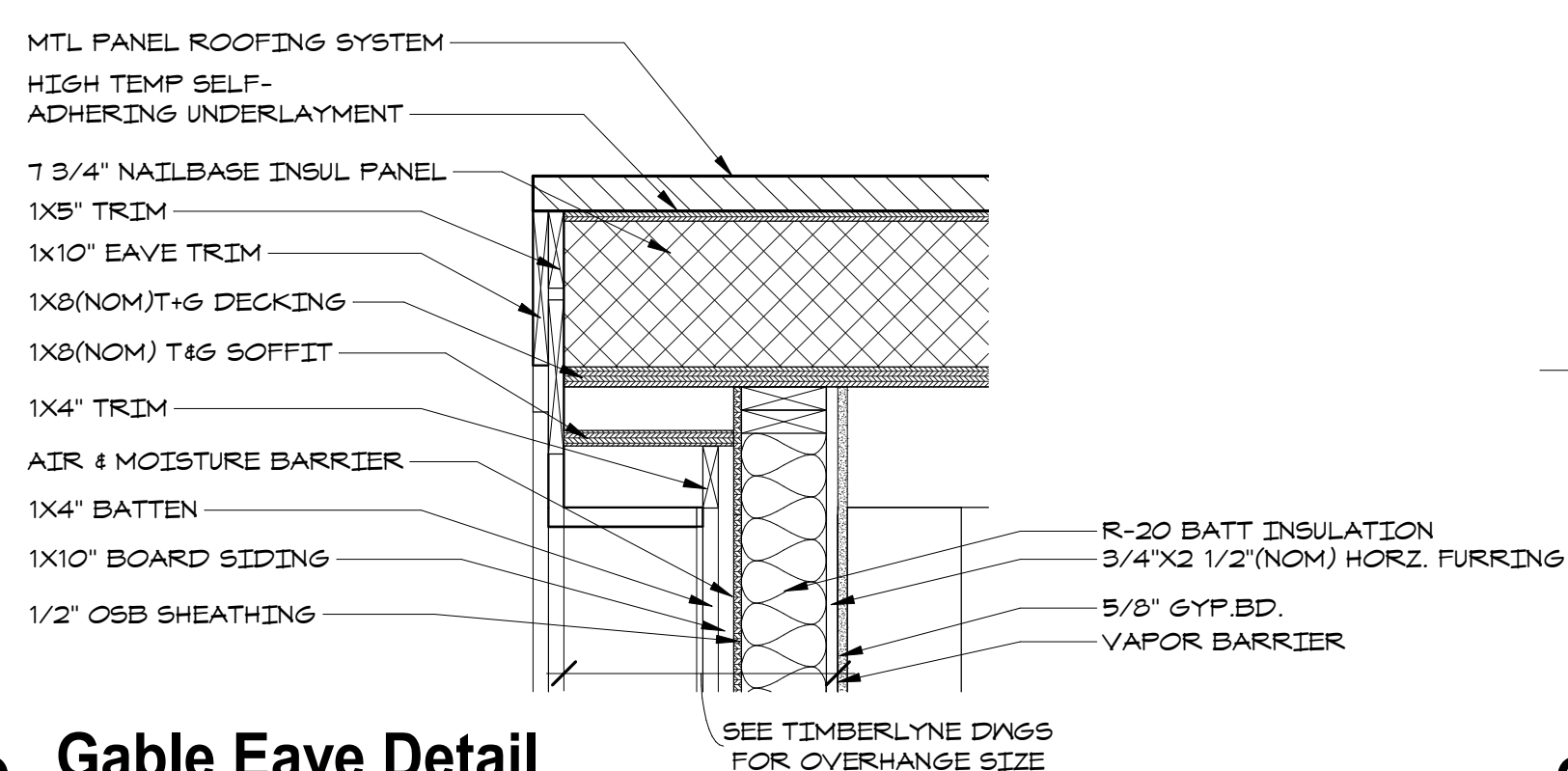

6 Gable Eave Detail
1" = 1'-0"

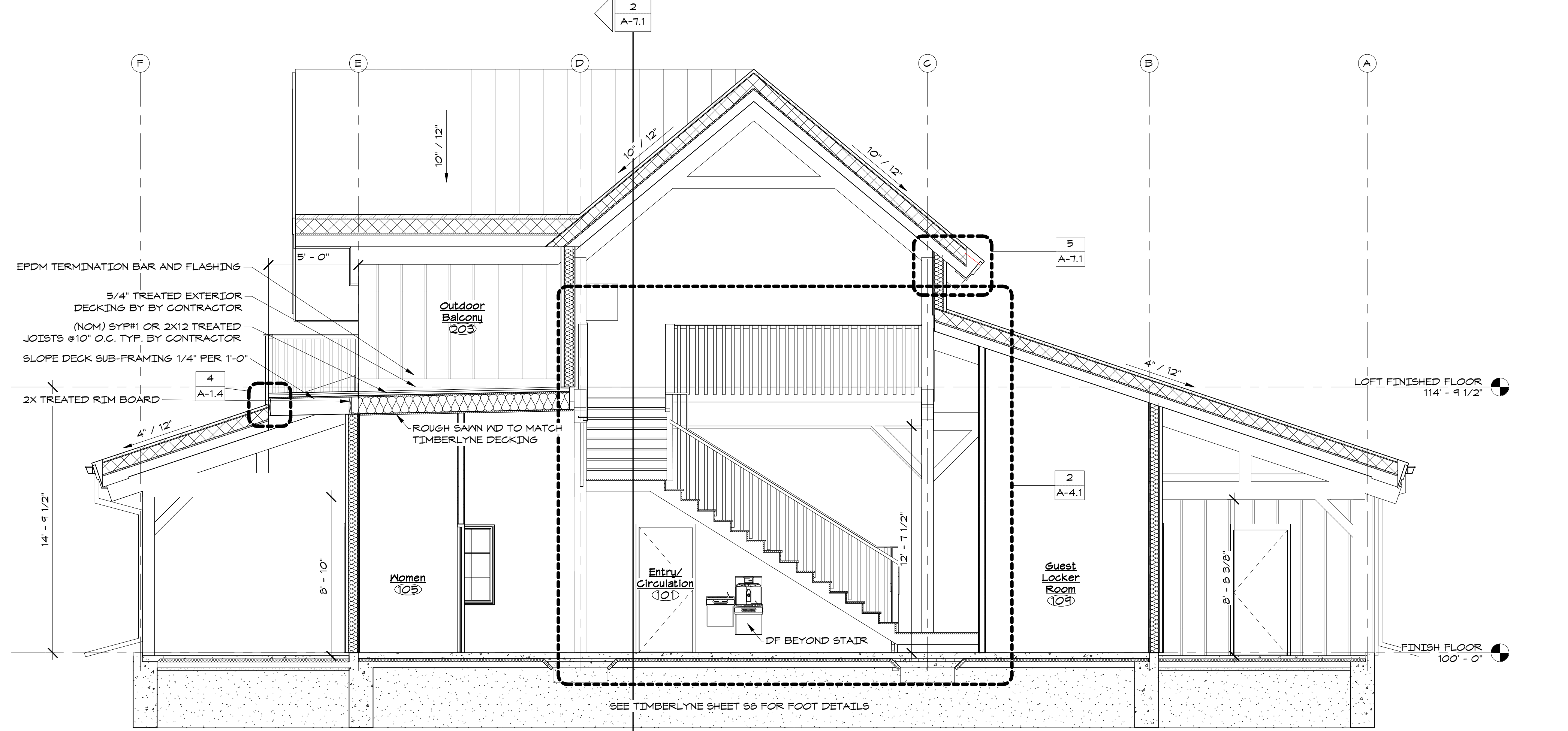

1 Building Section A
1/4" = 1'-0"

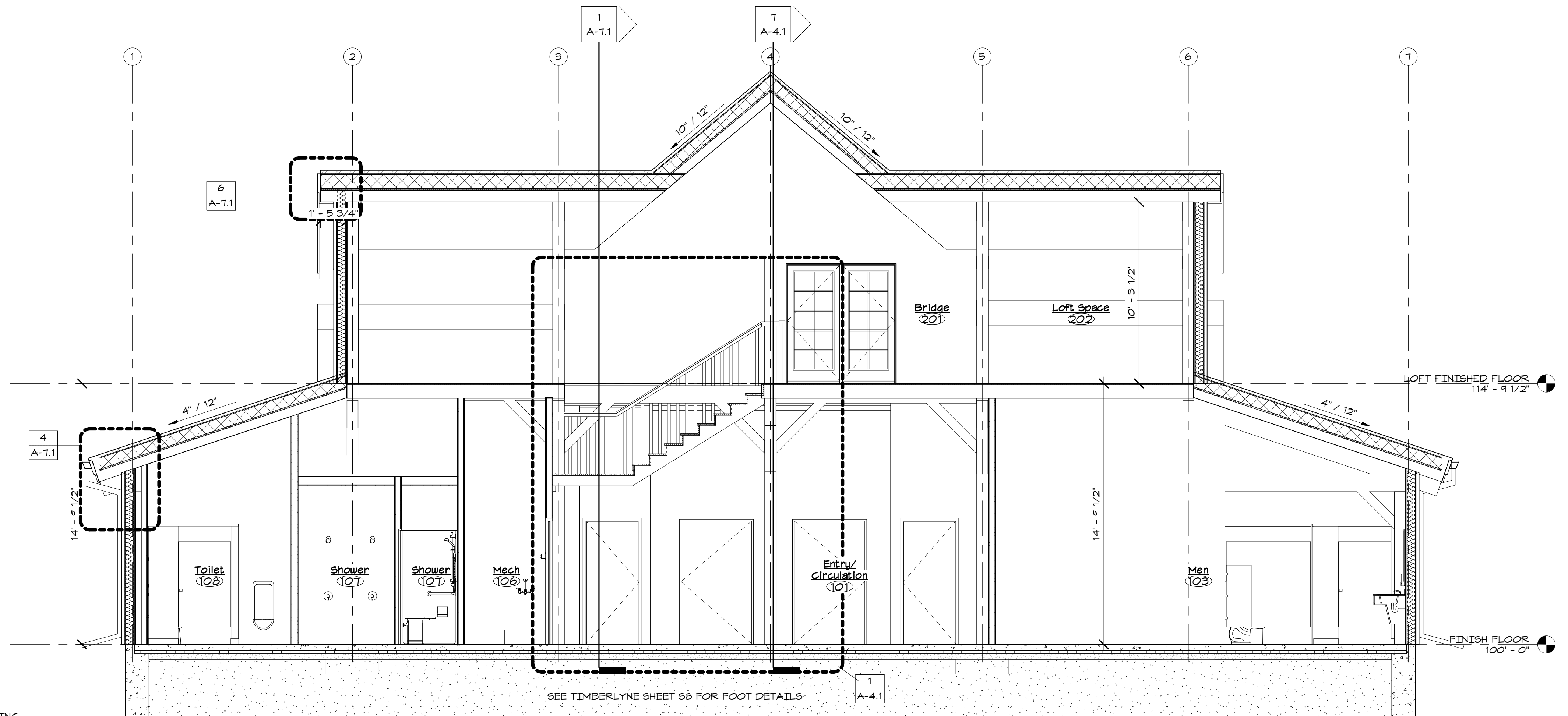

2 Building Section B
1/4" = 1'-0"

COPYRIGHT 2023
PETERS AND ASSOCIATES ARCHITECTS P.C. THESE DOCUMENTS ARE ISSUED BY PETERS AND ASSOCIATES ARCHITECTS P.C. AND ARE PROTECTED BY COPYRIGHT LAW. THEY MAY NOT BE REPRODUCED OR DUPLICATED IN WHOLE OR IN PART WITHOUT EXPRESS WRITTEN PERMISSION OF PETERS AND ASSOCIATES ARCHITECTS P.C., BELLEVUE, NE.

9/15/2023 1:01:19 AM E:\300\23-01\PS - Sports Complex Building\PS - Sports Complex Building\PS - Sports Complex Building.dwg

GENERAL NOTES AND DESIGN SPECIFICATIONS

GENERAL NOTES:

1. EVERY EFFORT HAS BEEN MADE TO ELIMINATE ERRORS DURING THE PREPARATION OF THESE DRAWINGS, BUT BECAUSE SAND CREEK POST & BEAM CANNOT GUARANTEE AGAINST THE POSSIBILITY OF HUMAN ERROR, IT BECOMES THE OBLIGATION OF THE USER TO VERIFY THE ACCURACY OF ALL DETAILS AND DIMENSIONS AND PERSONALLY BE RESPONSIBLE FOR THEM.

2. NOTED DIMENSIONS TAKE PRECEDENCE OVER SCALE. LARGER SCALE OVER SMALLER SCALE.

3. ALL MECHANICAL AND ELECTRICAL PLANS AND SPECIFICATIONS ARE DESIGN/BUILD FURNISHED BY THE MECHANICAL/ELECTRICAL CONTRACTOR FOR THEIR USE.

4. ALL TIMBERS ARE FULL DIMENSION ROUGH SAWN UNLESS NOTED. SILL PLATE IS 2X TREATED UNLESS NOTED OTHERWISE. WE RECOMMEND SILL SEALER BE INSTALLED BENEATH THE SILL PLATE.

5. WHERE FEASIBLE INSTALL THE BOLTS IN THE PLATE JOINERY SO THAT THE NUTS CAN BE ACCESSED FROM THE INTERIOR OF THE BARN. THE SIDING OR FRAMING MAY NEED TO BE NOTCHED SLIGHTLY FOR PLATE AND BOLT CLEARANCE.

6. VERIFY WINDOW AND DOOR ROUGH OPENINGS BEFORE FRAMING.

7. WE RECOMMEND 1/8" BREAKER BOARD BE INSTALLED AT SIDING SPICES. WE RECOMMEND THAT THE CONTRACTOR INSTALL 2 FLASHING @ ALL BREAKER BOARD LOCATIONS.

8. EXTERIOR FLASHING TO BE INSTALLED AT ALL CONNECTIONS BETWEEN ROOFS, WALLS, AND PROJECTIONS OR PENETRATIONS AS REQUIRED BY GOOD CONSTRUCTION PRACTICES. FLASHING IS NOT SUPPLIED BY SAND CREEK POST & BEAM.

9. ANY MATERIALS SHOWN ON THESE DRAWINGS WHICH ARE NOT WRITTEN IN YOUR CONTRACT OR INCLUDED IN THE SAND CREEK POST & BEAM MATERIALS LIST ARE TO BE PROVIDED BY THE BUYER.

FOUNDATION NOTES:

1. LOCAL BUILDING CODE SPECIFICATIONS REGARDING WATERPROOFING, DAMPROOFING AND VENTILATION OF FOUNDATION WALLS AND SLABS, TAKE PRECEDENCE OVER THE STANDARD INFORMATION SHOWN IN THESE DRAWINGS. IT IS THE RESPONSIBILITY OF THE BUYER, OR ON SITE FOUNDATION CONTRACTOR TO SATISFY THE LOCAL BUILDING CODE REQUIREMENTS.

SOIL: FOOTINGS ARE DESIGNED TO A MIN. SOIL CAPACITY OF 1500 PSF. (ASSUMED)

SLABS: CONCRETE SLABS SHALL CONFORM TO A 28 DAY STRENGTH OF 3000 PSI AND FOOTINGS TO A STRENGTH OF 3000 PSI.

CODE: 2018 INTERNATIONAL BUILDING CODE

LOADS

GROUND SNOW LOAD: 25 PSF

ROOF LIVE/SNOW LOAD: 21 PSF

LOFT/BALCONY LIVE LOAD: 100 PSF

WIND LOAD: 120 MPH (ULT) "C" EXPOSURE

(3 SECOND GUST)

SEISMIC DESIGN CATEGORY: A

IMPORTANCE CATEGORY: III

BUILDING ERECTION SAFETY NOTES:

THE CONTRACTOR IS RESPONSIBLE FOR IMPLEMENTING JOB SITE SAFETY AND CONSTRUCTION PROCEDURES IN ACCORDANCE WITH NATIONAL, STATE, AND LOCAL SAFETY REQUIREMENTS. THE ADEQUACY AND SAFETY OF ERECTION BRACING, SHORING, AND TEMPORARY SUPPORTS IS THE SOLE RESPONSIBILITY OF THE GENERAL CONTRACTOR.

WOOD TYPE

STRUCTURAL FRAMING: PONDEROSA PINE #2 OR BETTER UNDO

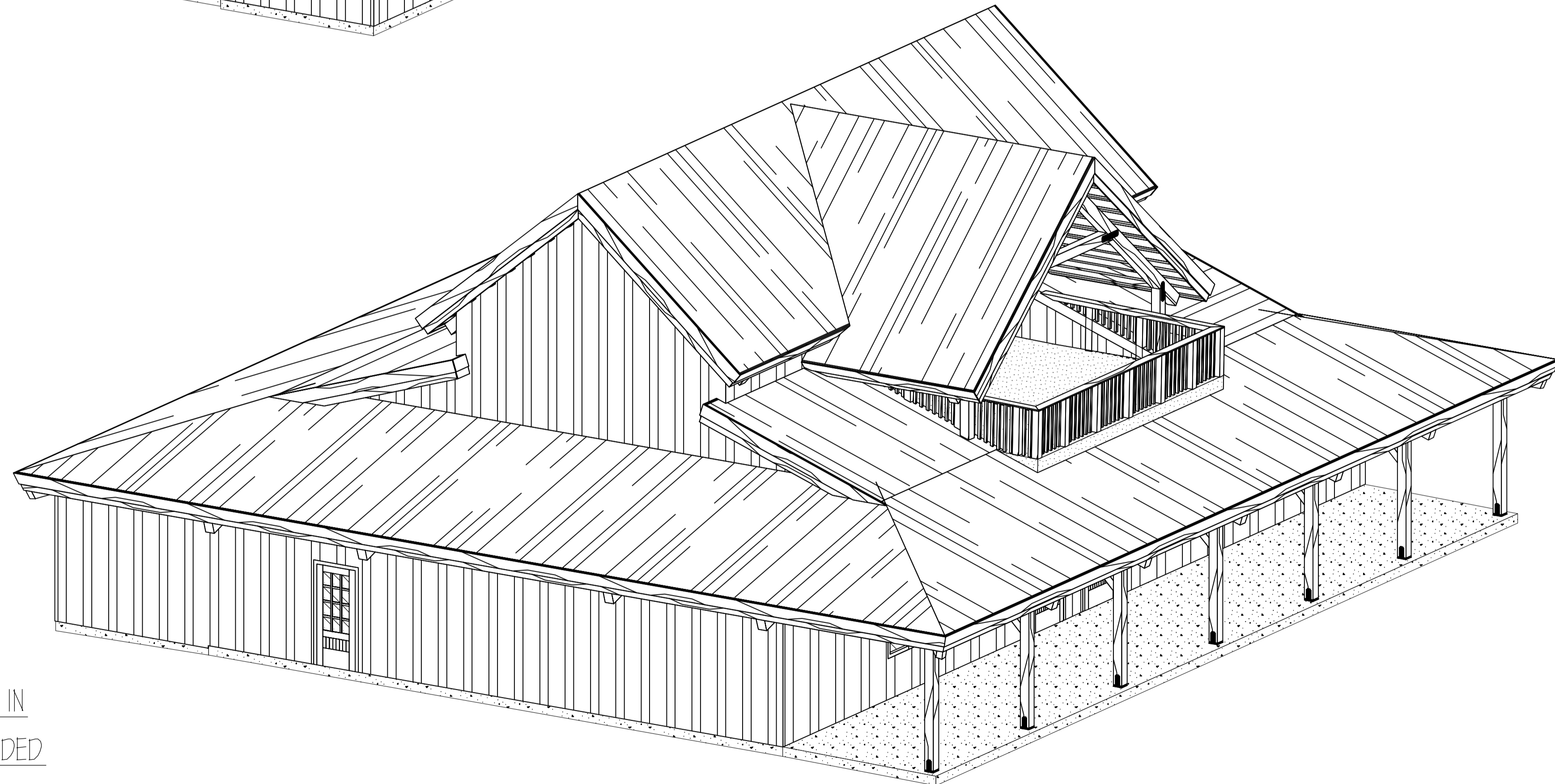
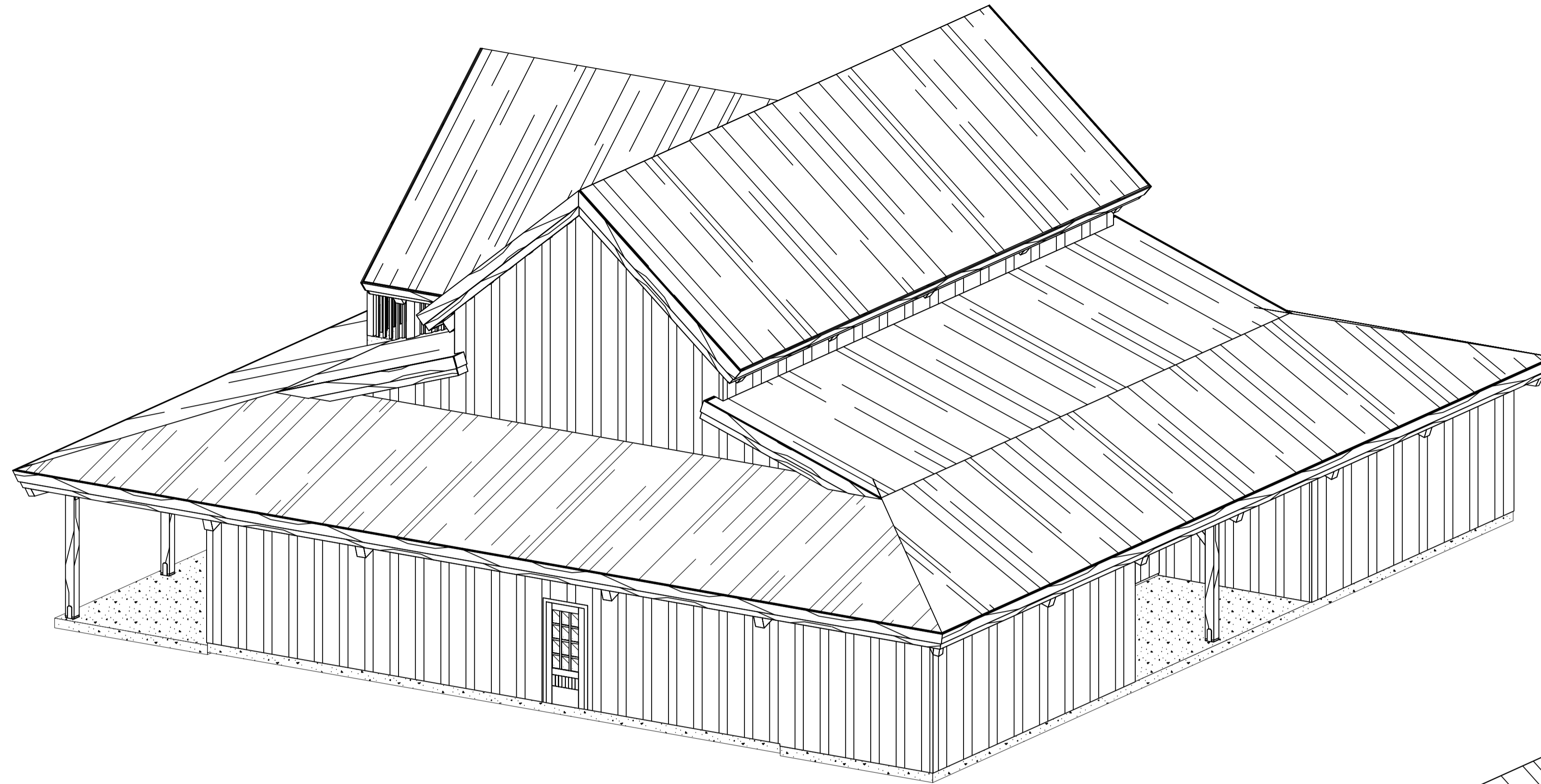

REVISION HISTORY

REV#	DATE	DESCRIPTION
1.0	12/14/2022	FINAL PLAN SET
2.0	02/14/2023	ENG UPGRADES
2.1	08/09/2023	WALL/ROOF UPGRADE / FLOOR PLAN UPDATE
2.2	09/13/2023	LOFT PORCH UPDATE / FOUNDATION UPDATE
		--

SYMBOLS

	WOOD IN SECTION
	CONCRETE IN SECTION
	SAND OR GRAVEL IN SECTION
	STEEL IN SECTION
	BATT INSULATION IN SECTION
	INSULATION NAILBASE IN SECTION
	ARCH ROOF
	BOARD AND BATTEN SIDING

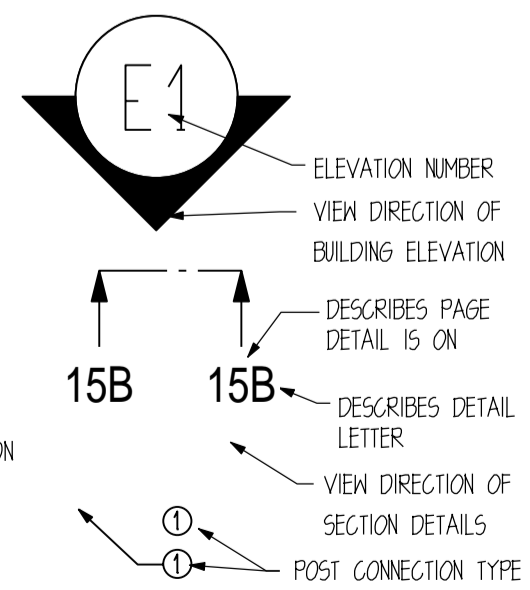

STANDARD ABBREVIATIONS

CONC	CONCRETE	MAX	MAXIMUM	EXT	EXTERIOR
CONT	CONTINUOUS	MIN	MINIMUM	FF	FINISHED FLOOR
DBL	DOUBLE	NTS	NOT TO SCALE	FTG	FOOTING
DF	DOUGLAS FIR	OC	ON CENTER	INSUL	INSULATION
EA	EACH	OH	OVERHEAD	INT	INTERIOR
STD	STANDARD	T&G	TONGUE & GROOVE	TYP	TYPICAL

SHEET INDEX

- COVER SHEET
- EXTERIOR ELEVATIONS
- EXTERIOR ELEVATIONS
- SECTION VIEWS
- MAIN FLOOR LAYOUT
- LOFT FLOOR LAYOUT
- FOUNDATION PLAN
- FOUNDATION DETAILS
- BENT DETAILS
- PLATE JOINERY
- BENT DETAILS
- BENT DETAILS
- BENT FRAME ISO
- BENT LAYOUT
- POST CONNECTIONS
- LOFT FRAMING PLAN
- ROOF FRAMING PLAN
- PRIN LAYOUT
- ROOF FRAME ISO
- BUILDING SECTIONS
- EXTERIOR JOIST AND DECKING
- BUILDING SECTIONS
- EXTERIOR RAILING
- BUILDING SECTIONS
- SIMPSON HANGERS
- ATTACHMENT DETAILS
- DOORS AND WINDOWS UNO
- FLASHING DETAILS
- HOLDINGS
- MAIN SHEAR WALL SCHEDULE
- LOFT SHEAR WALL SCHEDULE

LIST BELOW ARE ITEMS SHOWN IN DRAWINGS BUT ARE NOT PROVIDED BY TIMBERLYNE

- FINISHED ROOFING MATERIAL
- FLASHING MATERIAL
- STAIRS
- EXTERIOR JOIST AND DECKING
- EXTERIOR RAILING
- SIMPSON HANGERS
- DOORS AND WINDOWS UNO
- HOLDINGS
- VERT WALL FRAMING

COVER SHEET

NOTE: LINE 3D DIAGRAMS ON COVER SHEET (SHEET #1) ARE REPRESENTATIONAL ONLY AND ARE NOT INTENDED FOR USE AS CONSTRUCTION DRAWINGS

CUSTOMER INFORMATION:

PENDER
SPORTS COMPLEX

PROJECT INFORMATION:

PENDER
COMPLEX
100 SLAUGHTER
PENDER, NE 68047
NUMBER: JGE1122-1 PSC

CATEGORY: COMMERCIAL

STYLE: GREAT PLAINS WESTERN

OTHER: --

OTHER: --

PM: --

DRAWING INFORMATION:

DRAWN BY: BJ

DATE: 09/13/2023

STATUS: FINAL PLAN SET

OTHER: --

OTHER: --

SHEET NOTES

SHEET

S1

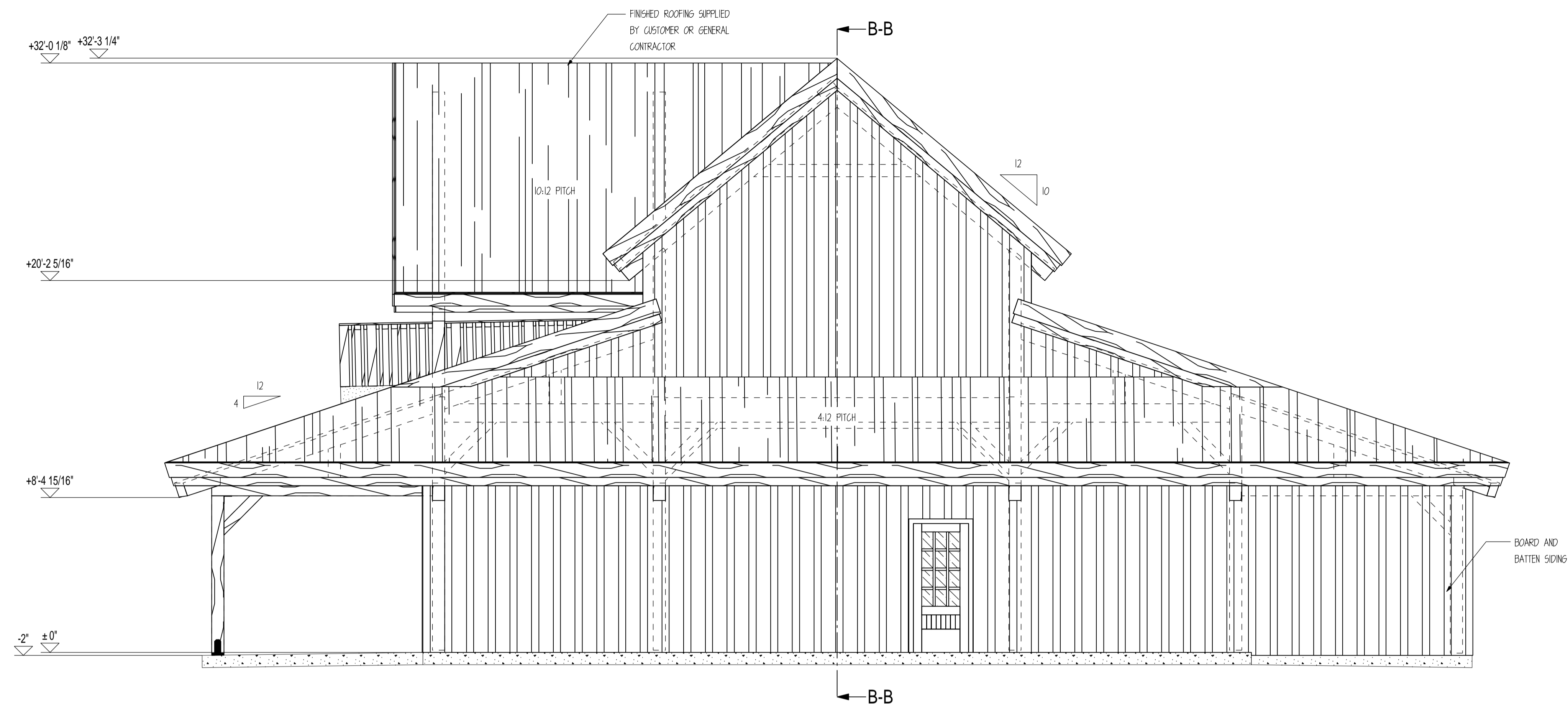

E1 NORTH ELEVATION
SCALE: 1/4" = 1'

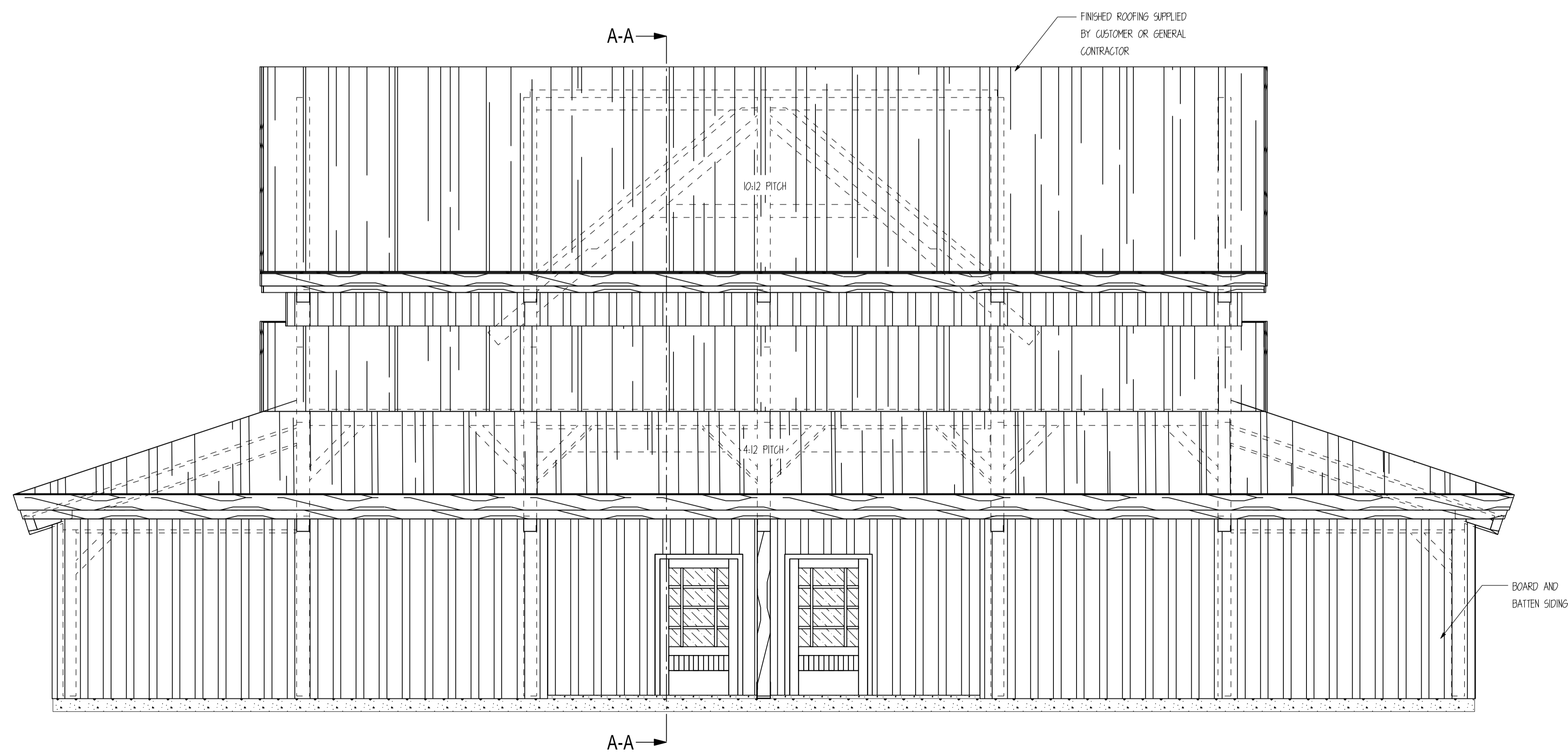

E2 EAST ELEVATION
SCALE: 1/4" = 1'

CUSTOMER INFORMATION:

PENDER
SPORTS COMPLEX

PROJECT INFORMATION:

PENDER
COMPLEX
100 SLAUGHTER
PENDER, NE 68047
NUMBER: JGE1122-1 PSC
CATEGORY: COMMERCIAL
STYLE: GREAT PLAINS WESTERN
OTHER: --
OTHER: --
PM: --

DRAWING INFORMATION:

DRAWN BY: BJ
DATE: 09/13/2023
STATUS: FINAL PLAN SET
OTHER: --
OTHER: --

SHEET NOTES

SHEET NOTES:
1. BREAKER BOARD LOCATION IS APPROX. ONLY AND SHOULD BE INSTALLED ON SITE TO MATCH SIDING LENGTH PROVIDED.
2. DOOR AND WINDOW LOCATIONS ARE APPROX. ONLY. EXACT LOCATIONS TO BE VERIFIED BY CUSTOMER AND GENERAL CONTRACTOR.
3. FINISHED ROOFING MATERIAL TO BE PROVIDED BY CUSTOMER OR GENERAL CONTRACTOR. ROOFING UNDERLAYMENT PROVIDED BY TIMBERLYNE.

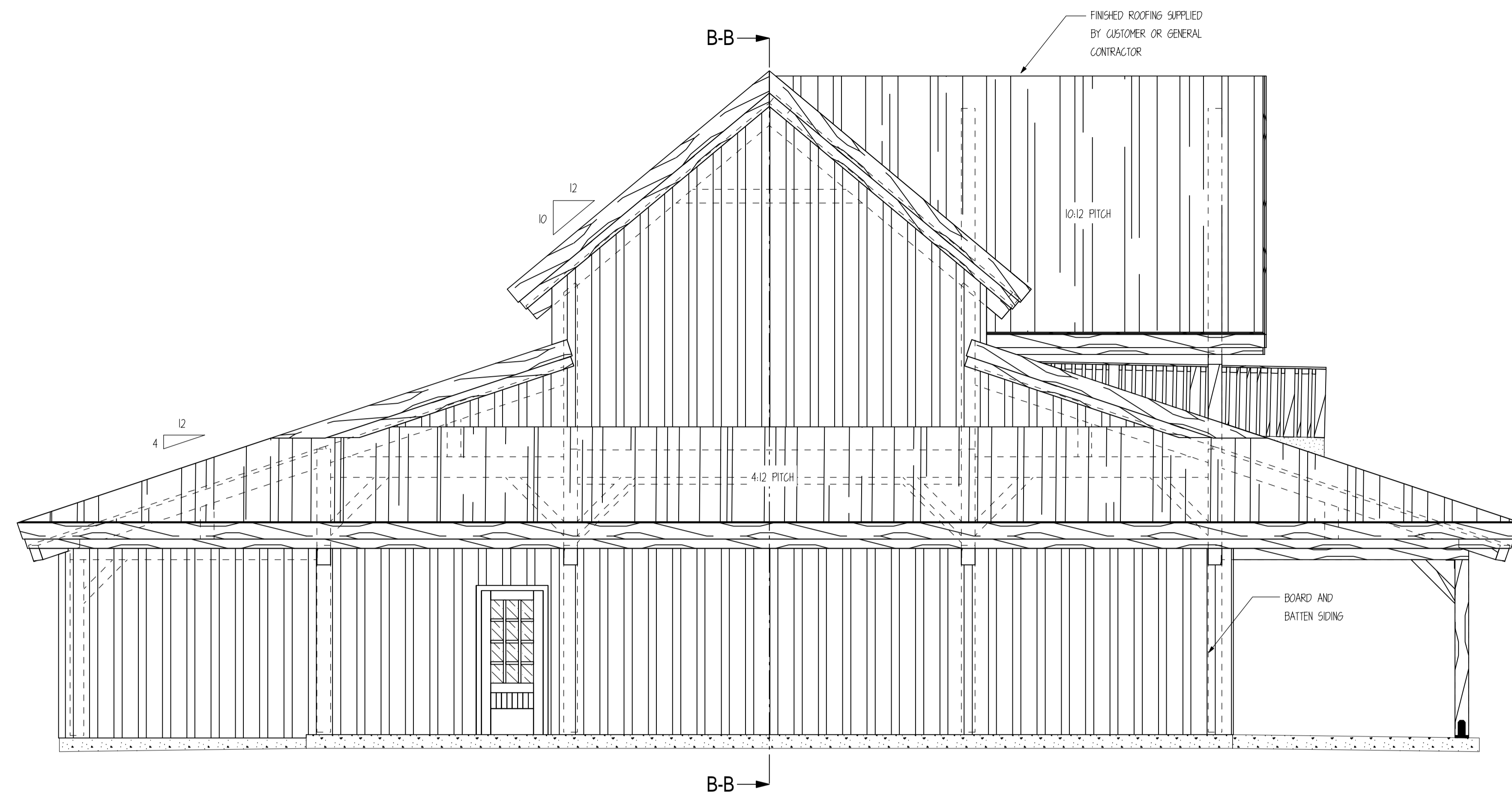

E3 SOUTH ELEVATION
SCALE: 1/4" = 1'

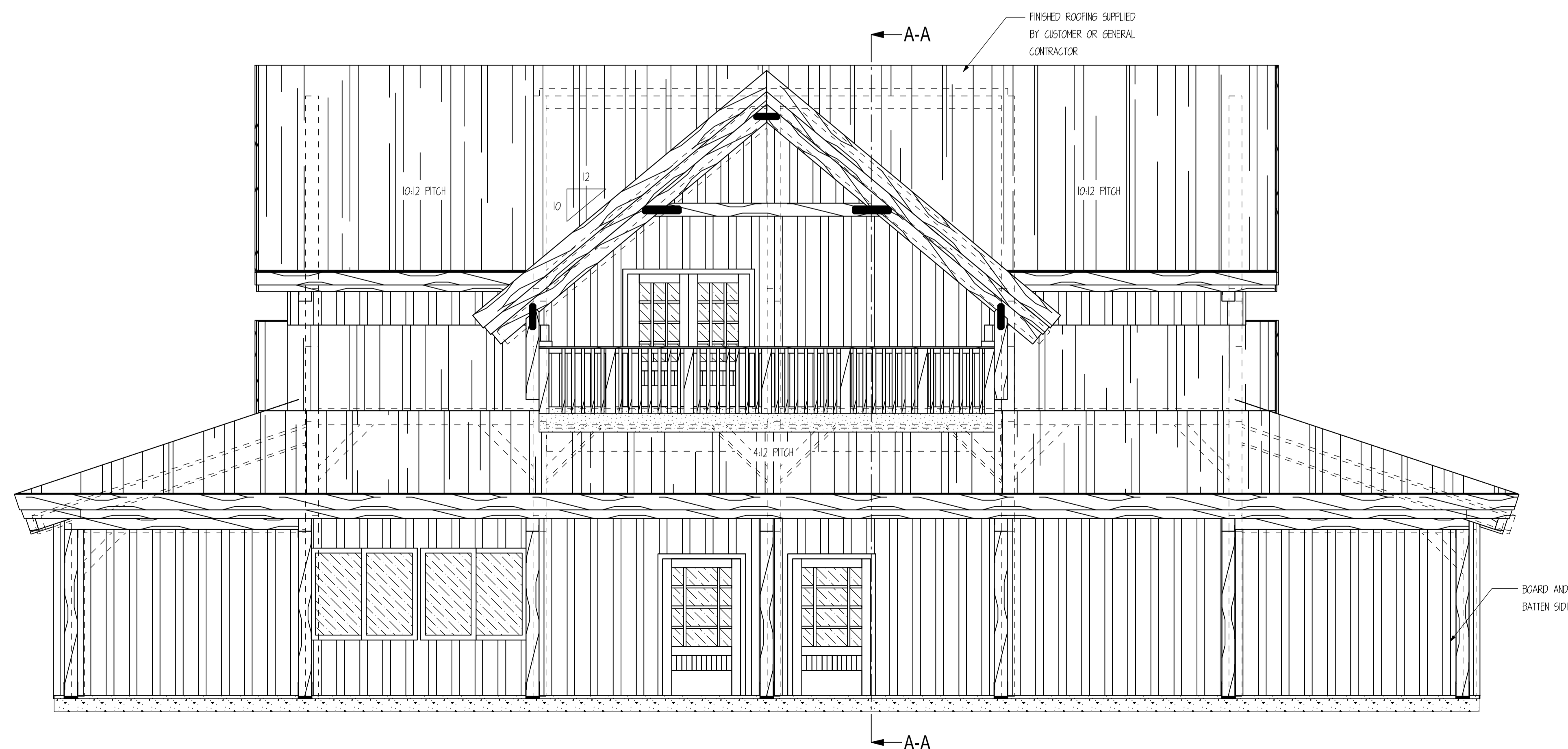

E4 WEST ELEVATION
SCALE: 1/4" = 1'

CUSTOMER INFORMATION:

PENDER
SPORTS COMPLEX

PROJECT INFORMATION:

PENDER
COMPLEX
100 SLAUGHTER
PENDER, NE 68047
NUMBER: JGE1122-1 PSC
CATEGORY: COMMERCIAL
STYLE: GREAT PLAINS WESTERN
OTHER: --
OTHER: --
PM: --

DRAWING INFORMATION:

DRAWN BY: BJ
DATE: 09/13/2023
STATUS: FINAL PLAN SET
OTHER: --
OTHER: --

SHEET NOTES

SHEET

S3

SHEET NOTES:
1. BREAKER BOARD LOCATION IS APPROX. ONLY AND SHOULD BE INSTALLED ON SITE TO MATCH SIDING LENGTH PROVIDED.
2. DOOR AND WINDOW LOCATIONS ARE APPROX. ONLY. EXACT LOCATIONS TO BE VERIFIED BY CUSTOMER AND GENERAL CONTRACTOR.
3. FINISHED ROOFING MATERIAL TO BE PROVIDED BY CUSTOMER OR GENERAL CONTRACTOR. ROOFING UNDERLAYMENT PROVIDED BY TIMBERLYNE.

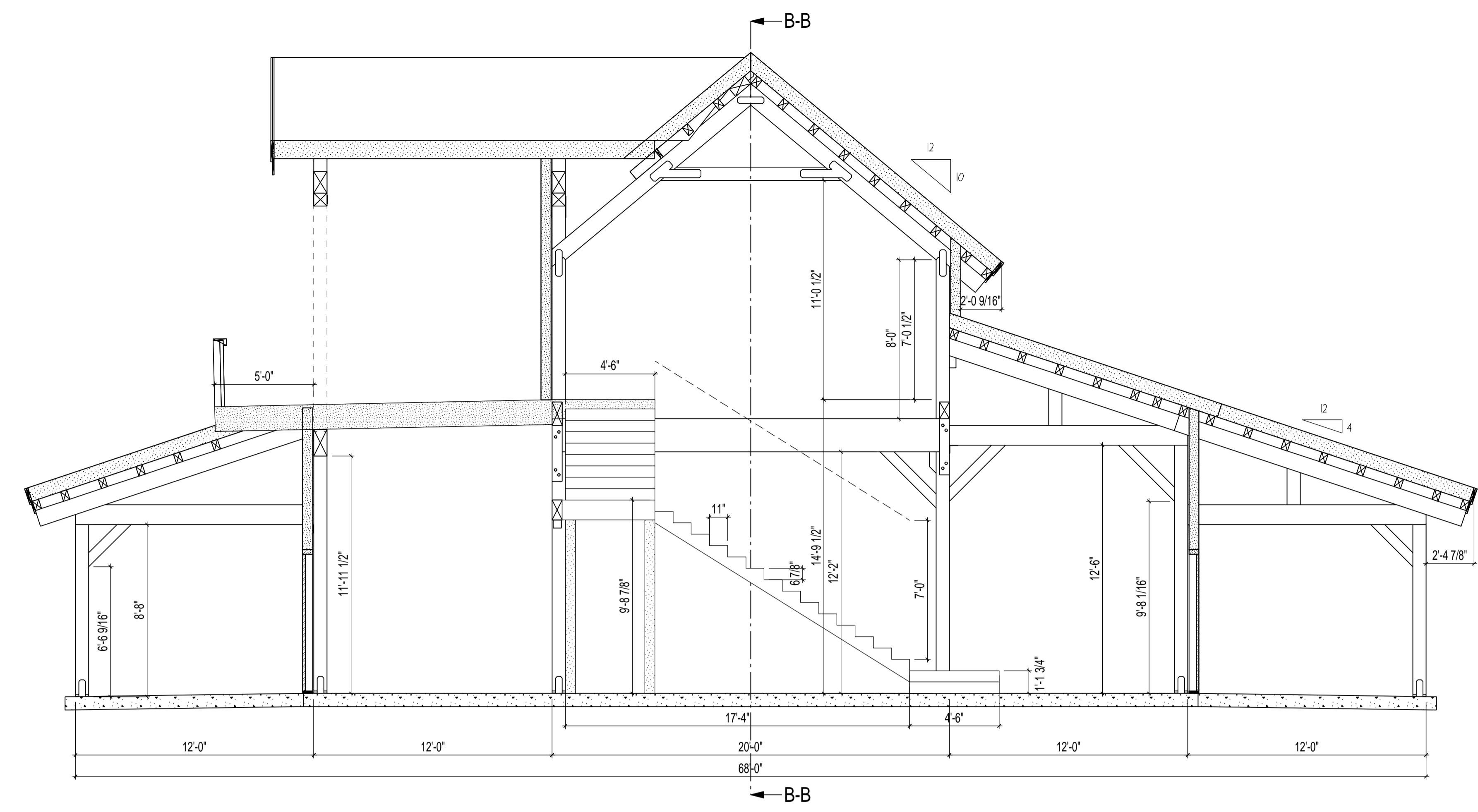

BUILDING SECTION A-A

SCALE: 1/4" = 1'

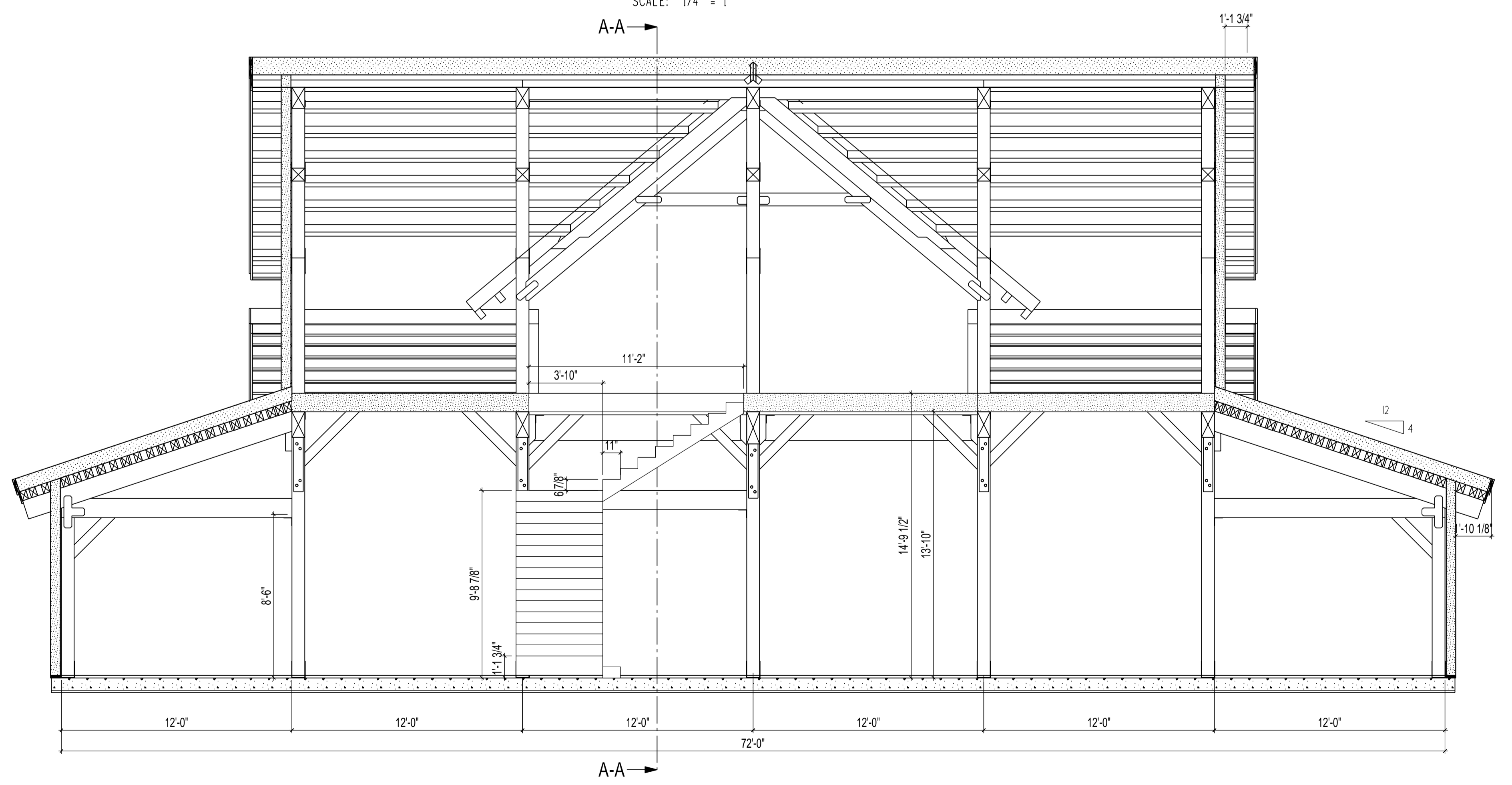

BUILDING SECTION B-B

SCALE: 1/4" = 1'

CUSTOMER INFORMATION:
PENDER
 SPORTS COMPLEX

PROJECT INFORMATION:
PENDER
COMPLEX
 100 SLAUGHTER
 PENDER, NE 68047
 NUMBER: JGE1122-1 PSC
 CATEGORY: COMMERCIAL
 STYLE: GREAT PLAINS WESTERN
 OTHER: --
 OTHER: --
 PM: --

DRAWING INFORMATION:
 DRAWN BY: BJ
 DATE: 09/13/2023
 STATUS: FINAL PLAN SET
 OTHER: --
 OTHER: --

SHEET NOTES

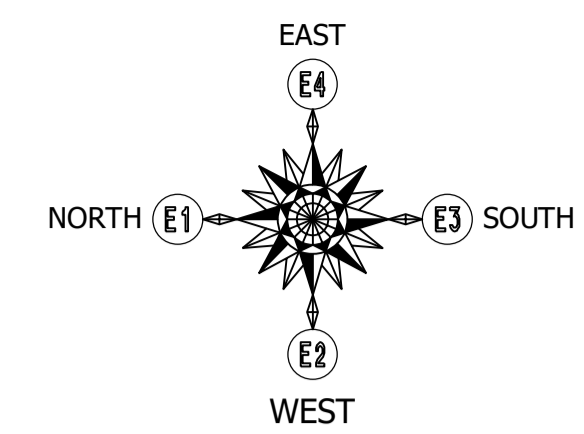

© 2021 Timberlyne. All Rights Reserved.
 THIS PLAN AND DESIGNS CONTAINED HEREIN ARE THE
 PROPERTY OF TIMBERLYNE GROUP™ AND MAY NOT BE
 REPRODUCED WITHOUT PRIOR WRITTEN CONSENT FROM
 TIMBERLYNE GROUP™.

CUSTOMER INFORMATION:
PENDER
 SPORTS COMPLEX

PROJECT INFORMATION:
PENDER
COMPLEX
 100 SLAUGHTER
 PENDER, NE 68047
 NUMBER: JGE1122-1 PSC
 CATEGORY: COMMERCIAL
 STYLE: GREAT PLAINS WESTERN
 OTHER: --
 OTHER: --
 PM: --

DRAWING INFORMATION:
 DRAWN BY: BJ
 DATE: 09/13/2023
 STATUS: FINAL PLAN SET
 OTHER: --
 OTHER: --

SHEET NOTES

SHEET
S5

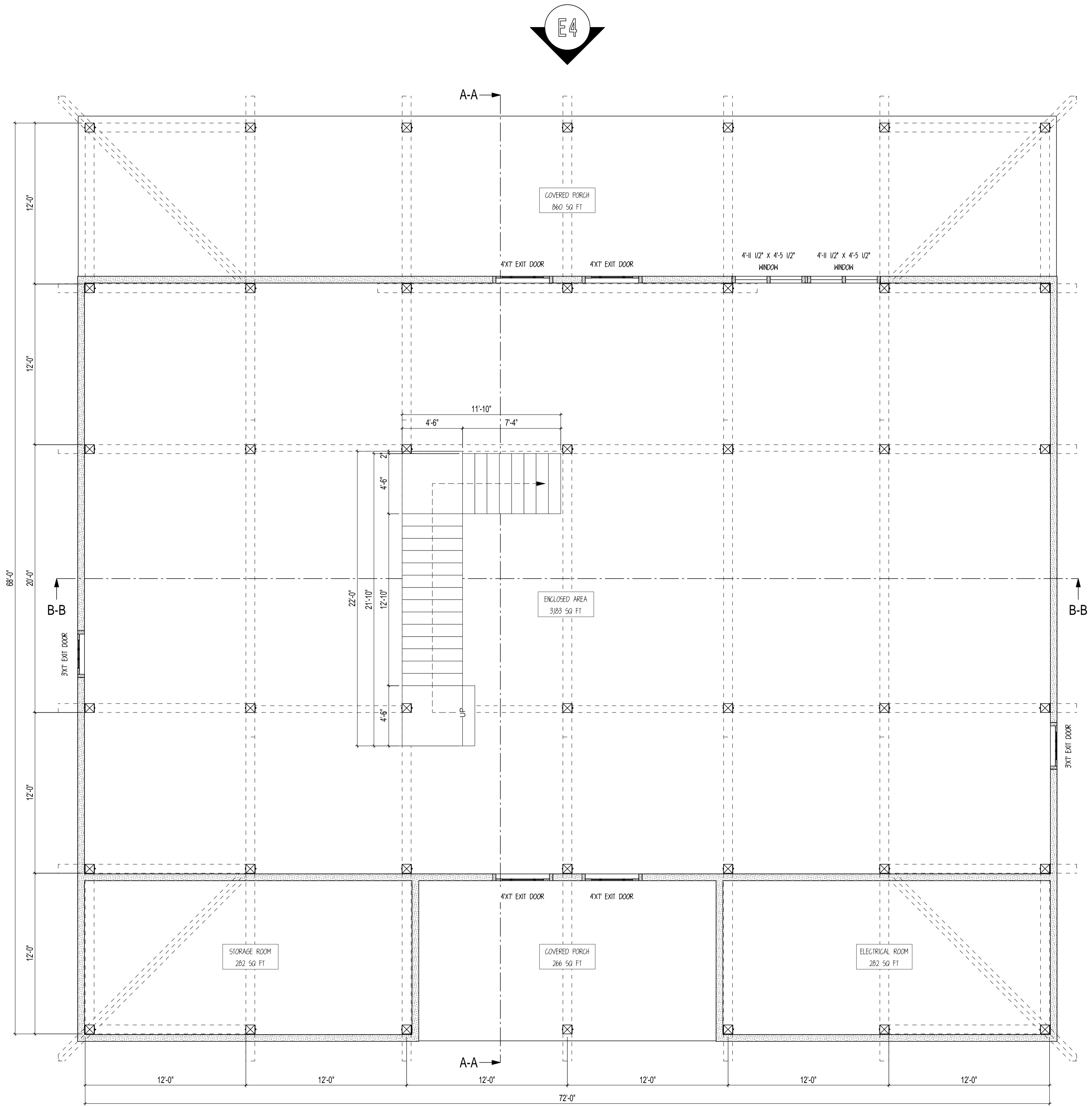

MAIN FLOOR LAYOUT

SCALE: 1/4" = 1'

SHEET NOTES:
 1. FLOOR LAYOUT DRAWINGS ARE NOT DESIGNED BY AN ARCHITECT. ADDITIONAL PROFESSIONAL SERVICES MAY BE REQUIRED TO COMPLY WITH LOCAL CODES AND REGULATIONS.
 2. TIMBERLYNE IS NOT RESPONSIBLE FOR DESIGNING ELECTRICAL, PLUMBING, AND HVAC PLANS.
 3. INTERIOR PARTITION WALLS, WINDOWS, DOORS, AND FIXTURES ARE PROVIDED BY CUSTOMER OR GENERAL CONTRACTOR.
 4. DAYLIGHT OPENING, VENT OPENING, AND EGRESS REQUIREMENTS ARE THE RESPONSIBILITY OF THE CUSTOMER/GENERAL CONTRACTOR.
 5. DOOR AND WINDOW LOCATIONS ARE APPROX. ONLY. EXACT LOCATION TO BE DETERMINED BY THE CUSTOMER AND GENERAL CONTRACTOR.

NOTE: WINDOWS AND DOORS NOT SUPPLIED BY TIMBERLYNE

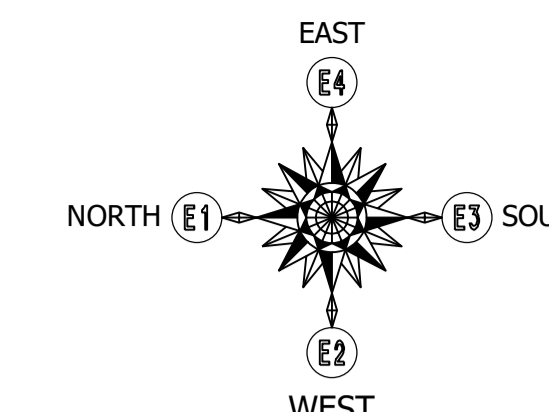

© 2021 Timberlyne. All Rights Reserved.
 THIS PLAN AND DESIGNS CONTAINED HEREIN ARE THE
 PROPERTY OF TIMBERLYNE GROUP™ AND MAY NOT BE
 REPRODUCED WITHOUT PRIOR WRITTEN CONSENT FROM
 TIMBERLYNE GROUP™.

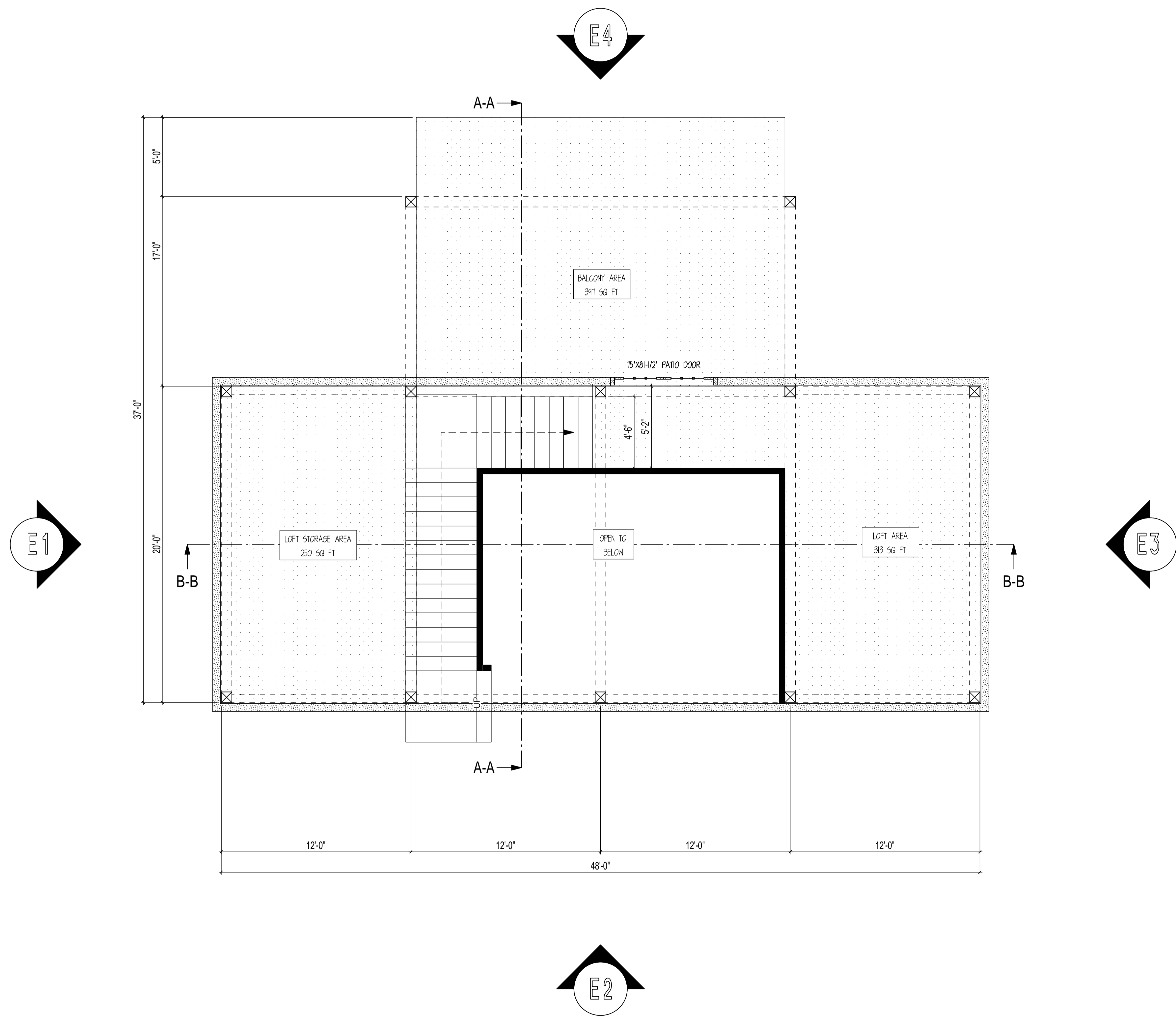

LOFT FLOOR LAYOUT

SCALE: 1/4" = 1'

CUSTOMER INFORMATION:
PENDER
 SPORTS COMPLEX

PROJECT INFORMATION:
PENDER
COMPLEX
 100 SLAUGHTER
 PENDER, NE 68047
 NUMBER: JGE1122-1 PSC
 CATEGORY: COMMERCIAL
 STYLE: GREAT PLAINS WESTERN
 OTHER: --
 OTHER: --
 PM: --

DRAWING INFORMATION:
 DRAWN BY: BJ
 DATE: 09/13/2023
 STATUS: FINAL PLAN SET
 OTHER: --
 OTHER: --

SHEET NOTES

SHEET

S6

SHEET NOTES:
 1. FLOOR LAYOUT DRAWINGS ARE NOT DESIGNED BY AN ARCHITECT. ADDITIONAL PROFESSIONAL SERVICES MAY BE REQUIRED TO COMPLY WITH LOCAL CODES AND REGULATIONS.
 2. TIMBERLYNE IS NOT RESPONSIBLE FOR DESIGNING ELECTRICAL, PLUMBING, AND HVAC PLANS.
 3. INTERIOR PARTITION WALLS, WINDOWS, DOORS, AND FIXTURES ARE PROVIDED BY CUSTOMER OR GENERAL CONTRACTOR.
 4. DAYLIGHT OPENING, VENT OPENING, AND EGRESS REQUIREMENTS ARE THE RESPONSIBILITY OF THE CUSTOMER/GENERAL CONTRACTOR.
 5. DOOR AND WINDOW LOCATIONS ARE APPROX. ONLY. EXACT LOCATION TO BE DETERMINED BY THE CUSTOMER AND GENERAL CONTRACTOR.

NOTE: WINDOWS AND DOORS NOT SUPPLIED BY TIMBERLYNE

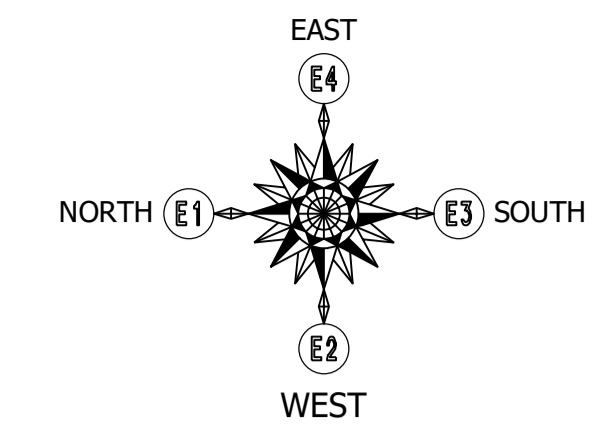

© 2021 Timberlyne. All Rights Reserved.
 THIS PLAN AND DESIGNS CONTAINED HEREIN ARE THE
 PROPERTY OF TIMBERLYNE GROUP™ AND MAY NOT BE
 REPRODUCED WITHOUT PRIOR WRITTEN CONSENT FROM
 TIMBERLYNE GROUP™.

CUSTOMER INFORMATION:

**PENDER
 SPORTS COMPLEX**

PROJECT INFORMATION:

**PENDER
 COMPLEX**
 100 SLAUGHTER
 PENDER, NE 68047
 NUMBER: JGE1122-1 PSC
 CATEGORY: COMMERCIAL
 STYLE: GREAT PLAINS WESTERN
 OTHER: --
 OTHER: --
 PM: --

DRAWING INFORMATION:

DRAWN BY: BJ
 DATE: 09/13/2023
 STATUS: FINAL PLAN SET
 OTHER: --
 OTHER: --

SHEET NOTES

1. FOUNDATION DIMENSIONS TO BE VERIFIED BY GENERAL CONTRACTOR BEFORE ERECTION OF FRAME.
2. CHECK LOCAL CODE FOR MINIMUM FOOTING DEPTH.
3. REFER TO COVER SHEET FOR FURTHER INFORMATION ON FOUNDATION AND REBAR.

SHEET

S7

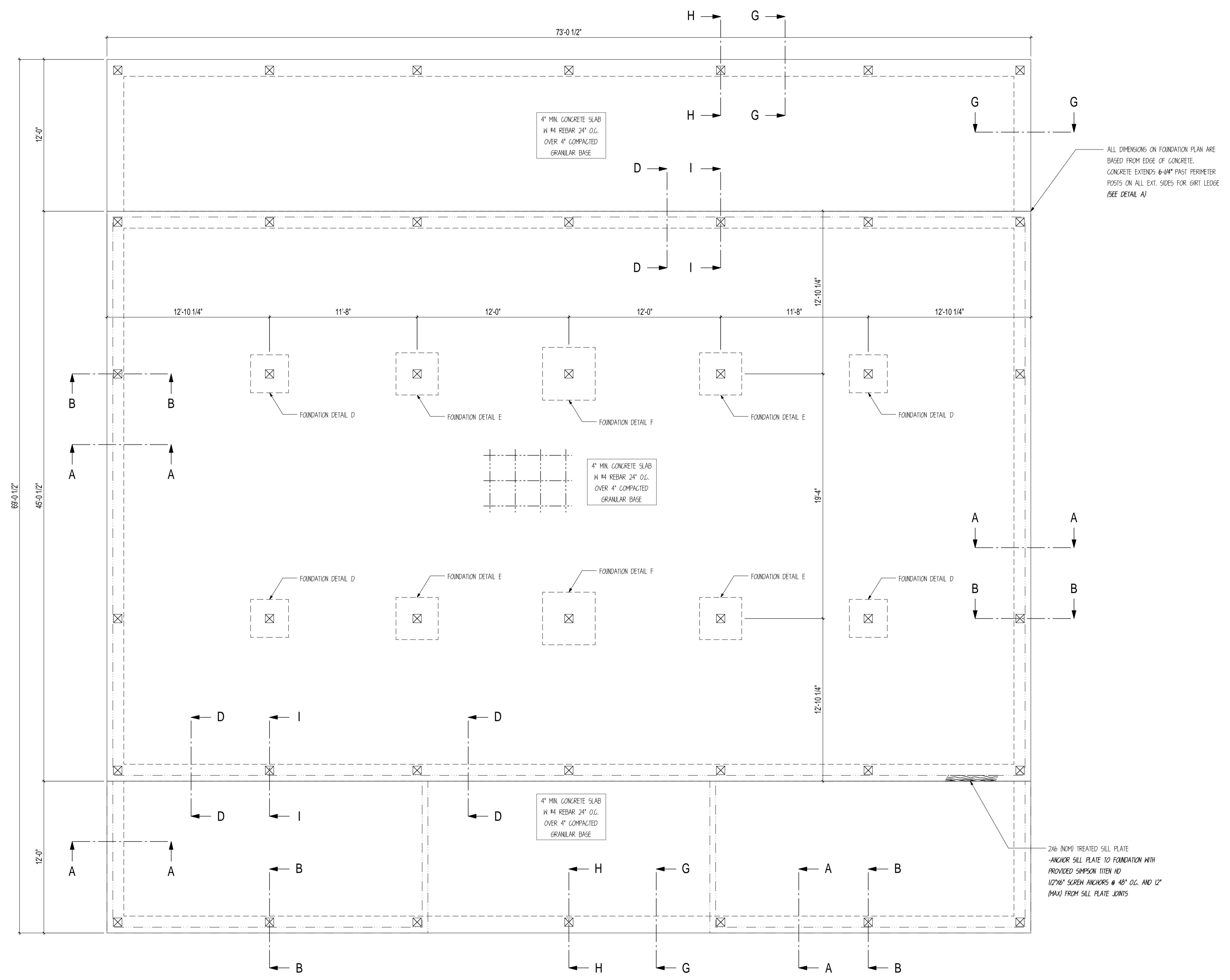

FOUNDATION PLAN
 SCALE: 1/4" = 1'

SCREW ANCHOR INFORMATION

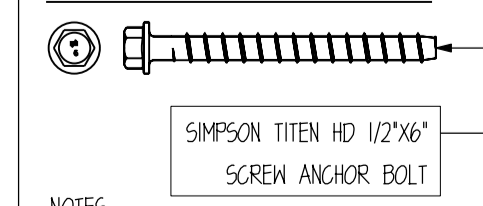

- NOTES:
1. USED FOR POST ATTACHMENT.
 2. USED TO ATTACH CEDAR SILL TO CONCRETE.
 3. USE 1/2\"/>

CUSTOMER INFORMATION:

**PENDER
SPORTS COMPLEX**

PROJECT INFORMATION:

**PENDER
COMPLEX**

100 SLAUGHTER
PENDER, NE 68047

NUMBER: JGE1122-1 PSC

CATEGORY: COMMERCIAL

STYLE: GREAT PLAINS WESTERN

OTHER: --

OTHER: --

PM: --

DRAWING INFORMATION:

DRAWN BY: BJ

DATE: 09/13/2023

STATUS: FINAL PLAN SET

OTHER: --

OTHER: --

SHEET NOTES

- FOUNDATION DIMENSIONS TO BE VERIFIED BY GENERAL CONTRACTOR BEFORE ERECTION OF FRAME.
- CHECK LOCAL CODE FOR MINIMUM FOOTING DEPTH.
- REFER TO COVER SHEET FOR FURTHER INFORMATION ON FOUNDATION AND REBAR.

SHEET

S8

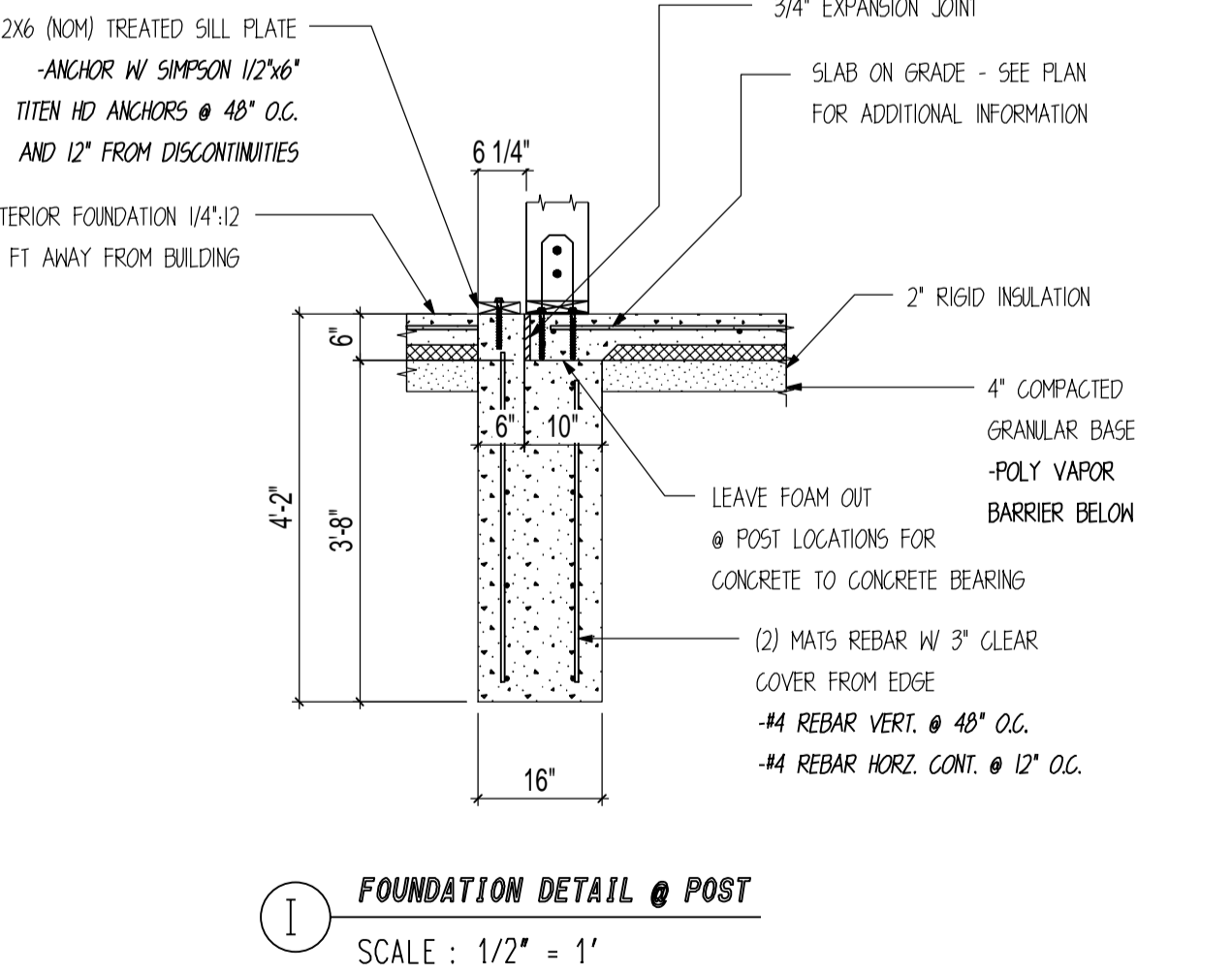
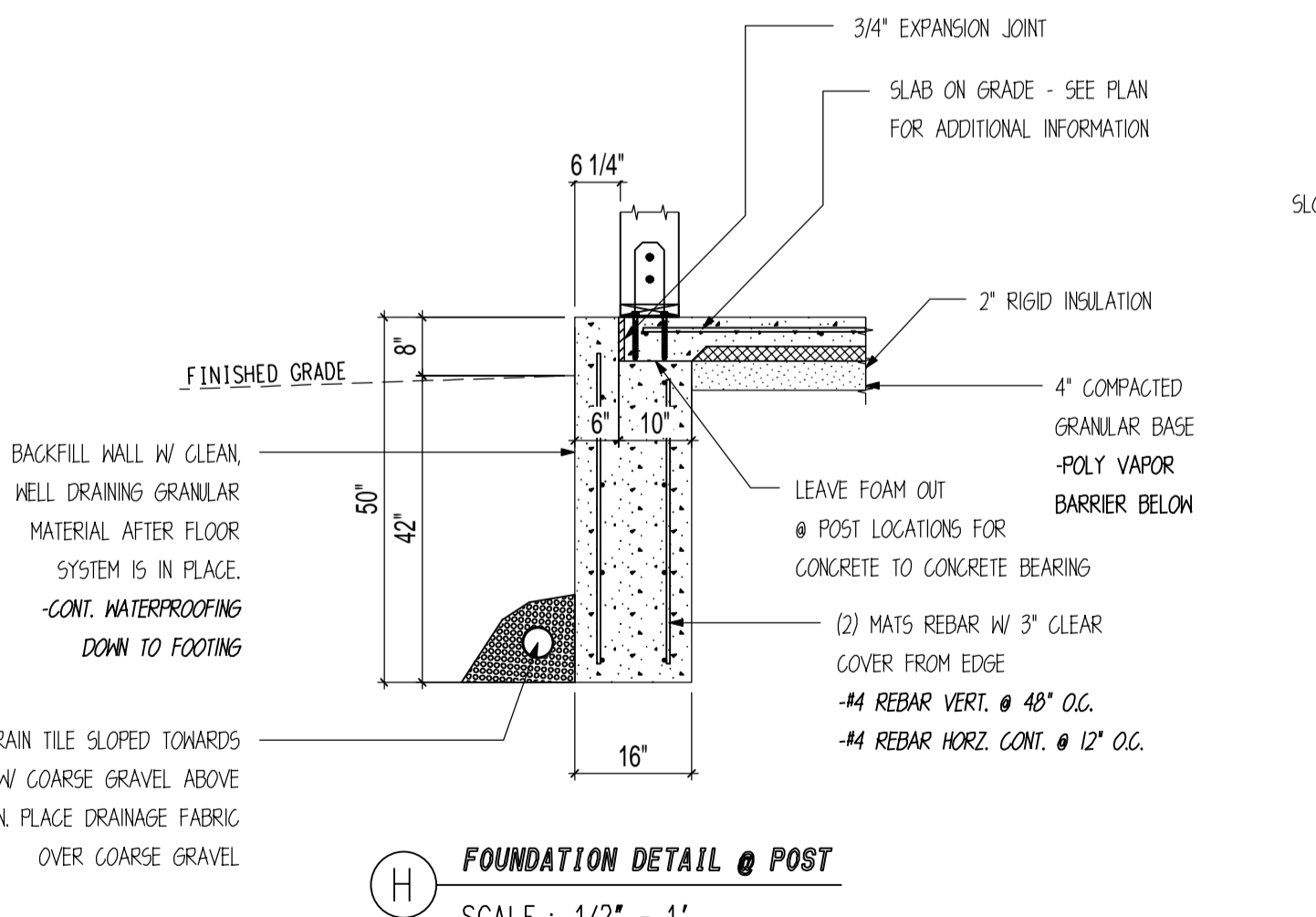
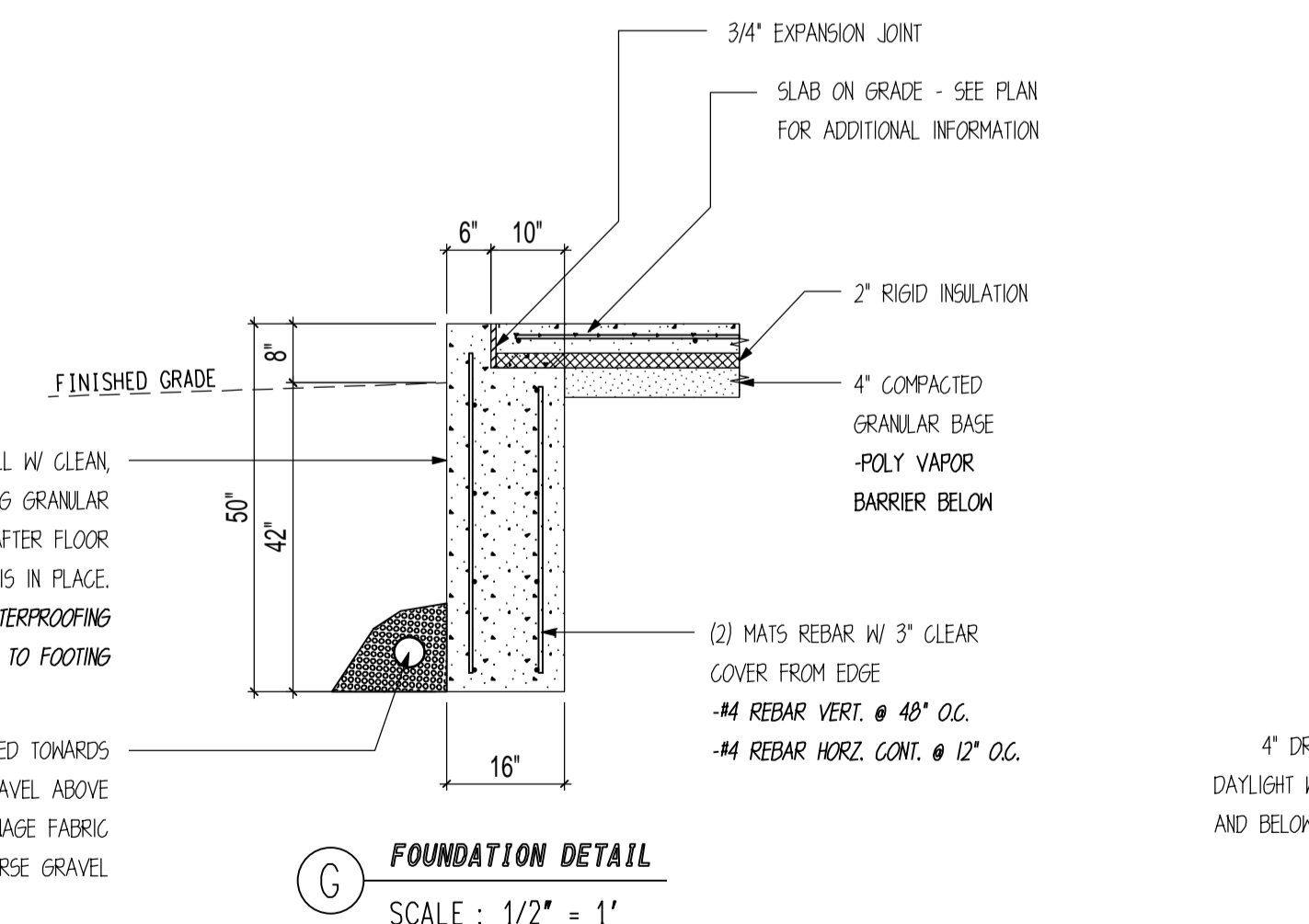
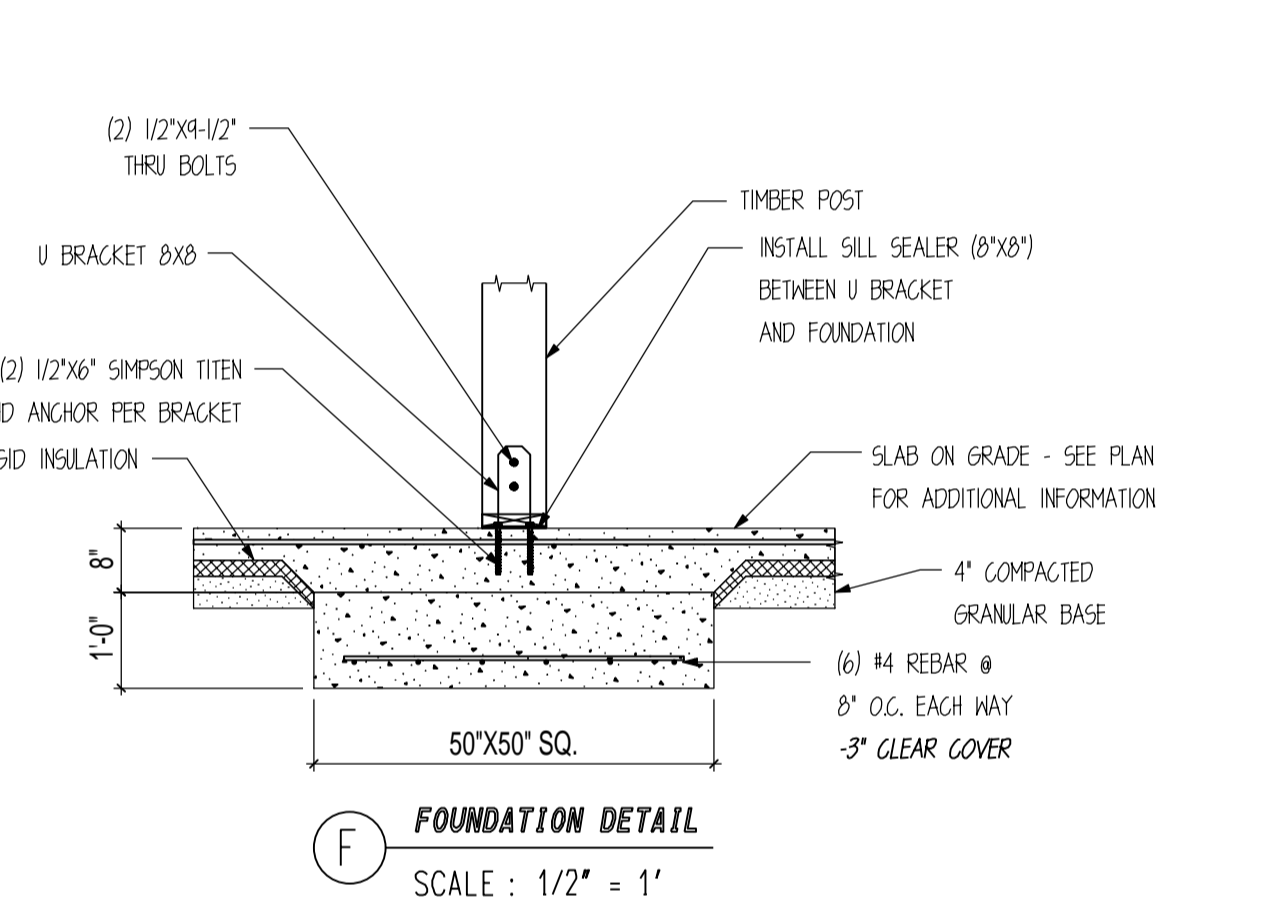
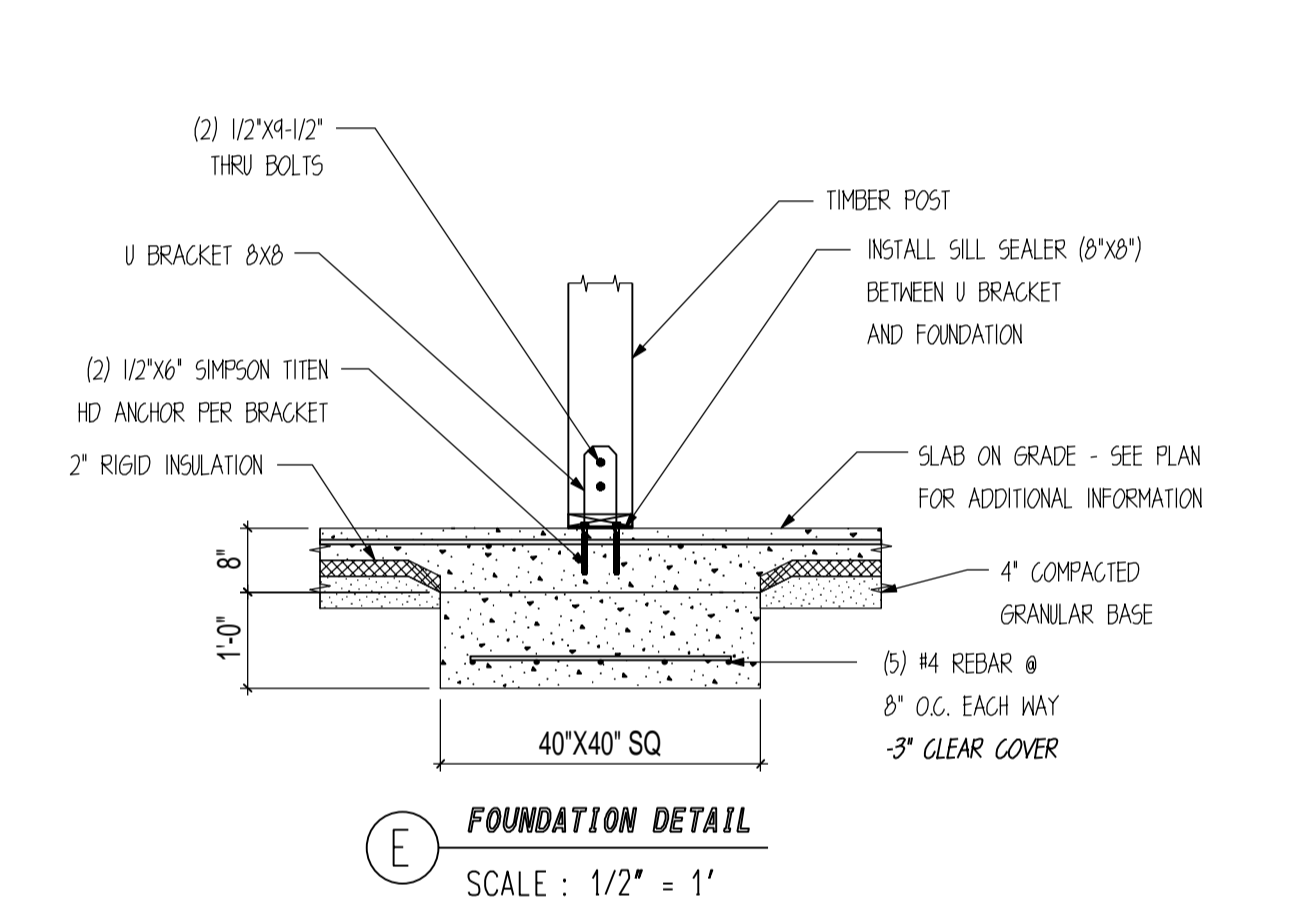
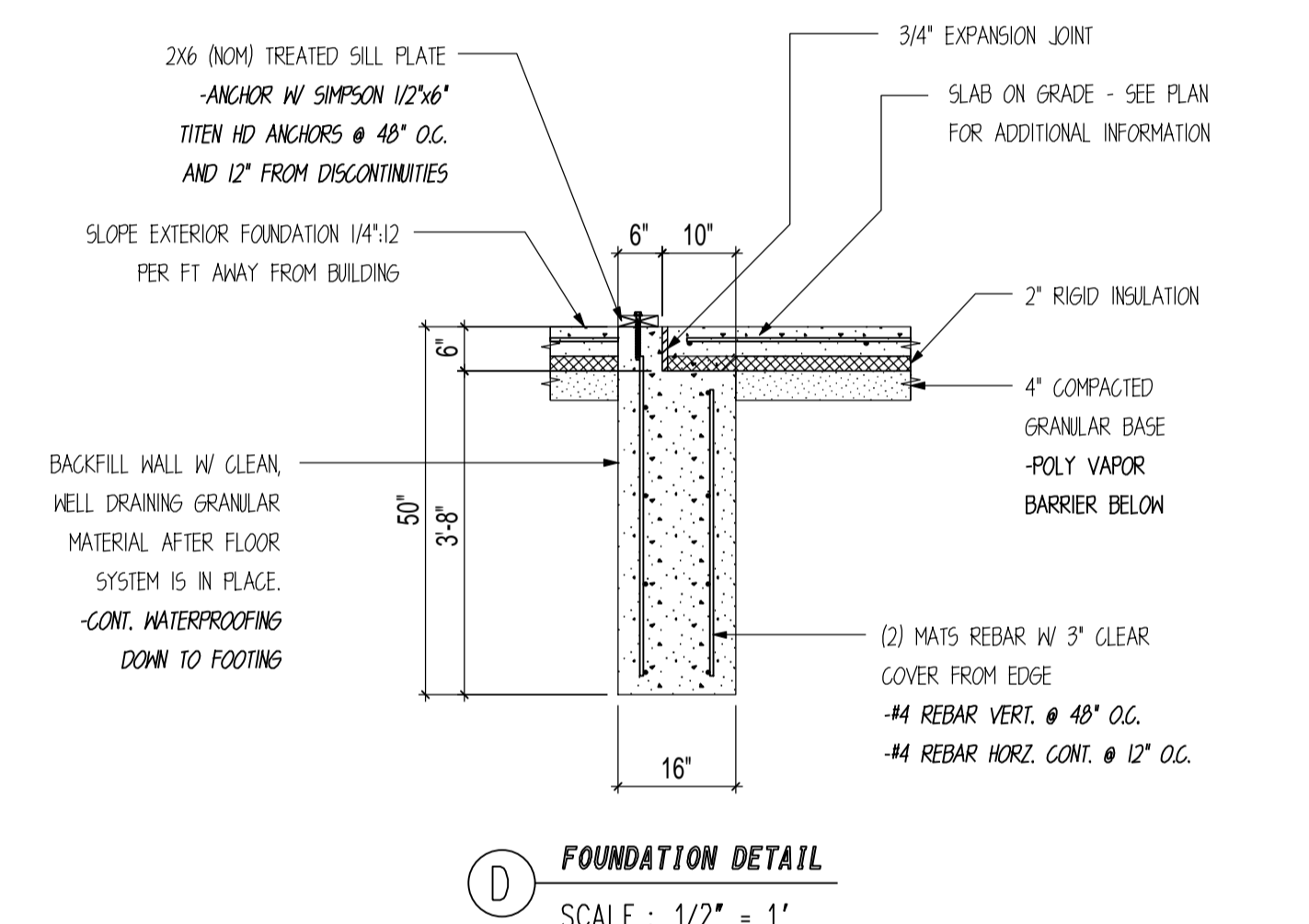
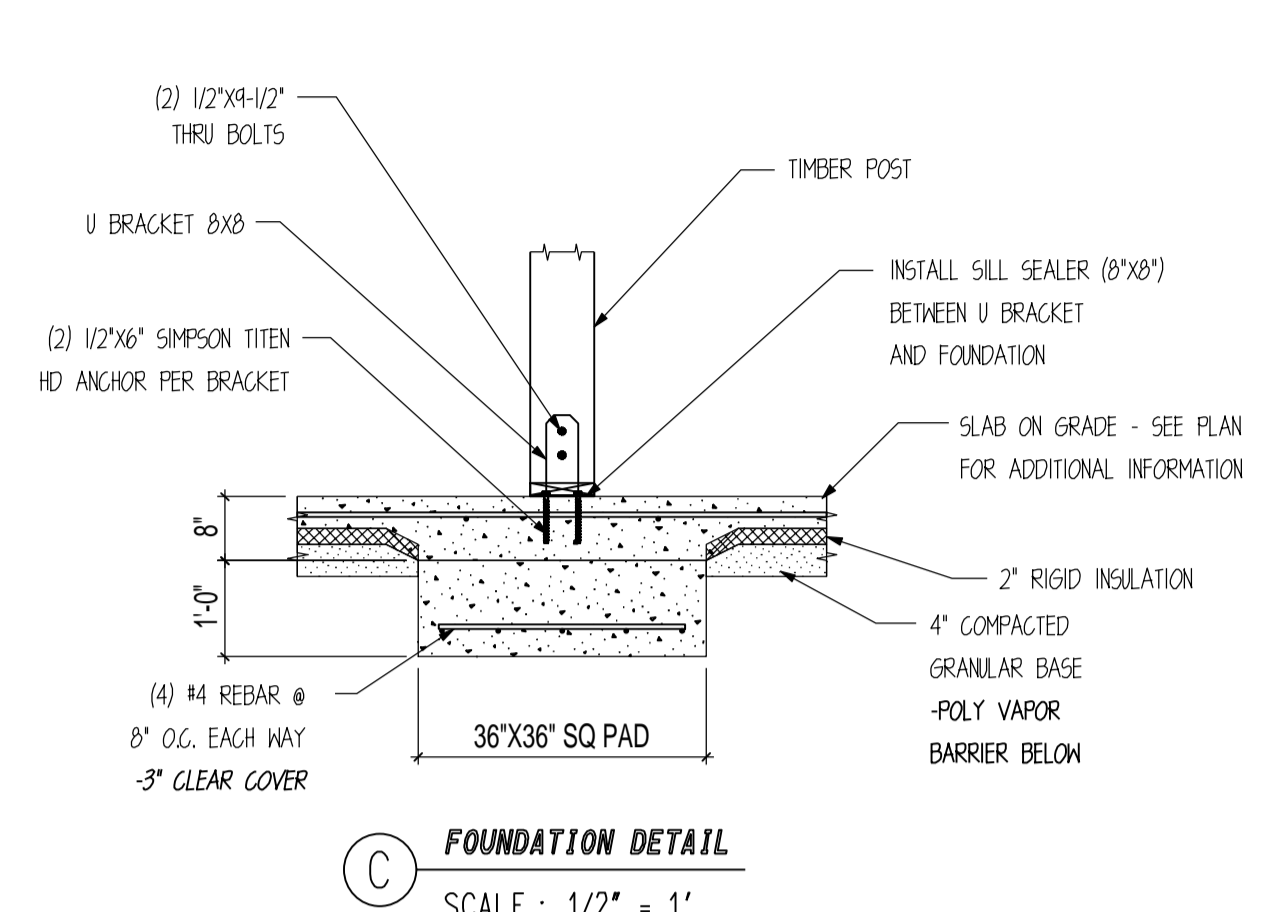
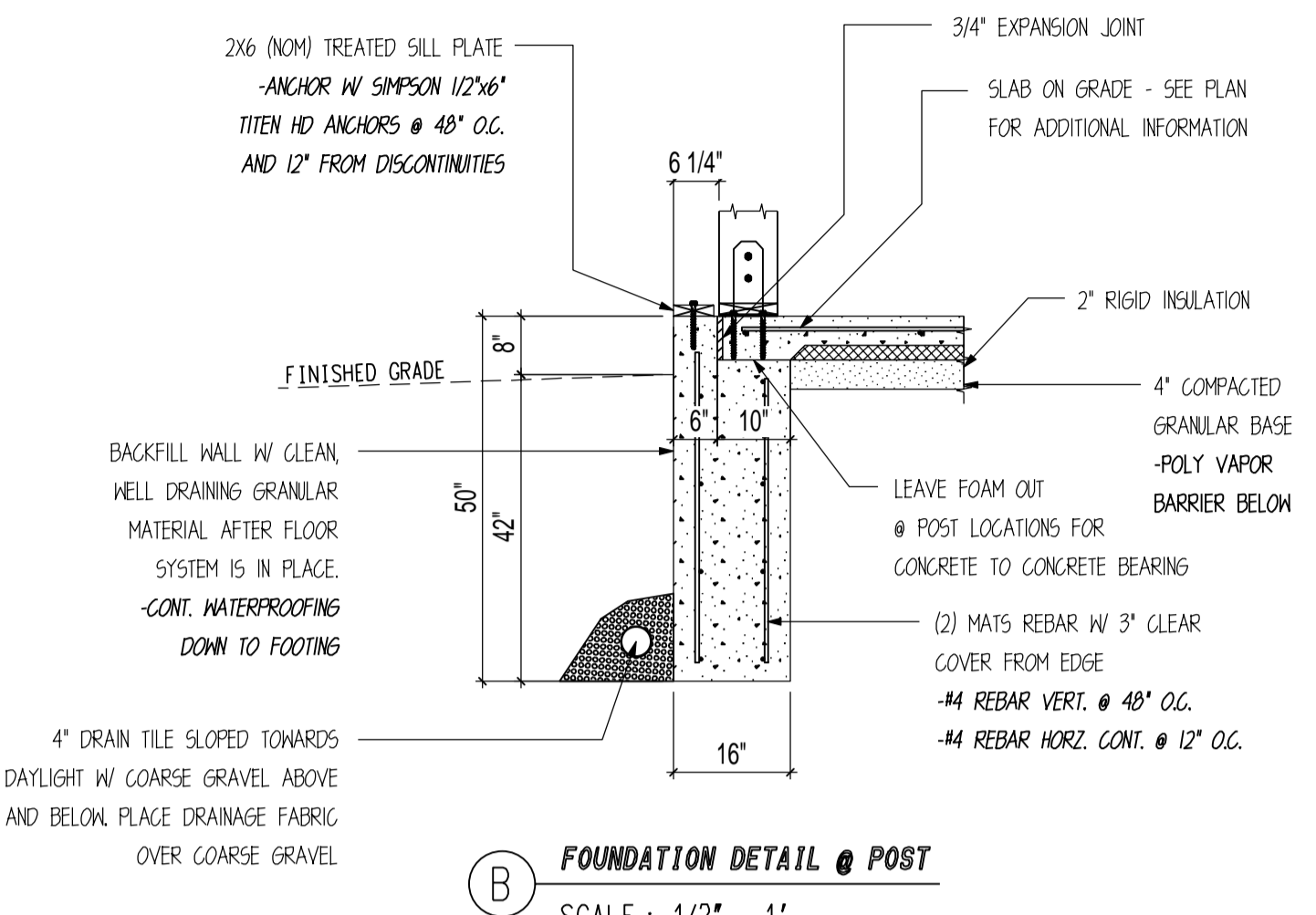
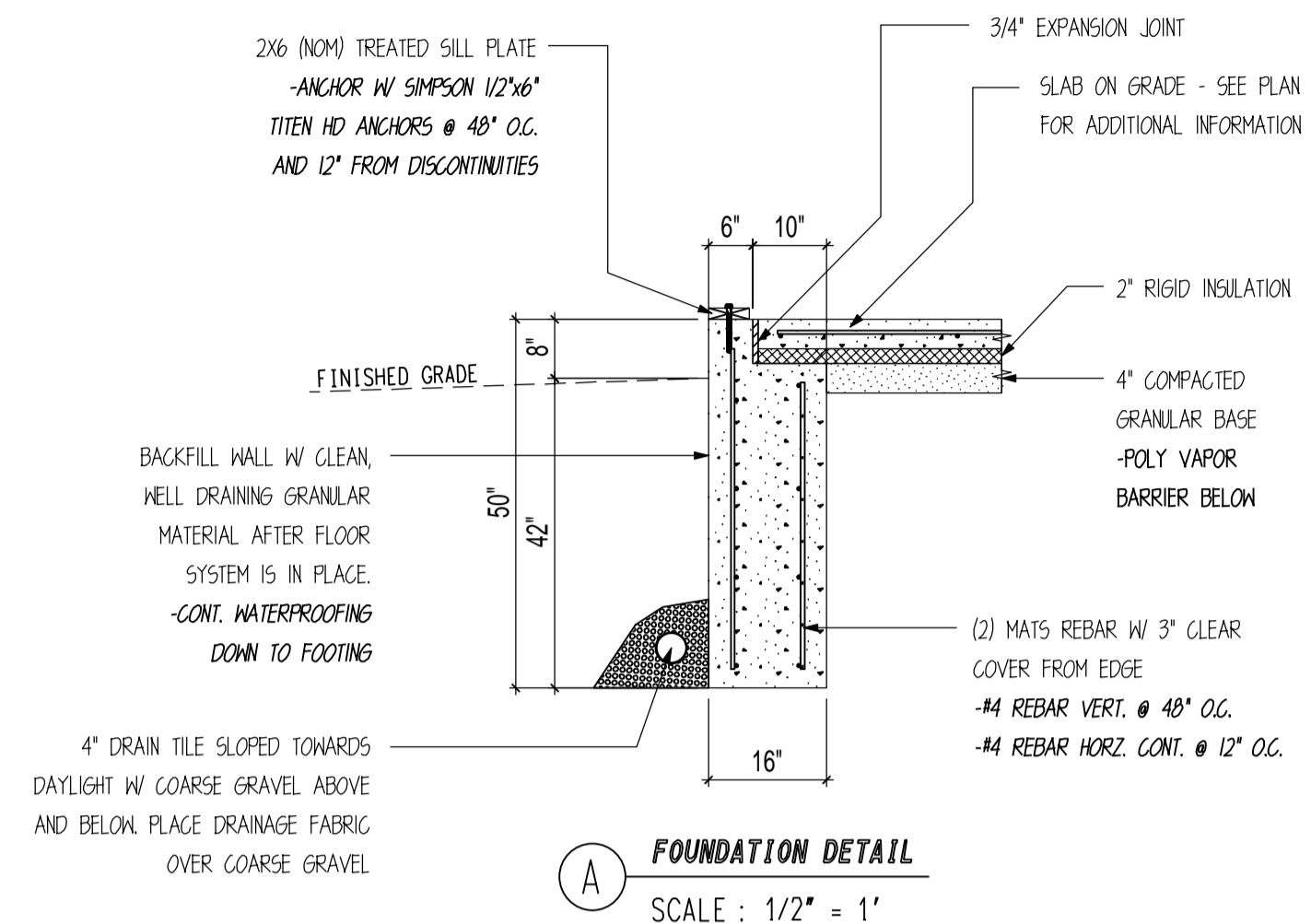

SCREW ANCHOR INFORMATION

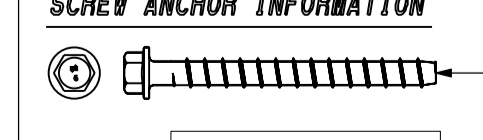

- NOTES:
- USED FOR POST ATTACHMENT.
 - USED TO ATTACH CEDAR SILL TO CONCRETE.
 - USE 1/2" DIA. MASONRY BIT TO PRE-DRILL.

CUSTOMER INFORMATION:

PENDER
SPORTS COMPLEX

PROJECT INFORMATION:

PENDER
COMPLEX

100 SLAUGHTER
 PENDER, NE 68047
 NUMBER: JGE1122-1 PSC

CATEGORY: COMMERCIAL

STYLE: GREAT PLAINS WESTERN

OTHER: --

OTHER: --

PM: --

DRAWING INFORMATION:

DRAWN BY: BJ

DATE: 09/13/2023

STATUS: FINAL PLAN SET

OTHER: --

OTHER: --

SHEET NOTES

1. BASE OF MAIN FRAME POST CUT TO FIT IN
 FIELD BY GENERAL CONTRACTOR ACCORDING
 TO SPECS ON CUT LISTS. CUT BOTTOM OF
 POST ONLY.

SHEET

S9

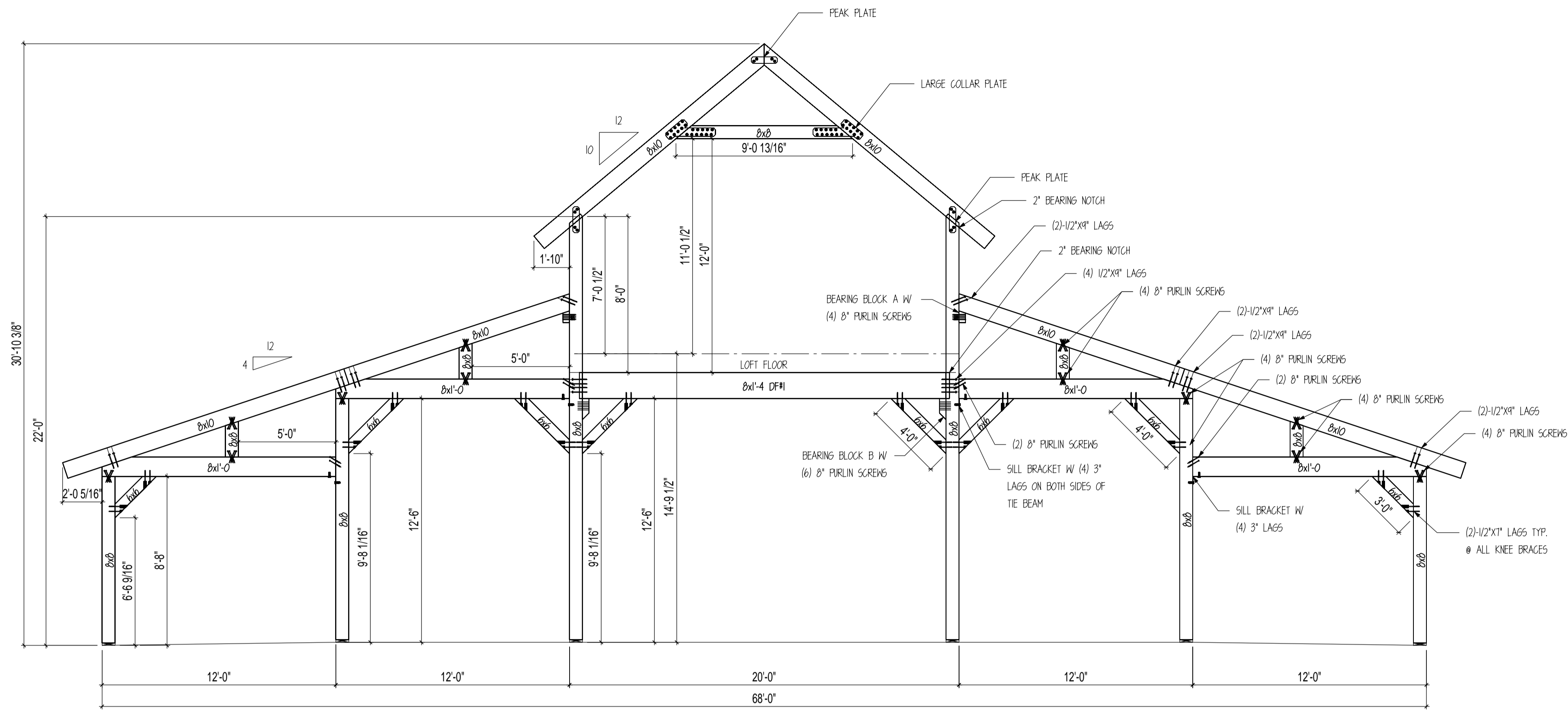

BENT #1
 SCALE: 1/4" = 1'

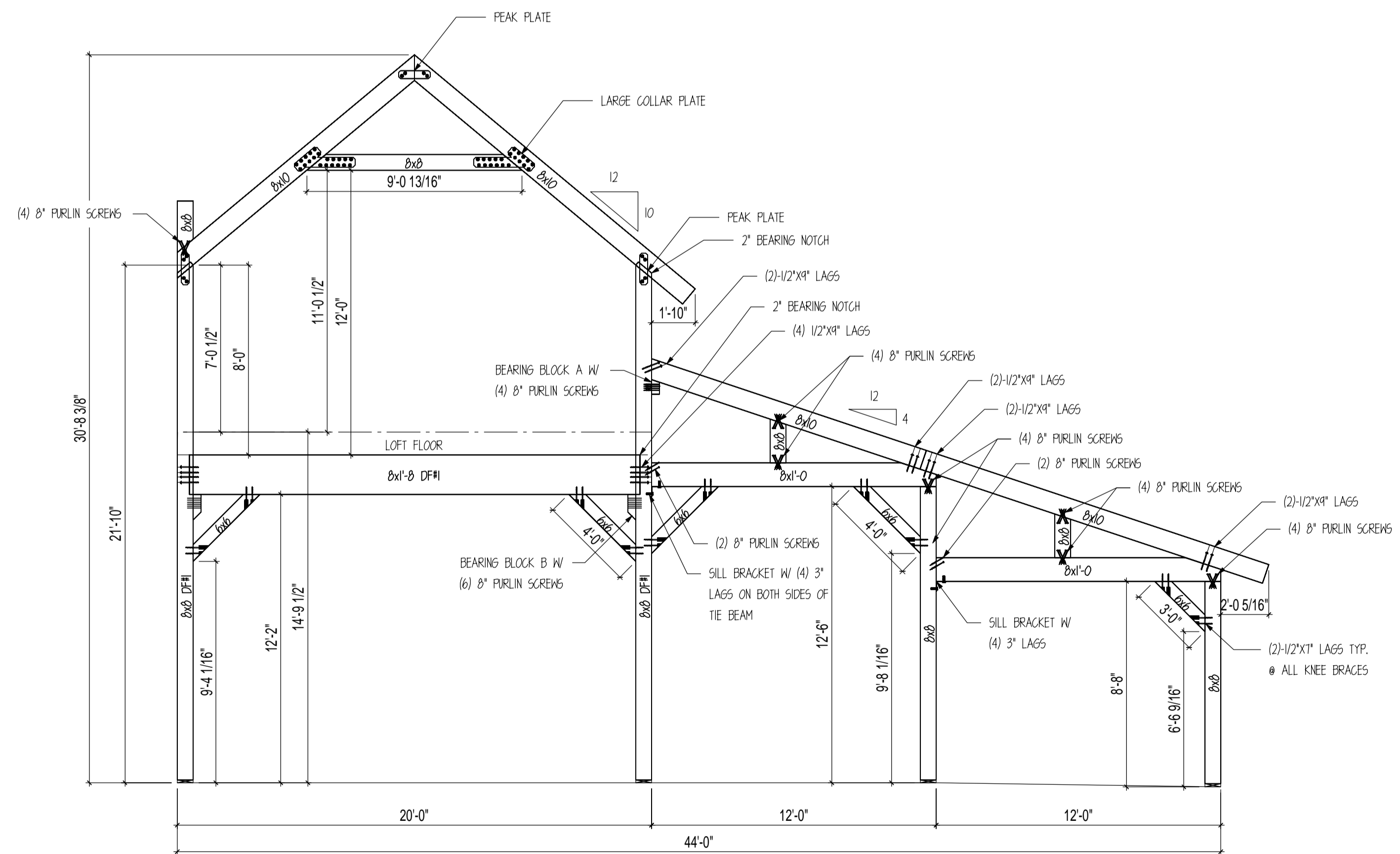

BENT #2
 SCALE: 1/4" = 1'

STANDARD STEEL JOINERY

PLATES

-USE PROVIDED ZINC COATED 1/2"x1/2" THRU BOLTS (A307 MIN)
 -2 PLATES ARE USED PLACE 1 PLATE ON EACH SIDE OF BENT UNLESS NOTED OTHERWISE ON PLANS

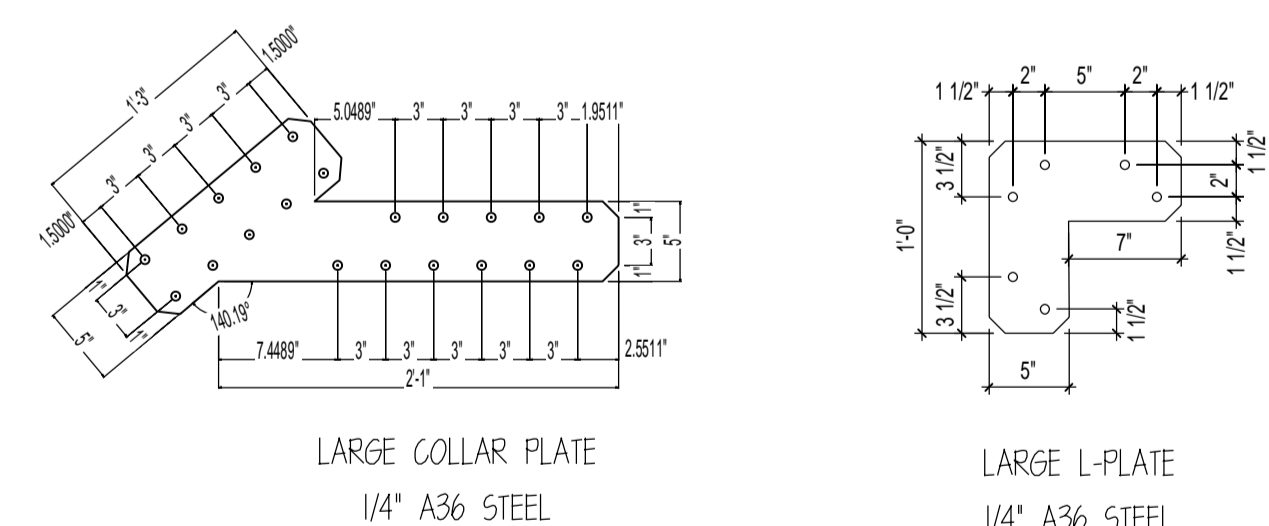

BRACKETS

-USE PROVIDED ZINC COATED 1/2" DIA. LAG BOLTS (GRADE 5 MIN)
 -1/2"x6" SIMPSON TITEN HD ZINC COATED ANCHORS @ FOUNDATION
 -USE PROVIDED ZINC COATED 1/2"x1/2" THRU BOLTS (A307 MIN)

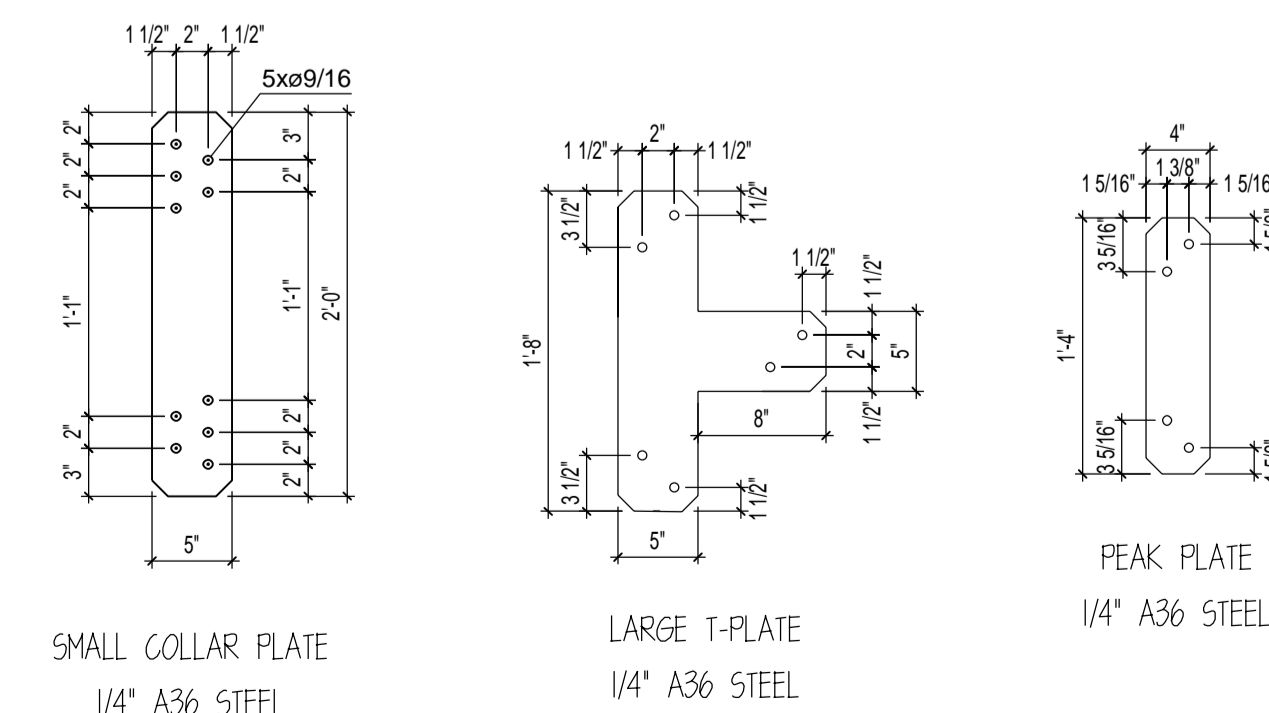
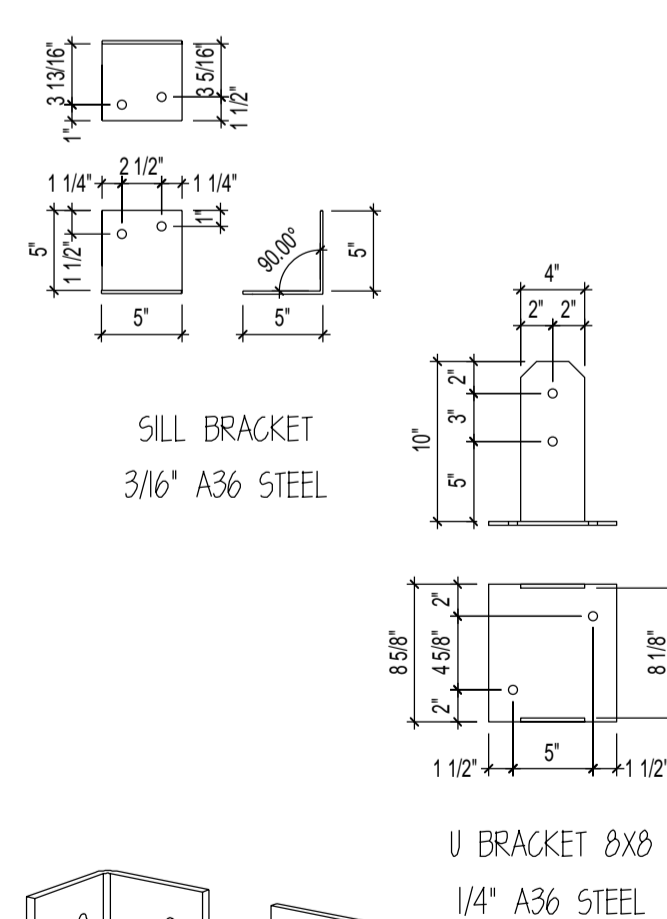

4" GIRTS (CONSTRUCTION LAG SCREW)	8" PURLIN SCREWS (CONSTRUCTION LAG SCREW)
THREAD DIA: #15 OR .265	THREAD DIA: #17 OR .310
HEAD DIA: 5/8"	SHANK DIA: .226
SHANK DIA: .205	RECESS SIZE: T40
RECESS SIZE: T30	ALL 1/2" LAGS ARE ZINC COATED GRADE 5
6" GIRTS (CONSTRUCTION LAG SCREW)	
THREAD DIA: #15 OR .265	
HEAD DIA: 5/8"	
SHANK DIA: .205	
RECESS SIZE: T30	

8" CF HANGER
 1/4" A36 STEEL
 -USE SIMPSON SSS 1/4"x3" SCREWS OR EQUIV.
 -120 TOTAL SCREWS PER HANGER
 -TYP. @ ALL HANGER LOCATIONS

CUSTOMER INFORMATION:

PENDER

SPORTS COMPLEX

PROJECT INFORMATION:

PENDER

COMPLEX

100 SLAUGHTER
PENDER, NE 68047

NUMBER: JGE1122-1 PSC

CATEGORY: COMMERCIAL

STYLE: GREAT PLAINS WESTERN

OTHER: --

OTHER: --

PM: --

DRAWING INFORMATION:

DRAWN BY: BJ

DATE: 09/13/2023

STATUS: FINAL PLAN SET

OTHER: --

OTHER: --

SHEET NOTES

1. BASE OF MAIN FRAME POST CUT TO FIT IN
FIELD BY GENERAL CONTRACTOR ACCORDING
TO SPECS ON CUT LISTS. CUT BOTTOM OF
POST ONLY.

SHEET

S10

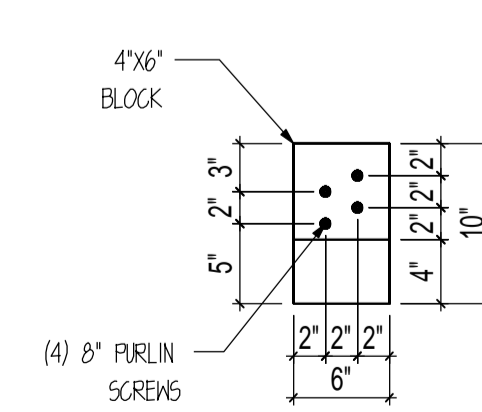
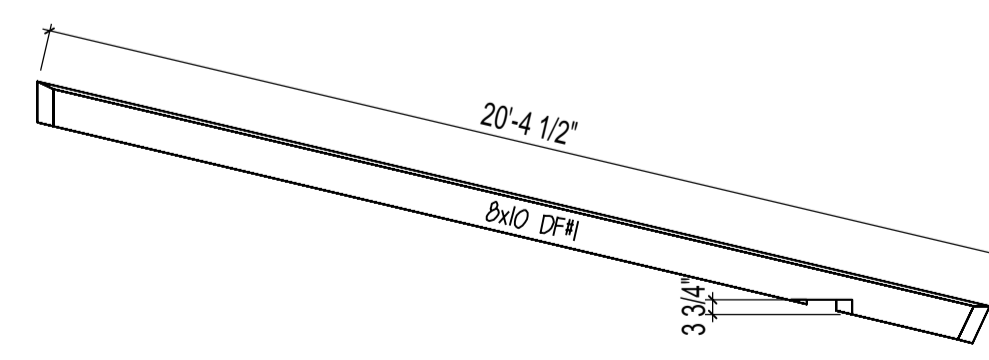
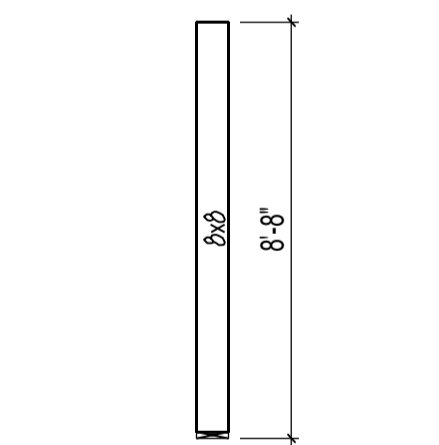
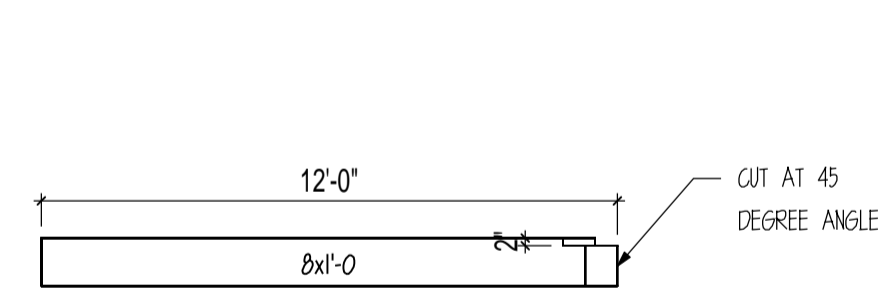
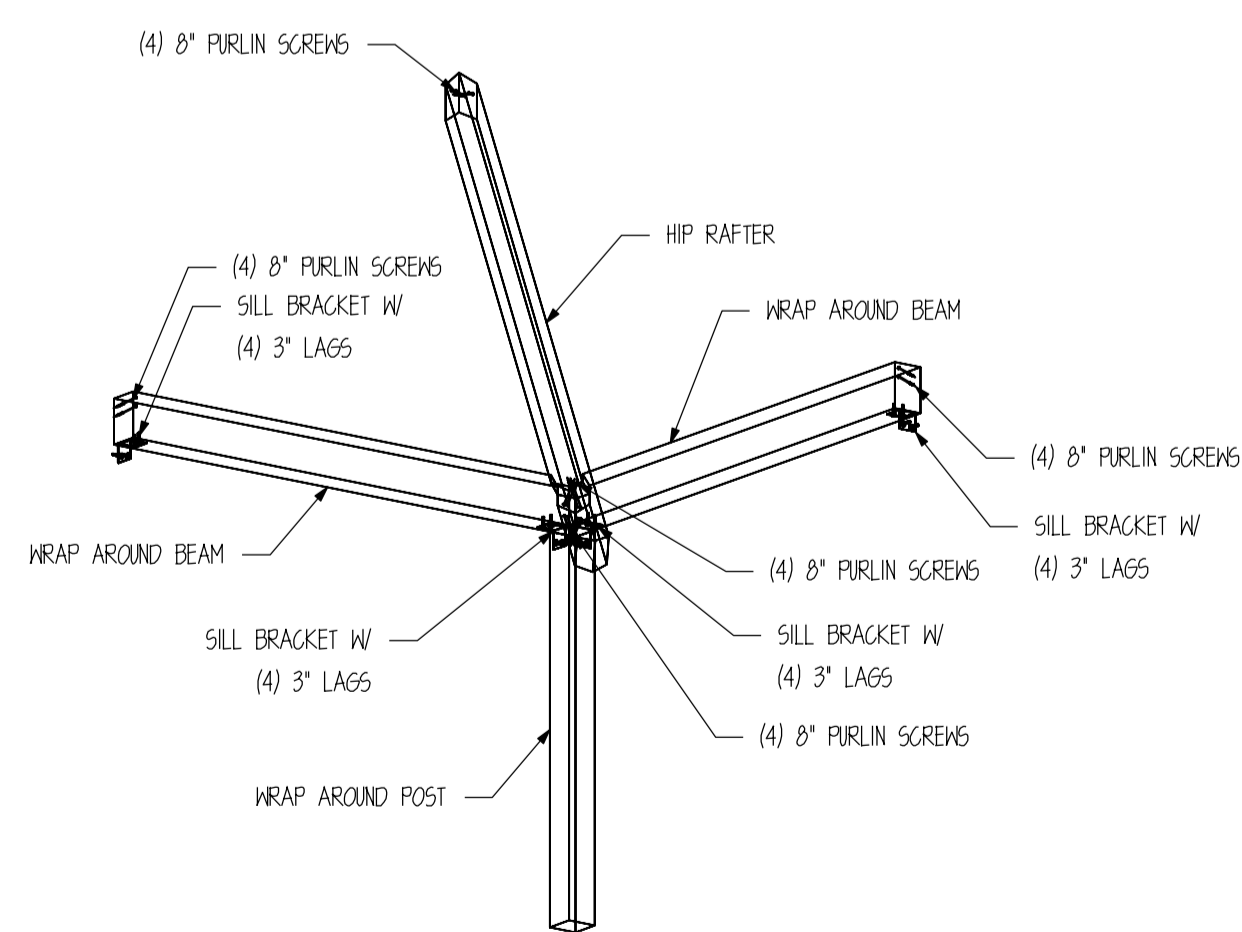
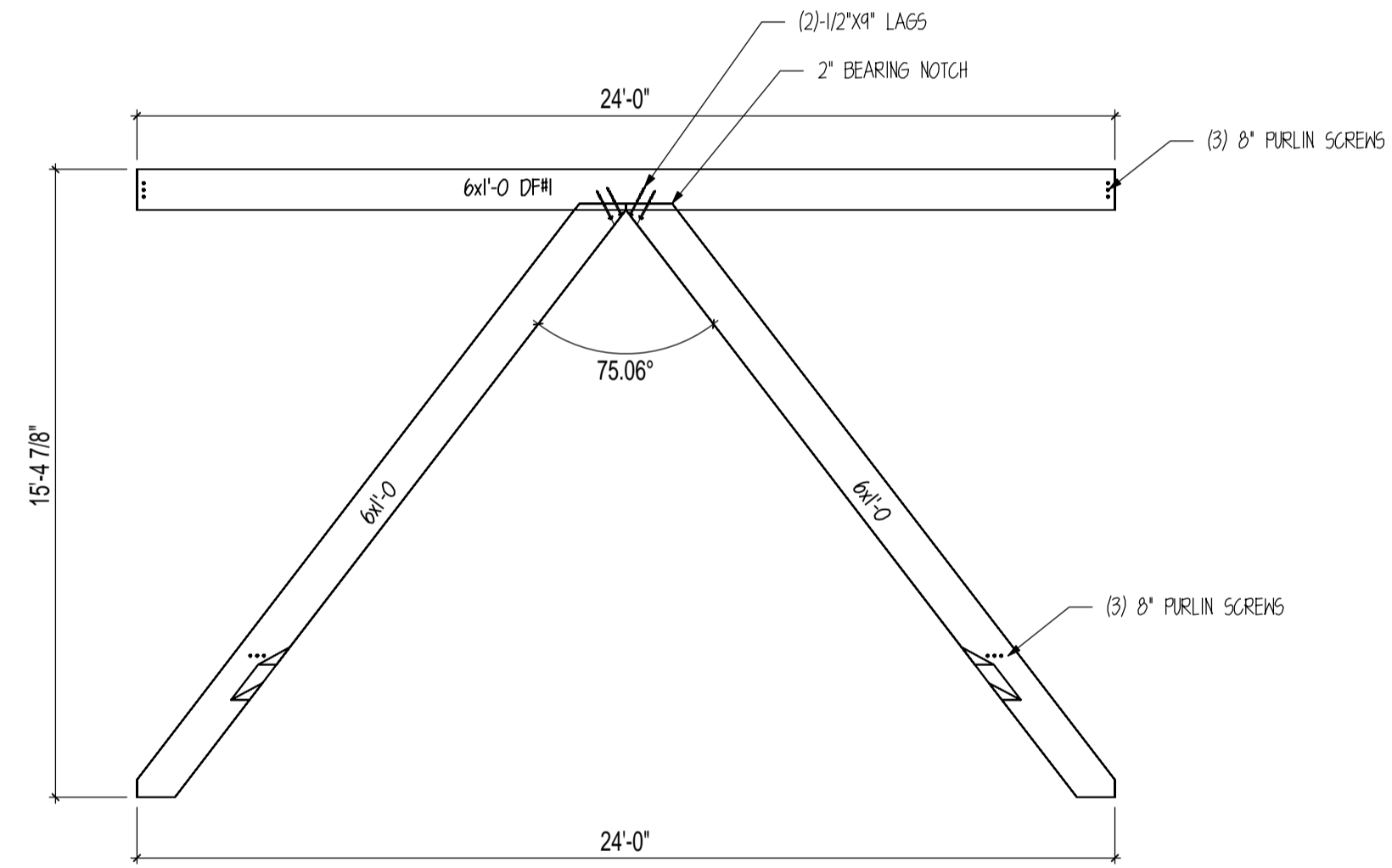
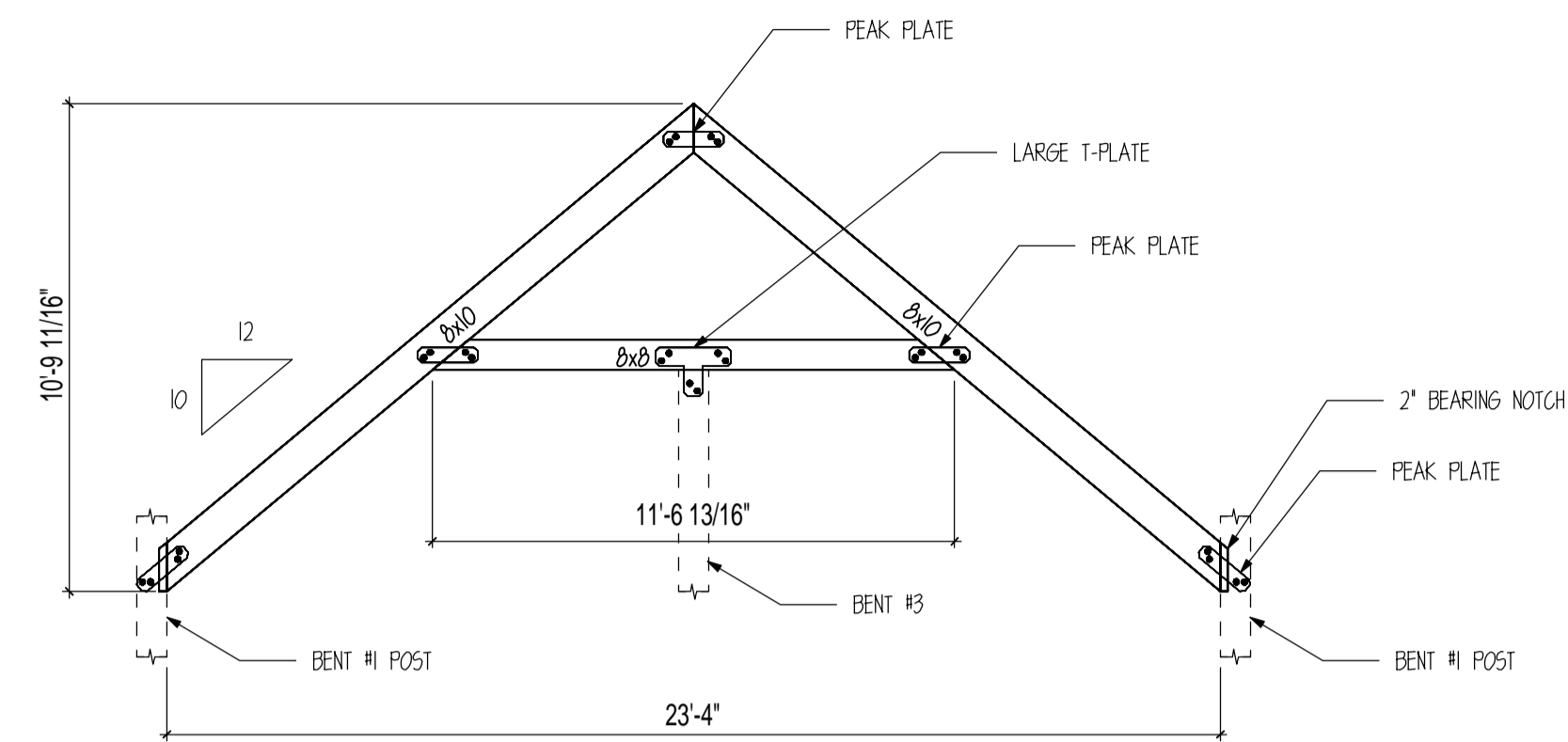
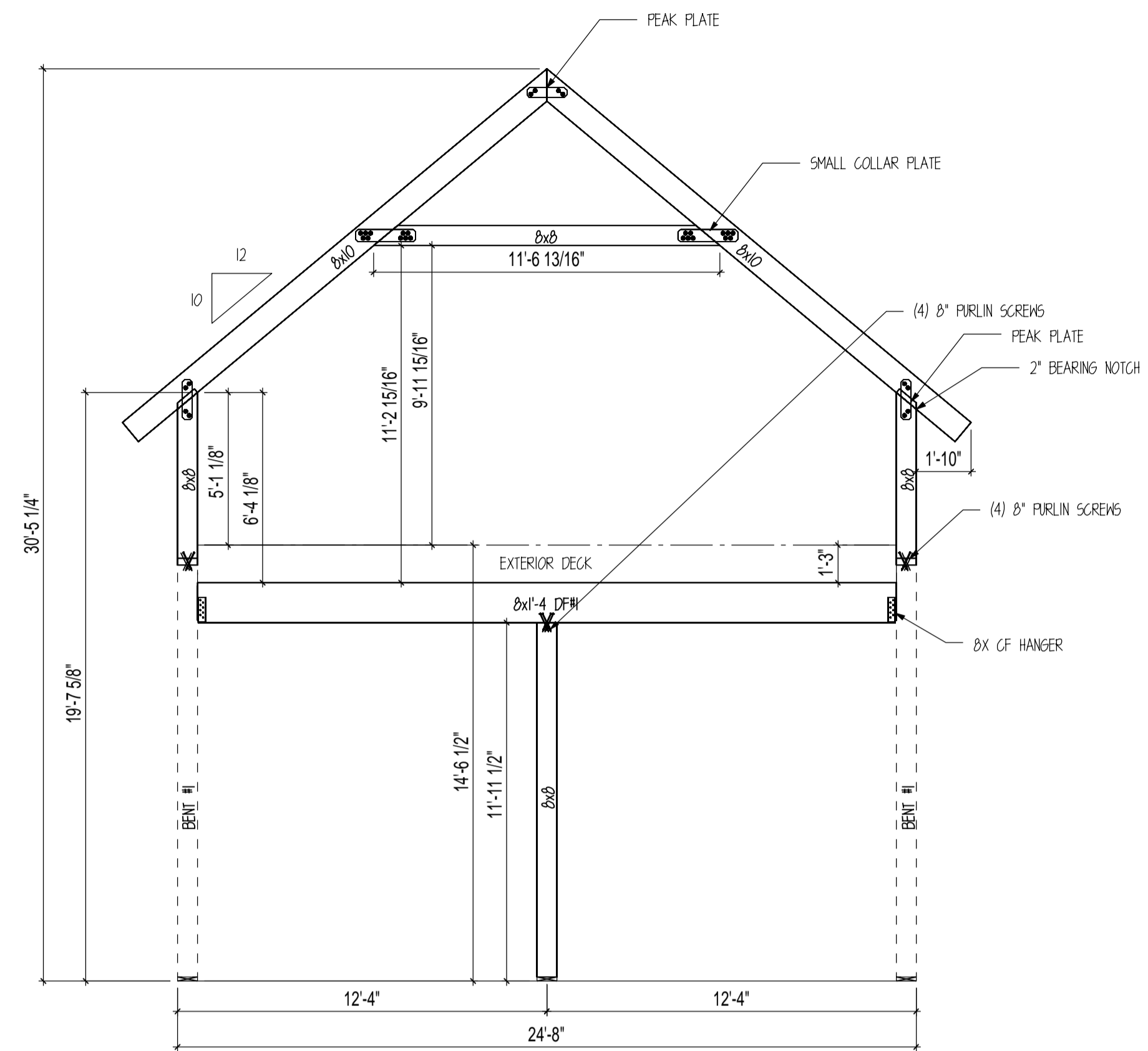

*** MATERIALS CUT
AND BUILT ON SITE ***

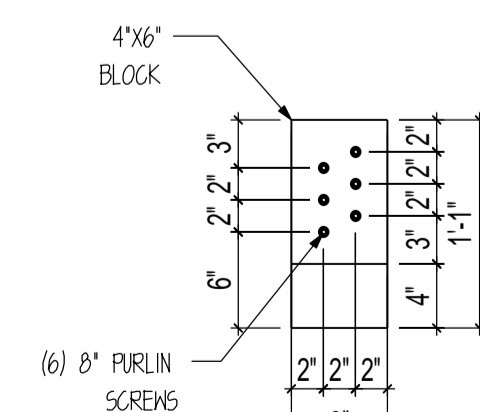

*** MATERIALS CUT
AND BUILT ON SITE ***

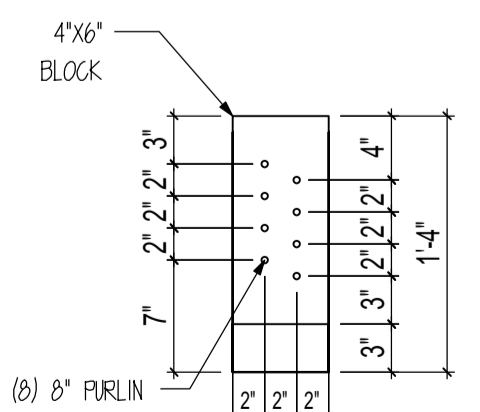

*** MATERIALS CUT
AND BUILT ON SITE ***

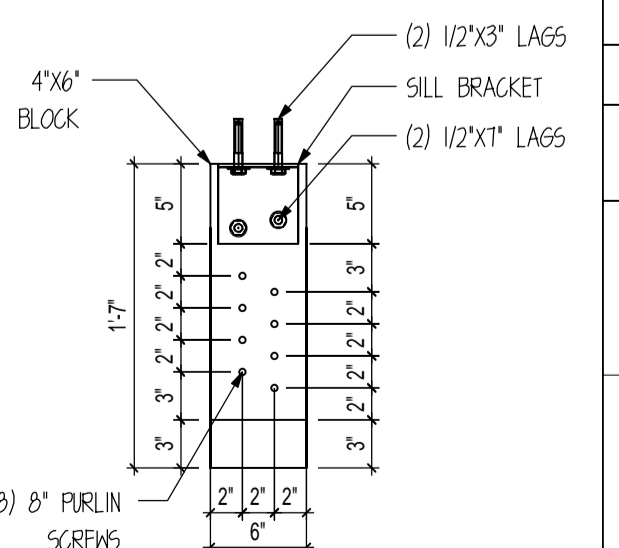

*** MATERIALS CUT
AND BUILT ON SITE ***

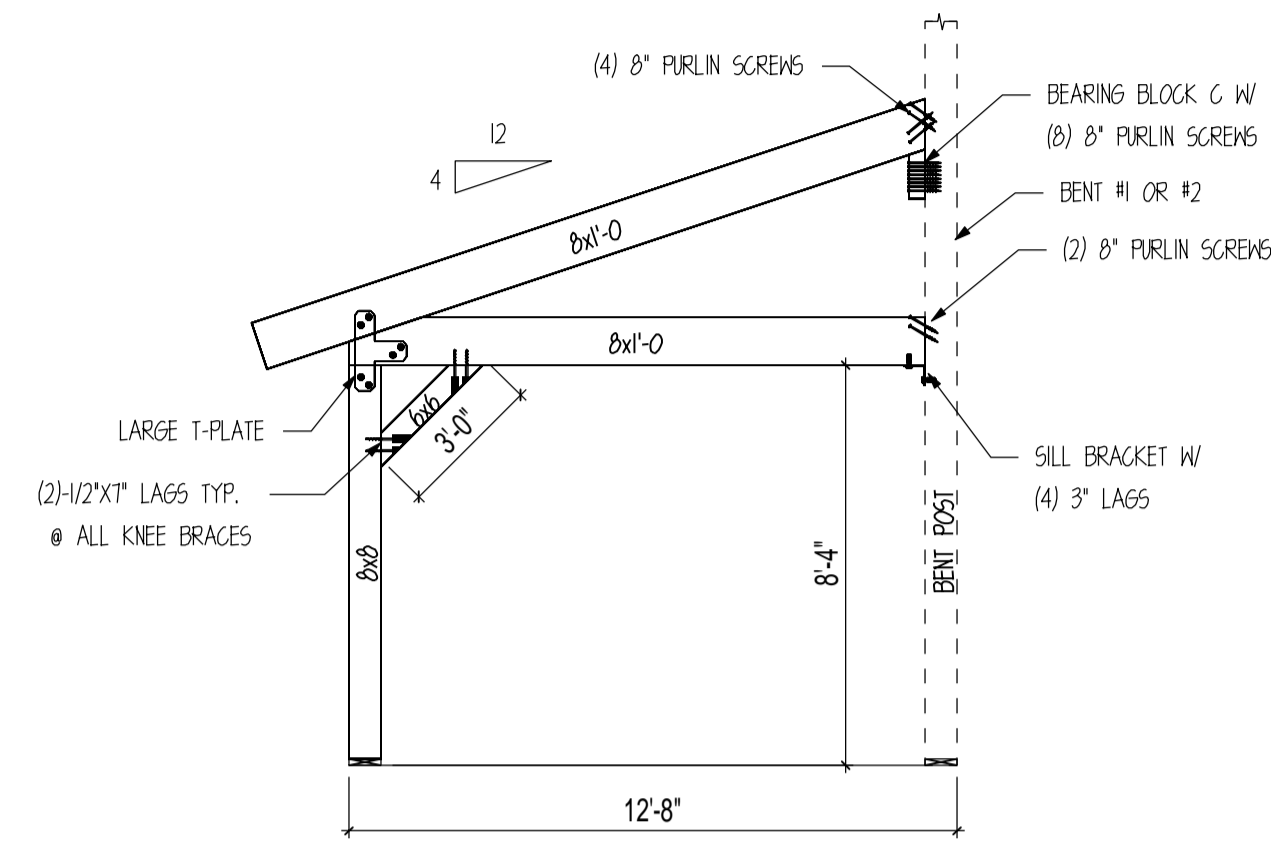

BENT #5
SCALE: 1/4" = 1'

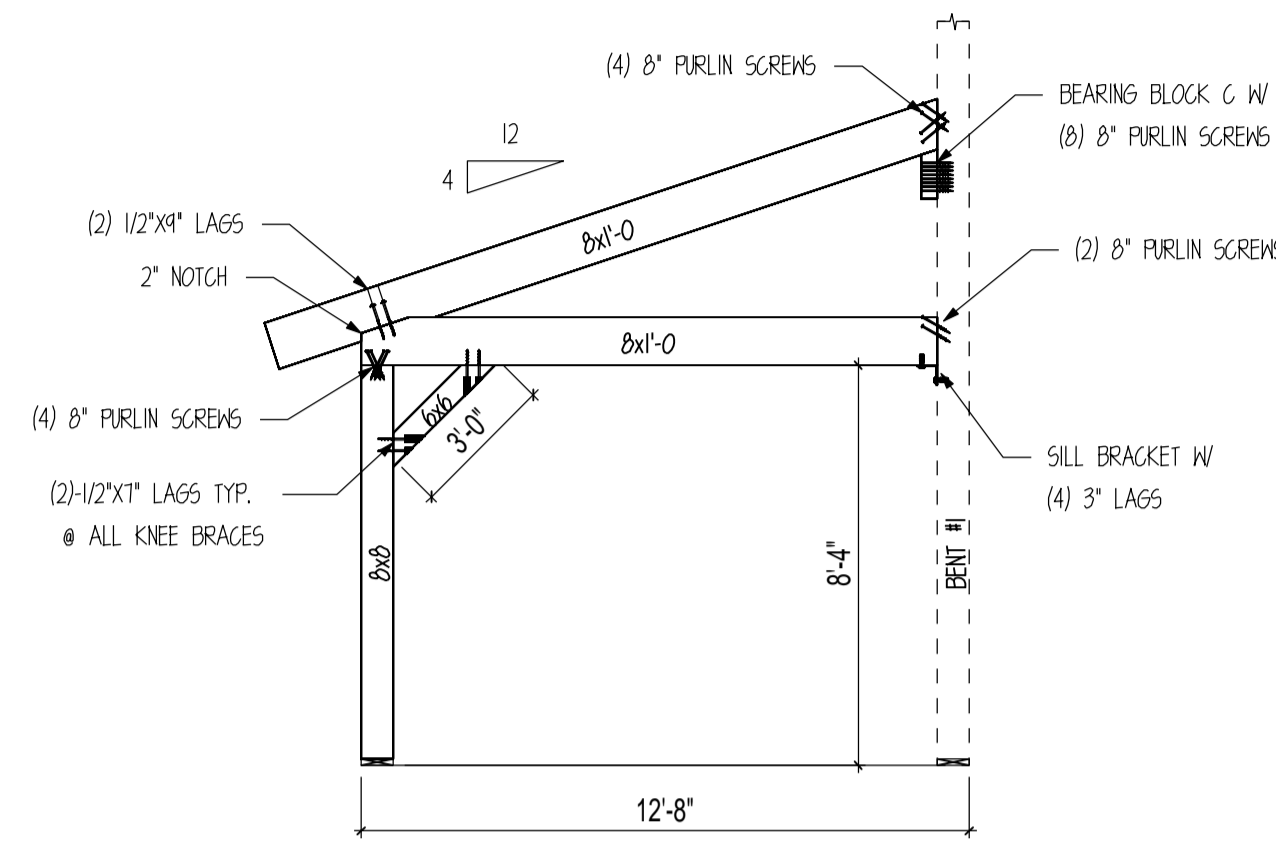

BENT #6
SCALE: 1/4" = 1'

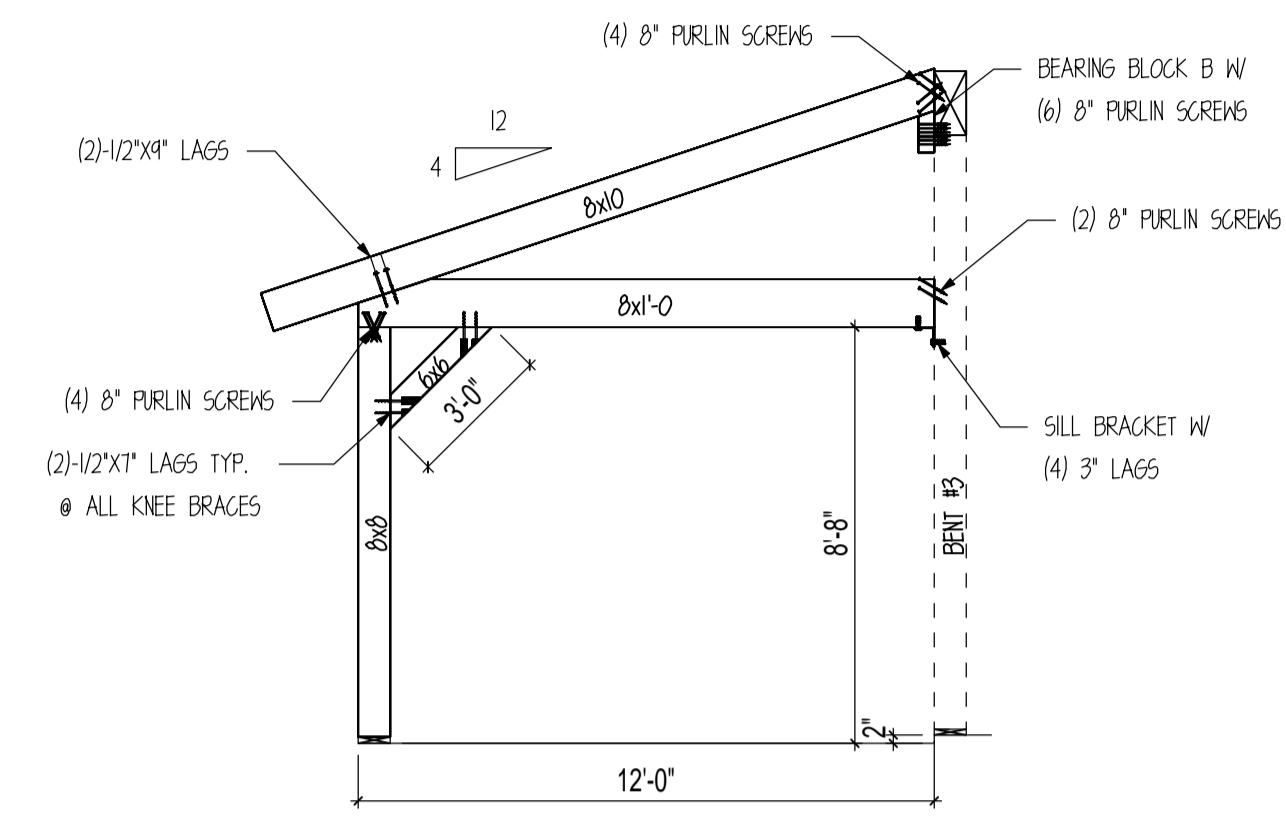

BENT #7
SCALE: 1/4" = 1'

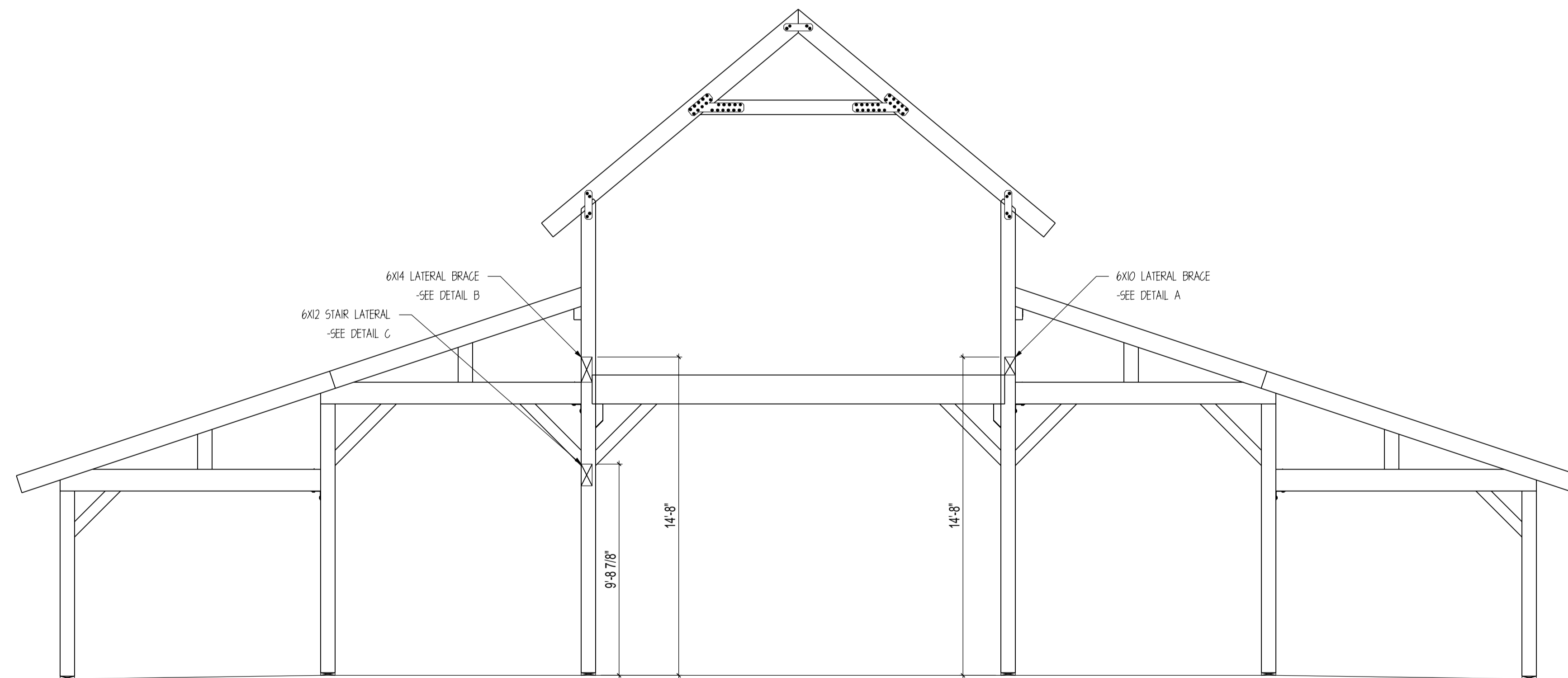

LATERAL BRACE LOCATION
SCALE: 1/4" = 1'

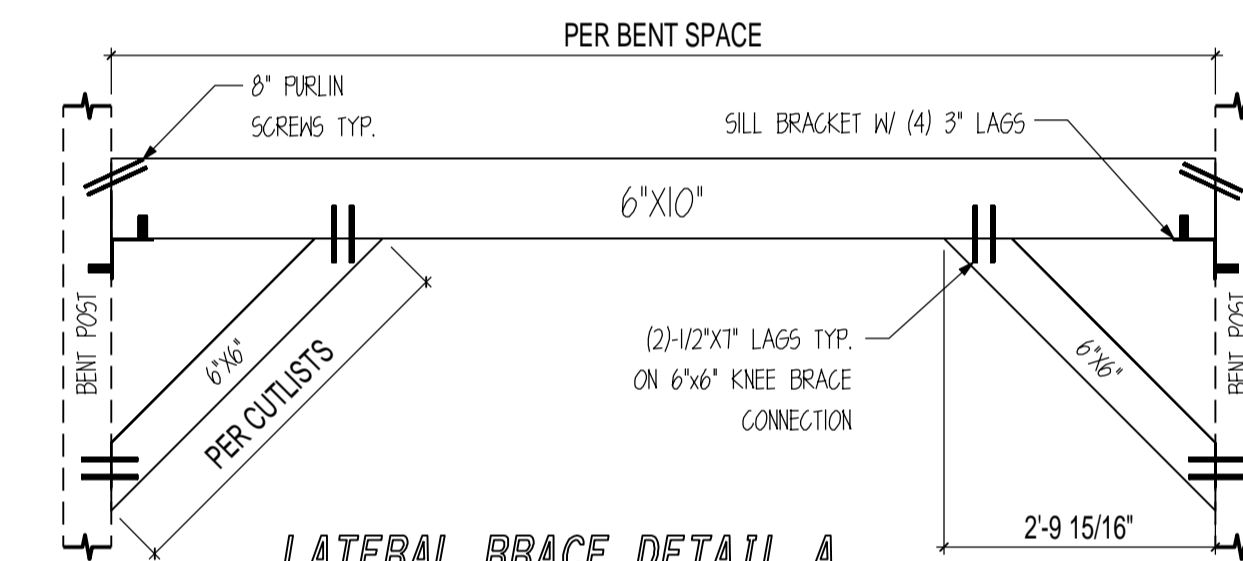

LATERAL BRACE DETAIL A
SCALE: 1/2" = 1'

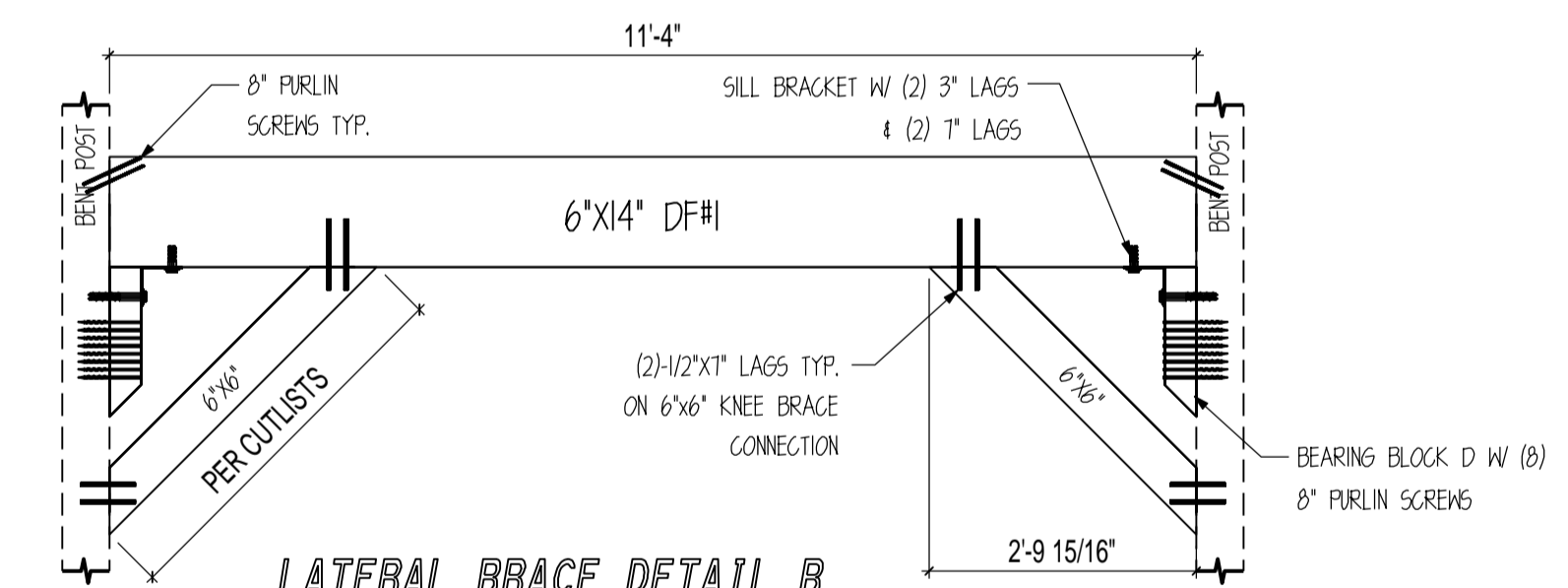

LATERAL BRACE DETAIL B
SCALE: 1/2" = 1'

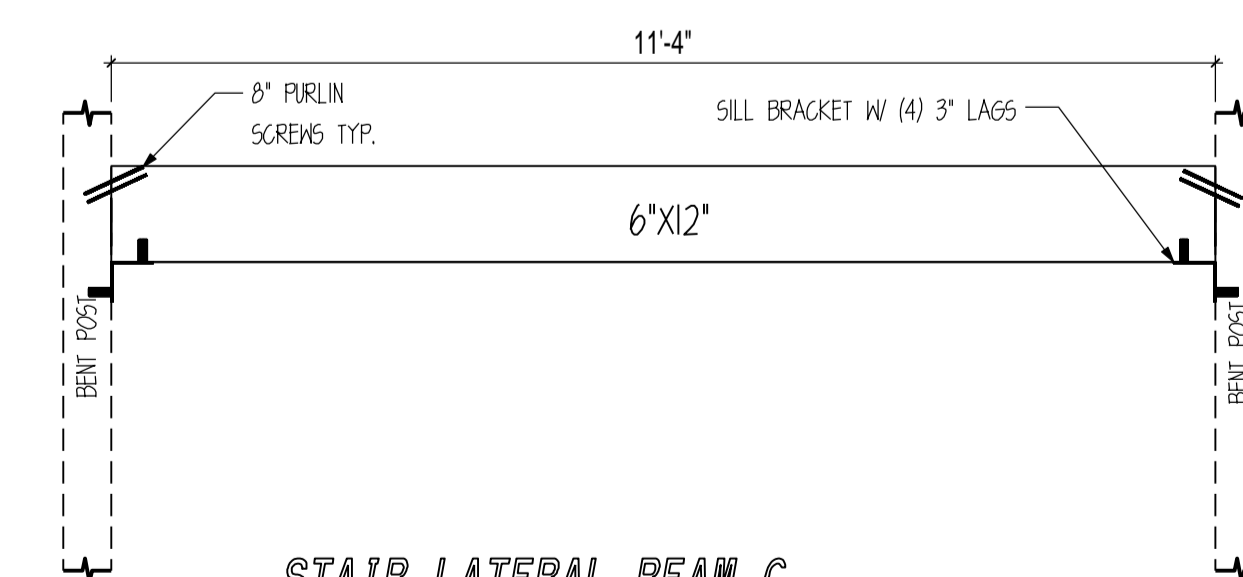

STAIR LATERAL BEAM C
SCALE: 1/2" = 1'

CUSTOMER INFORMATION:

PENDER
SPORTS COMPLEX

PROJECT INFORMATION:

PENDER
COMPLEX
100 SLAUGHTER
PENDER, NE 68047
NUMBER: JGE1122-1 PSC
CATEGORY: COMMERCIAL
STYLE: GREAT PLAINS WESTERN
OTHER: --
OTHER: --
PM: --

DRAWING INFORMATION:

DRAWN BY: BJ
DATE: 09/13/2023
STATUS: FINAL PLAN SET
OTHER: --
OTHER: --

SHEET NOTES

1. BASE OF MAIN FRAME POST CUT TO FIT IN FIELD BY GENERAL CONTRACTOR ACCORDING TO SPECS ON CUT LISTS. CUT BOTTOM OF POST ONLY.

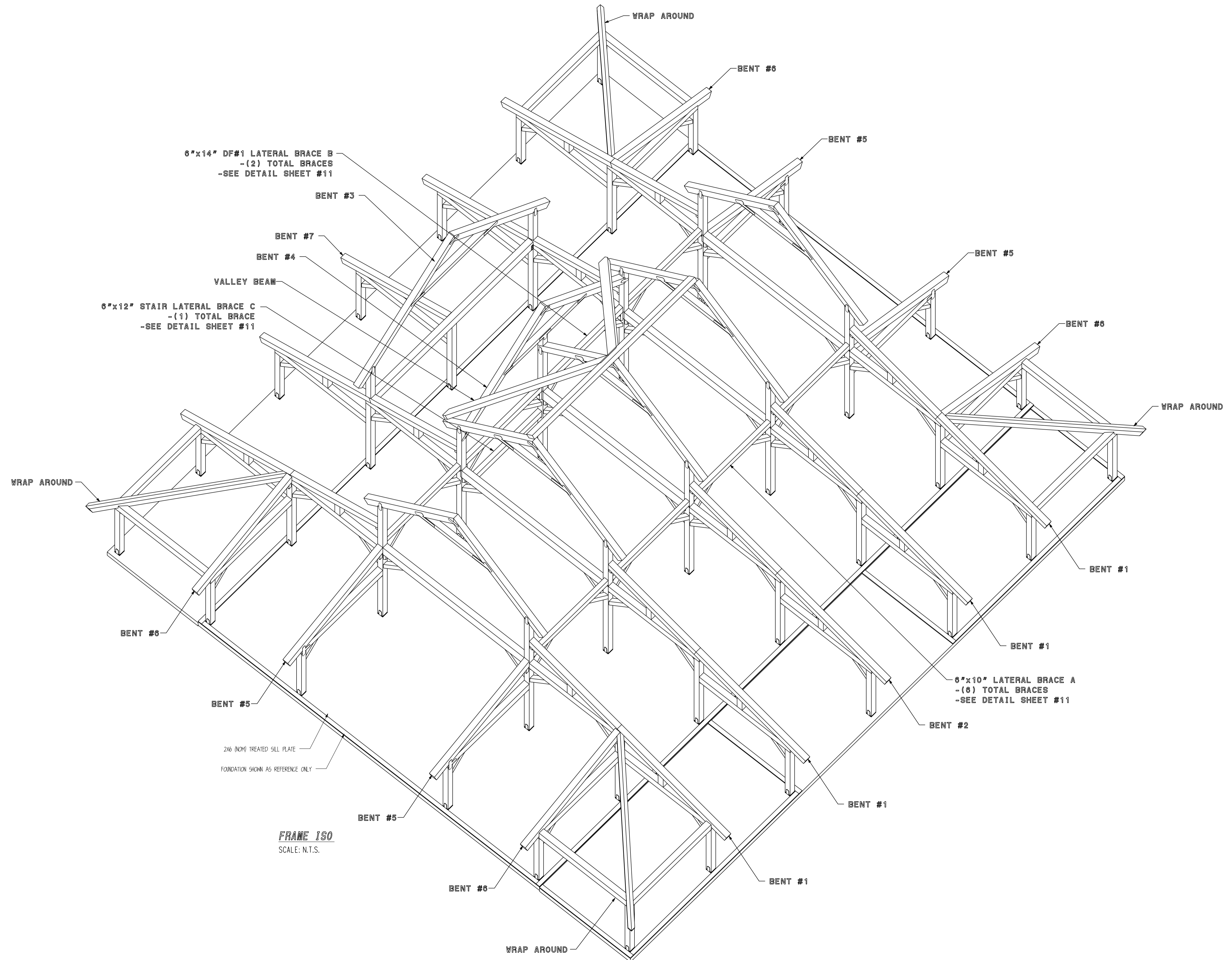

FRAME ISO
SCALE: N.T.S.

CUSTOMER INFORMATION:

PENDER
SPORTS COMPLEX

PROJECT INFORMATION:

PENDER
COMPLEX
100 SLAUGHTER
PENDER, NE 68047
NUMBER: JGE1122-1 PSC
CATEGORY: COMMERCIAL
STYLE: GREAT PLAINS WESTERN
OTHER: --
OTHER: --
PM: --

DRAWING INFORMATION:

DRAWN BY: BJ
DATE: 09/13/2023
STATUS: FINAL PLAN SET
OTHER: --
OTHER: --

SHEET NOTES

1. BASE OF MAIN FRAME POST CUT TO FIT IN
FIELD BY GENERAL CONTRACTOR ACCORDING
TO SPECS ON CUT LISTS. CUT BOTTOM OF
POST ONLY.

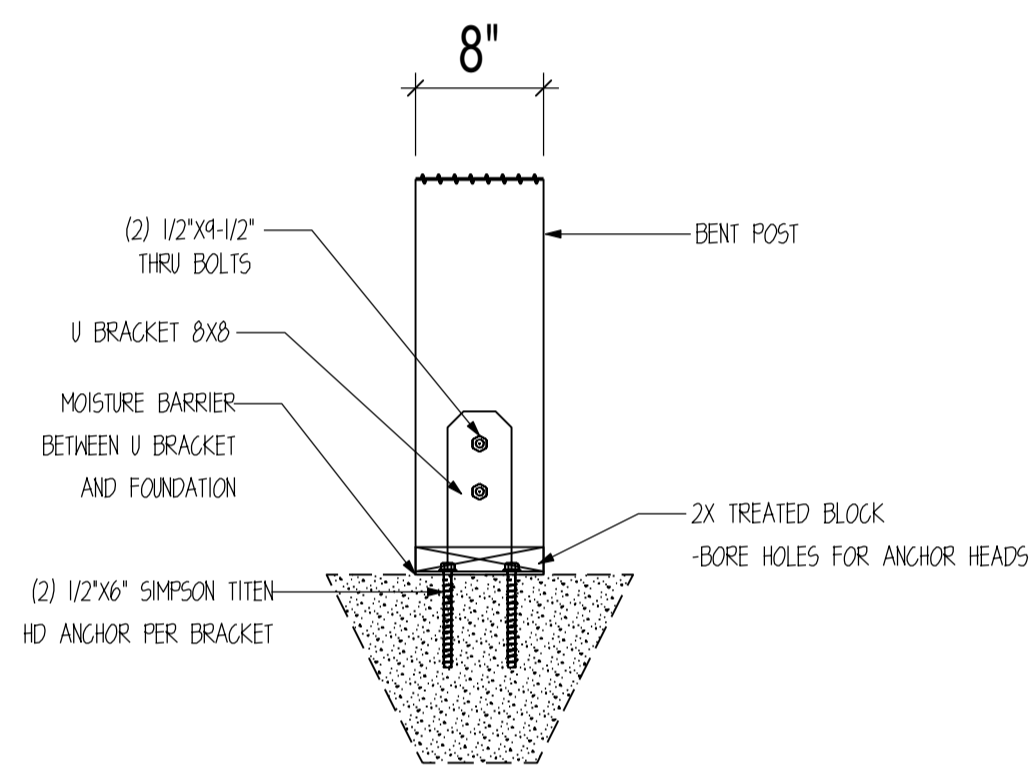
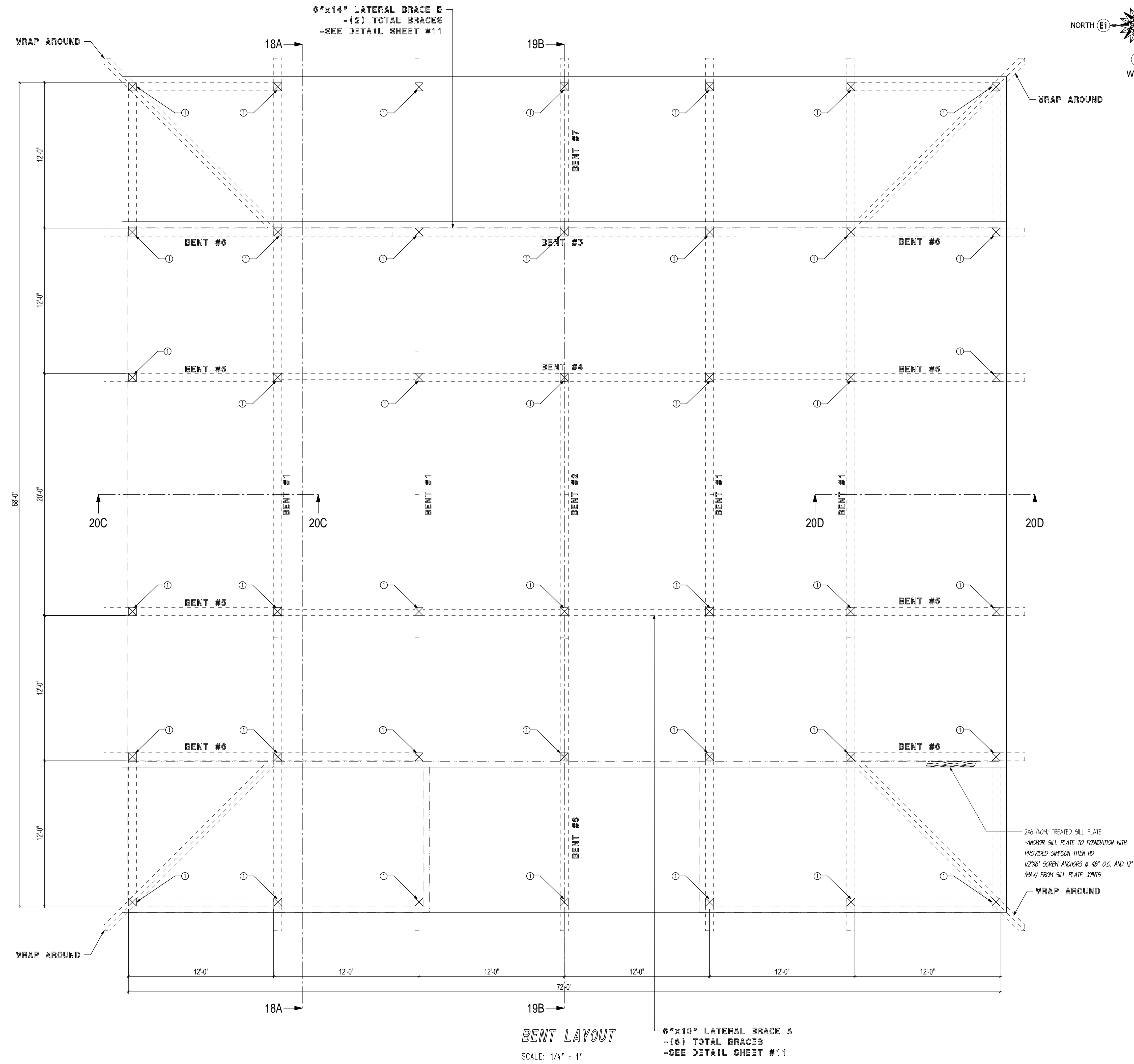
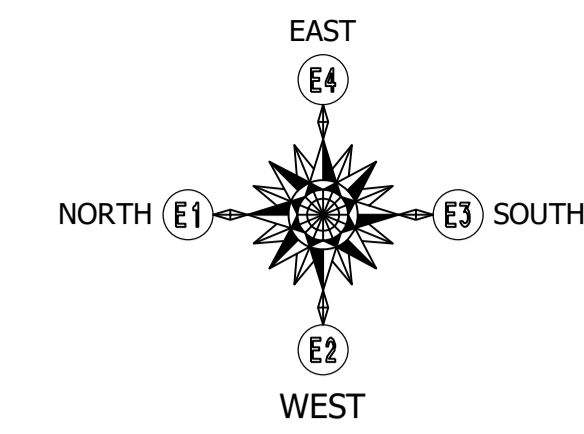

1 POST CONNECTION DETAIL
SCALE: 1" = 1'-0"

CUSTOMER INFORMATION:
PENDER
SPORTS COMPLEX

PROJECT INFORMATION:
PENDER
COMPLEX
100 SLAUGHTER
PENDER, NE 68047
NUMBER: JGE1122-1 PSC
CATEGORY: COMMERCIAL
STYLE: GREAT PLAINS WESTERN
OTHER: --
OTHER: --
PM: --

DRAWING INFORMATION:
DRAWN BY: BJ
DATE: 09/13/2023
STATUS: FINAL PLAN SET
OTHER: --
OTHER: --

SHEET NOTES
1. BASE OF MAIN FRAME POST CUT TO FIT IN FIELD BY GENERAL CONTRACTOR ACCORDING TO SPECS ON CUT LISTS. CUT BOTTOM OF POST ONLY.

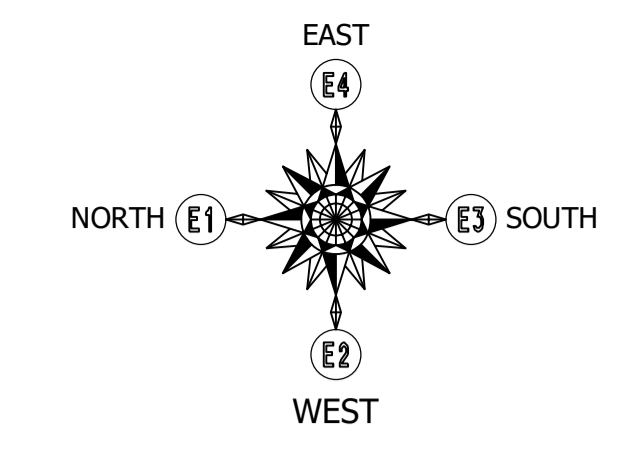

© 2021 Timberlyne. All Rights Reserved.
 THIS PLAN AND DESIGNS CONTAINED HEREIN ARE THE
 PROPERTY OF TIMBERLYNE GROUP™ AND MAY NOT BE
 REPRODUCED WITHOUT PRIOR WRITTEN CONSENT FROM
 TIMBERLYNE GROUP™.

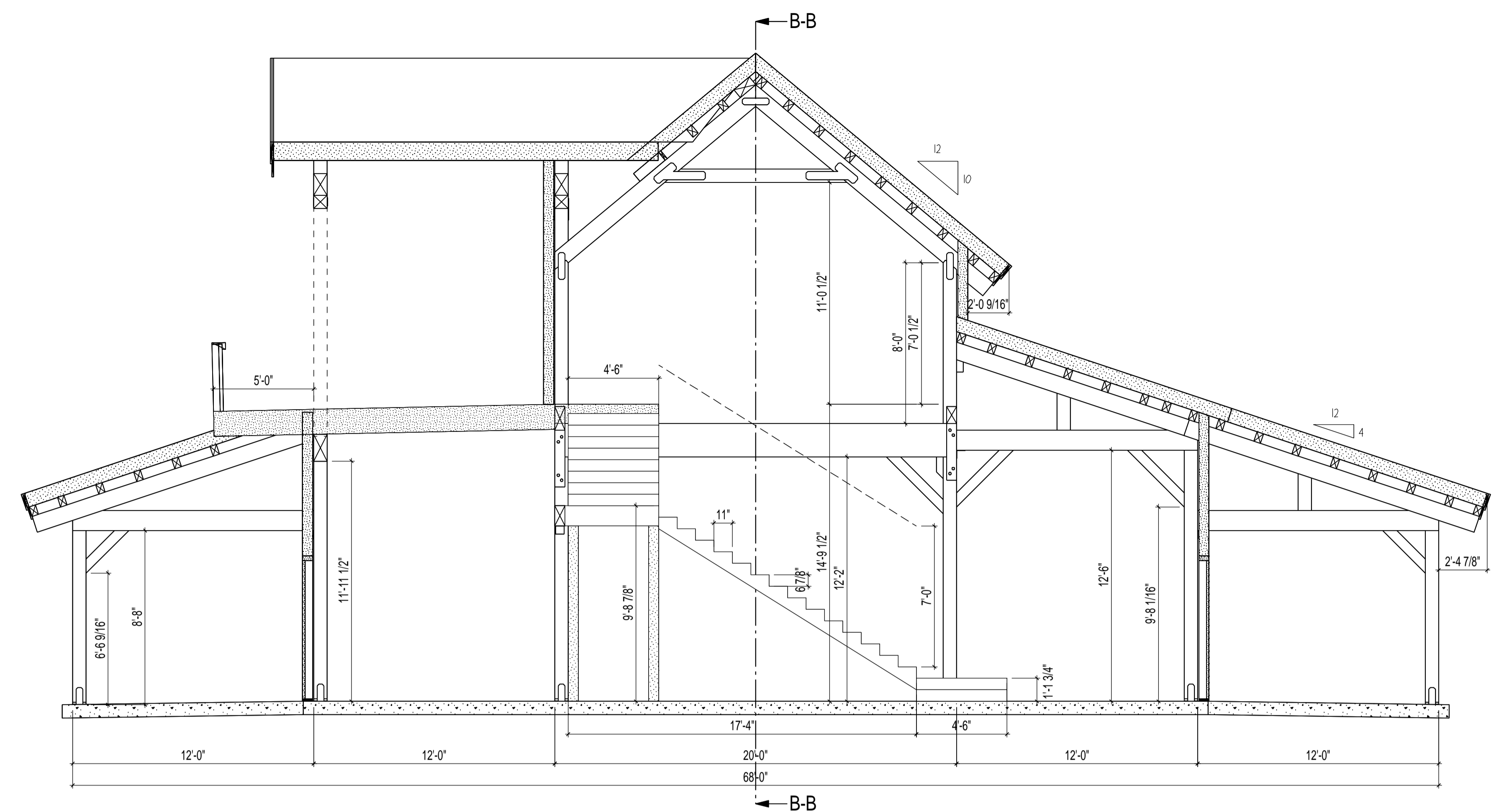

BUILDING SECTION A-A
 SCALE: 1/4" = 1'

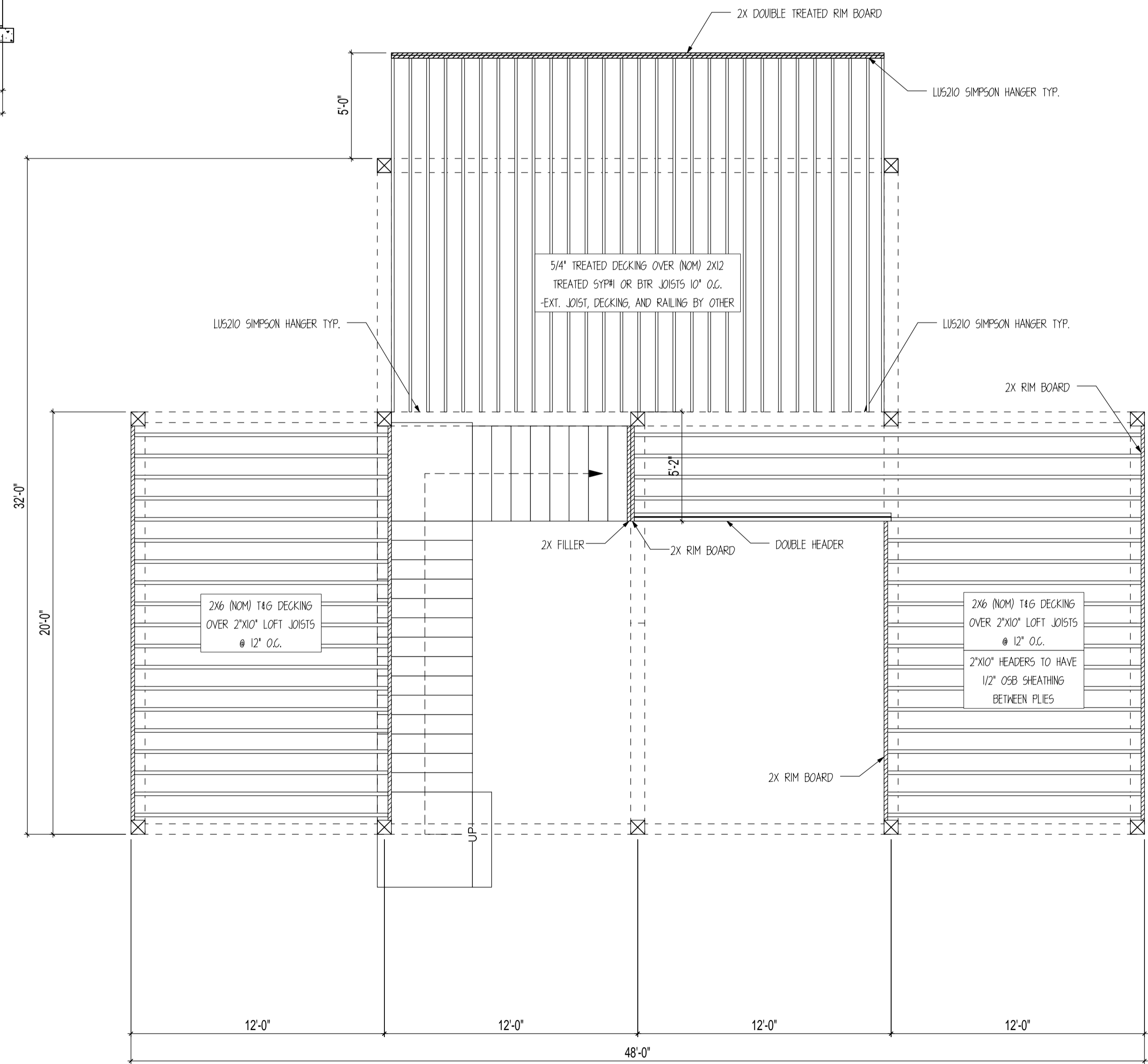

LOFT FRAMING PLAN
 SCALE: 1/4" = 1'

CUSTOMER INFORMATION:
PENDER
 SPORTS COMPLEX

PROJECT INFORMATION:
PENDER
COMPLEX
 100 SLAUGHTER
 PENDER, NE 68047
 NUMBER: JGE1122-1 PSC
 CATEGORY: COMMERCIAL
 STYLE: GREAT PLAINS WESTERN
 OTHER: --
 OTHER: --
 PM: --

DRAWING INFORMATION:
 DRAWN BY: BJ
 DATE: 09/13/2023
 STATUS: FINAL PLAN SET
 OTHER: --
 OTHER: --

SHEET NOTES
 1. INSTALL BLOCKING BETWEEN JOISTS @ ALL ENDS.
 2. ALL HANGERS SUPPLIED BY OTHER

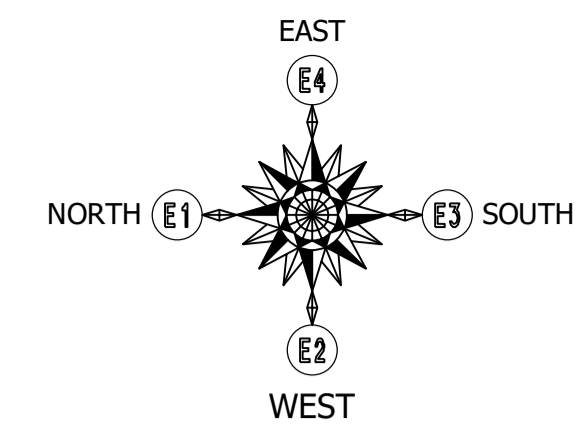

© 2021 Timberlyne. All Rights Reserved.
THIS PLAN AND DESIGNS CONTAINED HEREIN ARE THE
PROPERTY OF TIMBERLYNE GROUP™ AND MAY NOT BE
REPRODUCED WITHOUT PRIOR WRITTEN CONSENT FROM
TIMBERLYNE GROUP™.

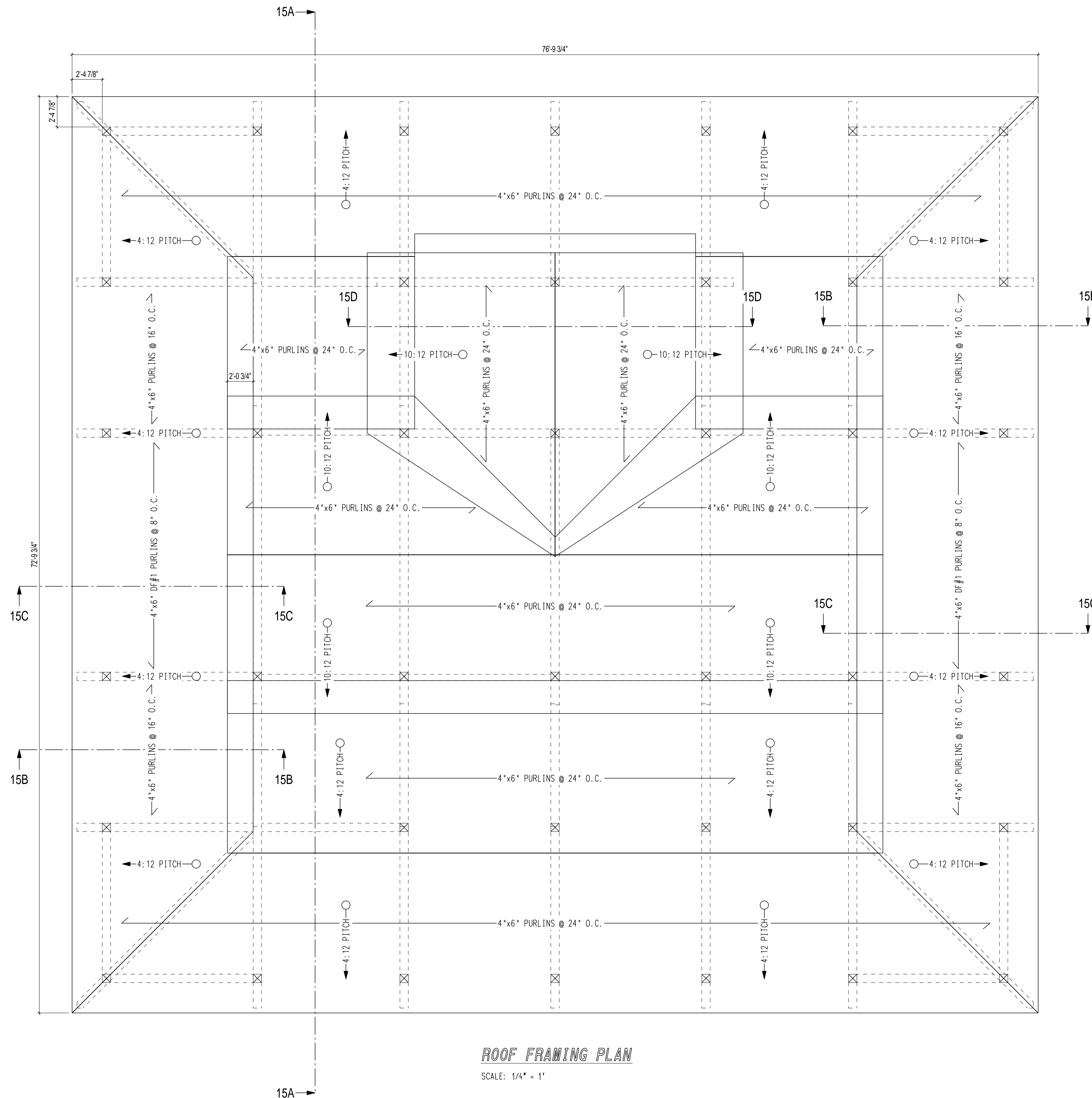

ROOF FRAMING PLAN
SCALE: 1/4" = 1'

CUSTOMER INFORMATION:
PENDER
SPORTS COMPLEX

PROJECT INFORMATION:
PENDER
COMPLEX
100 SLAUGHTER
PENDER, NE 68047
NUMBER: JGE1122-1 PSC
CATEGORY: COMMERCIAL
STYLE: GREAT PLAINS WESTERN
OTHER: --
OTHER: --
PM: --

DRAWING INFORMATION:
DRAWN BY: BJ
DATE: 09/13/2023
STATUS: FINAL PLAN SET
OTHER: --
OTHER: --

SHEET NOTES
1. SEE SIP MANUFACTURE DRAWING FOR PANEL
INSTALLATION

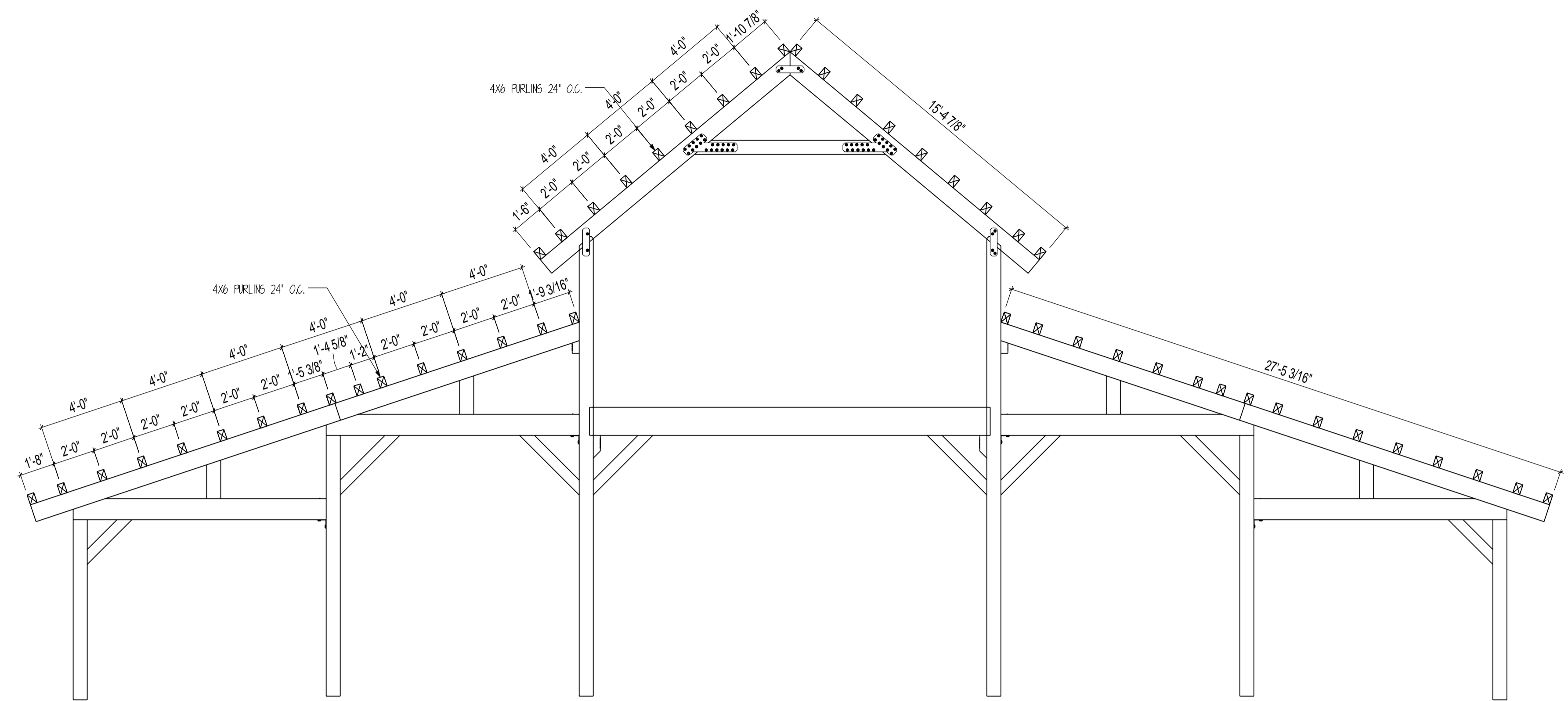

PURLIN LAYOUT A

SCALE: 1/4" = 1'

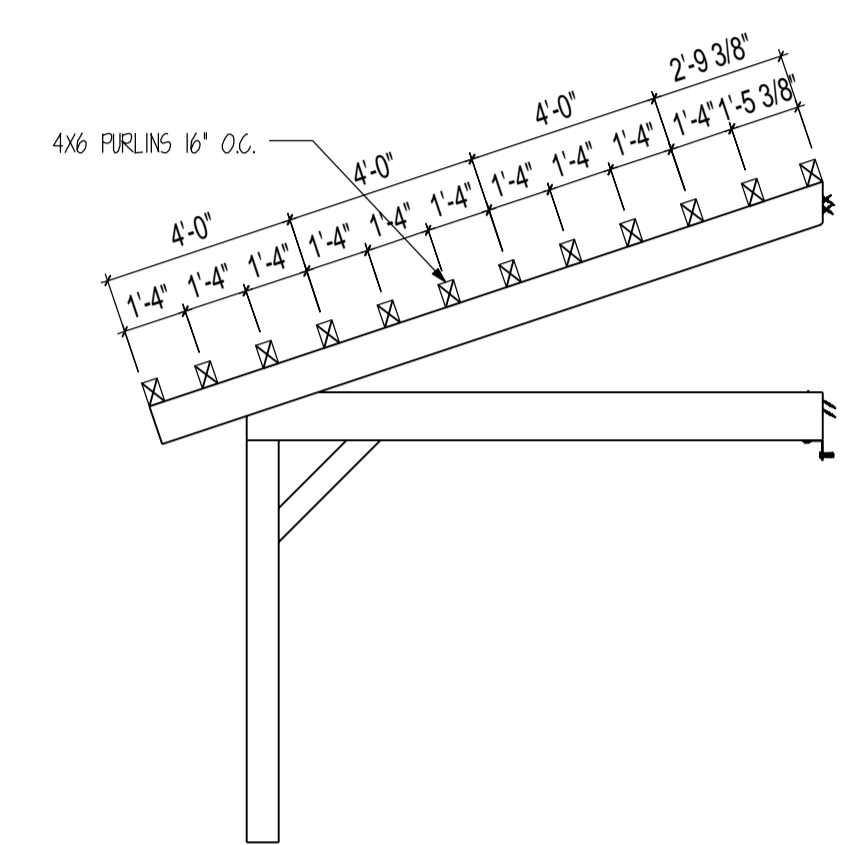

PURLIN LAYOUT B

SCALE: 1/4" = 1'

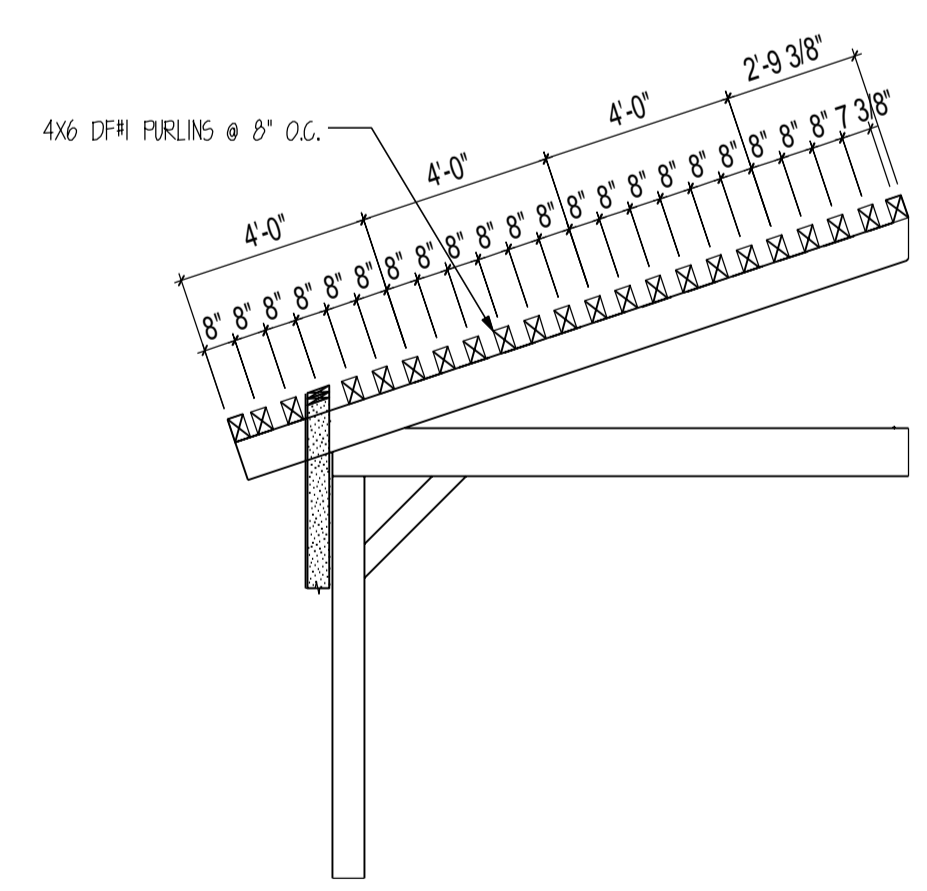

PURLIN LAYOUT C

SCALE: 1/4" = 1'

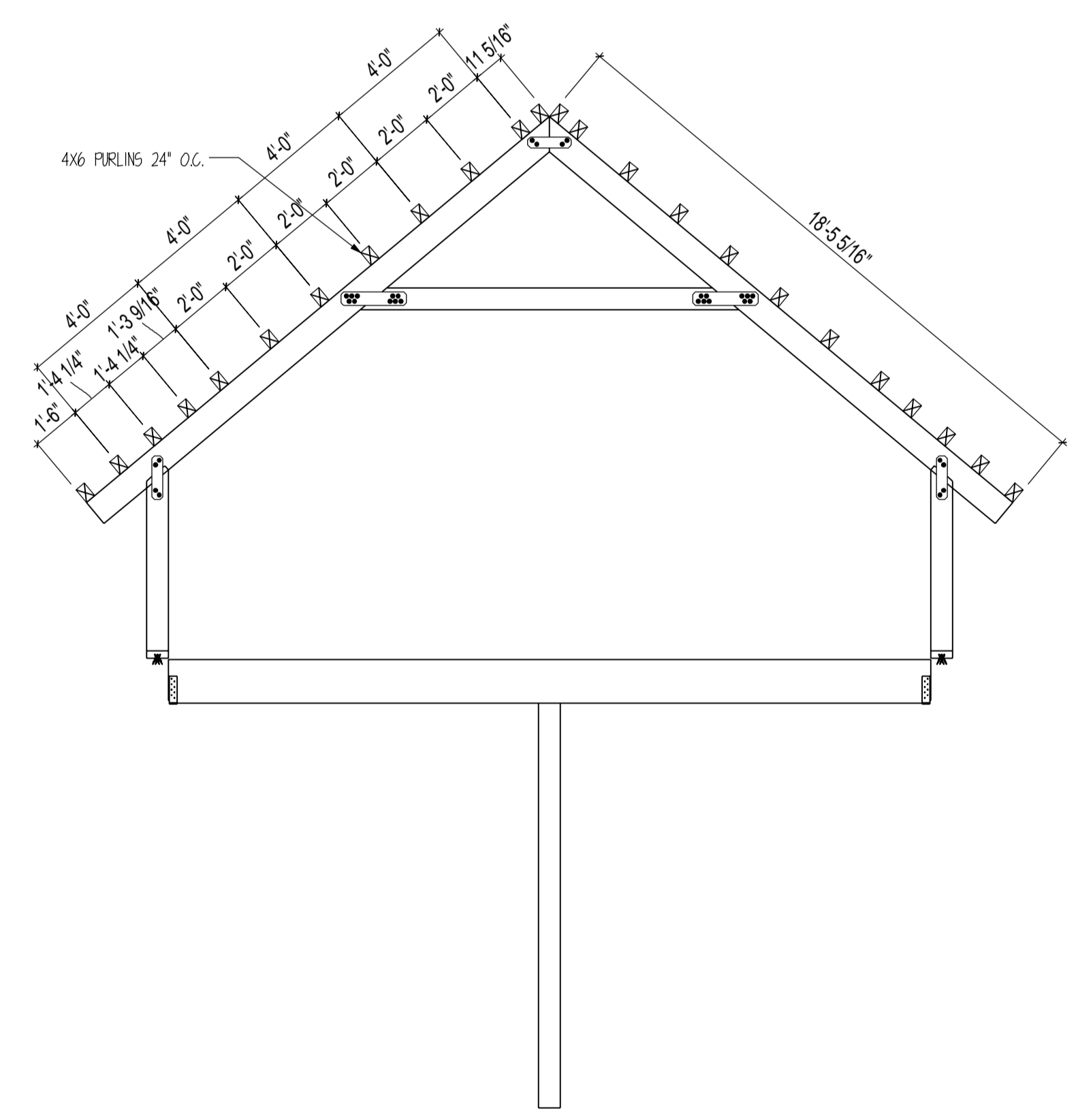

PURLIN LAYOUT D

SCALE: 1/4" = 1'

CUSTOMER INFORMATION:

PENDER

SPORTS COMPLEX

PROJECT INFORMATION:

PENDER

COMPLEX

100 SLAUGHTER
PENDER, NE 68047

NUMBER: JGE1122-1 PSC

CATEGORY: COMMERCIAL

STYLE: GREAT PLAINS WESTERN

OTHER: --

OTHER: --

PM: --

DRAWING INFORMATION:

DRAWN BY: BJ

DATE: 09/13/2023

STATUS: FINAL PLAN SET

OTHER: --

OTHER: --

SHEET NOTES

1. SEE SIP MANUFACTURE DRAWING FOR PANEL
INSTALLATION

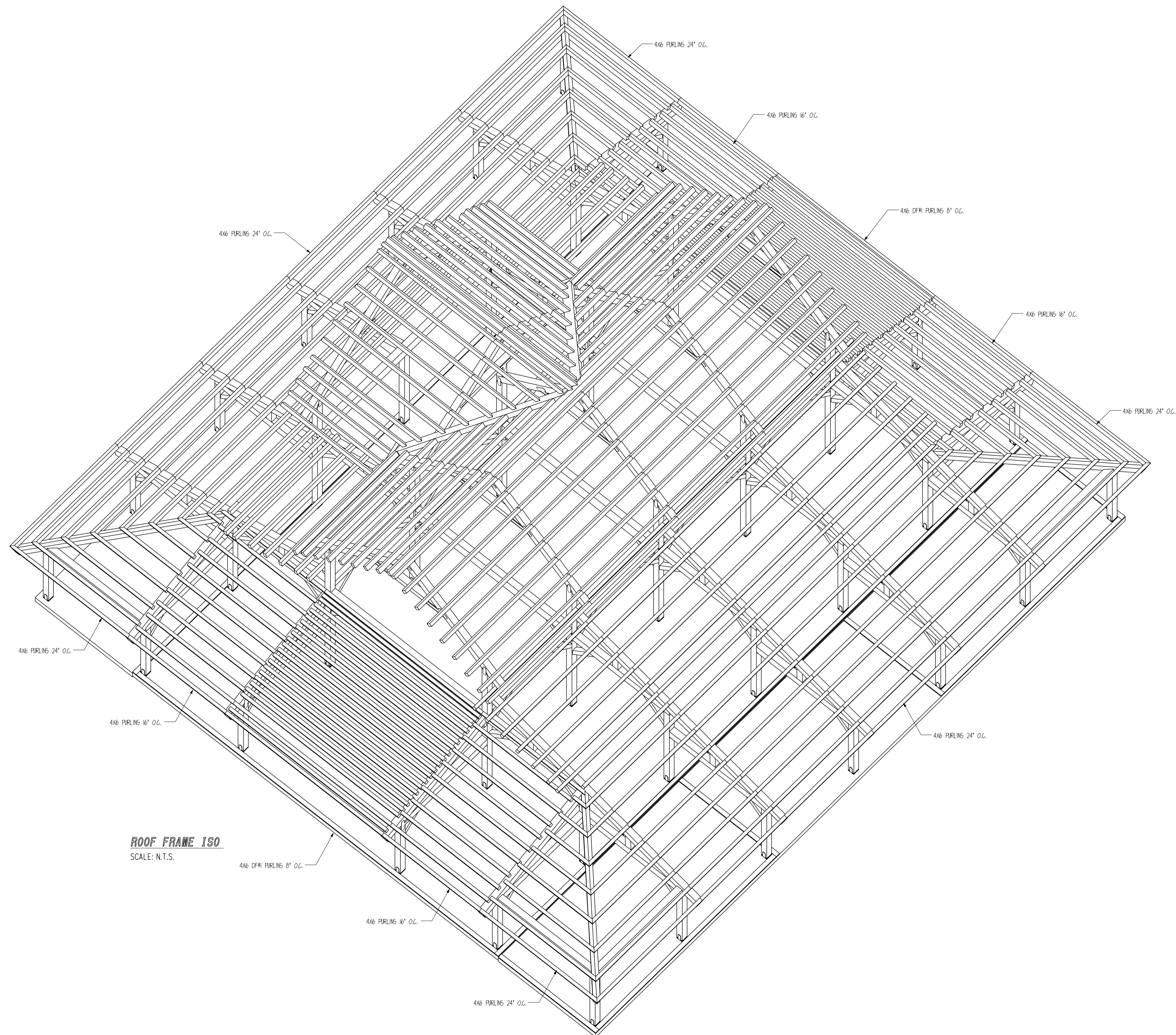

ROOF FRAME ISO
SCALE: N.T.S.

CUSTOMER INFORMATION:

PENDER
SPORTS COMPLEX

PROJECT INFORMATION:

PENDER
COMPLEX
100 SLAUGHTER
PENDER, NE 68047
NUMBER: JGE1122-1 PSC
CATEGORY: COMMERCIAL
STYLE: GREAT PLAINS WESTERN
OTHER: --
OTHER: --
PM: --

DRAWING INFORMATION:

DRAWN BY: BJ
DATE: 09/13/2023
STATUS: FINAL PLAN SET
OTHER: --
OTHER: --

SHEET NOTES
1. SEE SIP MANUFACTURE DRAWING FOR PANEL
INSTALLATION

NOTE: EXTERIOR FLASHING TO BE
 INSTALLED AT ALL CONNECTIONS
 BETWEEN ROOFS, WALLS, AND
 PROJECTIONS OR PENETRATIONS
 AS REQUIRED BY GOOD
 CONSTRUCTION PRACTICES.
 FLASHING MATERIALS AND
 DETAILS TO BE PROVIDED BY
 CUSTOMER OR GENERAL
 CONTRACTOR.

NOTE: ALL OSB
 SHEATHING TO BE APA
 RATED SHEATHING W/
 SPAN RATING OF
 32/16 INSTALLED
 PERP. TO SUPPORTS

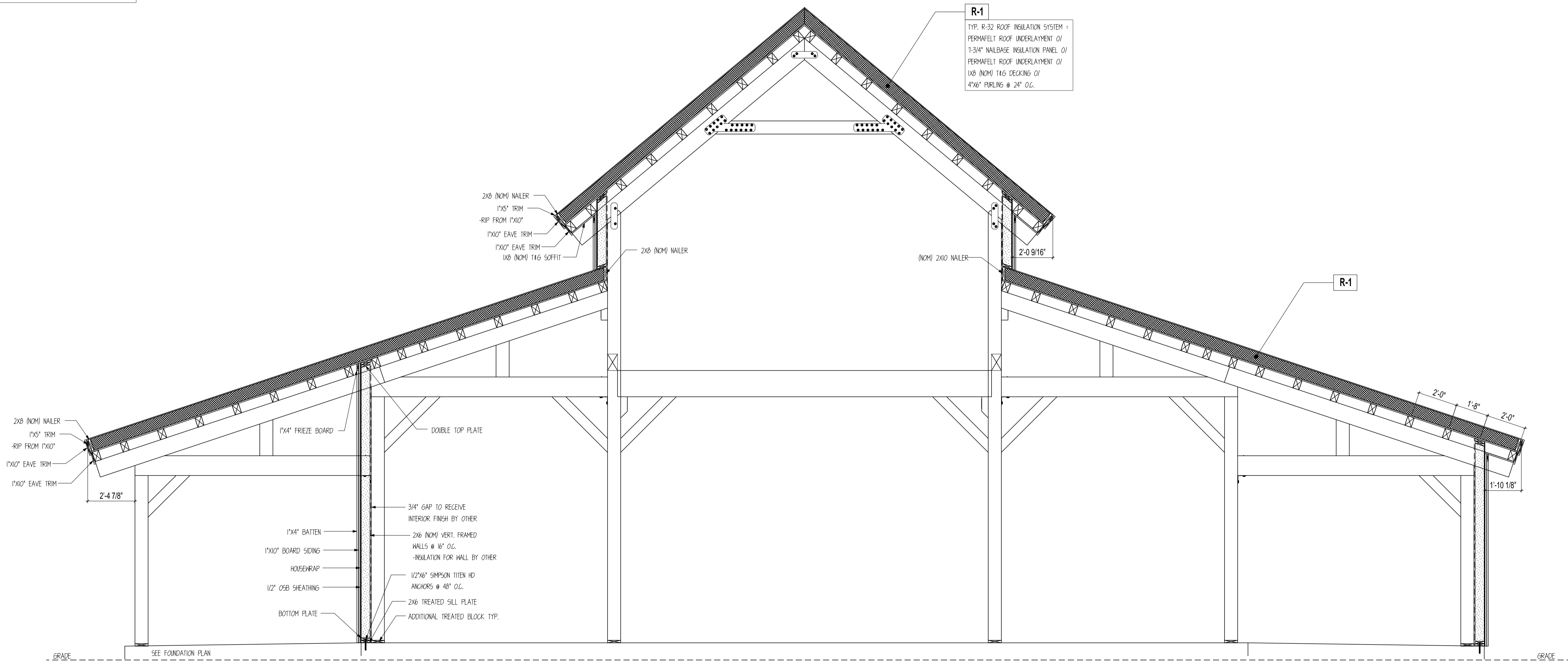

R-1
 TYP. R-32 ROOF INSULATION SYSTEM :
 PERMAFELT ROOF UNDERLAYMENT O/
 1-3/4\"/>

A FULL BUILDING SECTION
 SCALE : 3/8" = 1'

CUSTOMER INFORMATION:
PENDER
 SPORTS COMPLEX

PROJECT INFORMATION:
PENDER
COMPLEX
 100 SLAUGHTER
 PENDER, NE 68047
 NUMBER: JGE1122-1 PSC
 CATEGORY: COMMERCIAL
 STYLE: GREAT PLAINS WESTERN
 OTHER: --
 OTHER: --
 PM: --

DRAWING INFORMATION:
 DRAWN BY: BJ
 DATE: 09/13/2023
 STATUS: FINAL PLAN SET
 OTHER: --
 OTHER: --

SHEET NOTES

NOTE: EXTERIOR FLASHING TO BE INSTALLED AT ALL CONNECTIONS BETWEEN ROOFS, WALLS, AND PROJECTIONS OR PENETRATIONS AS REQUIRED BY GOOD CONSTRUCTION PRACTICES. FLASHING MATERIALS AND DETAILS TO BE PROVIDED BY CUSTOMER OR GENERAL CONTRACTOR.

NOTE: ALL OSB SHEATHING TO BE APA RATED SHEATHING W/ SPAN RATING OF 32/16 INSTALLED PERP. TO SUPPORTS

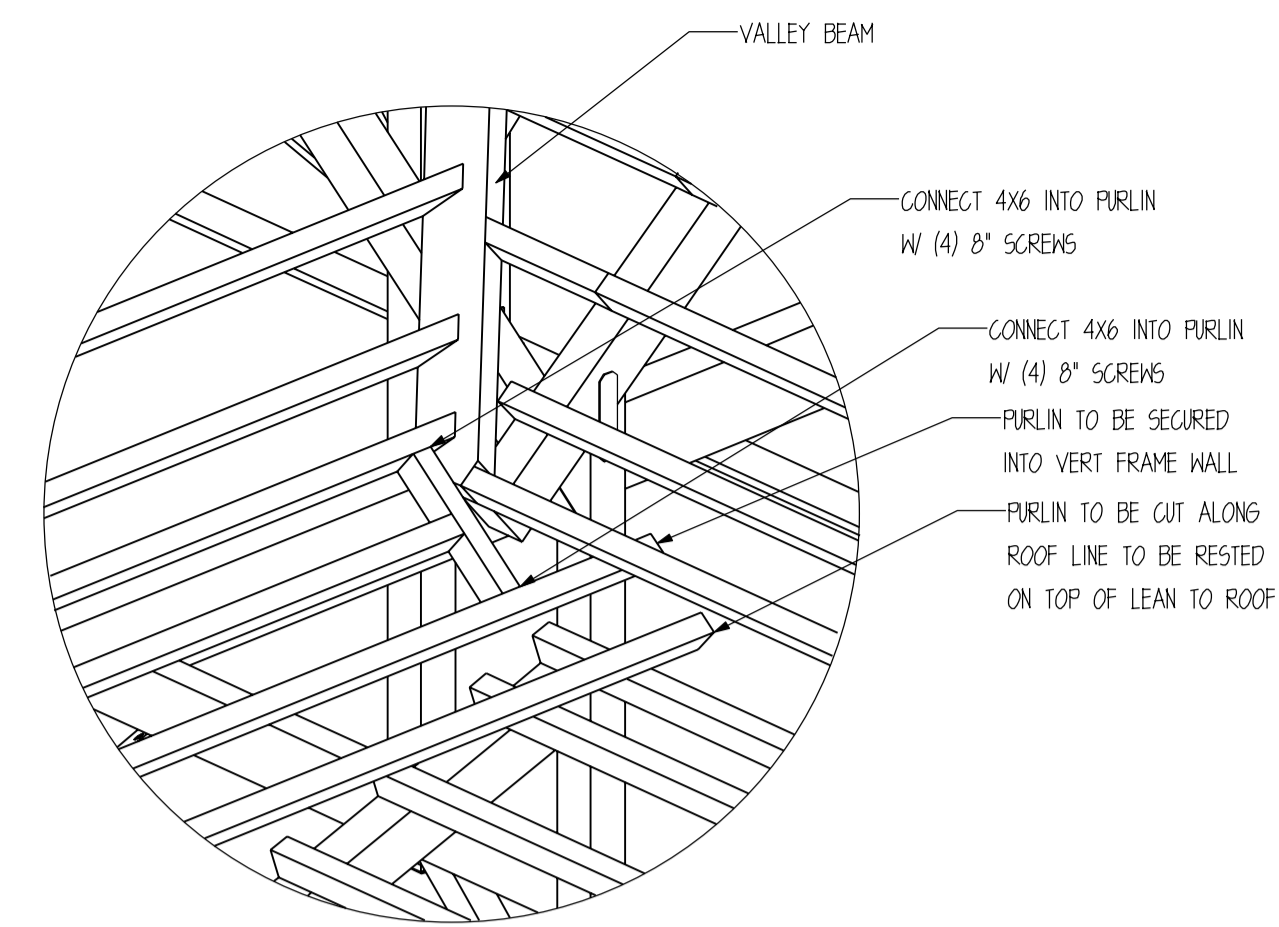

PURLIN ATTACHMENT DETAIL
 SCALE : 3/8" = 1'

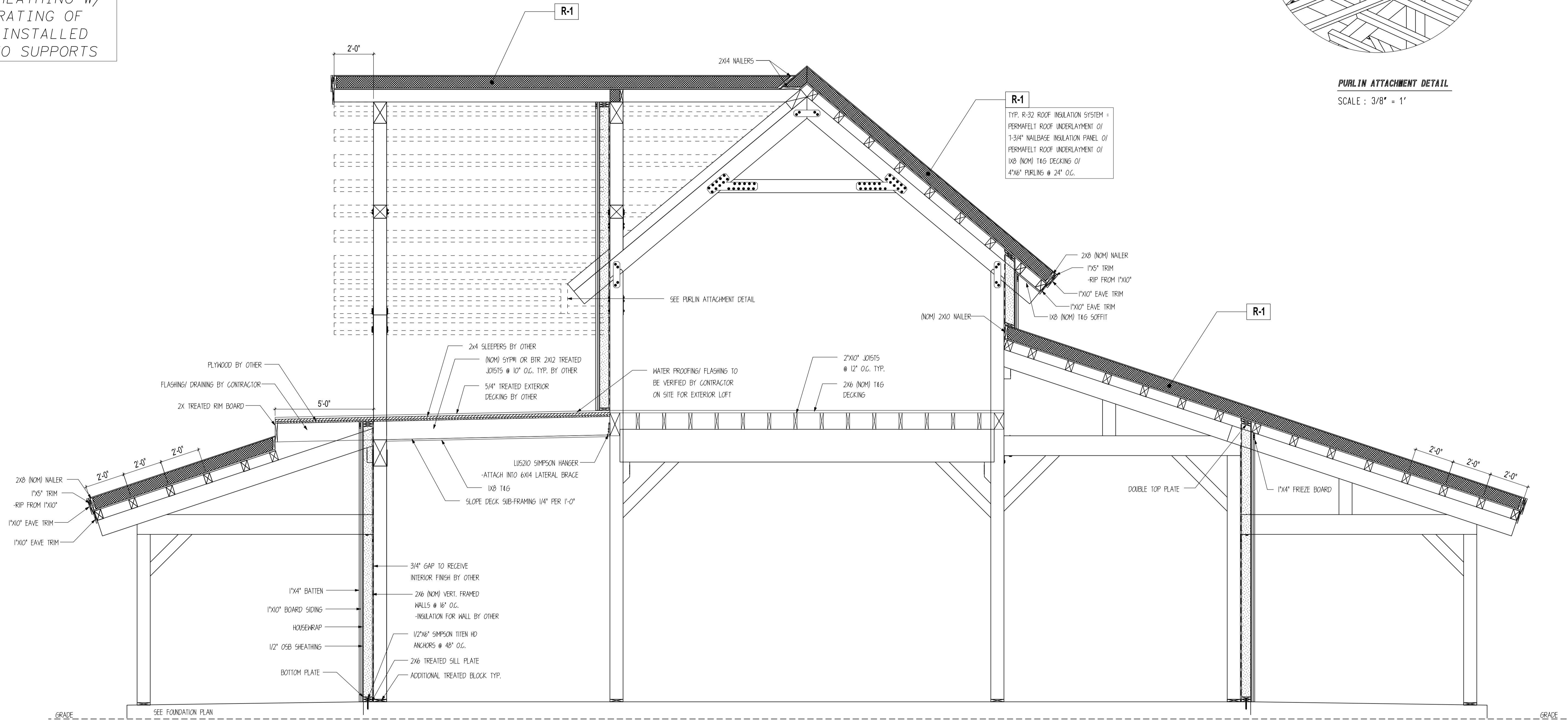

R-1
 TYP. R-32 ROOF INSULATION SYSTEM = PERMAFELT ROOF UNDERLAYMENT O/ 1-3/4" NAILBASE INSULATION PANEL O/ PERMAFELT ROOF UNDERLAYMENT O/ 1x8 (NOM) T&G DECKING O/ 4"x6" PURLINS @ 24" O.C.

B FULL BUILDING SECTION
 SCALE : 3/8" = 1'

CUSTOMER INFORMATION:
PENDER
 SPORTS COMPLEX

PROJECT INFORMATION:
PENDER
COMPLEX
 100 SLAUGHTER
 PENDER, NE 68047
 NUMBER: JGE1122-1 PSC
 CATEGORY: COMMERCIAL
 STYLE: GREAT PLAINS WESTERN
 OTHER: --
 OTHER: --
 PM: --

DRAWING INFORMATION:
 DRAWN BY: BJ
 DATE: 09/13/2023
 STATUS: FINAL PLAN SET
 OTHER: --
 OTHER: --

SHEET NOTES

CUSTOMER INFORMATION:

PENDER
SPORTS COMPLEX

PROJECT INFORMATION:

PENDER
COMPLEX
100 SLAUGHTER
PENDER, NE 68047
NUMBER: JGE1122-1 PSC
CATEGORY: COMMERCIAL
STYLE: GREAT PLAINS WESTERN
OTHER: --
OTHER: --
PM: --

DRAWING INFORMATION:

DRAWN BY: BJ
DATE: 09/13/2023
STATUS: FINAL PLAN SET
OTHER: --
OTHER: --

SHEET NOTES

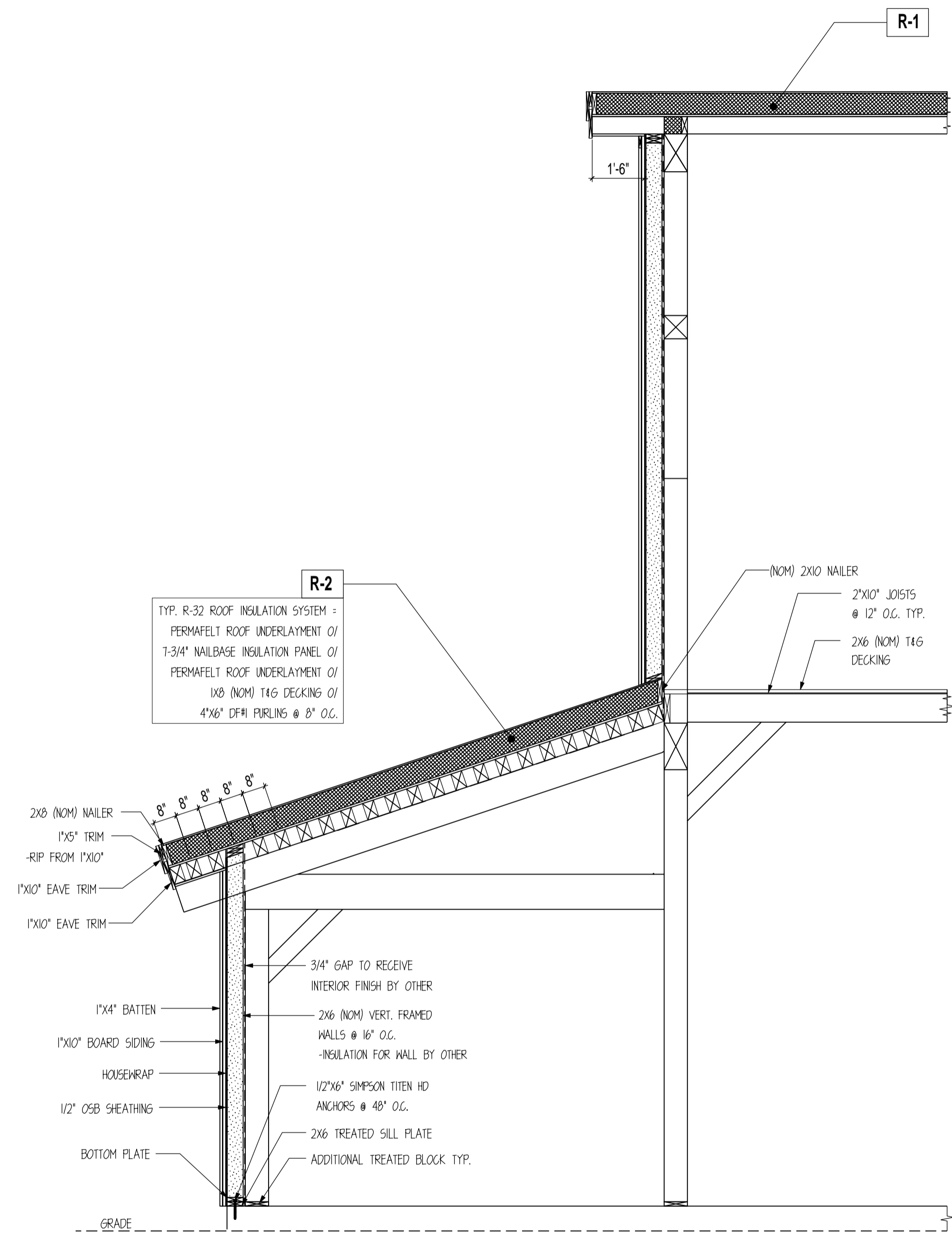

C EXTERIOR WALL SECTION
SCALE : 3/8" = 1'

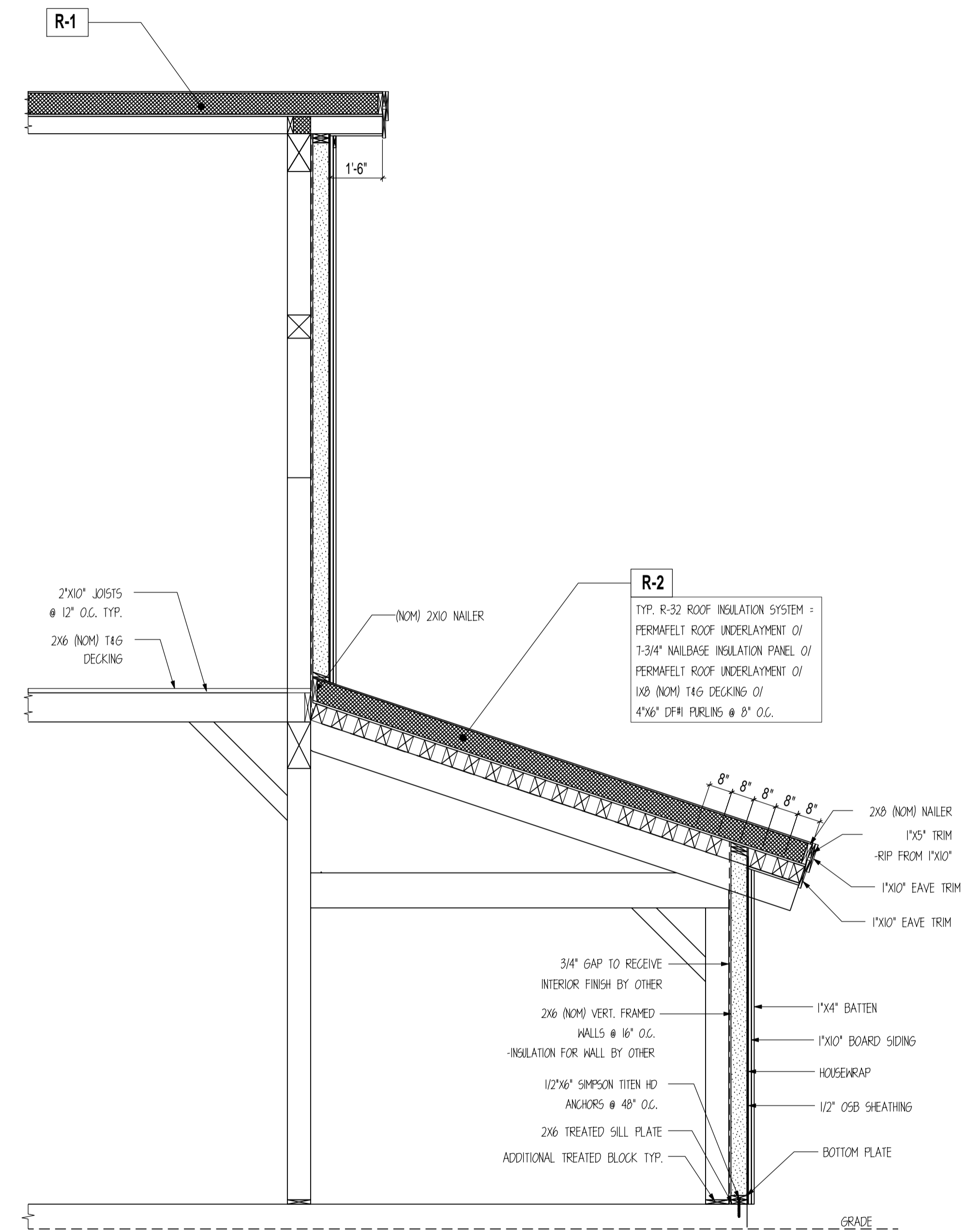

D EXTERIOR WALL SECTION
SCALE : 3/8" = 1'

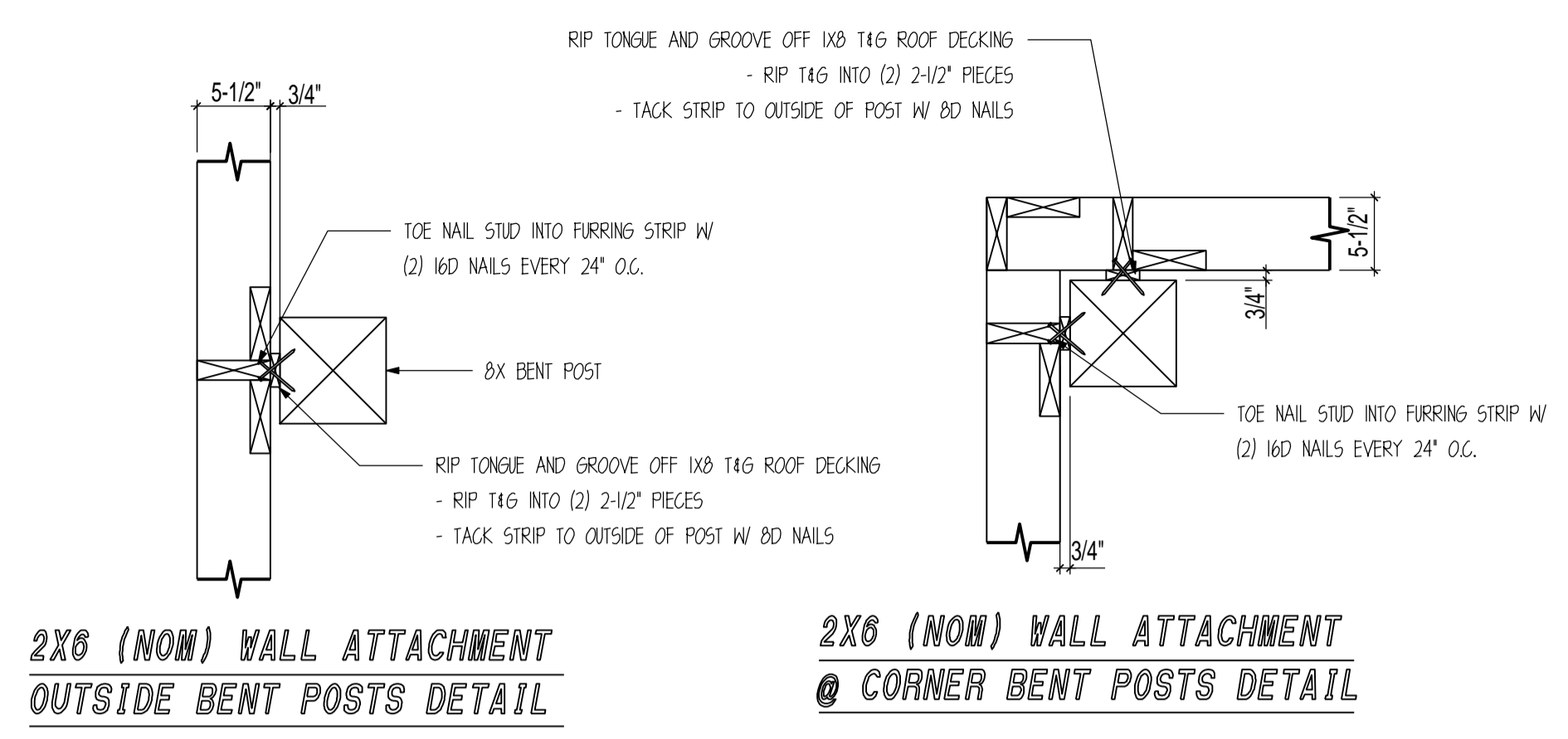

2X6 (NOW) WALL ATTACHMENT @ CORNER BENT POSTS DETAIL

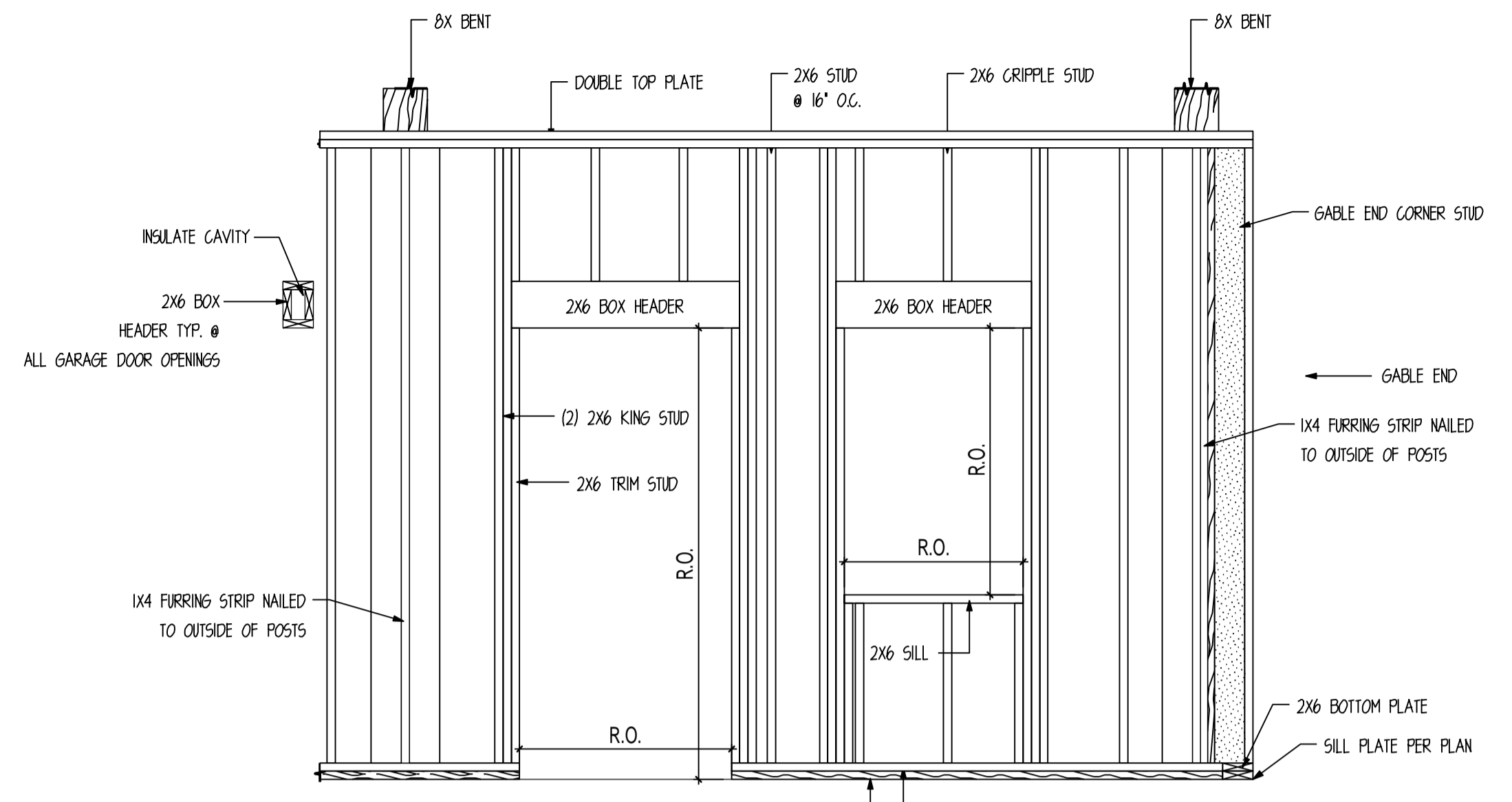

TYP. DOOR AND WINDOW FRAMING DETAIL
 *** CONTRACTOR TO VERIFY OPENING SIZE PRIOR TO FRAMING ***

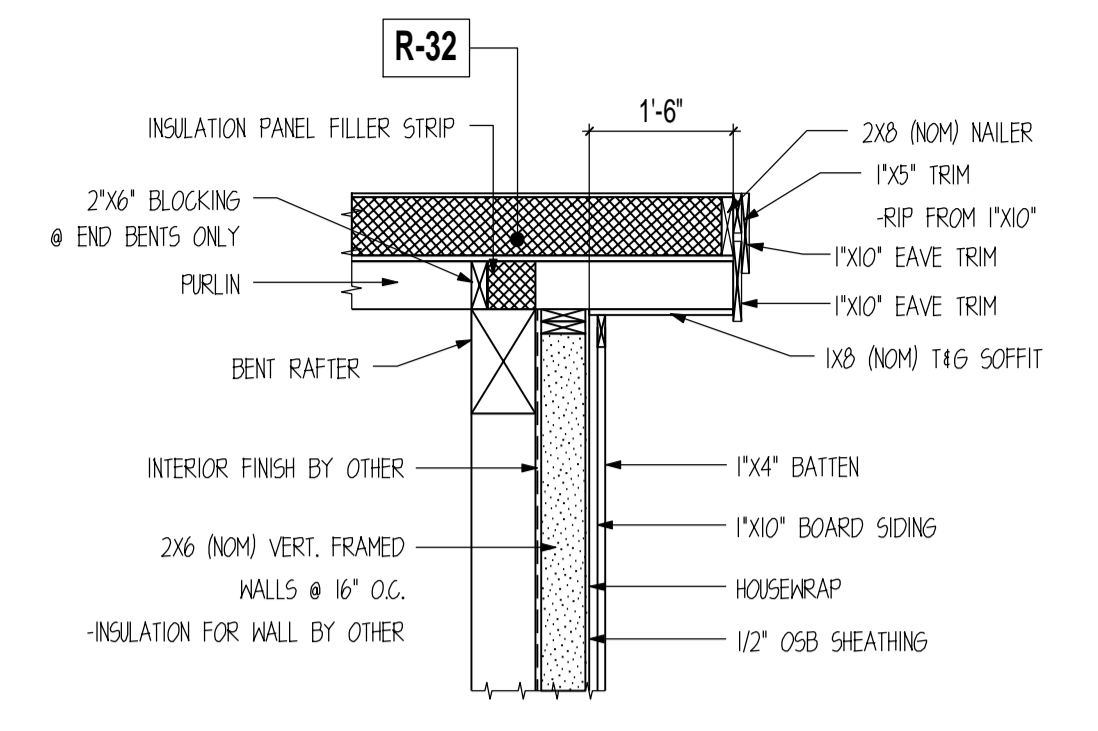

TYP. GABLE OVERHANG DETAIL
 SCALE: 1/2" = 1'-0"

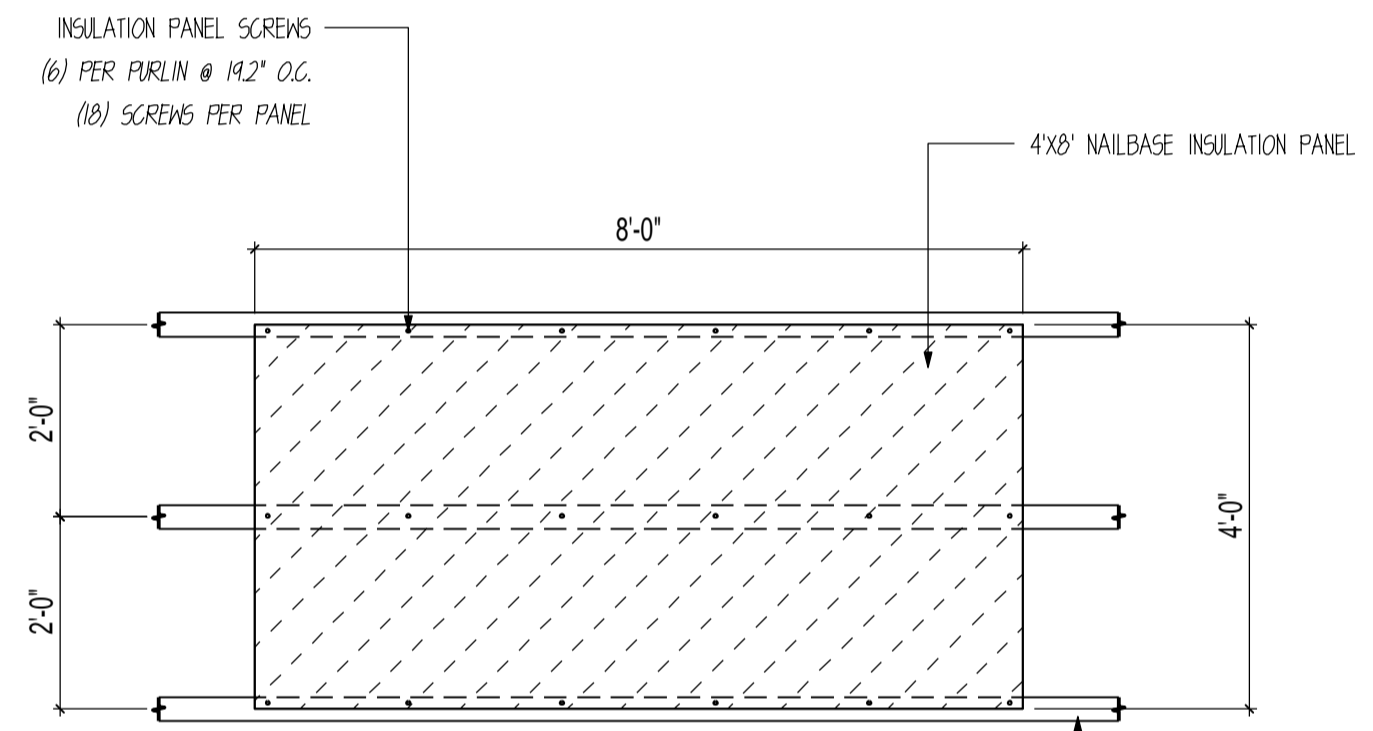

INSULATION PANEL DETAIL IN THE FIELD

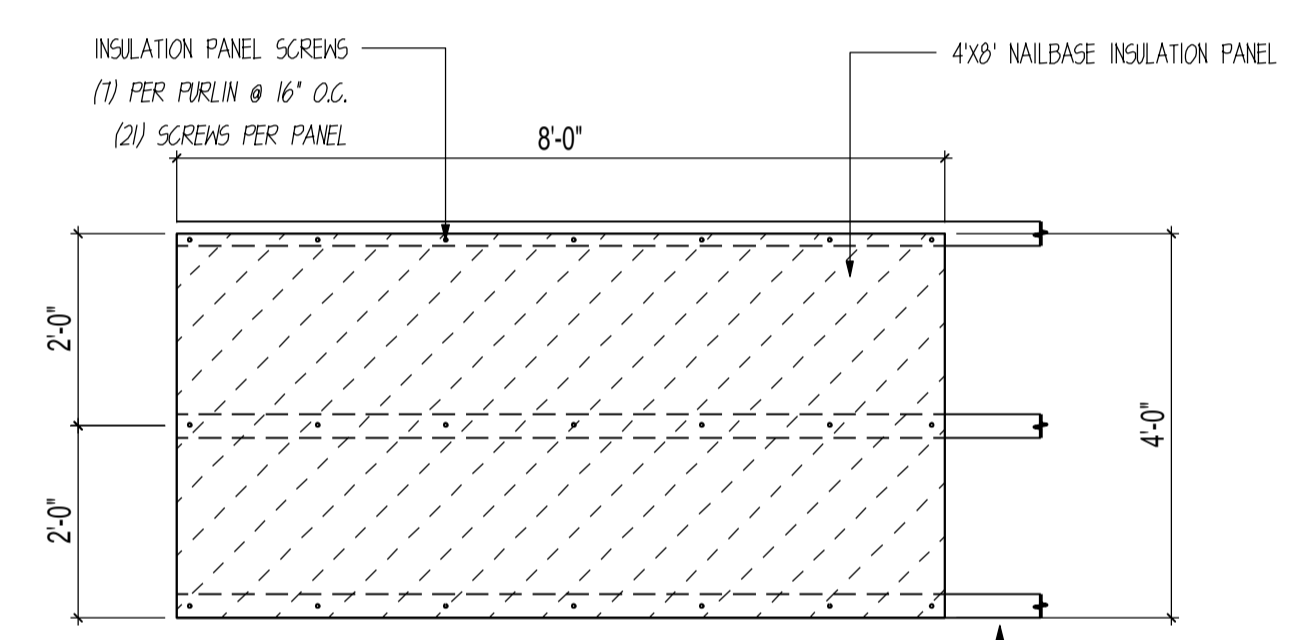

INSULATION PANEL DETAIL @ ROOF PERIMETER

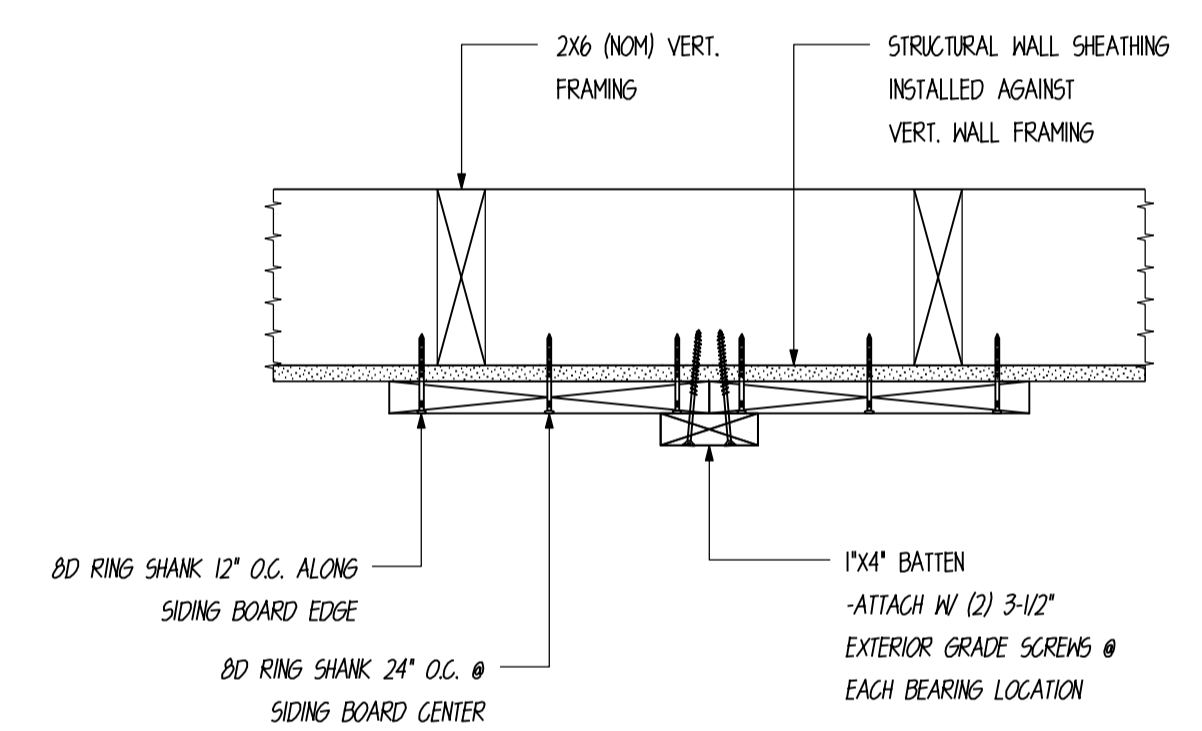

SIDING & BATTEN ATTACH. DETAIL

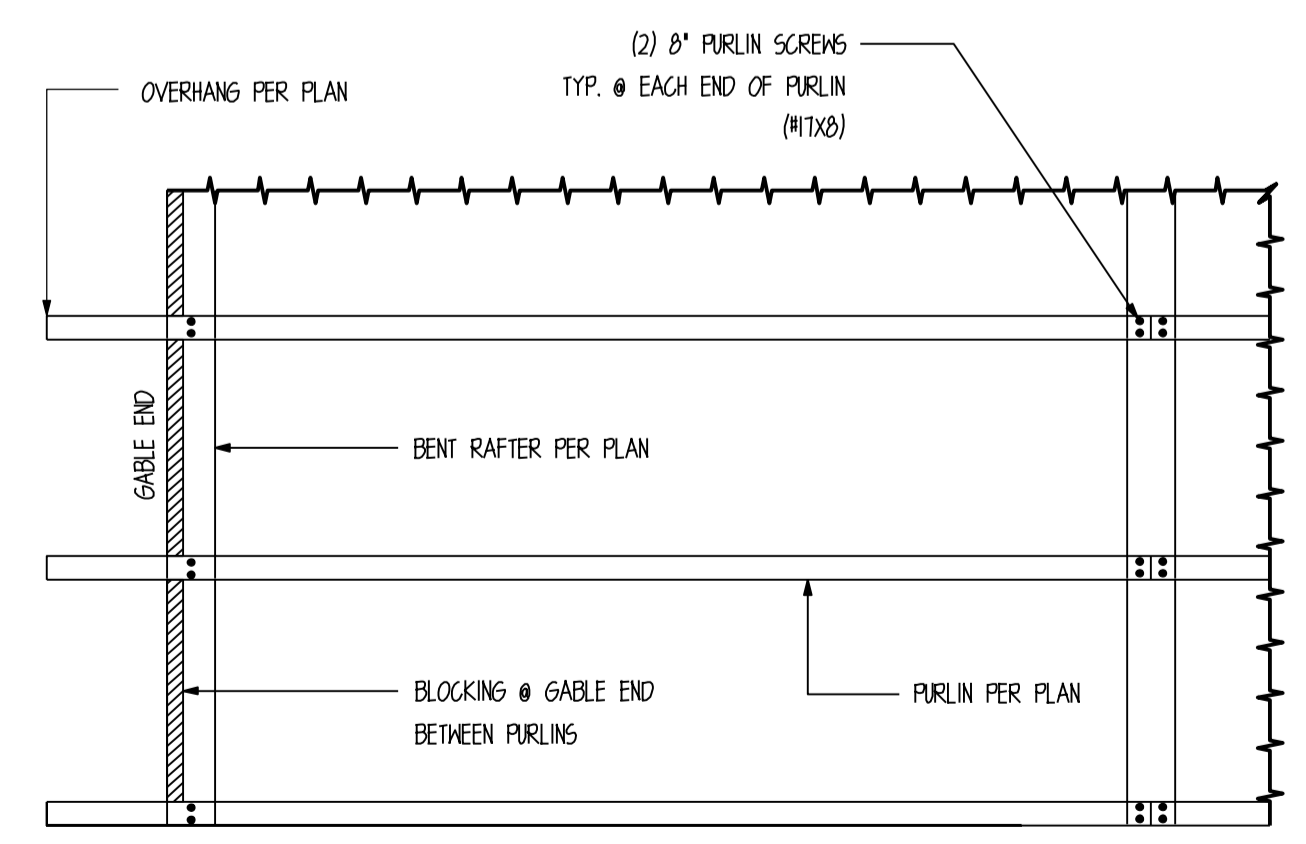

ROOF PURLIN ATTACHMENT DETAILS

NOTE: SEE PLAN FOR PURLIN SIZE AND SPACING

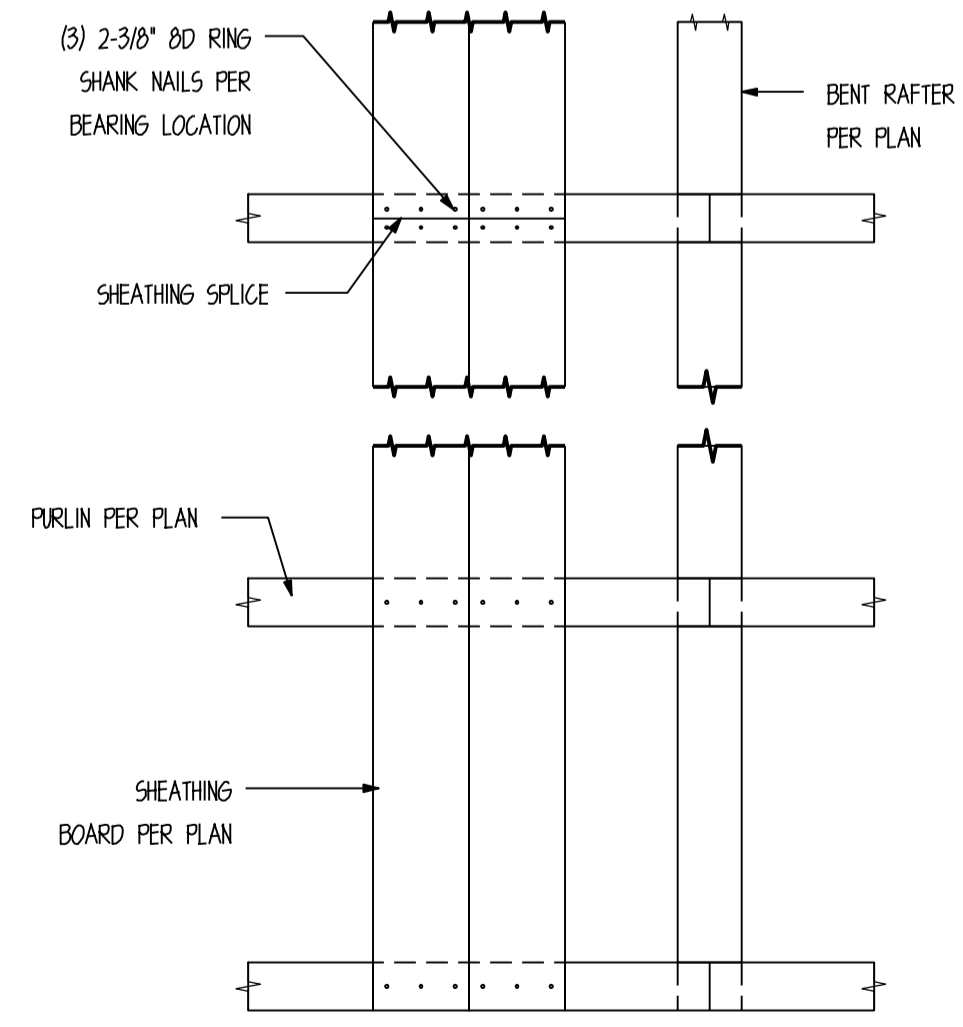

ROOF SHEATHING ATTACHMENT DETAILS

NOTE: FASTENERS NOT SUPPLIED IN SAND CREEK POST & BEAM BARN KIT

NOTE: WALLS TO BE VERTICAL FRAMED OUTSIDE OF POSTS

FASTENING SCHEDULE

CONNECTION	FASTENING	LOCATION
TOP PLATE TO STUD AND NAIL	2-16d	-----
STUD TO BOTTOM PLATE	4-8d, TOENAIL OR 2-16d, END NAIL	-----
DOUBLE STUDS, FACE NAIL	1-6d @ 24" (610 mm) O.C.	-----
DOUBLED TOP PLATES, TYP FACE NAIL	1-6d @ 16" (406 mm) O.C.	-----
CONTINUOUS HEADER, TWO PIECES	1-6d @ 16" (406 mm) O.C. ALONG EACH EDGE	-----
CONTINUOUS HEADER TO STUD, TOENAIL	4-8d	-----
STRUCTURAL WALL SHEATHING	SEE SHEAR WALL PLAN	SEE SHEAR WALL PLAN
1X12 & 1X12 SIDING	8D GALV. RING SHANK NAILS 12" O.C.	VERT. BOARD EDGE
1X2 & 1X4 BATTEN	(2)-EXTERIOR GRADE SCREWS @ 24" O.C.	OVER VERT. SIDING SEAMS
PURLIN TO BENTS	(2)-#1X8" SCREWS (PURLIN SCREWS)	@ EA. END
1X8" STRUCTURAL ROOF SHEATHING	(3)-8D GALV. RING SHANK	@ EA. BEARING LOCATION
LOFT JOIST TO TIE BEAM	(2)-16d	TOENAIL
2X6 T&G DECKING TO JOISTS	(2)-16d	BLIND & FACE NAIL

GENERAL NOTES:
 - FOR NAILING NOT SHOWN ON THESE DRAWINGS REFER TO IBC NAILING SCHEDULE
 - ALL NAILS TO BE PROVIDED BY CUSTOMER OR GENERAL CONTRACTOR
 - NOT ALL MATERIALS IN SCHEDULE MAY BE USED ON THIS PLAN
 - ALL NAILS COMMON UNLESS NOTED
 - PURLIN SCREWS PROVIDED BY TIMBERLYNE.

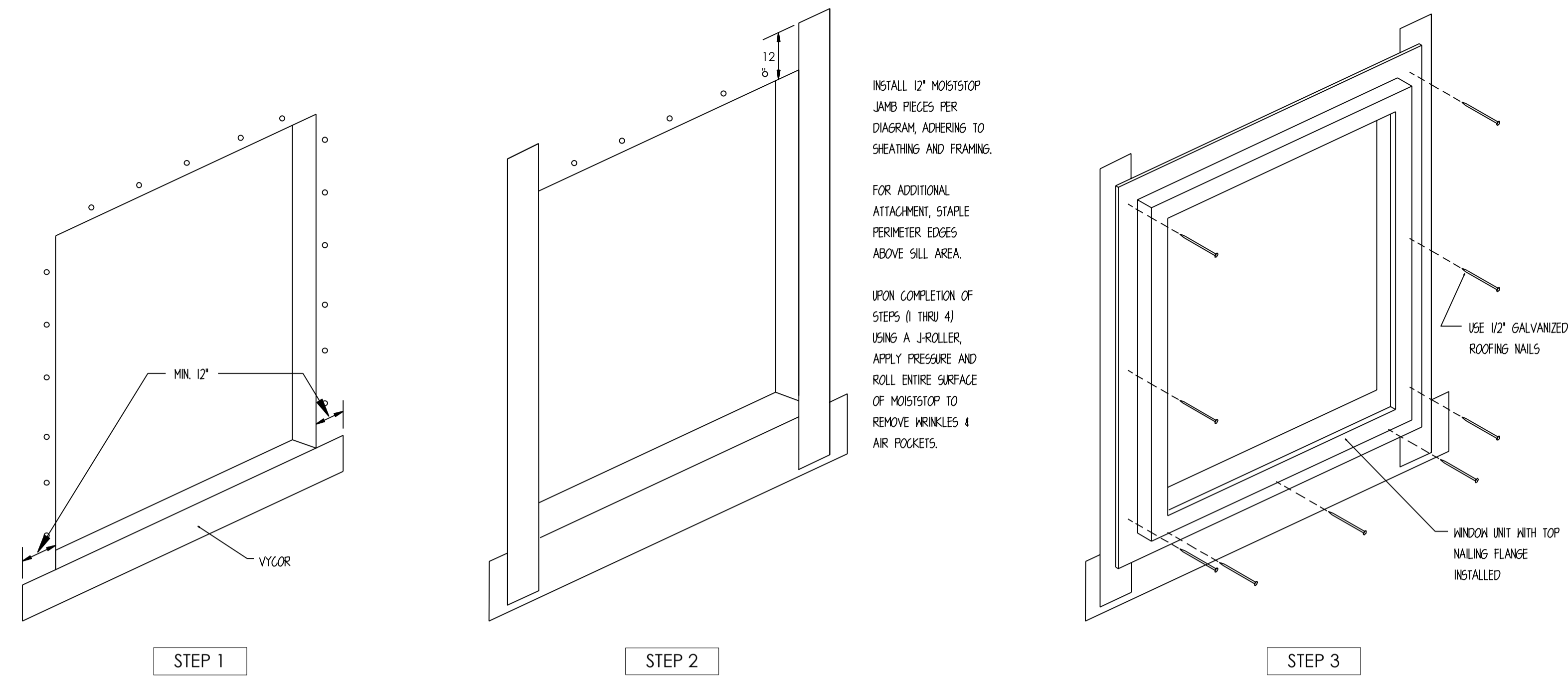

STEP 1
INSTALL 12" WIDE MOISTISTOP PER DIAGRAM, LEAVING RELEASE PAPER ON BACKSIDE, PLACE PAPER SIDE AGAINST SHEATHING AND ATTACH BY STAPLING OR NAILING ALONG TOP EDGE.

STEP 2

STEP 3

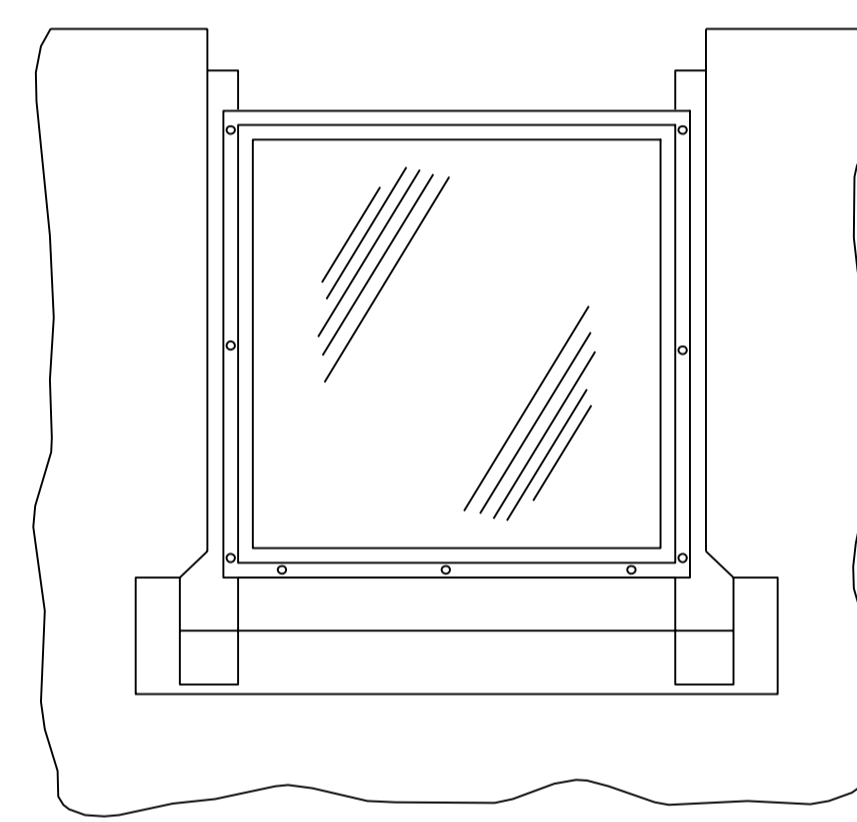

STEP 4
PLACE 60 MIL BUILDING PAPER AROUND WINDOWS AS SHOWN CONTINUOUS AROUND STRUCTURE - REMOVE BACKING FROM MOISTISTOP SILL PIECE AND ADHERE TO BUILDING WRAP

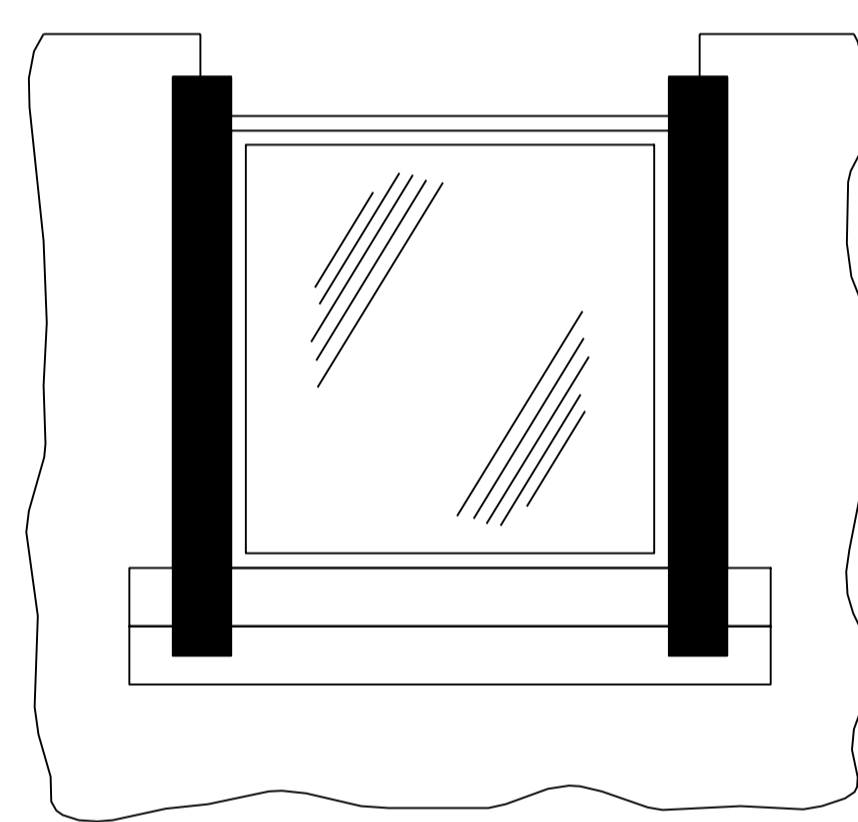

STEP 5
INSTALL 20 MIL VYCOR TAPE PER DIAGRAM ADHERING TO THE WINDOW SILL NAILING FLANGE.

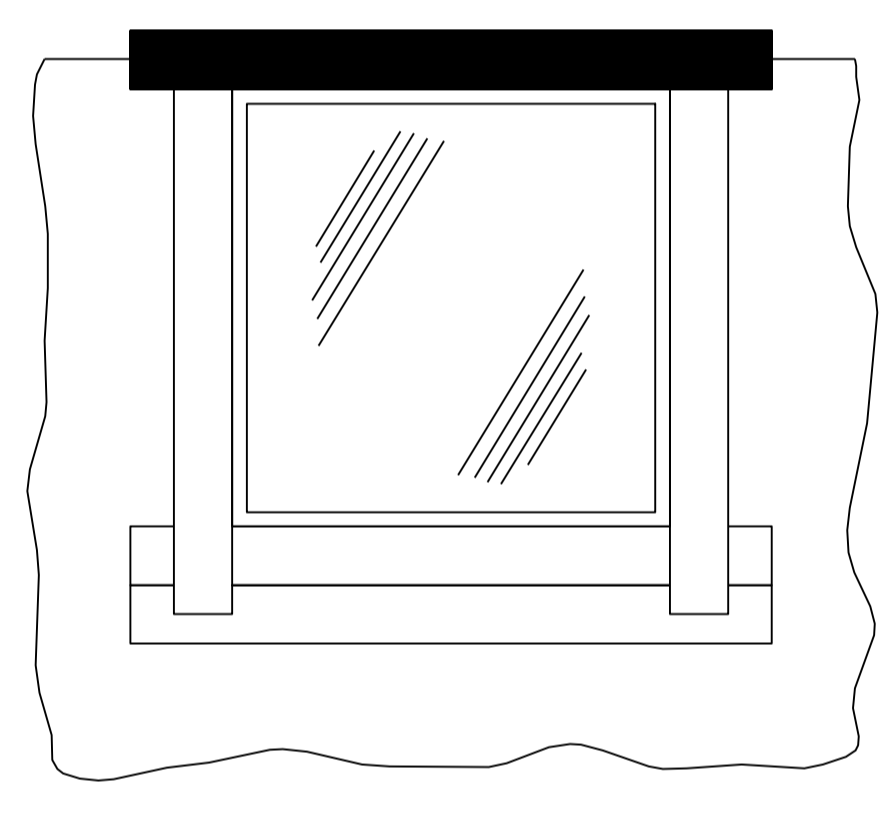

STEP 6
INSTALL 20 MIL VYCOR PER DIAGRAM, ADHERING TO THE WINDOW HEAD FLANGE AND SHEATHING.
UPON COMPLETION OF STEPS, USING A J-ROLLER, APPLY PRESSURE AND ROLL ENTIRE SURFACE OF VYCOR TO REMOVE WRINKLES AND AIR POCKETS.

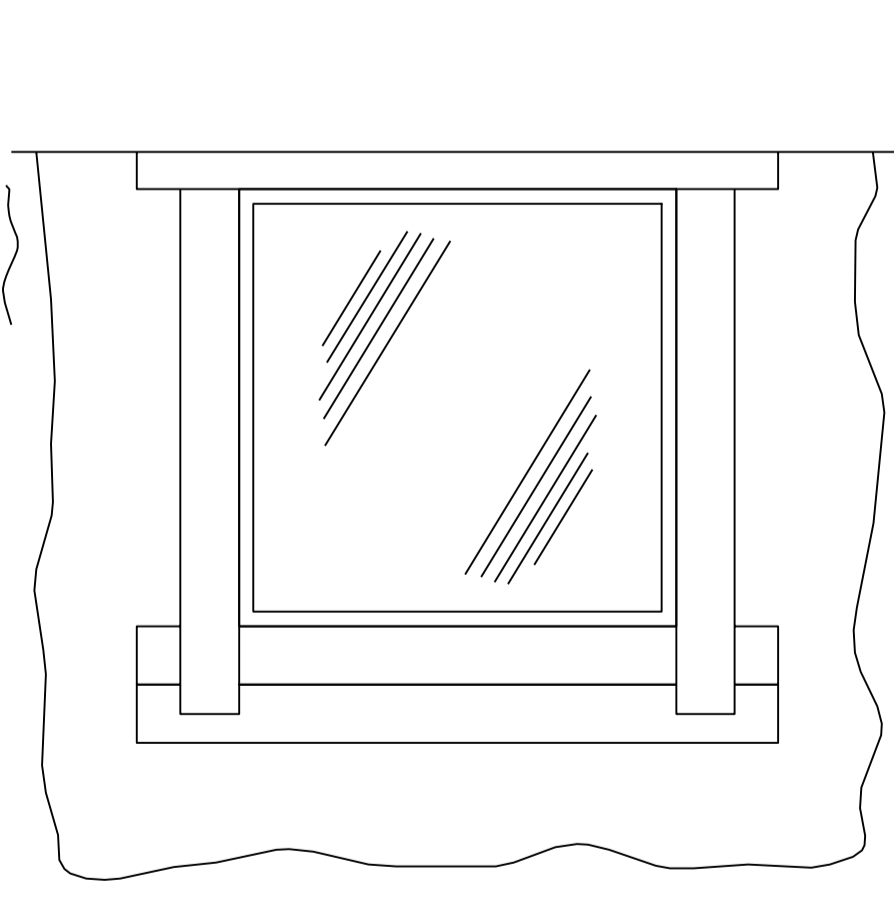

STEP 7
INSTALL 60 MIL BUILDING PAPER AS SHOWN CONTINUOUS AROUND STRUCTURE

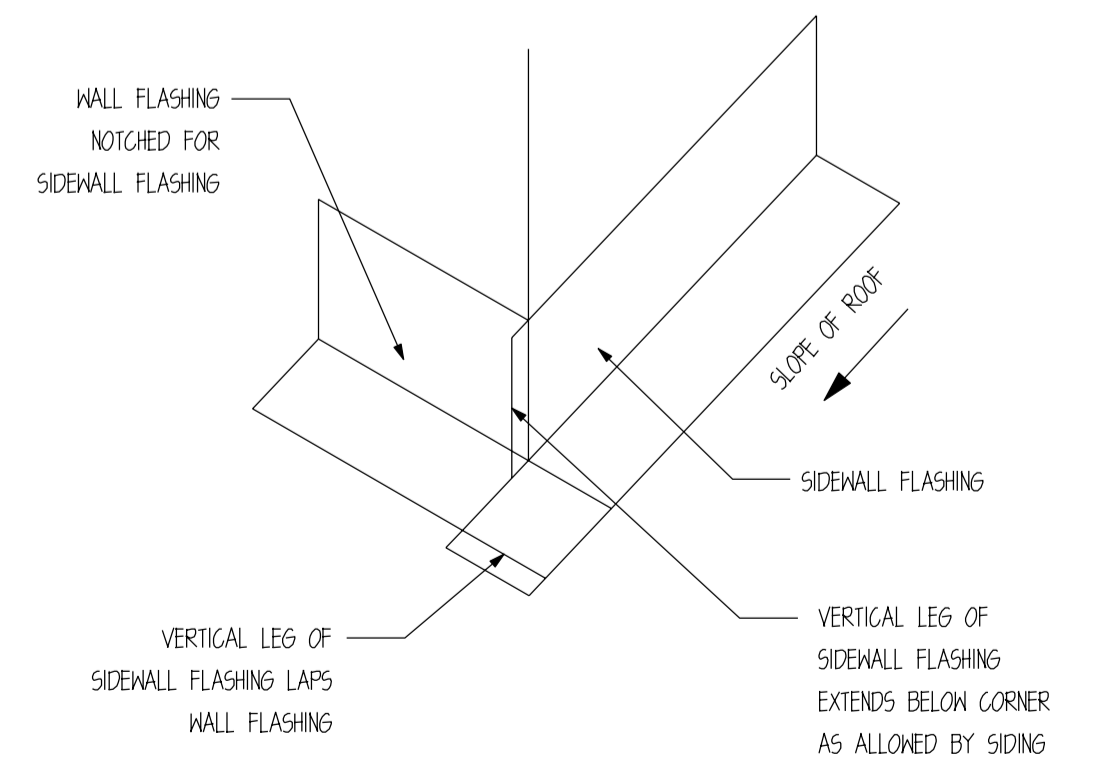

KICK-OUT FLASHING
SCALE: N.T.S.

CUSTOMER INFORMATION:

PENDER
SPORTS COMPLEX

PROJECT INFORMATION:

PENDER
COMPLEX
100 SLAUGHTER
PENDER, NE 68047
NUMBER: JGE1122-1 PSC
CATEGORY: COMMERCIAL
STYLE: GREAT PLAINS WESTERN
OTHER: --
OTHER: --
PM: --

DRAWING INFORMATION:

DRAWN BY: BJ
DATE: 09/13/2023
STATUS: FINAL PLAN SET
OTHER: --
OTHER: --

SHEET NOTES

SHEAR WALL SCHEDULE

MARK	WALL SHEATHING	NAIL SIZE	EDGE NAIL SPACING	FIELD NAIL SPACING
△6	1/2" OSB SHEATHING	8D NAILS	6" O.C.	12" O.C.

SHEARWALL NOTES:

1. VERT. 2X6 (NOM) STUDS @ 16" O.C. MAX.
2. ALL FIELD NAILING TO BE 12" O.C. AND ALL UNSUPPORTED PANEL EDGS ARE TO BE BLOCKED.
3. ALL SHEAR WALLS HAVE 2X6 TREATED SILL PLATE.
4. ALL SILL PLATE ANCHORED TO FOUNDATION W/ 1/2"X6" SIMPSON TITEN HD ANCHORS.
5. ANCHOR BOLTS SHALL BE PLACED @ ALL JAMBS, CORNERS, AND INTERSECTIONS.
6. FIELD VERIFY ALL DOOR AND WINDOW OPENINGS ON SITE PRIOR TO FRAMING OPENINGS.

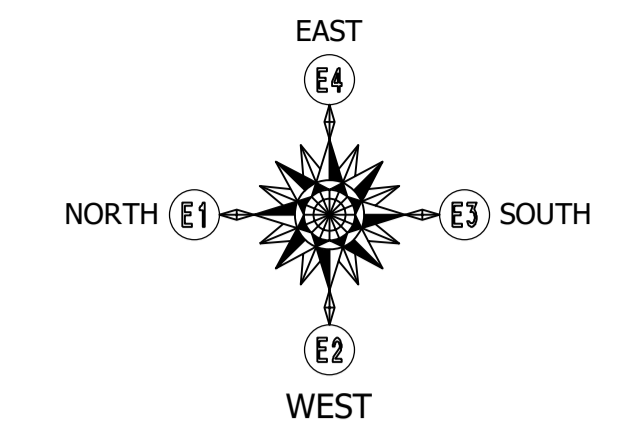

TIMBERLYNE

www.timberlyne.com

Nebraska: 116 West 1st Street
Wayne, NE 68787
888-489-1680

Texas: 613 Hwy 46 E.
Boerne, TX 78006
877-680-1680

© 2021 Timberlyne. All Rights Reserved.
THIS PLAN AND DESIGN CONTAINED HEREIN ARE THE PROPERTY OF TIMBERLYNE GROUP™ AND MAY NOT BE REPRODUCED WITHOUT PRIOR WRITTEN CONSENT FROM TIMBERLYNE GROUP™.

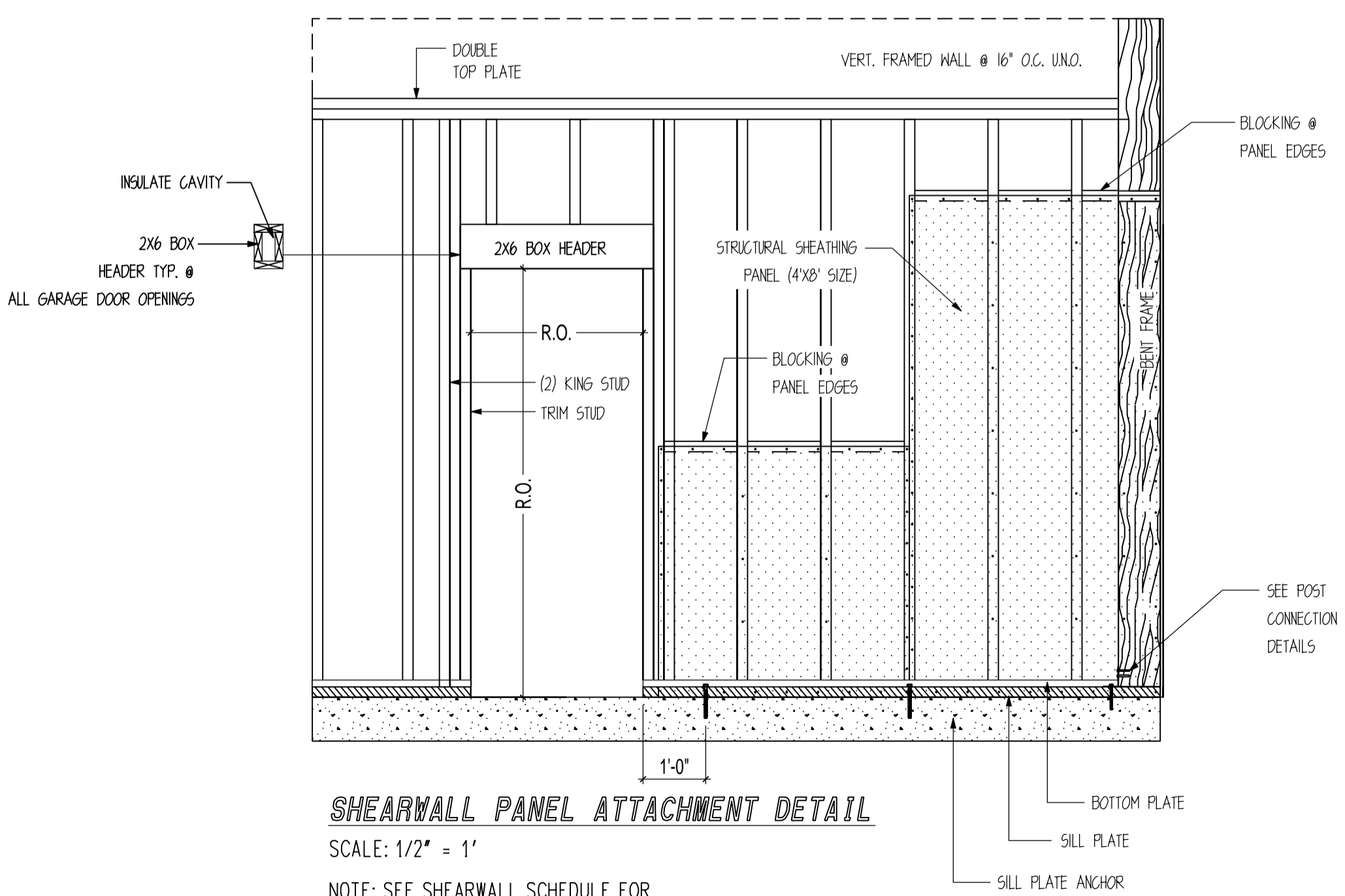
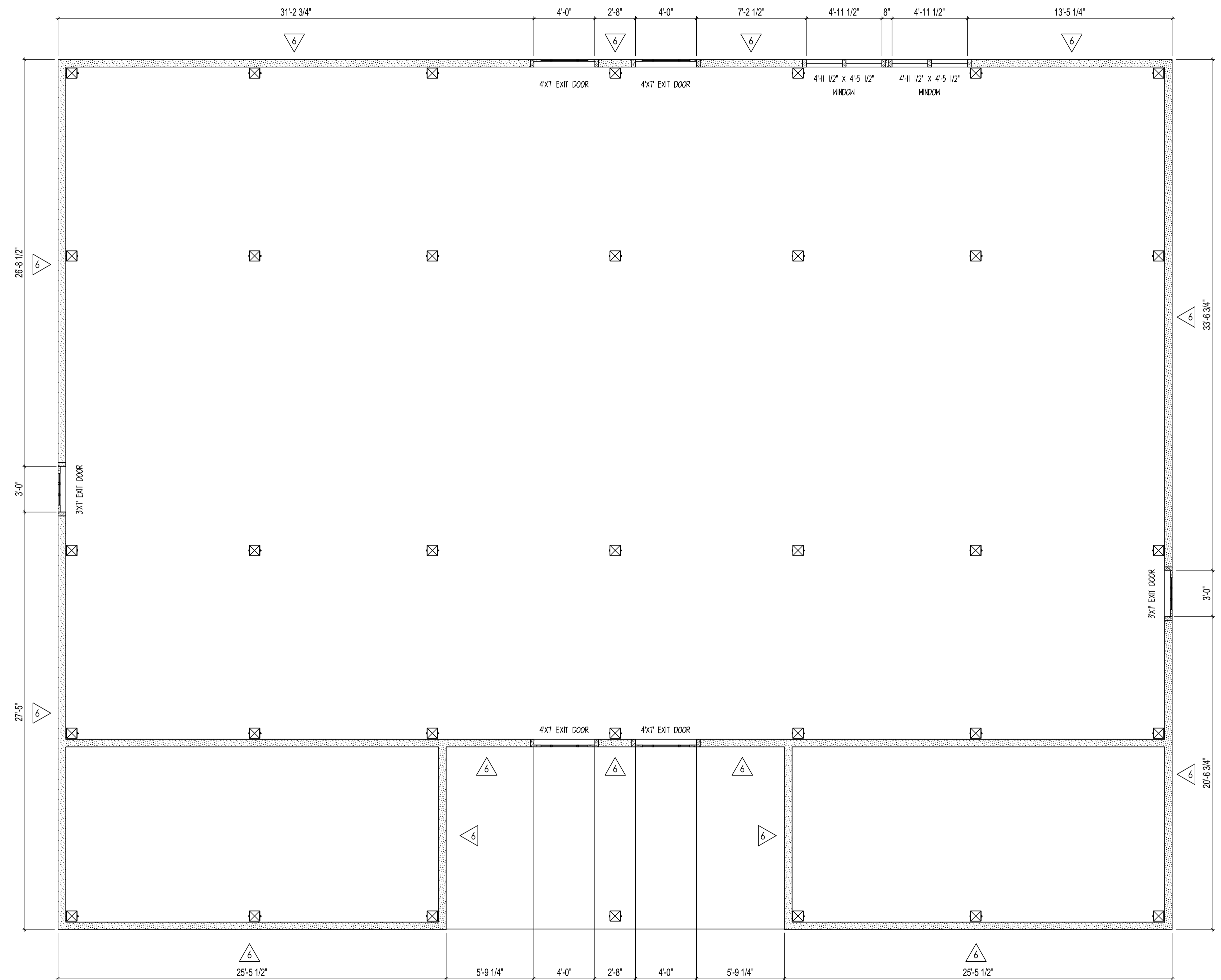

SHEARWALL PANEL ATTACHMENT DETAIL
SCALE: 1/2" = 1'
NOTE: SEE SHEARWALL SCHEDULE FOR ALL PANEL ATTACHMENTS AT PANEL EDGES AND IN THE FIELD OF THE PANEL.

MAIN FLOOR SHEAR WALL LAYOUT
SCALE: 1/4" = 1'
NOTE: CONTRACTOR TO FIELD VERIFY OPENING SIZES PRIOR TO FRAMING.

CUSTOMER INFORMATION:
PENDER
SPORTS COMPLEX

PROJECT INFORMATION:
PENDER
COMPLEX
100 SLAUGHTER
PENDER, NE 68047
NUMBER: JGE1122-1 PSC
CATEGORY: COMMERCIAL
STYLE: GREAT PLAINS WESTERN
OTHER: --
OTHER: --
PM: --

DRAWING INFORMATION:
DRAWN BY: BJ
DATE: 09/13/2023
STATUS: FINAL PLAN SET
OTHER: --
OTHER: --

SHEET NOTES

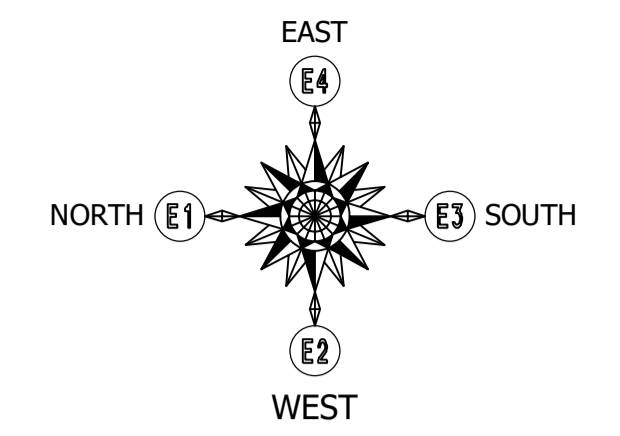

SHEAR WALL SCHEDULE

MARK	WALL SHEATHING	NAIL SIZE	EDGE NAIL SPACING	FIELD NAIL SPACING
△6	1/2" OSB SHEATHING	8D NAILS	6" O.C.	12" O.C.

SHEARWALL NOTES:

1. VERT. 2X6 (NOM) STUDS @ 16" O.C. MAX.
2. ALL FIELD NAILING TO BE 12" O.C. AND ALL UNSUPPORTED PANEL EDGS ARE TO BE BLOCKED.
3. ALL SHEAR WALLS HAVE 2x6 TREATED SILL PLATE.
4. ALL SILL PLATE ANCHORED TO FOUNDATION W/ 1/2"x6" SIMPSON TITEN HD ANCHORS.
5. ANCHOR BOLTS SHALL BE PLACED @ ALL JAMBS, CORNERS, AND INTERSECTIONS.
6. FIELD VERIFY ALL DOOR AND WINDOW OPENINGS ON SITE PRIOR TO FRAMING OPENINGS.

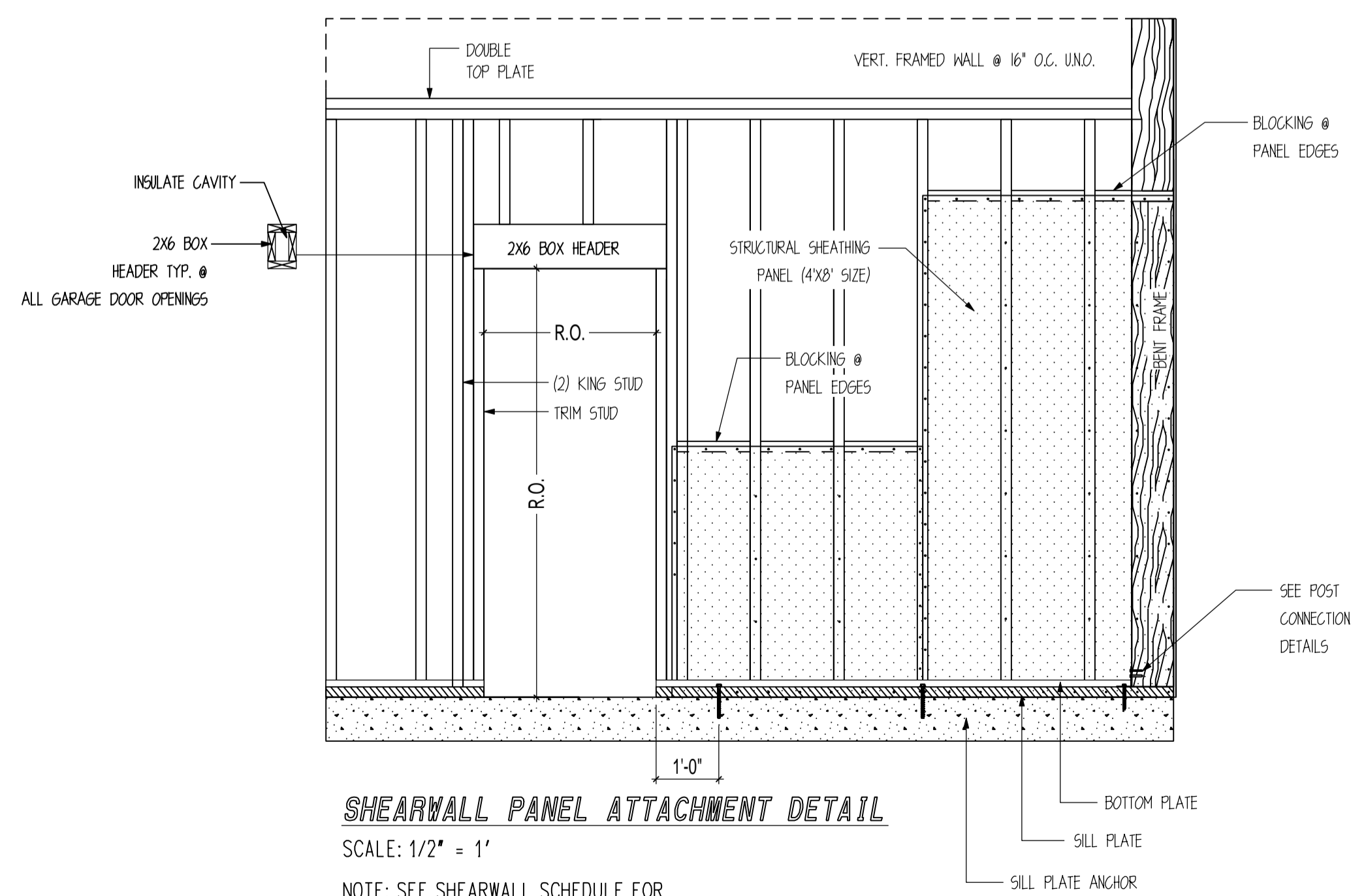
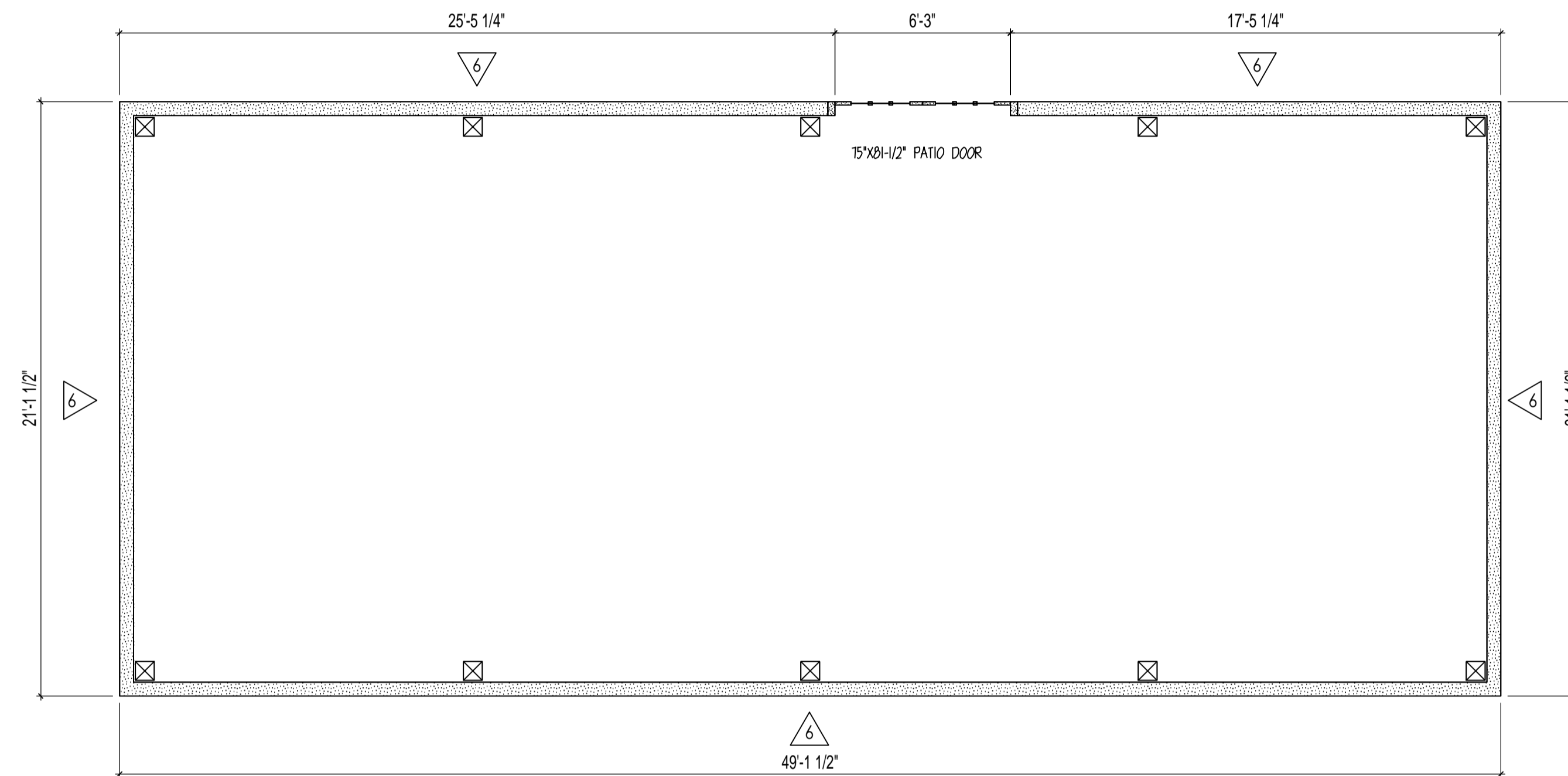

SHEARWALL PANEL ATTACHMENT DETAIL
 SCALE: 1/2" = 1'
 NOTE: SEE SHEARWALL SCHEDULE FOR ALL PANEL ATTACHMENTS AT PANEL EDGES AND IN THE FIELD OF THE PANEL.

LOFT FLOOR SHEAR WALL LAYOUT
 SCALE: 1/4" = 1'
 NOTE: CONTRACTOR TO FIELD VERIFY OPENING SIZES PRIOR TO FRAMING.

CUSTOMER INFORMATION:

PENDER
 SPORTS COMPLEX

PROJECT INFORMATION:

PENDER COMPLEX
 100 SLAUGHTER
 PENDER, NE 68047
 NUMBER: JGE1122-1 PSC
 CATEGORY: COMMERCIAL
 STYLE: GREAT PLAINS WESTERN
 OTHER: --
 OTHER: --
 PM: --

DRAWING INFORMATION:

DRAWN BY: BJ
 DATE: 09/13/2023
 STATUS: FINAL PLAN SET
 OTHER: --
 OTHER: --

SHEET NOTES

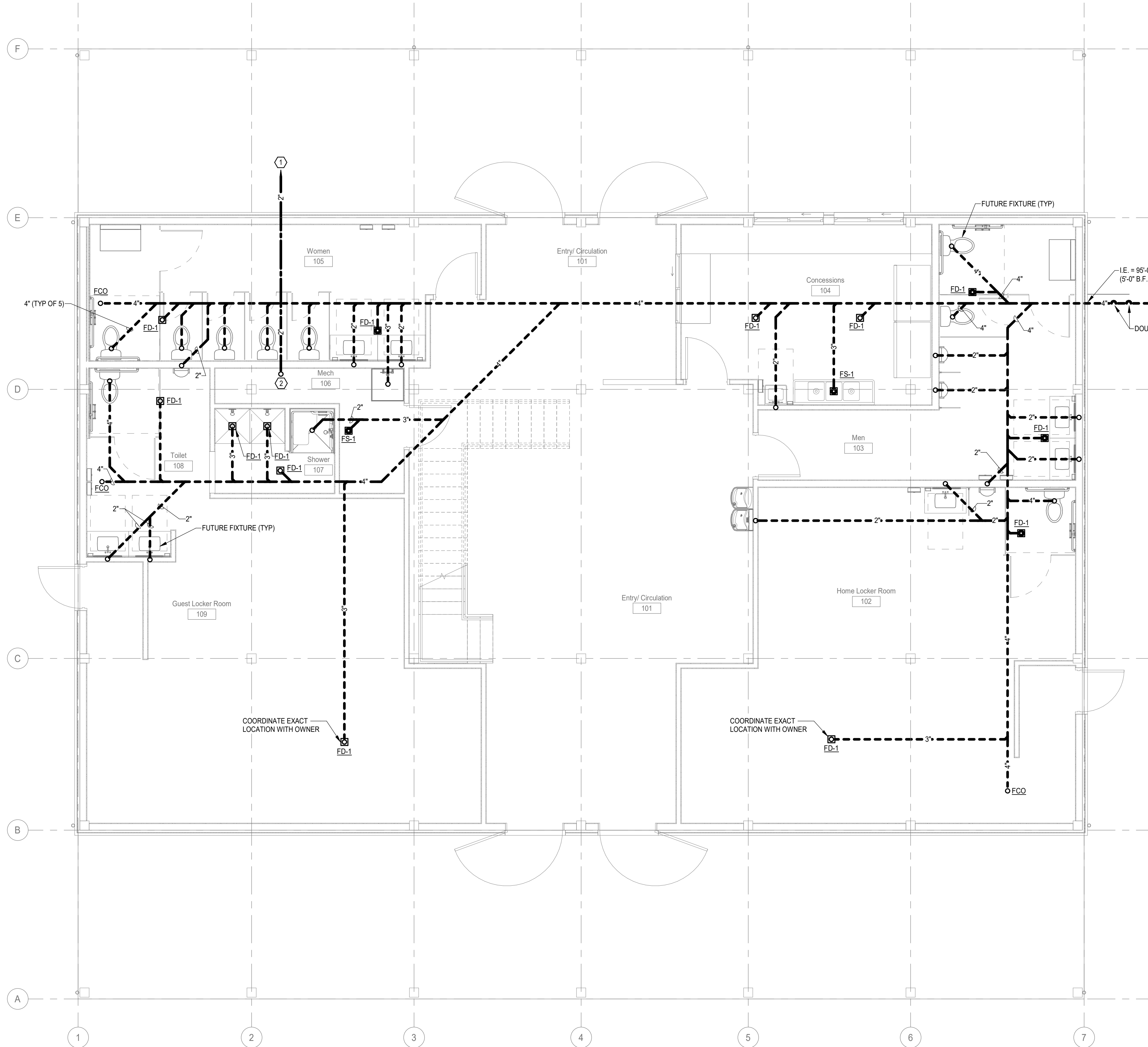

1 PLUMBING PLAN
1/4" = 1'-0"

MECHANICAL SHEET LIST	
SHEET NO.	SHEET NAME
M101	PLUMBING PLAN AND DETAILS
M201	MECHANICAL SCHEDULES, SPECIFICATIONS AND WASTE RISER DIAGRAM

MECHANICAL SYMBOL LEGEND	
GENERAL	
	EXISTING
	DEMOLITION
	NEW
	NEW TO EXISTING
	SHEET KEYNOTE
	REVISION DELTA
	PIPE UP OR DUCT UP
SANITARY & DOMESTIC	
	SANITARY DRAIN BELOW GRADE (PLAN)
	SANITARY DRAIN ABOVE GRADE (PLAN)
	COLD WATER (CW)

GENERAL SHEET NOTES

- COORDINATE UNDERGROUND PIPING WITH STRUCTURAL FOOTINGS, SITE UTILITIES SERVICES, AND BUILDING SERVICES. FIELD VERIFY LOCATION OF ALL UTILITIES AND EXACT DIMENSIONS DURING BIDDING PORTION OF PROJECT. NOTIFY ANY DISCREPANCY OR INTERFERENCE TO ENGINEER.
- BUILDING 4" OR LARGER SANITARY MAIN AND SEWER PIPING SHALL SLOPE AT A MINIMUM 1/8" PER FOOT SLOPE OR GREATER. 3" AND SMALLER PIPING SHALL SLOPE AT A MINIMUM OF 1/4" PER FOOT SLOPE OR GREATER.
- ALL UNDERSLAB WATER PIPING SHALL BE BURIED BELOW FROST DEPTH.
- REFER TO SANITARY AND VENT RISER DIAGRAMS AND PLUMBING FIXTURE SCHEDULES FOR PIPING AND SIZES NOT SHOWN.
- INSTALL WATER CLOSET FLANGE AT ALL FUTURE WATER CLOSET LOCATIONS.

SHEET KEYNOTES

- EXTEND PIPING A MIN. OF 5'-0" FROM BUILDING AS SHOWN AND MAKE FINAL CONNECTION TO UTILITY MAIN. SEE CIVIL PLANS FOR SITE PIPING.
- STUB UP 2" CW 12" A.F.F. WITH ISOLATION VALVE AND CAP.

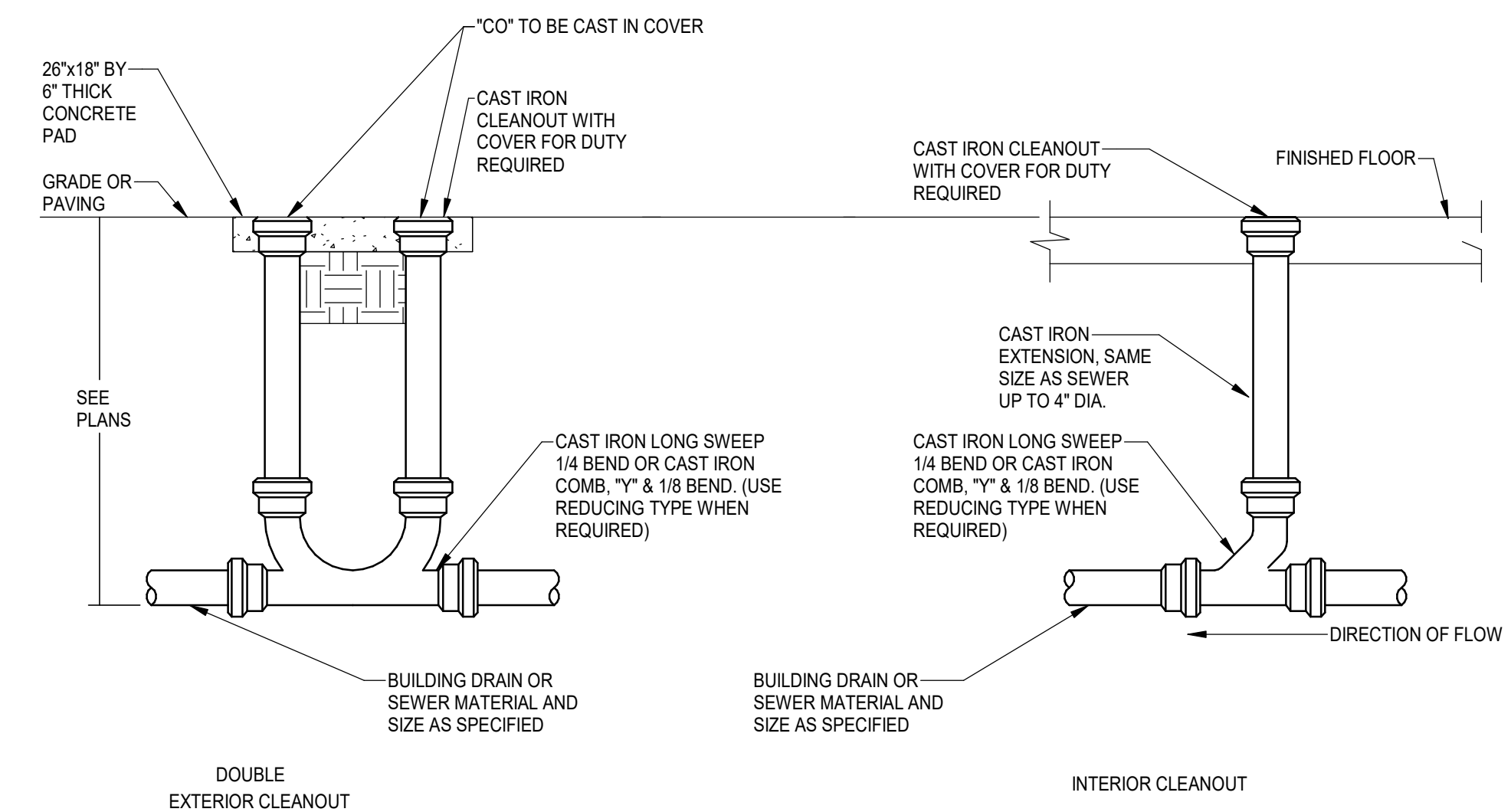

2 TYPICAL CLEANOUTS
NOT TO SCALE

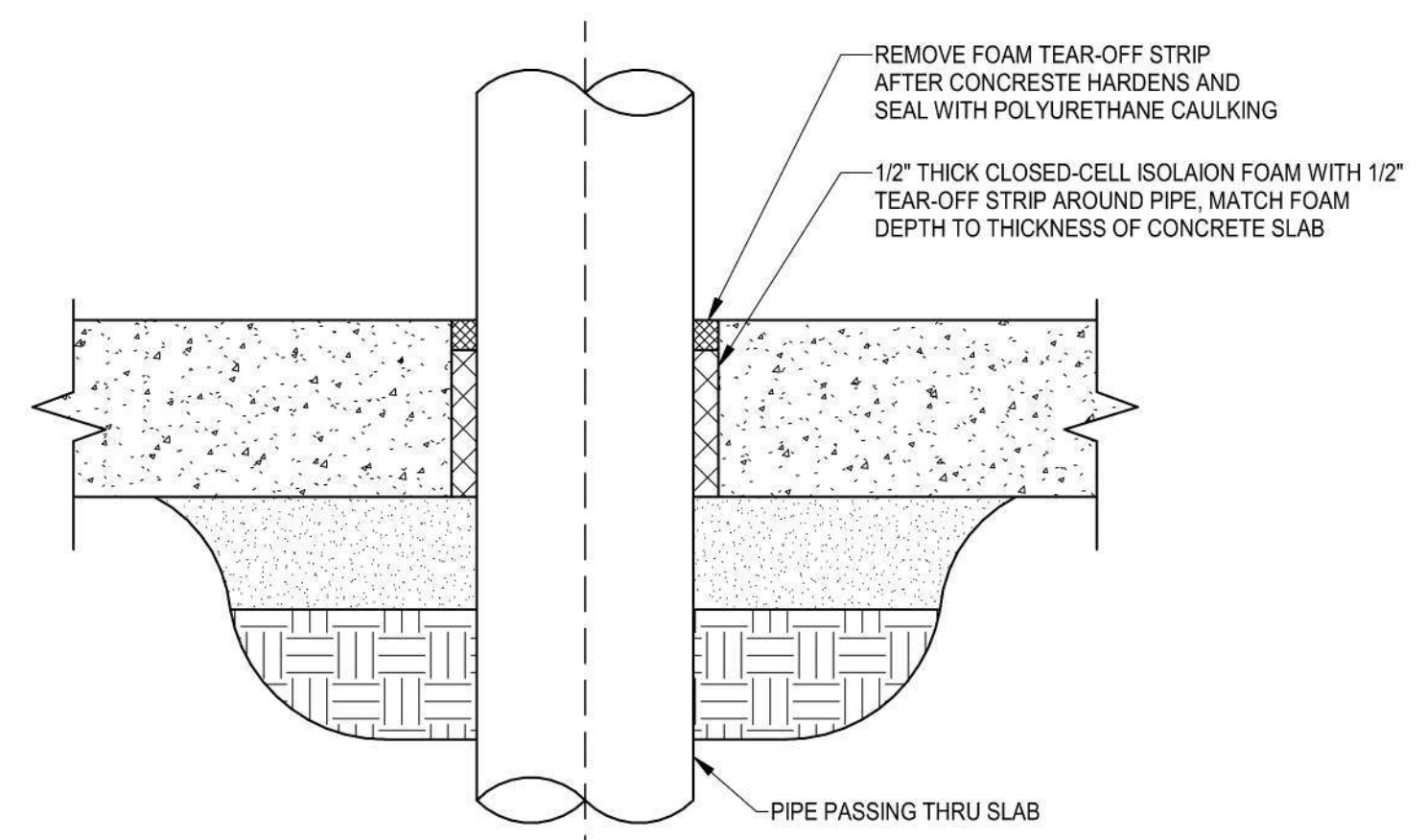

3 PIPE PENETRATION THRU SLAB ON GRADE
NOT TO SCALE



olsson

Engineering - Nebraska COA #CA-0638
601 P Street Suite 200
Lincoln, NE 68508

TEL 402.474.6311
FAX 402.474.5160

www.olsson.com

COPYRIGHT 2023
PETERS AND ASSOCIATES ARCHITECTS P.C. THESE DOCUMENTS ARE ISSUED BY PETERS AND ASSOCIATES ARCHITECTS P.C. AND ARE PROTECTED BY COPYRIGHT LAW. THEY MAY NOT BE REPRODUCED OR DUPLICATED IN WHOLE OR IN PART WITHOUT EXPRESS WRITTEN PERMISSION OF PETERS AND ASSOCIATES ARCHITECTS P.C., BELLEVUE, NE.

For Review Only
NOT FOR CONSTRUCTION

REVISIONS
AUGUST 1, 2023
PROJECT #: 23-09

PLUMBING PLAN AND DETAILS

PENDER PUBLIC SCHOOLS - SPORTS COMPLEX BUILDING
PENDER, NEBRASKA

PETERS & ASSOCIATES ARCHITECTS, P.C.
SUITE E
1103 CALVIN ROAD SOUTH,
BELLEVUE, NEBRASKA
402-895-2292
PHONE



M101

8/1/2023 1:20:07 PM B:\300725301\PS - Sports Complex Building\ME_Pender_Sports Complex_Central_052-0305.rvt

PLUMBING FIXTURE SCHEDULE

TAG	TYPE	MANUFACTURER	MODEL	DESCRIPTION	ACCESSORIES	CONNECTIONS			
						WASTE	VENT	CW	HW
FD-1	HEAVY DUTY FLOOR DRAIN	ZURN	Z-415-HD	CAST IRON TWO PIECE BODY WITH DOUBLE DRAINAGE FLANGE, WEEP HOLES, REVERSIBLE CLAMPING COLLAR, HEAVY DUTY 6" SLOTTED GRATE	PROVIDE A GASKETED TRAP SEALER BY SURE SEAL OR EQUAL, IN NECK OF FLOOR DRAIN.	3"	2"	-	-
FS-1	SQUARE FLOOR SINK	ZURN	Z-1901	12x12x8 DEEP CAST IRON BODY AND SQUARE SLOTTED MEDIUM DUTY GRATE, WITH WHITE ACID RESISTING PORCELAIN ENAMEL INTERIOR AND TOP, COMPLETE WITH WHITE ABS ANTI-SPLASH INTERIOR BOTTOM DOME STRAINER.	PROVIDE WITH 3/4 GRATE AND SECURITY SCREWS. PROVIDE A GASKETED TRAP SEALER BY SURE SEAL OR EQUAL, IN NECK OF FLOOR SINK.	3"	2"	-	-
FCO	FLOOR CLEANOUT	ZURN	Z1400	DURA COATED CAST IRON BODY, GAS AND WATERTIGHT ABS TAPERED THREAD PLUG AND ROUND POLISHED NICKEL BRONZE SCORIATED SECURED TOP, ADJUSTABLE TO FINISHED FLOOR.	CLEANOUT SHALL BE THE SAME SIZE AS PIPING UP TO 4". 4" AND LARGER PIPING SHALL BE A 4" CLEANOUT.	-	-	-	-
ECO	EXTERIOR CLEANOUT	ZURN	Z1400-HD	DURA COATED CAST IRON BODY, GAS AND WATERTIGHT ABS TAPERED THREAD PLUG AND ROUND POLISHED NICKEL BRONZE SCORIATED SECURED TOP, ADJUSTABLE TO FINISHED FLOOR, EXTRA-HEAVY-DUTY VENEER TOP.	CLEANOUT SHALL BE THE SAME SIZE AS PIPING UP TO 4". 4" AND LARGER PIPING SHALL BE A 4" CLEANOUT.	-	-	-	-

GENERAL NOTES:
 1. VERIFY ALL CONNECTIONS & MOUNTING HEIGHTS WITH CODES, MANUFACTURERS, AND PLANS.
 2. SIZES LISTED INDICATE MIN. SIZE ONLY. SEE PLUMBING RISERS AND FLOOR PLANS FOR LARGER SIZES.
 3. ALTERNATE MANUFACTURERS: JAY R SMITH

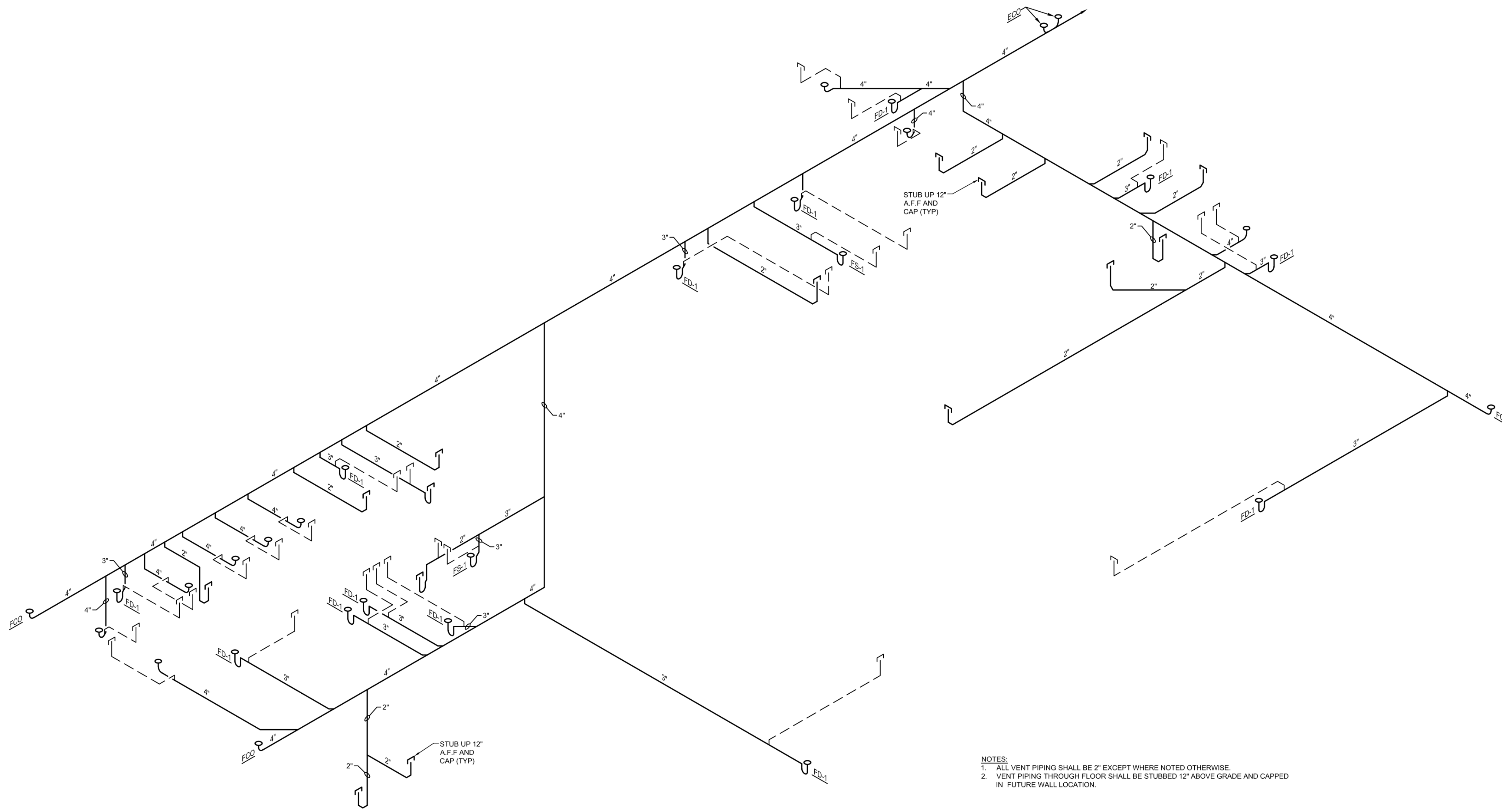

NOTES:
 1. ALL VENT PIPING SHALL BE 2" EXCEPT WHERE NOTED OTHERWISE.
 2. VENT PIPING THROUGH FLOOR SHALL BE STUBBED 12" ABOVE GRADE AND CAPPED IN FUTURE WALL LOCATION.

1 WASTE RISER DIAGRAM
 NOT TO SCALE

DIVISION 22 - MECHANICAL SPECIFICATIONS

SECTION 220000 - GENERAL PROVISIONS

THE DRAWINGS, GENERAL NOTES, GENERAL CONDITIONS, AND DIVISION 1 GENERAL REQUIREMENTS SHALL BE CONSIDERED AS PART OF THIS SPECIFICATION.

ALL MATERIALS AND EQUIPMENT SHALL BE NEW, INSTALLED IN FULL COMPLIANCE WITH MANUFACTURER'S RECOMMENDATIONS, INSTALLED IN ACCORDANCE WITH ACCEPTED GOOD PRACTICE OF THE INDUSTRY AND ALL APPLICABLE ITEMS SHALL CARRY A U.L. LABEL.

THE WORD "PROVIDE" AS USED HEREIN MEANS TO FURNISH AND INSTALL COMPLETE, INCLUDING ALL ITEMS NECESSARY FOR A FULLY-FUNCTIONAL SYSTEM.

FAMILIARIZE ONESELF WITH ALL REQUIREMENTS AS TO PERMITS, LICENSES, FEES, CODES AND ORDINANCES AND ARRANGE TO COMPLY WITH THEM. ALL PERMITS, LICENSES, FEES AND INSPECTIONS REQUIRED FOR THE WORK UNDER THIS CONTRACT SHALL BE OBTAINED AND PAID FOR UNLESS OTHERWISE SPECIFIED.

ALL WORK SHALL BE IN COMPLIANCE WITH APPLICABLE NFPA, NEC, ANSI, UL, SMACNA AND ASHRAE CODES AND STANDARDS UNLESS SUPERCEDED BY STATE AND LOCAL REGULATION. CONFORM TO DOCUMENTS WHEN CODES ARE EXCEEDED.

EXAMINE SITE BEFORE BIDDING. ADVISE ENGINEER PRIOR TO BID IF SITE CONDITIONS DICTATE MODIFICATION TO THE BASE DESIGN.

COORDINATE ALL WORK WITH OTHER TRADES AND VERIFY ALL DIMENSIONS AND CONDITIONS IN THE FIELD. CUT AND PATCH ONLY AS REQUIRED. COORDINATE ALL CHANGES TO BUILDING STRUCTURE WITH ARCHITECT/ENGINEER AND THEIR REQUIREMENTS PRIOR TO EXECUTION.

EXCAVATING AND BACK FILLING PIPE TRENCHES SHALL BE ACCURATELY GRADED TO PROVIDE UNIFORM SUPPORT ON UNDISTURBED SOIL FOR PIPING. SHEETING, SHORING AND BRACING SHALL BE PROVIDED WHERE NECESSARY IN DEEP TRENCHES OR IN UNSTABLE SOILS. AFTER INSTALLATION HAS BEEN TESTED AND APPROVED, TRENCHES AND EXCAVATIONS SHALL BE BACKFILLED PER STATE AND LOCAL CODES, FREE FROM CLOUDS AND STONES.

MECHANICAL CONTRACTOR SHALL RECORD ALL FIELD CHANGES IN THEIR WORK AS THE JOB PROGRESSES, AND UPON COMPLETION, SHALL TURN OVER TO OWNER A 'RECORD' SET OF PRINTS SHOWING THESE CHANGES.

THE CONTRACTOR SHALL GUARANTEE THAT ALL MECHANICAL SYSTEMS SHALL BE FREE FROM DEFECTS IN WORKMANSHIP, MATERIALS AND PERFORMANCE TO SPECIFIED CAPACITIES AND THAT IF SUCH DEFECTS SHALL APPEAR DURING A PERIOD OF ONE (1) YEAR FROM DATE OF FINAL ACCEPTANCE, THEY WILL REMEDY SUCH DEFECTS TO THE SATISFACTION OF THE ARCHITECT/ENGINEER AT NO EXTRA COST TO THE OWNER, WITHIN A REASONABLE TIME.

SECTION 220500 - COMMON WORK RESULTS

PIPE SLEEVES AND FIRE STOPPING:
 THIS CONTRACTOR SHALL BE RESPONSIBLE FOR FURNISHING, SETTING, AND PROPER LOCATION OF ALL SLEEVES REQUIRED FOR PLUMBING WORK. ALL SLEEVES SHALL BE OF SUFFICIENT SIZE TO PERMIT PIPE MOVEMENT OF EXPANSION AND CONTRACTION, AND TO ACCOMMODATE PIPE INSULATION.

HOLES FOR PIPING THROUGH CONCRETE FLOORS SHALL BE SCHEDULE 40 STEEL PIPE, SECURED TO WALL. SLEEVES ARE NOT REQUIRED FOR CORE-DRILLED OPENINGS.

PIPES SHALL NOT BE INSTALLED THROUGH FOOTINGS, BEAMS, OR COLUMNS EXCEPT AS APPROVED BY STRUCTURAL ENGINEER.

FIRESTOPPING IS DEFINED HEREIN AS THE PROCESS OF FURNISHING AND INSTALLING MATERIAL, OR COMBINATION OF MATERIALS, IN VARIOUS CONSTRUCTION TO MAINTAIN AN EFFECTIVE BARRIER AGAINST THE SPREAD OF FLAME, SMOKE, AND GASES AND TO RETAIN THE INTEGRITY OF TIME-RATED CONSTRUCTION. INSTALL FIRESTOP FOR ALL PIPING PENETRATIONS THROUGH FLOOR SLAB.

SECTION 221000 - PIPING MATERIALS

ALL PIPE AND FITTINGS SHALL BE SMOOTH INSIDE, STRAIGHT, FREE FROM WELD OR SOLDER FLAWS, BLISTERS, OR OTHER DEFECTS. EACH LENGTH OF PIPE AND EACH FITTING SHALL HAVE CAST, STAMPED, OR INDELIBLY MARKED ON IT, THE MAKER'S MARK OR NAME AND THE WEIGHT AND QUALITY OF THE PRODUCT WHERE SUCH MARKING IS REQUIRED BY THE APPROVED STANDARD THAT APPLIES. ALL SIZES SHOWN ON PLANS ARE I.D. REFERENCES TO ANSI AND OTHER STANDARDS SHALL BE LATEST EDITIONS.

PIPING:
 ALL SANITARY WASTE DRAIN PIPES IN BUILDING ABOVE GROUND AND VENTS ABOVE GROUND SHALL BE PVC PLASTIC PIPE.

UNDERGROUND DRAINAGE AND VENT PIPING INSIDE THE BUILDING SHALL BE SCHEDULE 40 SOLID WALL PVC PLASTIC PIPE.

HORIZONTAL SOIL, WASTE, AND DRAIN PIPE SHALL BE SLOPED AT 1/4" PER FOOT EXCEPT WHEN THE PIPE IS LARGER THAN 3" WHICH MAY BE INSTALLED WITH A SLOPE OF NOT LESS THAN 1/8" PER FOOT UNLESS OTHERWISE NOTED.

ALL DOMESTIC WATER PIPING SHALL BE TYPE 'K' SOFT COPPER TUBING CONFORMING TO ASTM B88. INSTALL UNDERGROUND COPPER TUBE IN PE ENCASUREMENT ACCORDING TO ASTM A 674 OR AWWA C105.

FITTINGS:
 PVC FITTINGS FOR PVC PIPING.

FITTINGS FOR RIGID COPPER TUBING SHALL BE WROUGHT COPPER SOLDER FITTINGS CONFORMING TO ANSI B16.22 AND STM B-75.

JOINTS:
 SOLDERED COPPER PIPE JOINTS SHALL USE 95% TIN AND 5% ANTIMONY SOLDER USING A NON-CORROSIVE FLUX.

PVC PIPE JOINTS SHALL BE SOLVENT WELD WITH SOLVENT CEMENT CONFORMING TO ASTM D2855 AND D2564.

VALVES:
 VALVES SHALL BE RATED 200 PSI FOR COLD WATER SERVICE. SOLDER JOINT VALVES SHALL BE RATED 150 PSI FOR WATER SERVICE AT 200°F. UNLESS OTHERWISE SPECIFIED OR INDICATED. ALL VALVES SHALL BE FULL-PORT BALL VALVES.

SECTION 224000 - PLUMBING FIXTURES

PLUMBING FIXTURES SHALL BE FURNISHED AND INSTALLED IN A WORKMANLIKE MANNER WITH PROPER CONNECTIONS TO SUPPLY AND DRAINAGE PIPING. ALL FIXTURES SHALL BE FREE OF DEFECTS AND FLAWS AND SHALL OPERATE PERFECTLY WHEN INSTALLED IN ACCORDANCE WITH THE MANUFACTURER'S DIRECTIONS.

TRAPS:
 EACH FIXTURE AND EACH PIECE OF EQUIPMENT REQUIRING CONNECTION TO THE SANITARY DRAINAGE SYSTEM SHALL BE EQUIPPED WITH WATER-SEALED TRAP. EACH TRAP SHALL BE PLACED AS NEAR THE FIXTURE AS POSSIBLE. TRAPS EXPOSED TO VIEW IN FINISHED SPACES SHALL BE CHROME-PLATED CAST BRASS WITH CLEANOUT. TRAPS INSTALLED ON THREADED PIPE SHALL BE RECESS DRAINAGE PATTERN.

VENT LINES:
 MINIMUM SIZES OF FIXTURE VENTS SHALL BE INSTALLED AS SHOWN IN RISER DIAGRAM ON THE DRAWINGS. CONNECTING VENTS SHALL BE SIZED AND RUN THROUGH ROOF OR CONNECTION TO MAIN VENT SHOWN ON PLANS. VENTS MUST BE CONNECTED INTO STACK VENTS ABOVE HIGHEST FIXTURE.

REVISIONS
 AUGUST 1, 2023
 PROJECT #: 23-09

MECHANICAL SCHEDULES,
 SPECIFICATIONS AND WASTE RISER
 DIAGRAM

PENDER PUBLIC SCHOOLS - SPORTS
 COMPLEX BUILDING
 PENDER, NEBRASKA

PETERS & ASSOCIATES
 ARCHITECTS, P.C.
 SUITE E
 1103 CALVIN ROAD SOUTH,
 BELLEVUE, NEBRASKA
 402-895-2292
 PHONE



M201

For Review Only
 NOT FOR CONSTRUCTION



Engineering - Nebraska COA #CA-0638
 601 P Street Suite 200
 Lincoln, NE 68508
 TEL 402.474.6311
 FAX 402.474.5160
 www.olsson.com

COPYRIGHT 2023
 PETERS AND ASSOCIATES ARCHITECTS P.C. THESE DOCUMENTS ARE ISSUED BY PETERS AND ASSOCIATES ARCHITECTS P.C. AND ARE PROTECTED BY COPYRIGHT LAW. THEY MAY NOT BE REPRODUCED OR DUPLICATED IN WHOLE OR IN PART WITHOUT EXPRESS WRITTEN PERMISSION OF PETERS AND ASSOCIATES ARCHITECTS P.C., BELLEVUE, NE.

8/1/2023 1:20:07 PM BM 300/2500 IPSS - Sports Complex Building ME_Pender Sports Complex_Centris_020-0305.rvt

PENDER PUBLIC SCHOOLS SPORTS COMPLEX BUILDING

PENDER, NEBRASKA

PROJECT NUMBER: 23-09

SPECIFICATIONS

SEPTEMBER 15, 2023

REVIEW SET

SET NO.

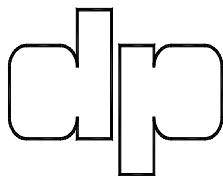

**PETERS AND ASSOCIATES
ARCHITECTS, P.C.**

1103 GALVIN ROAD SOUTH, SUITE E
BELLEVUE, NEBRASKA 68005
PHONE: 402-895-2292

TABLE OF CONTENTS

DOCUMENTS OF BIDDING

NOTICE TO BIDDERS
INFORMATION FOR BIDDERS
FORM OF BONDS
BID FORM

DIVISION 1 - GENERAL REQUIREMENTS

SECTION 1000 - GENERAL CONDITIONS
SECTION 1100 - SUPPLEMENTARY CONDITIONS
SECTION 1110 - SUBMITTALS
SECTION 1200 - PROJECT MEETINGS
SECTION 1300 - SEQUENCE OF CONSTRUCTION
SECTION 1400 - QUALITY CONTROL

DIVISION 2 - SITE WORK

SECTION 2260 - TERMITE TREATMENT
SECTION 2300 - EARTHWORK

SEE NOTES ON CIVIL DRAWINGS

DIVISION 3 - CONCRETE

SECTION 3100 - CONCRETE FORMWORK
SECTION 3200 - CONCRETE REINFORCEMENT
SECTION 3300 - CAST-IN-PLACE CONCRETE
SECTION 3550 - POLISHED CONCRETE FINISH

DIVISION 4 - MASONRY

NOT USED

DIVISION 5 - METALS

SEE TIMBERLYNE DRAWINGS

DIVISION 6 - WOOD AND PLASTICS

SECTION 6100 - ROUGH CARPENTRY
SECTION 6200 - FINISH CARPENTRY
SECTION 6300 - WOOD TREATMENT
SECTION 6650 - SOLID POLYMER FABRICATIONS

DIVISION 7 - THERMAL AND MOISTURE PROTECTION

SECTION 7190 - VAPOR BARRIER
SECTION 7210 - BUILDING INSULATION
SECTION 7221 - NAILBASE INSULATION PANEL
SECTION 7350 - SINGLE PLY ROOFING
SECTION 7411 - METAL PANEL ROOFING SYSTEM
SECTION 7600 - FLASHING AND SHEET METAL
SECTION 7900 - SEALANTS

DIVISION 8 - DOORS, WINDOWS AND GLASS

SECTION 8100 - METAL DOORS AND FRAMES
SECTION 8110 - PREFINISHED STEEL DOOR FRAMES
SECTION 8210 - INTERIOR WOOD DOORS
SECTION 8572 - FIBERGLASS COMPOSITE WINDOWS
SECTION 8700 - HARDWARE
SECTION 8800 - GLAZING

DIVISION 9 - FINISHES

SECTION 9250 - GYPSUM DRYWALL
SECTION 9651 - VINYL BASE
SECTION 9800 - PAINTING
SECTION 9975 - FIBERGLASS WALL PANELS

DIVISION 10 - SPECIALTIES

SECTION 10155 - PLASTIC TOILET COMPARTMENTS
SECTION 10400 - IDENTIFYING DEVICES
SECTION 10520 - FIRE EXTINGUISHERS AND CABINETS
SECTION 10800 - TOILET ACCESSORIES

DIVISION 11 - EQUIPMENT

NOT USED

DIVISION 12 - FURNISHINGS

SECTION 12300 - CABINETS AND COUNTERTOPS

DIVISION 13 - SPECIAL CONSTRUCTION

NOT USED

DIVISION 14 - CONVEYING SYSTEMS

NOT USED

DIVISION 15 - MECHANICAL

ON DRAWINGS

DIVISION 16 - ELECTRICAL

ON DRAWINGS

NOTICE TO BIDDERS

The **Pender Public Schools** of Pender Nebraska, will accept bids for the Pender Public Schools Sports Complex Building located in Pender, Nebraska. The project consists of site work, Construction of a Timberlyne heavy timber building shell with plumbing rough-ins. Interior loft floor and stair structure. Sealed bids for the will be received by the Owner at their offices at 609 Whitney Street, Pender, NE 68047, until 3:00 P.M., Thursday, October 12, 2023. Bids will be publicly opened and read aloud.

The work includes Timberlyn heavy timber building package, with additional items provided by contractor. The building will be approximately 5,050 SF slab. 3,958 square feet enclosed with a 300 square foot loft with outdoor balcony. The building will be bid and completed in two phases. Phase I will be the shell of the building, stairs, loft, and plumbing rough-ins. Phase II will be to complete the interior walls, doors, and finishes. The owner may elect to only do Phase I. All work of this contract will be exempt from Nebraska State Sales Tax.

Contract Documents may be obtained from the Architect, PETERS AND ASSOCIATES, ARCHITECTS, P.C. 1103 Galvin Road South, Suite E, Bellevue, Nebraska 68005, (phone: 402-895-2292), upon payment of a One Hundred Dollar (\$100) refundable deposit, plus a Thirty-Five Dollar (\$35.00) non-refundable shipping and handling fee for each set of Documents, paid in two separate checks. The refundable deposit will be refunded upon the return of the Contract Documents within fifteen (15) days of the bid date, provided they are in good and usable condition.

A digital copy of drawings and specifications may be obtained in PDF format directly from A & D Technical Supply Co., Omaha, Nebraska (www.adtechplans.com) in the form of CD, or they may be downloaded for a cost of \$25.00. For hard copy of plans and specifications, checks for deposit and shipping/handling shall be payable to Peters and Associates, Architects, P.C. For digital copy of plans and specifications, cost of all digital copies whether CD or downloaded shall be payable to A & D Technical Supply.

All copies of the Contract Documents shall be as obtained from the Architect, or directly from A & D Technical Supply. Copyright law applies to all portions of the drawings and specifications. Therefore, no part of the drawings or specifications may be reproduced without express written permission of the Architect. Each bidder shall assure himself that such Contract Documents contain all revisions and changes to date.

Bid Security shall be required in the amount of five percent (5%) of the bid in the form of a Bid Bond issued by a Surety meeting the requirements of the General Conditions.

No Bidder may withdraw his bid for a period of thirty (30) days after the opening of the bids. Alternative items other than those as set forth in the Bid Form will not be considered.

The **Pender Public School** reserves the right to award a contract or contracts in its own best interest, and to reject any or all bids, and to waive any or all informalities or technicalities.

Pender Public School

INFORMATION FOR BIDDERS

1.0 TYPE OF BID

1.01 The **Pender Public Schools** of Pender, Nebraska, (hereinafter called the Owner) will accept bids for the General Construction of the **Pender Public Schools Sports Complex Building**, located in Pender, Nebraska, which is to include Civil Construction, Structural Construction, Mechanical Construction and Electrical Construction, on the form attached hereto. Envelopes containing the bids must be sealed, addressed to and designated as “Bid for the **Pender Public Schools Sports Complex Building**, Pender, Nebraska”.

1.02 The Owner may consider informal any bid not prepared and submitted in accordance with the provisions hereof, and may waive any informalities or reject any or all bids. Any bid submitted after the time and date specified shall not be accepted, opened or considered. No Bidder may withdraw his bid for a period of thirty (30) days after the opening of the Bids.

2.0 PREPARATION AND SUBMITTAL OF BIDS

2.01 The bid must be submitted on the prescribed form. All blank spaces shall be filled in with ink or be typewritten, in both words and figures, and must be fully completed and executed when submitted.

2.02 Each bid must be submitted in a sealed envelope bearing on the outside the name of the Bidder, his address, and the name of the project for which the bid is submitted. If forwarded by mail, the sealed envelope containing the bid must be marked “sealed bid,” to insure that it not be opened until the bid time and date.

3.0 QUALIFICATION OF BIDDERS

3.01 At the Owner’s request, each Bidder must be prepared to submit, within five days, written evidence of the types specified to demonstrate qualifications to perform the work. The Owner reserves the right to reject any bid if the evidence submitted by the Bidder, or if investigation of the Bidder fails to satisfy the Owner that such Bidder is properly qualified to carry out the obligations of the contract and to complete the work. Conditional bids will not be considered. By submitting a bid the Bidder acknowledges that he is authorized to do business in the State of Nebraska, and that he meets all laws, regulations, and ordinances pertaining thereto.

4.0 EXAMINATION OF CONTRACT DOCUMENTS AND SITE OF THE WORK

4.01 The Contract Documents, including the Drawings and Specifications as instruments of service, are the property of the Architect, and may not be used for any other project without written permission from the Architect. All copies of the Contract Documents must be returned to the Architect upon completion of the Contract.

4.02 Before submitting a bid, each Bidder shall examine the Contract Documents thoroughly, visit the site of the work to become familiar with conditions which may affect in any manner the cost, progress or performance of the work, and familiarize himself with all Federal, State, and local laws, ordinances, rules and regulations which may in any manner affect the cost, progress or performance of the work. The submission of a bid shall be construed as conclusive evidence that the Bidder has made all such examinations.

4.03 All Contract Documents used for construction purposes shall be obtained by the Contractor directly from the Architect or from A & D Technical Supply before commencing construction, and the Contractor is responsible for verifying that such Contract Documents contain all revisions and changes to date.

5.0 BID SECURITY

5.01 Bid Security shall be submitted with each bid in the amount of five percent (5%) of the bid, and shall be in the form of a certified check, payable to the Owner, or a Bid Bond issued by a Surety meeting the requirements of the General Conditions.

5.02 The Bid Security of unsuccessful bidders will be returned within fifteen days of the bid date. The Bid Security of the Successful Bidder will be retained by the Owner until the Bidder has executed the Agreement and

furnished the required Performance and Material and Labor Payment Bonds, at which time it will be returned. If the successful bidder fails to furnish the required Security for the faithful performance of the work, within ten days after the Notice of Award, the Owner may declare the Notice of Award null and void, and the Bid Security of that bidder will be forfeited.

6.0 CLARIFICATIONS, INTERPRETATIONS AND ADDENDA

No interpretations of the meaning of the Contract Documents will be made orally, but requests for such interpretations shall be made in writing to the Architect, and to be given consideration, must be received by the Architect at least ten (10) days prior to bid date. Interpretations and clarifications from the Architect shall be in the form of a written addenda, and if issued, will be mailed to all prospective bidders and plan holders not less than three days prior to the bid date. At the Architect's discretion, addenda may be issued within three days of bid date, and if issued may be done so via electronic mail or fax transmission. Failure of the Bidder to include consideration of addendum in his bid shall not relieve such Bidder of any obligation under his bid. All addenda so issued shall become a part of the Contract Documents.

7.0 SUBSTITUTIONS

7.01 All Bids shall be based on the use of only those materials and methods as specified, or which have been added through written addendum. Identification of material and equipment by a single manufacturer is not meant to give preference to any one manufacturer, or to limit competition, but is merely to establish a standard of quality.

7.02 To obtain approval to use products which have not been specified, the Contractor shall submit written requests, clearly describing the product for which approval is sought, including all data necessary to demonstrate acceptability and comparison to specified products. Requests for approval, to be given consideration, must be submitted at least ten (10) days prior to the date of bid. Request received after that time will not be considered. If the product is deemed to be acceptable by the Architect, the Architect shall approve it through a written addendum.

8.0 CONDITIONS OF THE WORK

8.01 The Bidder must inform himself fully of the conditions relating to the construction of the project, and the employment of labor thereon. Failure to do so will not relieve the Contractor or Subcontractor of his obligation to furnish all necessary labor, material, and equipment to carry out the provisions of the contract. Insofar as possible, the Contractor, in carrying out the work shall employ such methods or means as will not cause any interruption or interference with the work of any other Contractor or Subcontractor.

9.0 CONTINGENCY FUND

9.01 The Owner shall set aside a contingency fund in the amount of 2% of the total contract amount, which shall be included in the construction contract as a line item. The contingency fund shall be available to cover the cost of unforeseen items or required items which are not indicated on the original construction documents but become known during construction of the project, including but not limited to, existing conditions, coordination of mechanical, electrical, structural and architectural items between the trades, routing of systems, piping, conduits and ductwork, items or components determined to be required for the project, clarification of details and supplemental instructions. The contingency fund shall not be used for changes to the project of the Owner's discretion. At the completion of the project, unused amounts of the contingency fund will be credited back to the Owner.

9.02 The contingency fund shall not be included on the bid form, but will be added at the time the construction contract is written.

10.0 BID OPENING

10.01 Bids will be received at the date, time and place as indicated in the Notice to Bidders. Any bid submitted after that time will not be accepted or considered. The Bids will be publicly opened and read aloud.

11.0 AWARD OF CONTRACT OR REJECTION OF BID

11.01 The Contract will be awarded to the responsible bidder who submits the lowest bid which complies with the conditions of the Contract Documents, provided his bid is reasonable and it is in the best interest of the Owner to award the Bid. The successful bidder will be notified at the earliest possible date. The Owner reserves the right to reject any or all bids, and to waive any informalities in any bids received, whenever such action is in the best interest of the Owner.

12.0 PERFORMANCE AND PAYMENT BONDS

12.01 Subsequent to the award of the contract and within ten (10) days after the prescribed forms are presented for signature, the Contractor shall execute and deliver to the Architect, in triplicate, a Contract in the form prescribed herein. Having satisfied all conditions of award as set forth elsewhere in these Contract Documents, the successful Bidder shall, within the period specified above, submit to the Architect, in duplicate, a Performance Bond and Labor and Material Payment Bond in a penal sum of at least the full amount of the contract sum as awarded, in the form included herein, which secures the faithful performance of the contract, and for payment of persons, firms, or corporations to who the contractor may become legally indebted for labor, materials, tools, equipment, or services, of any nature, employed or used by him in performance of the work. Such Bonds shall bear the same date as, or a date subsequent to the Contract. Bonds shall be issued by a surety company licensed to do business in the State of Nebraska and acceptable to the Owner.

12.02 The current power of attorney for the person who signs for any surety company shall be attached to all bonds submitted.

12.03 The Contractor shall use the above prescribed Bonds for security for faithful performance, and no other means of security for faithful performance shall be allowed.

13.0 TAXES

13.01 This project is **exempt** from Federal Excise Tax, and all State and Local Sales Taxes, and each bidder shall **exclude** from his bid, all such taxes. The Owner will provide a tax exempt certificate to the general contractor for use by the general contractor, all subcontractors and all material suppliers.

14.0 FORM OF AGREEMENT

14.01 The Contractor shall execute a contract with the Owner on the "Standard Form of Agreement Between Owner and Contractor, AIA Document No. A101", for a stipulated sum. A copy of said agreement is available for examination at the office of the Architect.

15.0 TIME OF COMPLETION

15.01 The time of completion for this project is of the essence, and shall be as set forth in the Bid Form.

16.0 INSURANCE

16.01 The Contractor shall take out and maintain during the life of the Contract, insurance in the kinds and amounts as set forth in the General Conditions and Supplementary Conditions. The Contractor shall furnish to the Owner, certificates of insurance giving evidence that the required coverage has been obtained.

17.0 LAWS AND REGULATIONS

17.01 Each bidder's attention is directed to the fact that all applicable Federal, State and local laws and ordinances, and the rules and regulations of all authorities having jurisdiction over construction of the project shall apply to the contract throughout, and they will be deemed to be included in the contract the same as though herein written out in full.

18.0 WAIVERS OF LIEN

18.01 Lien waivers shall be submitted by the General Contractor and each subcontractor and material supplier at the completion of the project. Waiver of lien shall be executed on a form as approved by the Architect.

FORM OF BONDS

1.0 FORM OF BONDS

1.01 The following forms for bonds shall be used for this project. No other form of bonds shall be permitted.

2.0 PERFORMANCE AND LABOR AND MATERIAL PAYMENT BOND

2.01 Performance Bond and Labor and Material Payment Bonds for this project shall be submitted on American Institute of Architects Standard Form of Performance Bond and Labor and Material Payment Bond (A.I.A. Document A312).

3.0 SOURCE OF FORMS

3.01 A copy of these documents are available from the office of the Nebraska Society of Architects, Lincoln, Nebraska (phone: 402-472-1456).

BID PROPOSAL FORM
FOR GENERAL CONSTRUCTION

for the **Pender Public Schools, Sports Complex Building**, located in Pender, Nebraska.

Date: _____

From: _____
(hereinafter called the Contractor),

To: **Pender Public Schools** (hereinafter called the Owner).

1. CONTRACT DOCUMENTS. The Bidder acknowledges that he has received and familiarized himself with the following Contract Documents as prepared by PETERS AND ASSOCIATES, ARCHITECTS, P.C.:

Drawings, including Cover, Sheets C.1, C.2, C.3, C.4, C.5, A-1.1, A-1.2, A-1.3, A-1.4, A-2.1, A-2.2, A-3.1, A-3.2, A-4.1, A-6.1, A-7.1, S1, S2, S3, S4, S5, S6, S7, S8, S9, S10, S11, S12, S13, S14, S15, S16, S17, S18, S19, S20, S21, S22, S23, S24, M101, M201, dated September 7, 2023.

Specifications, dated September 7, 2023.

2. ADDENDA. The Bidder acknowledges receipt of Addendum _____ through _____.
3. The undersigned, having familiarized himself with the Contract Documents, and the local conditions affecting the cost of the work at the place where the work is to be done, hereby proposes and agrees to perform everything required to be performed and to furnish all labor, materials, and equipment, and all utility and transportation services necessary to perform and complete all the work required as shown on the Contract Documents for the construction of the Pender Public School, Sports Complex Building, located in Pender, Nebraska,
4. The Bidder agrees to hold his bid open for a period of Thirty (30) days after the Bid Date.
5. The Bidder agrees to enter into a contract with the **Pender Public Schools** in the form as prescribed, if awarded on the basis of this bid, and to furnish a Performance and Labor and Material Payment Bond in accordance with the Specifications within ten (10) days after the award of contract.
6. The Bidder agrees to commence work on the project within fifteen (15) days of the notice to proceed, and to achieve Final Completion within _____ (_____) calendar days. (Contractor enter in calendar days.)
7. **The Bidder understands and agrees with the provisions for liquidated damages as set forth in the Specifications.**
8. BASE BID. The undersigned hereby proposes and agrees to perform the work for the sum of:
_____ Dollars

(_____). The amount shall be shown in both words and figures. In the case of a discrepancy, the amount shown in words shall govern.)

(Note: All Federal Excise taxes and State and local Sales Taxes are **excluded from** this proposal.)

9. In submitting his bid, the Bidder agrees and understands that the right to reject any or all bids, and to waive any informalities in the bidding is reserved by the Owner.

This Proposal dated this _____ day of _____, 2023.

Name of Bidder: _____

Address: _____

Phone Number: _____

Submitted by: _____

(signature of authorized officer)

Title: _____

SECTION 1000

GENERAL CONDITIONS

1.01 STANDARD FORM

1.01.1 The "General Conditions of the Contract for Construction" AIA Document No. A201, 2017 edition, shall constitute the general conditions of this Contract. A copy of this document is available from the Nebraska Chapter, American Institute of Architects, Lincoln, Nebraska (phone: 402-858-1929).

1.01.2 The General Conditions document shall have the same force and effect as if it were herein written out in full. Where Supplementary Conditions of the Specifications are at a variance with the General Conditions, the Supplementary Conditions shall take precedence.

SECTION 1100

SUPPLEMENTARY CONDITIONS

1.01 DRAWINGS AND SPECIFICATIONS

1.01.1 In the case of a discrepancy between the drawings and specifications, or an inconsistency within the drawings or specifications, or between the contract documents and existing conditions, the matter shall promptly be brought to the attention of the Architect, who shall make an interpretation in writing as to the intent of the Contract Documents. Any adjustment by the Contractor without this determination shall be made at his own risk and expense.

1.01.2 The Architect, as author of the Contract Documents, shall be the sole interpreter of the intent of the Contract Documents. In accordance with the General Conditions the Architect's interpretations and decisions will be consistent with the intent of and reasonably inferable from the Contract Documents.

1.02 INSURANCE

1.02.1 The Contractor shall maintain and furnish evidence of insurance coverage as required in the General Conditions, and as set forth herein. This insurance shall be written for not less than the following amounts:

Workers' Compensation

- 1) State: Statutory
- 2) Employer's Liability: \$500,000

Comprehensive General Liability:

- 1) Bodily Injury: \$500,000 Each Occurrence
\$500,000 Annual Aggregate
- 2) Property Damage: \$500,000 Each Occurrence
\$500,000 Annual Aggregate
- 3) Personal Injury, with employment exclusion deleted:
\$500,000 Annual Aggregate

Comprehensive Automobile Liability:

- 1) Bodily Injury: \$500,000 Each Person
\$500,000 Each Accident
- 2) Property Damage: \$500,000 Each Occurrence

Contractual Liability:

- 1) Bodily Injury: \$500,000 Each Occurrence
- 2) Property Damage: \$500,000 Each Occurrence
\$500,000 Annual Aggregate

Umbrella Liability \$2,000,000

1.03 BUILDER'S RISK INSURANCE

1.03.1 The Owner shall maintain Builder's Risk insurance during the construction of the project, which shall be in effect from the start of construction until completion of the project and acceptance by the Owner.

1.04 PERMITS, FEES AND REQUIRED INSPECTIONS

1.04.1 The contractor shall obtain all building permits, fees, and any inspections required by the City of Pender any state and local authority having jurisdiction. Each Subcontractor shall be responsible for taking out permits as may be required for his portion of the work.

1.04.2 The Contractor shall be responsible for payment of all capital improvement charges, capital facilities charges, connection charges, tap fees, meter fees or any other fees or charges assessed by any utility company serving the project for connection and service by such utility.

1.05 LAYING OUT THE WORK

1.05.1 The Contractor shall locate all general reference points and take such actions as necessary to prevent their destruction, lay out his own work and be responsible for all lines, elevations, and measurements of buildings, utilities and other work in the Contract. Contractor shall verify all dimensions and figures relative to existing conditions before laying out the work, and will be responsible for any error resulting from his failure to exercise such precautions.

1.05.2 The Contractor shall retain the services of a licensed land surveyor or a registered civil engineer to locate components of the project relative to property lines, finish floor elevations of buildings, and elevations of all elements of paving and drainage.

1.06 PROTECTION OF EXISTING STRUCTURES AND WORK

1.06.1 Any damage to existing structures or work of any kind, or interruption of a utility line shall be repaired or restored promptly at the expense of the Contractor.

1.07 SAFETY REQUIREMENTS

1.07.1 The Contractor shall be responsible for the protection and safety of all persons and property and shall comply with all applicable provisions all Federal, State, and local safety laws.

1.08 GUARANTEES

1.08.1 All new work shall be guaranteed for a period of one year from the date of substantial completion against defects resulting from the use of materials, equipment or workmanship. If repairs are required in connection with the work, the Contractor shall correct all work which is inferior, and make good all damages to the project, site, equipment or contents of the building.

1.09 DELIVERY AND STORAGE OF MATERIALS

1.09.1 The Contractor shall make arrangements for the delivery and storage of materials, and shall make the required arrangements for the delivery, storage and incorporation of materials of Subcontractors into the project. Materials shall be delivered at such stages of the work as will expedite the work, and shall be marked and stored in such a manner as to be easily checked and inspected.

1.10 SUBSTITUTIONS

1.10.1 The Contract shall be based on the use of only the materials, equipment and methods specified in the Contract Documents.

1.10.2 The Architect may consider substitutions for materials, equipment or methods other than those specified in the Contract Documents provided requests for substitutions are submitted to the Architect no later than 10 days before the date of bid opening. Requests for substitutions shall be submitted in hard copy via U.S. Mail, UPS (or similar courier), e-mail, or shall be hand delivered. Requests for substitutions submitted via fax will not be considered. All approvals for substitution will be authorized by written addenda only.

1.10.3 Items which are approved by the Architect by written addendum shall be deemed acceptable in terms of general conformity with the intent of the contract documents. It shall be the responsibility of the general contractor and/or his subcontractor or material supplier to ascertain that all factors of the products submitted for substitution meet or exceed those of the specified products, including performance, function, capacities, operation, mechanical and/or electrical requirements and physical size, in order that the item may be installed as that originally specified, without modifications to the building or its components as designed by the architect.

1.11 TEMPORARY FACILITIES

1.11.1 Temporary Facilities shall be provided as indicated below:

- .1 The Contractor shall provide temporary toilets and shall maintain them in a clean and sanitary condition for use by all persons working on the project.
- .2 A temporary field office shall be maintained at the site, and shall be equipped with heat, telephone, plan desk, and shall be of sufficient size for the use of the Contractor, the Architect, and other agencies during their periodic inspections or observations of the project.
- .3 The Contractor shall provide temporary heat in the building as required by seasonal conditions to facilitate the timely completion of the work. Temporary heaters which are to be used during installation and finishing of gypsum drywall and other interior finishes shall be vented type heaters, which vent products of combustion to the outside, and provide vapor free heat in the building. Temporary heaters shall provide for proper distribution, to maintain required temperatures throughout the structure. Provide individual heaters in small rooms as required. The permanent building heating systems MAY NOT BE USED FOR TEMPORARY HEATING, until, finish of all gypsum drywall work is complete. If the building heating systems are to be utilized prior to acceptance of the building by the Owner, specific provisions shall be made for roughing pre-filters and other requirements to prevent accumulation of dust and debris in equipment and ductwork. Written approval shall be obtained from the equipment manufacturer by the Contractor, with written concurrence of the heating, ventilating and air-conditioning subcontractor, indicating that the warranty of the equipment will not be adversely affected, with concurrence by the Owner and Architect. The costs for all temporary heating including fuel, shall be borne by the Contractor. Prior to acceptance of the building by the Owner, the Contractor shall thoroughly clean all equipment and ductwork of all dust and debris as a result of utilization of the equipment during construction.

1.12 TEMPORARY UTILITIES

1.12.1 Temporary power for the project may be obtained from the existing building electrical service. The contractor shall be responsible for installation and maintenance of all elements of electrical components required to facilitate completion of the work including all wiring, poles, panels and installation costs, as required to facilitate the timely completion of the work. The cost of temporary power shall be borne by the Owner.

1.12.2 Temporary water for the project may be obtained from the existing building water system. Coordinate with the Owner to assure that the Owner's use of water will not be encumbered by use of the Contractor. The cost of temporary water shall be borne by the Owner.

1.12.3 All temporary utilities shall be installed and maintained in accordance with all applicable codes, standards, and regulations. The cost of all temporary utilities shall be borne by the Owner.

1.13 CLEANING UP

1.13.1 The contractor shall at all times keep the premises free from accumulation of waste material or rubbish as a result of the work. All waste shall be collected and placed in proper containers at the end of each work day, and shall be disposed of properly. At the completion of the project, the Contractor shall thoroughly clean the areas of the building in which work has been completed, so that the building may be utilized by the Owner without having to be cleaned again. Specific requirements shall be as indicated in the Specifications.

1.14 APPLICATION FOR PAYMENT

1.14.1 Application for Payment will be considered once each month. The Contractor shall submit Applications for Payment to the Architect no later than the first day of each month for work completed and material stored as of the previous month, in accordance with the General Conditions. Applications for Payment shall be prepared on AIA form, "Application and Certificate for Payment", AIA Document No. G702, and shall be signed by the Contractor, notarized, and submitted in TRIPLICATE to the Architect.

1.14.2 The Architect shall review Applications for Payment, verify that the amounts applied for do reflect actual work completed and material suitably stored, and shall submit to the Owner an approved application for payment, within seven days of receipt of Application for Payment. Payment shall be made in the amount of Ninety percent (90%) of the value of the work in place and material suitably stored, within twenty (20) days of the approval of the Application for Payment by the Architect, with ten percent (10%) being withheld as retainage until completion of the work.

1.14.3 Upon final completion of the entire project, final inspection and acceptance of the work by the Owner, in accordance with the General Conditions, the Owner will pay to the Contractor, the balance of the Contract Sum as recommended by the Architect.

1.15 PROJECT CLOSEOUT

1.15.1 When the Contractor determines that the work is substantially complete, he shall prepare a punch list itemizing those items which need to be corrected or completed, and submit the punch list to the Architect.

1.15.2 The Architect will then inspect the project, and when he determines that the project is substantially complete, will issue a Certificate of Substantial Completion, and shall establish a time period within which the Contractor shall complete the items listed on the punch list.

1.15.3 When the Architect determines that the work is ready for final inspection, and upon receipt of the Final Application for Payment, he will conduct a final inspection of the project. If the project is complete, the Architect will issue a Final Certificate for Payment. At that time, one hundred percent (100%) of the Contract Sum will be paid to the Contractor.

1.15.4 The Contractor shall submit the following documents and information to the Architect at the time of submission of the Final Application for Payment, in accordance with the General Conditions.

- .1 Waiver of Lien from the General Contractor for the full amount of the contract sum.
- .2 Waivers of Lien from all subcontractors and material suppliers for subcontracts over \$1,000 for the full amount of each subcontract sum.
- .3 Consent of Surety to Final Payment
- .4 All maintenance and operating manuals, instructions, project record documents, required certificates of inspection, guarantees, and bonds.

1.16 AS-BUILT DRAWINGS

1.161 The Contractor shall maintain one complete set of Contract Documents at the Construction Site suitably marked to show all deviations from the original Documents. As built drawings shall be turned over to the Owner at the time of closing.

1.17 PROJECT SUPERVISION

1.17.1 The Contractor shall provide a full-time project superintendent who shall be assigned to this project only, for the duration of the project. Project superintendent shall be on the project site during normal working hours, except during periods when the project is shut down due to severe weather conditions which preclude any construction activity, with prior approval of the Architect.

1.18 REFERENCED STANDARDS

1.18.1 Included in the drawings and specifications are referenced standards for construction assemblies and/or components which have been tested and approved by American Society of Testing Materials (ASTM), Underwriters Laboratories (UL), Gypsum Association (GA) or Factory Mutual (FM). Where such standards are referenced in these construction documents, the contractor shall be responsible for compliance with all aspects of the referenced standard, including materials, spacings, installation, and all other aspects of the referenced standard.

1.19 CHANGES TO THE WORK

1.19.1 In the event that changes in the work are requested by the Architect, changes to the work shall be accomplished in accordance with provisions of the General Conditions, except as modified herein. If changes in the work are determined to be required, changes shall be fully discussed between the Contractor, Architect and the Architect's Consulting Engineers. No changes to the work shall be completed prior to written approval of the Architect. The Contractor shall prepare costs for such changes to present to the Architect in accordance with the General Conditions. If the changes result in an increase in the cost of the work, the Architect shall obtain authorization from the Owner for any increase in cost, and the Contractor shall not proceed with such changes without written authorization from the Architect. If the Contractor proceeds with changes in the work without obtaining such written authorization, any increased cost of the work shall be at the Contractor's expense.

1.19.1 For proposed changes to the work which result in an increase in construction cost, the cost of changes shall include the net cost of the change, plus a maximum of fifteen percent (15%) for combined overhead and profit for the Subcontractor, and a maximum of fifteen percent (15%) for combined overhead and profit for the General Contractor. For proposed changes to the work which result in a decrease in cost, the cost of changes shall include the net cost of the deduction only, without any adjustments in overhead and profit.

1.20 ASBESTOS CONTAINING MATERIALS

1.20.1 It is the intention of these specifications that no materials, components, assemblies or manufactured items that have been specified, detailed or otherwise designated to be incorporated into the project contain any asbestos. It shall be the responsibility of the general contractor, each of his subcontractors and materials suppliers to certify that no materials, components, assemblies or manufactured items supplies for incorporation into this project contain any asbestos. Upon completion of the project the general contractor shall submit a certification to that effect.

SECTION 1110

SUBMITTALS

1.01 CERTIFICATES OF INSURANCE

1.01.1 The Subcontractor shall submit Certificates of Insurance to the Construction Manager as required in the General Conditions and Supplementary Conditions at the time of delivery of the executed Agreement. All insurance taken out by the Subcontractor for this project shall name the Owner and the Architect as additionally insured.

1.02 SCHEDULE OF VALUES AND CONSTRUCTION SCHEDULE

1.02.1 Within ten days after receiving the Notice of Award, the Contractor shall submit to the Architect the following:

- .1 A Schedule of Values, which indicates a breakdown of the project costs as per various trades and sections of the work. Schedule of Values shall be submitted on the Application for Payment form.
2. A Construction Schedule containing:
 - 1) Sequence of the work.
 - 2) Time for starting and completion of each part of the work.
 - 3) Coordination requirements between work requirements.
- .3 A cash flow projection indicating an estimate of monthly Applications for Payment. Provide a breakdown of major items as per work task or trade division.

1.03 LIST OF SUBCONTRACTORS AND MATERIAL SUPPLIERS

1.03.1 The Construction Manager shall submit a list of Subcontractors and Material Suppliers to the Architect at the time of delivery of the executed Agreement.

1.04 SHOP DRAWINGS – GENERAL

1.04.1 The Construction Manager shall submit shop drawings to the Architect as specified herein. Shop drawings shall be submitted for all materials and equipment as indicated in individual specification sections. Any items incorporated into the work without proper review of shop drawings will be at the risk of the Subcontractor

1.04.2 Shop Drawings shall first be reviewed by the Construction Manager, to determine performance criteria, dimensions, quantity, and general conformance with the Contract Documents, initialed by the Contractor indicating they have been reviewed, and then submitted to the Architect. Shop Drawings submitted without indication of Contractor review will be returned without review. Approval of Shop Drawings by the Architect shall indicate that the material or equipment complies with the Contract Documents in regard to general quality and performance, but does not relieve the Construction Manager and Contractor of the responsibility for dimensions, quantity, and other aspects.

1.04.3 Shop drawings shall be numbered in sequence, and the numbering system coordinated with the Architect.

1.04.4 Shop drawings will be processed by the Architect and his consultants as expeditiously as practical. Allow minimum of two (2) weeks for approval of shop drawing which are to be reviewed by the Architect only, and minimum of three (3) weeks for shop drawings which are to be reviewed by consulting engineers.

1.05 SPECIAL SUBMITTAL REQUIREMENTS

1.05.1 All shop drawings shall be submitted digitally via email. Contractor may elect to use a digital submission service like BIM 360/Build or Submittal Exchange. Cost of access for Contractors, Architect, Consultants and Owner to be paid by contractor.

1.06 SHOP DRAWINGS – HARD COPY

1.06.1 For Shop Drawings items which cannot be submitted electronically such as samples for color, materials and finishes, samples shall be submitted as hard copy, with transmittal and reference on Submittal Exchange. The Contractor shall submit a minimum of three samples to the Architect.

1.06.2 Shop Drawings submitted as hard copy shall be submitted via U.S. Mail, UPS or courier, or they may be hand delivered.

SECTION 1200

PROJECT MEETINGS

1.01 PRE-CONSTRUCTION CONFERENCE

1.01.1 A pre-construction conference will be held after the Agreements with the Contractors are executed, but before any work on the project has begun. The intent of the conference will be to review the project, discuss and clarify administrative procedures and requirements, and to establish a working understanding among all parties involved in the project.

1.01.2 A representative of the following parties shall be required to attend the pre-construction conference:

- .1 The Owner
- .2 The Construction Manager
- .3 All major Prime Contractors
- .4 The Architect

1.02 PROGRESS MEETINGS

1.02.1 Progress meetings shall be scheduled at one month intervals during the course of the project, and shall be as scheduled by the Construction Manager. Additional meetings may be scheduled at the request of the Construction Manager, Owner or Architect.

1.03 MONTHLY MEETINGS WITH THE OWNER

1.03.1 A monthly meeting shall be scheduled between the Owner, Construction Manager and Architect during the course of the construction, to review progress of the construction, to review application for payment, and to answer specific questions in regard to the project.

1.04 PLACE OF MEETING

1.04.1 All project meetings shall be held at the project site.

SECTION 1400

QUALITY CONTROL

1.0 TESTING LABORATORY SERVICES

1.01 The Contractor shall retain a competent Testing Consultant to perform the necessary quality control tests as specified in other sections of these specifications. The Contractor shall coordinate and schedule the services of the Testing Consultant on behalf of the Owner.

2.0 SAMPLING AND TESTING

2.01 All sampling and testing shall be performed by the Testing Consultant's authorized representative, except as indicated otherwise. The location from which the samples were taken and tests performed shall be recorded and noted in the test reports.

3.0 TESTING REPORTS

3.01 All reports shall be made in triplicate with two copies sent directly to the Architect, and one copy sent to the Contractor. In addition, copies of concrete testing reports shall be submitted to the concrete supplier.

4.0 REQUIRED TESTS

4.01 Tests are specified for the following sections, and requirements for each are specified within each respective section:

Section 2300	Earthwork
Section 3300	Cast in Place Concrete

4.02 The cost for testing shall be borne by the Contractor.

5.0 SPECIAL INSPECTIONS

5.01 Special inspections are required as indicated on the structural drawings. The Owner shall retain a company certified to perform special inspections. The Contractor shall coordinate and schedule the special inspection services on behalf of the Owner. Special inspections are required for the following:

- .1 Concrete
- .2 Reinforcing steel
- .3 Structural steel

5.02 The cost for special inspections shall be borne by the Owner.

SECTION 2260

TERMITE TREATMENT

1.0 GENERAL

1.01 STANDARDS AND QUALIFICATIONS

1.01.1 Chemical soil treatment material and procedure shall comply with current FHA Minimum Property Standards, Publication NO. 300, with recommendations contained in USDA H & A Bulletin No. 64, "Subterranean Termites, Their Prevention and Control in Buildings", and these specifications.

1.01.2 Application of termite treatment shall be by a licensed exterminating contractor, who is familiar with the procedures for the work, and all applicable State, Federal and local codes and regulations affecting the application of the materials, and who is normally in the business of providing extermination and pest control. Under NO CIRCUMSTANCES will application by the Contractor be allowed.

1.02 JOB CONDITIONS

1.02.1 Environmental Conditions. Do not apply working solution when soil and fill are frozen or excessively wet, or immediately after heavy rain.

1.02.2 Protection. Do not disturb treated areas during subsequent construction operations, or permit slabs to be placed sooner than 12 hours after treatment of the soil.

1.02.3 Scheduling. Termite treatment shall be "pre-construction" treatment, as specified herein. At contractor's option "post treatment" may be used, provided all guarantees and warranties will remain the same as those for "pre-treatment".

- .1 Begin soil treatment work only after all preparations for slab placement have been completed. Complete treatment prior to placement of vapor barrier under slab on grade.
- .2 Begin foundation wall treatment only after footings, foundation walls and other foundation work, including under slab plumbing are complete.
- .3 Begin backfill treatment only after backfilling is complete.
- .4 Coordinate soil treatment with related work of other trades. If construction in any area is placed before specified treatment is made, provide post-construction treatment at specified rates.

1.03 SUBMITTALS

1.03.1 Guarantee. Submit in duplicate to the Architect, a guarantee which states that the application was made at concentrations, rates, and methods which comply with the minimum requirements of these specifications. The guarantee shall be drawn in favor of the Owner, and its successors and assigns for a period of five years, and shall be non-cancelable. If subterranean termite activity becomes evident in or under the building during the guarantee period, the exterminator shall promptly, and without expense to the Owner, retreat the soil and make good the damages caused by the termite activity, limited to ten thousand dollars (\$10,000) maximum repair with proof of active termite damage.

2.0 PRODUCTS

2.01 CHEMICALS

2.01.1 Use only chemicals formulated as an emulsible concentrate for subsequent dilution with water, and those which are approved for use by all governing agencies having jurisdiction. Fuel oil will not be permitted as a diluent.

3.0 EXECUTION

3.01 LOCATION AND RATE OF APPLICATION

3.01.1 Under interior and/or attached exterior slabs on grade, apply one gallon of toxicant per 10 square feet over earth fill.

3.01.2 Along foundation walls, apply four gallons of toxicant per 10 lineal feet to both the inside and outside of the wall, to treat the top one foot of the soil.

3.01.3 Around plumbing lines, and along both sides of interior bearing walls, apply four gallons of toxicant per 10 lineal feet.

3.02 METHODS OF APPLICATION

3.02.1 At slabs on grade, apply toxicant with spray equipment.

3.02.2 At backfilled areas, apply toxicant with soil injector rod. Insert the rod at 12 inch intervals at a distance not to exceed 6 inches from the wall. Penetrate the rod to within 6 inches of the top of the footing.

3.03 CONTRACTOR'S OPTION

3.03.1 At Contractor's option, post treatment may be used in lieu of treatment specified above, provided the guarantee against termite activity and damage are as specified herein.

SECTION 2300

EARTHWORK

1.0 GENERAL

1.01 SCOPE OF WORK

1.01.1 Work required under this section shall include all earthwork required to complete the work including but not limited to site stripping, removal of underground obstructions, excavation for construction, overexcavation, backfilling, and grading. Contractor shall dispose of any unsuitable materials from the job site at a site approved by the Owner and Architect. The cost of loading and hauling material to and from the job site, the conditioning of fill material to reach optimum moisture content and compaction shall be borne by the Contractor.

1.04 LINES AND GRADES

1.04.1 Contractor shall carefully maintain all bench marks, monuments and other reference points and replace same if disturbed.

1.04.2 Complete earthwork in a manner such that groundline elevations, building elevations and paving surfaces and elevations are achieved as indicated. Allow for granular fill, slabs, topsoil, etc. as necessary.

1.05 TESTING AND INSPECTION

1.02.2 1.05.1 All earthwork shall be under the surveillance of the Soils Engineer to verify compliance with the specifications. Soil density tests shall be taken by the Soils Engineer for each lift of fill and backfill shall be tested. The frequency of testing shall be as necessary to insure compliance with the specifications. Test and Inspection reports shall be submitted to the Contractor, Architect and Owner on a weekly basis. It shall be the responsibility of the Contractor to notify the Soils Engineer in sufficient time for the Soils Engineer to be present to required surveillance, inspection and testing. In general, the service of the Soils Engineer shall include, but may not be limited to the following:

- .1 Determine that all undesirable material is removed.
- .2 Observe excavations.
- .3 Observe, measure and approve scarification and compaction. Proofrolling.
- .4 Approve quality of fill and backfill materials.
- .5 Observe, measure and approve density of compacted fill, including backfill.
- .6 Provide moisture density of compacted fill, including backfill.
- .7 Inspect footing excavations.
- .8 Evaluate and approve methods and equipment used for earthwork.
- .9 Identify excavated soils which are contaminated and in need of disposal.

2.0 PRODUCTS

2.01 FILL MATERIAL, GENERAL

2.01.1 Required Approval. All fill material shall be subject to the approval of the Soils Engineer. For approval of imported fill material, notify the Soils Engineer at least four working days in advance of intention to import fill material, designate the proposed borrow area for the purpose of making acceptance test to prove the quality of the material.

2.01.2 Imported Fill used on this site should conform to the requirements of structural fill (Section 3.09), be free of organic or other deleterious materials, have a particle size less than 1 ½", have a liquid limit of less than 43 percent and a plasticity index of less than 23.

2.01.3 Backfill. All backfill, including backfill for trenches, shall meet the requirements for fill.

2.01.4 Granular Fill. Granular fill shall be similar to NDOT Type 5 crushed limestone aggregate and approved by the Soils Engineer.

3.0 EXECUTION

3.01 GENERAL

3.01.1 Familiarization. Before the work is started, become thoroughly familiar with the site conditions and all other factors which may affect the work. Take all such conditions and factors into consideration.

3.01.2 Approvals. Complete all evaluations and obtain approvals for proposed methods and materials by Soils Engineer before starting the work. If for any reason after work is started, materials or methods other than those already approved are to be considered, additional evaluations and approvals shall be obtained.

3.01.3 If for any reason, work is completed or partially completed without having first obtained the required evaluations and approvals by the Soils Engineer, or the work has not been tested and inspected by the Soils Engineer at the time and in the manner necessary for him to evaluate and approve the completed or partially completed work, or if the work fails to obtain the required approvals, the work shall be removed and properly replaced, at no additional cost to the Owner.

3.01.4 Use appropriate equipment to avoid disturbing the site as outlined in the geotechnical report.

3.02 PROTECTION OF PERSONS AND PROPERTY

3.02.1 Barricade open excavations occurring as part of this work and post with warning lights.

.1 Operate warning lights as recommended by authorities having jurisdiction.

3.02.2 Protect structures, utilities, sidewalks, pavements, and other facilities from damage caused by settlement, lateral movement, undermining, washout and other hazards created by earthwork operations.

3.02.3 Protect excavations by shoring, bracing, sheet piling, or other methods, as required to prevent cave ins or loose dirt from falling into excavations.

3.02.4 Notify Soils Engineer of unexpected sub surface conditions and discontinue work in area until notification to resume work.

3.02.5 Protect bottom of excavations and soils around and beneath foundations from frost.

3.02.6 Grade around excavation to prevent surface water runoff into excavated area.

3.02.7 Repair damage.

3.03 PROTECTION OF EXISTING STRUCTURES

3.03.1 Perform earthwork requirements using appropriate methods and equipment as necessary to avoid damaging existing improvements and structures on adjacent properties including city streets.

3.03.2 Heavy construction equipment should not be operated within 10 to 15 feet of any existing building.

3.04 REFERENCES AND ELEVATIONS

3.04.1 Establish and preserve a suitable number of accurate reference monuments on the site.

3.04.2 Complete earthwork so that groundline elevations, building elevations, and paving surfaces and elevations are achieved as intended. Allow for granular fill, slabs, topsoil, etc, as necessary.

3.04.3 Intent. The intent of the requirements as they relate to surface elevations outside of buildings is that water will flow away from structures. The work shall be completed in a manner by which the intent is achieved.

3.0 5 SURFACE PREPARATION

3.05.1 All vegetation, loose, dumped debris, and any soils which are too soft to support construction equipment shall be removed.

3.05.2 Initial Inspection. All properly stripped areas where compacted fill is to be placed shall be inspected and approved by the Soils Engineer before commencing further work.

3.0 6 EXCESS WATER CONTROL

3.06.1 Unfavorable Weather.

- .1 Do not place, spread, or roll any fill material during unfavorable weather conditions.
- .2 As soon as practicable after unfavorable weather, the Contractor shall make every effort to return the site to a condition acceptable for continued operations as determined by the Soils Engineer.

3.06.2 Flooding. Provide berms or channels to prevent flooding on subgrade; promptly remove all water collecting in depressions.

3.06.3 Softened Subgrade. Where soil has been softened or eroded by flooding or placement during unfavorable weather, remove all damaged areas and recompact as specified for fill and compaction below.

3.06.4 Dewatering.

- .1 Provide and maintain at all times during construction, ample means and devices with which to promptly remove and dispose of all water from every source entering the excavations or other parts of the work.
- .2 Dewater by means which will ensure dry excavation and the preservation of the final lines and grades of bottoms of excavations.

3.0 7 EXCAVATION AND SITE PREPARATION

3.07.1 Remove pavement and sidewalks, topsoil material, roots, soft material, organic material, and unsuitable soils within all areas within which buildings or site improvements will be located, and areas to receive fill. Stockpile material in a location where it will not interfere with building or utility construction. Areas to be stripped shall first be scraped clean of all brush, vegetation, roots, and other material that will interfere with lawn maintenance or construction. The stored topsoil shall be used for finish grading. Trees or stumps designated for removal shall be hauled from the site and disposed of properly, in conformance with local regulations. Trees and stumps shall be removed in such a manner that no roots larger than 1 inch in diameter remain within areas where buildings or paving will be located, and no roots larger than 3 inches in diameter shall remain in any location.

3.07.2 If undesirable material is encountered during excavation, remove and replace material as directed by the Soils Engineer.

3.07.3 Slope back or excavate to building subgrade elevation as necessary. Shore, brace and sheet pile excavations as required to maintain them secure. Remove shoring as backfilling progresses, but only when banks of excavations are safe from caving or collapse. No excavation shall extend below an imaginary plane extending out and down from the edges of existing foundations at a slope of 3 horizontal to 1 vertical.

- .1 As a minimum, excavations should be performed in accordance with OSHA 29 CFR, Part 1926, Subpart P, "Excavations" and its appendices, and in accordance with any applicable local, state, and federal safety regulations. The contractor should be aware that slope height, slope inclination, and excavation depth should in no instance exceed those specified by these safety

regulations. Flatter slopes than those dictated by these regulations may be required depending upon the soil conditions encountered and other external factors.

3.07.4 Control grading around building, pitch grade to prevent water from entering excavated areas or damaging the structure. Maintain all pits and trenches where footings will be placed free from water at all times. Provide all pumping required to keep excavated spaces clear of water during construction. When springs or running water are encountered, notify the Architect, and provide free discharge of water by trenches, pumps and drain all water to appropriate point of disposal as directed.

3.07.5 Obtain Soils Engineer's inspection of excavation and approval that all undesirable material has been removed.

3.08 PROOF-ROLLING

3.08.1 After stripping, removal of undesirable materials, and excavation, the exposed subgrade in the building areas to a distance of at least 5 feet beyond the building perimeters and areas to receive fill shall be proof-rolled with a loaded tandem axle dump truck or similar piece of heavy rubber tired vehicle with an axle load greater than 9 tons. Proof-rolling shall be observed by the Soils Engineer. Soils that are observed to rut or deflect excessively (typically greater than 1-inch) under the moving load should be undercut and replaced with compacted fill.

3.09 SUBGRADE PREPARATION

3.09.1 After proof-rolling, the subgrade soils below slab-on-grades shall be scarified and compacted to at least 90% of the materials' modified proctor maximum dry density (ASTM D1557), to a depth of at least 12" below the surface.

3.10 FILLING

3.10.1 Perform filling as follows:

- .1 Remove all rocks, lumps, frozen ground, soft and wet material, vegetation, and other foreign material from areas within which fill is to be placed. Scarify and recompact existing ground surface as noted above. The fill should be placed in lifts not exceeding 9 inches in loose thickness. Compaction requirements for fills should be referenced to the ASTM D1557 (Modified Proctor) test method.
 - .a Structural fill: 90% of the maximum dry unit weight at a water content to within 0% to 5% of optimum water content.
 - .b Backfill for shallow utilities: 85% of the maximum dry unit weight at a water content to within -2% to +6% of optimum water content.
- .2 Compact fill and backfill using suitable mechanical tamping equipment to obtain specified density. Use mechanical hand tampers for filling and backfilling next to foundation walls. Before placing fills on subgrade, obtain approval from Soils Engineer or Architect. Obtain Soils Engineer's approval of methods and equipment used in fill placement.
- .3 Each lift shall be observed, tested and approved by the Soils Engineer prior to placement of subsequent lifts.

3.12 EXCAVATION FOR BUILDINGS AND STRUCTURES

3.12.1 Perform excavation for buildings and structures as follows:

- .1 Excavate to dimensions and elevations indicated, allowing additional space as required for construction operations and inspection of foundations. All foundations shall bear on native stiff to very stiff clay soils or newly placed engineered fill.

.2 Notify the Soils Engineer when excavations are ready for inspection before any concrete is placed and after reinforcing and formwork is erected. Place concrete footings after excavation has been inspected and approved and when weather conditions permit. When excavations for footings become soft and wet, remove all soft material and place extra depth with concrete at no additional cost to the Owner.

.3 Do not place footings or slabs on frozen earth. When freezing temperatures are anticipated, do not excavate to full depth indicated unless footings or slabs can be placed immediately after excavation is completed. Protect bottoms of excavations from freezing if placement of concrete is delayed. Do not place footings and floor slabs when temperature is below 40 degrees, unless approved by the Soils Engineer.

3.12 BACKFILLING

3.12.1 Requirements for backfilling shall be the same as for filling.

3.12.2 Do not backfill against any part of walls, piers, or columns until each part has reached its required design strength and has been inspected by the Soils Engineer. Do not backfill against foundation walls, curbs, footings and area ways until concrete forms have been removed and concrete finishing has been completed.

3.13 SUBGRADES

3.13.1 Floor slab subgrades should be composed of 8" of structural fill to provide uniform support for the floor slab.

3.13.2 Pavement subgrades should be composed of 12" of structural fill to provide uniformity and stability of the subgrade.

3.14 GRADING NEXT TO BUILDING

3.14.1 Unless otherwise indicated, evenly slope finish grade away from building walls at slopes not less than 3" in first 10 feet to provide proper drainage.

SECTION 3100

CONCRETE FORMWORK

1.0 GENERAL

1.01 WORK INCLUDED

1.01.1 The work included in this Section consists of formwork for cast-in-place concrete, with shoring, bracing and anchorage.

1.02 RELATED WORK SPECIFIED ELSEWHERE

Concrete Reinforcement	Section 3200
Cast-In-Place Concrete	Section 3300

1.03 SYSTEM DESCRIPTION

1.03.1 Contractor shall design, engineer, and construct formwork, shoring, and bracing to meet design and code requirements, so that resultant concrete conforms to required shapes, lines and dimensions.

1.04 QUALITY ASSURANCE

1.04.1 Contractor shall construct and erect concrete formwork in accordance with ACI 301 and 347.

1.05 REFERENCES

1.05.1 Reference standards include the following:

- .1 ACI 301 - Specifications for Structural Concrete for Buildings.
- .2 ACI 347 - Recommended Practice for Concrete Formwork.

2.0 PRODUCTS

2.01 FORM MATERIALS

2.01.1 All forms and shoring materials to be used shall be as determined and selected by the Contractor.

2.01.2 Void Forms: Biodegradable paper surface, treated for moisture resistance, structurally sufficient to support weight of plastic concrete and other superimposed loads.

2.02 FORM ACCESSORIES

2.02.1 Form release agent shall be material which will not stain concrete and will not absorb moisture.

2.02.2 Nails, spikes, lag bolts. Through bolts and Anchorages shall be sized as required of strength and character to maintain formwork in place while placing concrete.

3.0 EXECUTION

3.01 INSPECTION

3.01.1 Contractor shall verify lines, levels and measurements before proceeding with formwork.

3.02 PREPARATION

- 3.02.1 Earth forms may be used as a form for footings where appropriate, provided the soil is of sufficient strength and property to hold the trench line.
- 3.02.2 Hand trim sides and bottoms of earth forms; remove loose dirt prior to placing concrete.
- 3.02.3 Minimize form joints. Symmetrically align joints and make watertight to prevent leakage of mortar.
- 3.02.4 Arrange and assemble formwork to permit dismantling, so that concrete is not damaged during its removal.
- 3.02.5 Arrange forms to allow stripping without removal of principal shores, where required to remain in place.

3.03 ERECTION

- 3.03.1 Provide bracing to ensure stability of formwork. Strengthen formwork liable to be overstressed by construction loads.
- 3.03.2 Construct formwork to maintain tolerances in accord with ACI 301.

3.04 APPLICATION OF FORM RELEASE AGENT

- 3.04.1 Apply form release agent on formwork in accordance with manufacturer's instructions. Apply prior to placing reinforcing steel, anchoring devices, and embedded items.

3.05 INSERTS, EMBEDDED ITEMS, AND OPENINGS

- 3.05.1 Provide formed openings where required for work embedded in or passing through concrete.
- 3.05.2 Coordinate work of other sections in forming and setting openings, slots, chases, sleeves, bolts, anchors, and other inserts.
- 3.05.3 Install accessories in accordance with manufacturer's instructions, level and plumb. Take care to insure that items are not displaced during placement of the concrete.

3.06 FORM REMOVAL

- 3.06.1 Do not remove forms, shoring and bracing until concrete has sufficient strength to support its own weight, and construction and design loads which may be imposed upon it.
- 3.06.2 Remove formwork progressively so that no unbalanced loads are imposed upon the concrete structure.
- 3.06.3 Do not damage surfaces of concrete during removal of forms.

SECTION 3200

CONCRETE REINFORCEMENT

1.0 GENERAL

1.01 WORK INCLUDED

1.01.1 The work included in this Section consists of reinforcing steel bars, fibermesh, fabricated steel bar or rod mats for cast-in-place concrete.

1.02 RELATED WORK SPECIFIED ELSEWHERE

Concrete Formwork	Section 3100
Cast-In-Place Concrete	Section 3300

1.03 QUALITY ASSURANCE

1.03.1 Contractor shall perform concrete reinforcement work in accordance with the CRSI Manual of Standard Practice and CRSI Documents 63 and 65.

1.03.2 Work shall be in conformance to ACI 301 AND 315.

1.04 REFERENCES

1.04.1 Reference standards include the following:

ACI

- .1 ACI 301 - Specifications for Structural Concrete for buildings.
- .2 ACI 315 - Details and Detailing of Concrete Reinforcement.
- .3 ACI 318 - Building Code Requirements for Structural Concrete.

ASTM International

1. ASTM A185/A184M - Standard Specification for Welded Steel Wire Fabric for Concrete.
2. ASTM A496 - Standard Specification for Deformed Steel Wire for Concrete Reinforcement.
3. ASTM A615 - Standard Specification for Deformed and Plain Carbon-Steel Bars for Concrete Reinforcement.

CONCRETE REINFORCING STEEL INSTITUTE

- .1 CRSI - Manual of Standard Practice.
- .2 CRSI - Placing Reinforcing Bars.
- .3 CRSI 63 - Recommended Practice for Placing Reinforcing Bars.
- .4 CRSI 65 - Recommended Practice for Placing Bar Supports, Specifications and Nomenclature.

AMERICAN WELDING SOCIETY

- .1 D1.4 - Structural Welding Code - Reinforcing Steel.

1.05 SHOP DRAWINGS

1.05.1 Shop drawings shall comply with the General Conditions and General Requirements. Indicate detailing fabricating, bending and placing concrete reinforcement. Comply with ACI 315 "Manual of Standard Practice for Detailing Reinforced Concrete Structures" showing bar schedules, stirrup spacing, bent bar diagrams, and arrangement drawings shall be prepared by the Contractor in accordance with ACI 315, and submitted in accordance of concrete reinforcement. Include special reinforcing required for openings through concrete structures.

1.06 CERTIFICATES

1.06.1 Upon request, submit mill test certificates of supplied concrete reinforcing, indicating physical and chemical analysis.

1.07 QUALITY ASSURANCE

1.07.1 Codes and Standards: Comply with the provisions of the following codes, specifications, and standards, except where more stringent requirements are shown or specified:

- .1 2018 International Building Code
- .2 American Concrete Institute (ACI) 301, "Specifications for Structural Concrete for Buildings."
- .3 ACI 318, "Building Code Requirements for Structural Concrete."
- .4 Concrete Reinforcing Steel Institute (CRSI) "Manual of Standard Practice."

1.07.2 The Owner will employ and pay for the services of a "Special Inspector" as required by Section 1704 and Table 1705.3 and Table 1705.6 of the 2018 International Building Code and as indicated on the drawings. In general, the Special Inspector shall provide periodic inspection to observe the work and insure its conformance with the plans and specifications. Specific services shall include, but not be limited to inspection of reinforcement.

1.07.3 The Contractor shall notify the Special Inspector at least 48 hours prior to requirement of inspection. The contractor shall cooperate with the special inspector and shall not proceed with work until all special inspections have been successfully completed. The Special Inspector will furnish inspection reports to the owner and copy the architect, engineer, and contractor.

Materials and installed work may require testing and retesting at any time during progress of Work. Tests, including retesting of rejected materials for installed Work, shall be done at the Contractor's expense.

1.08 COORDINATION

1.08.1 Coordinate with placement of formwork, formed openings and other Work.

2.0 PRODUCTS

2.01 MATERIALS

2.01.1 Reinforcing steel shall be ASTM A615, 60 ksi yield grade billet-steel deformed bars, with uncoated finish.

- .1 Comply with ASTM A706, Grade 60 where welding of reinforcement is required. Epoxy coated in accordance with ASTM A775, where required.
- .2 Welded Wire Fabric: ASTM A185, flat sheet type welded steel wire fabric.
- .3 Supports for Reinforcement: Bolsters, chairs, spacers, and other devices for spacing, supporting, and fastening reinforcing bars and welded wire fabric in place. Use wire bar-type supports complying with CRSI specifications.
- .4 For slabs-on-grade, use supports with sand plates or horizontal runners where base material will not support chair legs.

2.02 ACCESSORY MATERIALS

2.02.1 Tie wire shall be minimum 16 gauge annealed type.

2.02.2 Chairs, Bolsters, Bar Supports, Spacers: Sized and shaped for strength and support of reinforcement during concrete placement conditions including load bearing pad on bottom to prevent vapor retarder puncture.

2.03 FABRICATION

2.03.1 Fabricate concrete reinforcement in accordance with CRSI, "Manual of Practice", ACI 318, "Building Code Requirements for Structural Concrete." Weld reinforcement in accordance with AWS D1.4.

3.0 EXECUTION

3.01 INSTALLATION

3.01.1 Before placing concrete, clean reinforcement of foreign particles or coatings.

3.01.2 Place, support, and secure reinforcement against displacement. Do not deviate from alignment or measurement. All reinforcing shall be set in place, tied and supported on bolsters or chairs prior to placement of concrete. "Wet-set" of reinforcing shall not be permitted.

3.01.3 Do not displace or damage vapor barrier as may be required by Section 3300. Repair damages before placing concrete.

3.01.4 Locate and support reinforcing by metal chairs, runners, bolsters, spacers, and hangers, as approved by Architect. Place reinforcement to maintain minimum coverages as indicated for concrete protection. Arrange, space, and securely tie bars and bar supports to hold reinforcement in position during concrete placement operations. Set wire ties so ends are directed into concrete, not toward exposed concrete surfaces.

SECTION 3300

CAST-IN-PLACE CONCRETE

1.0 GENERAL

1.01 WORK INCLUDED

1.01.1 Work included in this section consists of cast-in-place concrete for footings, foundations, floors and slabs on fill, curbs, walks, and paving.

1.02 RELATED WORK SPECIFIED ELSEWHERE

Concrete Formwork	Section 3100
Concrete Reinforcement	Section 3200
Concrete Finishin	Section 3350

1.03 QUALITY ASSURANCE

1.03.1 Contractor shall perform work in accordance with ACI 301.

1.03.2 Materials shall be obtained from the same source throughout the work.

1.03.3 Concrete for footings and walls shall be consolidated during placement with concrete vibrator in accordance with ACI 301.

1.03.4 Concrete for floor slabs and paving shall be consolidated during placement with vibrating screed or other means in accordance with ACI 301.

1.04 TESTS

1.04.1 Testing and analysis of concrete shall be performed in accordance with Section 1400.

1.04.2 All sampling and testing shall be performed by an independent materials testing company, which is not affiliated or associated with the General Contractor or the concrete supplier in any way. Sampling and testing shall be as follows:

- .1 Three concrete test cylinders and one air content test shall be taken for every 25 or less cubic yards of each concrete class placed each day plus additional compressive and air tests shall be made for each 50 cubic yards more than the first 25 cubic yards. Test one cylinder at 7 days, and two cylinders at 28 days.
- .2 One additional test cylinder shall be taken during cold weather and cured on site under the same conditions as concrete from which the sample was taken.
- .3 One slump test shall be taken for each truckload of concrete.

1.04.3 Test results shall be reported in writing to Architect, concrete manufacturer, and Contractor within 48 hours of testing. Reports of compressive-strength tests shall contain Project identification name and number, date of concrete placement, name of concrete testing and inspecting agency, location of concrete batch in Work, design compressive strength at 28 days, concrete mix proportions and materials, compressive breaking strength, and type of break for both 7-and 28-day tests.

1.05 REFERENCES

1.05.1 Reference standards include the following:

- .1 ACI 301 - Specifications for Structural Concrete for Buildings

- .2 ASTM C33 - Concrete Aggregates
- .3 ASTM C94 - Ready-Mixed Concrete
- .4 ASTM C150 - Portland Cement
- .5 ASTM C260 - Air-Entraining Admixtures for Concrete
- .6 ASTM C494 - Chemical Admixtures for Concrete

1.06 SUBMITTALS

1.06.1 Submit concrete mix design to the Architect as shop drawings, in accordance with the General Conditions and General Requirements for the following items:

- .1 Source of aggregate
- .2 Aggregate gradation
- .3 Pounds of aggregate per cubic yard
- .4 Pounds of water per pound of cement
- .5 Slump in inches
- .6 Percent of air content
- .7 Type and quantity of admixtures
- .8 Compressive strength

2.0 PRODUCTS

2.01 CONCRETE MATERIALS

2.01.1 Concrete ingredients shall be as follows:

- .1 Cement shall be ASTM C150, normal, Type I, Portland.
- .2 Aggregates shall be sand and gravel, except for exterior exposed surfaces, for which aggregate shall be limestone. For exterior exposed surfaces, do not use fine or coarse aggregates containing spalling causing deleterious substances.
- .3 Water shall be clean and not detrimental to the concrete.

2.02 ADMIXTURES

2.02.1 Air entrainment shall be in accordance with ASTM C260, and shall be of the percentages as indicated on the drawings.

2.02.2 Fly ash shall not be permitted in the concrete mix.

2.03 CONCRETE MIX

2.03.1 Concrete shall be mixed and delivered in accordance with ASTM C94.

2.03.2 Provide concrete of the strength and characteristics as listed on the structural drawings.

2.03.3 Use accelerating admixtures in cold weather only when approved by the Architect. Use of admixtures will not relax cold weather placement requirements, or required strength of concrete.

2.03.4 Use set retarding admixtures during hot weather only when approved by the Architect.

2.03.5 Slump shall be no greater than 5 inches.

2.03.6 Admixtures shall not contain calcium chloride.

3.0 EXECUTION

3.01 INSPECTION

3.01.1 Contractor shall verify that all anchors, seats, plates, reinforcement, and other items to be embedded into the concrete are accurately placed, held securely, and will not cause hardship in placing of the concrete.

3.02 PREPARATION

3.02.1 Prepare previously placed concrete by cleaning with steel brush and applying bonding agent. Apply bonding agent in accordance with manufacturer's instructions.

3.03 PLACING CONCRETE

3.03.1 Notify the Architect a minimum of 24 hours prior to commencement of placing of concrete.

3.03.2 Placement of concrete during hot weather, and cold weather shall be in accordance with ACI 301.

3.03.3 Insure that reinforcement, inserts, embedded items, and formed joints are not disturbed during placement of the concrete.

3.03.4 Maintain concrete cover around reinforcing at 3 inches at footings and foundations, and 1 inch at slabs.

3.03.5 Concrete for footings and walls shall be consolidated during placement with a mechanical concrete vibrator in accordance with ACI 301. Concrete for floor slabs and paving shall be consolidated during placement with vibrating screed or other means in accordance with ACI 301.

3.03.6 Saw cut control joints in accordance with layout drawings as approved by the Architect, an optimum time after finishing, when the concrete is sufficiently hard to prevent dislodging of the aggregates, but before shrinkage begins. Cut joints to a depth of 1 inch at 4 inch slabs and 1 1/2" inch at 6 inch slabs, using a 1/8 inch thick blade. At structural slabs, joints shall be 1/3 slab thickness maximum.

3.03.7 Excessive honeycomb or embedded debris in concrete is not acceptable. Notify Architect upon discovery.

3.04 FINISHING

3.04.1 Interior concrete slabs shall be finished with a smooth steel troweled finish. Exterior concrete shall be finished with a light broomed or burlap finish.

3.05 PATCHING

3.05.1 Notify the Architect immediately upon removal of forms if imperfections are found in the concrete. Patch imperfections as required.

3.06 DEFECTIVE CONCRETE

3.06.1 Concrete which does not conform to the required levels, slope, details or elevations shall be repaired or replaced as directed by the Architect. In the case of concrete not properly placed, or which does not test to the compressive strength as specified and in accordance with ACI 301, concrete shall be removed and replaced.

3.07 FIELD QUALITY CONTROL

3.07.1 Field inspection and testing shall be performed in accordance with these specifications, and as indicated in Section 1400.

3.07.2 Maintain records of placed concrete, recording date, location of pour, quantity, air temperature, and test samples taken.

3.08 PROTECTION AND CURING

3.08.1 Immediately after placement of concrete, protect from premature drying, excessively hot or cold temperatures, and mechanical injury. All concrete slabs and curbs shall be cured immediately after final finishing operation by the application of a curing compound in accordance with ASTM C-309.

3.09 CONCRETE FINISHING (HARDENER, SEALER, DUSTPROOFING)

3.03.1 Apply concrete finishing compound to entire warehouse floor as specified in Section 3350 – Concrete Finishing.

SECTION 3550

POLISHED CONCRETE FINISH

1.01 SUMMARY

A. Section Includes: This Section specifies [Dyed and] polished concrete.

B. Related Sections:

1. Section [03 01 30 Maintenance of Cast-in-Place Concrete].
2. Section [03 30 00 Cast-in-Place Concrete].
3. Section [07 92 00 Joint Sealants].

1.02 REFERENCES

A. American Concrete Institute (ACI):

1. ACI 302.1R Guide for Concrete Floor and Slab Construction.

B. ASTM International:

1. ASTM C309 Standard Specification for Liquid Membrane-Forming Compounds for Curing Concrete.
2. ASTM C171 Standard Specification for Sheet Materials for Curing Concrete.
3. ASTM C779 Standard Test Method for Abrasion Resistance of Horizontal Concrete Surfaces.
4. ASTM D523 Standard Test Method for Specular Gloss

1.03 SYSTEM DESCRIPTION

A. Performance Requirements: Provide polished flooring that has been selected, manufactured and installed to achieve the following:

1. ASTM C779 Method A- standard test method for abrasion resistance of horizontal concrete surfaces.
2. Reflectivity: ASTM D523, Specular gloss in accordance with architect's required gloss unit (GU) reading
3. ANSI B101.1- Test method for measuring wet SCOF of common hard surface floor materials.

B. Design Requirements:

1. Hardened Concrete Properties:
 - a. Minimum Concrete Compressive Strength: 4000 psi (24 MPa).
 - b. Normal Weight Concrete: No lightweight aggregate or deleterious materials.
 - i. Ensure all aggregates used are polishable.
 - c. Non-air entrained.
2. Placement Properties:
 - a. Natural concrete slump of 4 1/2 inches - 5 inches (114 - 127 mm). Admixtures may be used.
 - b. Any admixtures, plasticizers, slag, fly ash or anything taking the place of Portland-based cement shall not exceed 20%. * a straight cement mix is recommended
 - c. Flatness Requirements: Overall FF 50, Local FF 35.
 - d. Levelness Requirements: Overall FL 30, Local FL 20.
 - e. Hard-Steel Troweled (3 passes) Concrete: No burn marks. Finish to ACI 302.1R, Class 5 floor.
 - f. When placing edges use a 3' metal or wooden 2x 4 screed and run parallel with form or edge after initial screed and before floating.
 - g. Hand floating shall be parallel to edge and done in 2' increments to avoid lifting or depressing edges. Do not reach out beyond 2' of edge with hand tools or float in a fan direction pulling excessive mud to the forms.
3. Curing Options:
 - a. Membrane forming curing compounds (polyethylene film not recommended.)
 - b. Damp Curing: Seven day cure.
4. Slab Protection Immediately Following Placement (see also section 3.6):
 - a. Silicone chalks should NOT be used if at all possible. The RED and yellow chalks are PERMANENT DYES. RED Chalk, black markers, wax pencils should NOT be used for framing. White or Blue chalks are OK. Do not over mark for the framing. Do NOT use silicone sprays to "Hold" the lines. The sprays repel the stain and leave harsh, permanent scars on the floor.

b. Do not use , Tape, Glue, Solvents, Pine-Sol, Varnish, Non Breathing Plastics, Liquid Nail, Silicone, Plastics, Nails, Plumbers Glue, Foam Insulation, Bond Release Agents, Flux, Oils, Grease, Polyurethane, Paint, Markers (framers often write dimensions of doorways in marker on the slab. Ask them to make that note on the wood framing the doorway), Grease Sticks, Spray Paints, Crayons, Muriatic Acid, and other chemicals both before and after staining.

c. It is important that wood, sheet goods, insulation boards, plywood, press board, drywall, sections of framing and the like not lay on the slab for extended periods of time. They can transfer resins and tannins into the slab. This will alter the moisture content in the slab which leaves a pattern in the finished floor. Cardboard should be placed between the slab and the stacked material to minimize any unwanted transfers. Also Food, Beverages, Oil, Glass, Metal, Paint, Caulk, or Primers.

1.04 ACTION SUBMITTALS

A. General: Submit listed action submittals in accordance with Contract Conditions.

B. Product Data: Submit product data, including manufacturer's spec data product sheet, for specified products.

1. Material Safety Data Sheets (MSDS).
2. Preparation and concrete grinding procedures.
3. Colored Concrete Surface, Dye Selection Guides.

1.05 INFORMATION SUBMITTALS

A. Quality Assurance:

1. Test Reports: Certified test reports showing compliance with specified performance characteristics and physical properties as cited in 1.03 Performance Requirements.

2. Certificates:

a. Product certificates signed by manufacturer certifying materials comply with specified performance characteristics and criteria and physical requirements.

3. Manufacturer's Instructions: Manufacturer's installation instructions.

1.06 CLOSEOUT SUBMITTALS

A. Warranty: Submit warranty documents specified.

B. Operation and Maintenance Data: Submit operation and maintenance data for installed products.

1. Include:

a. Manufacturer's instructions on maintenance renewal of applied treatments.

b. Protocols and product specifications for joint filing, crack repair and/or surface repair.

1.07 QUALITY ASSURANCE

A. Qualifications:

1. Installer experienced in performing work of this section who has specialized in installation of work similar to that required for this project.

2. Installer trained and holding current certification in system to be applied (if available).

B. Mock-Ups:

1. Construct mock-ups in accordance with Section 1400 - Quality Control.

2. Mock-Up Size: 100 ft² (9.3 m²) sample panel at jobsite at location as directed under conditions similar to those which will exist during actual placement.

3. Mock-up will be used to judge workmanship, concrete substrate preparation, operation of equipment, material application, color selection and shine. Perform ASTM D523 Standard Test Method as cited in Section 2.02 Finishes and provide printed results to architect prior to commencement of work.

4. Allow 24 hours for inspection of mock-up before proceeding with work.

5. When accepted, mock-up will demonstrate minimum standard of quality required for this work.

Approved mockup may remain as part of finished work.

C. Preinstallation Meetings: Conduct a preinstallation meeting to verify project requirements, manufacturer's installation instructions and manufacturer's warranty requirements. Comply with Section 1200 - Project Meetings.

Review the following:

1. Environmental requirements.
2. Scheduling and phasing of work.
3. Coordinating with other work and personnel.
4. Protection of adjacent surfaces.
5. Surface preparation.
6. Repair of defects and defective work prior to installation.

7. Cleaning.
 8. Installation of polished floor finishes.
 9. Application of liquid hardener, densifier.
 10. Protection of finished surfaces after installation.
- 1.08 DELIVERY, STORAGE & HANDLING
- A. General: Comply with [01 61 00 - Common Product Requirements] [_____].
 - B. Ordering: Comply with manufacturer's ordering instructions and lead time requirements to avoid construction delays.
 - C. Delivery: Deliver materials in manufacturer's original packaging with identification labels and seals intact.
 - D. Storage and Protection:
 1. Store materials protected from exposure to harmful weather conditions and at temperature conditions recommended by manufacturer.
 2. Protect concrete slab.
 3. Protect from petroleum stains during construction.
 4. Diaper hydraulic power equipment.
 5. Restrict vehicular parking.
 6. Restrict use of pipe cutting machinery.
 7. Restrict placement of reinforcing steel on slab.
 8. Restrict use of acids or acidic detergents on slab.
 - E. Waste Management and Disposal:
 1. Separate waste materials for [Reuse] [And] [Recycling] [_____] in accordance with [Section 01 74 19 - Construction Waste Management and Disposal] [_____].
 2. Remove from site and dispose of packaging materials at appropriate recycling facilities.
- 1.09 PROJECT AMBIENT CONDITIONS
- A. Installation Location: Comply with manufacturer's written recommendations.
- 1.10 WARRANTY
- A. Project Warranty: Refer to Contract Conditions for project warranty provisions.
 - B. Manufacturer's Warranty: Submit, for Owner's acceptance, manufacturer's standard warranty document executed by authorized company official. Manufacturer's warranty is in addition to, and does not limit, other rights Owner may have under Contract Documents.
 - C. Warranty: Commencing on date of acceptance by [Owner] [Architect] [Consultant] [_____].
- 1.11 MAINTENANCE
- A. Comply with manufacturer's written instructions to maintain installed product.
- 1.12 EXTRA MATERIALS
- A. General Contractor to provide maintenance materials in accordance with Section [01 78 00 - Closeout Submittals] [_____].
- PART 2- PRODUCTS
- 2.01 MANUFACTURERS
- A. Ensure that manufacturer has a minimum of 5 years experience in manufacturing components similar to or exceeding the requirements of this project.
- 2.02 POLISHED CONCRETE FINISHING PRODUCTS
- A. Products/Systems:
 1. Hardener, Sealer, Densifier: Water based, odorless liquid, VOC compliant, environmentally safe chemical hardening solution leaving no surface film. Silicate or amorphous silica designed specifically to be used in conjunction with concrete polishing. No silicate hardener will be accepted.
 2. Polyurea Joint and Crack Filler: Semi-rigid, 2-component, self-leveling, 100% solids, rapid curing, control joint and crack filler with Shore A 80 or higher hardness.
 3. Spall Repair: Polymer modified cementitious material compatible with concrete polishing process designed to repair surface defects in concrete.
 4. Oil Repellent Sealer: Penetrating concrete sealer designed specifically to be used in conjunction with polished concrete.
 5. Concrete Dyes: Fast-drying dye, packaged in premeasured units ready for mixing with water or VOC exempt solvent; formulated for application to polished cementitious surfaces with UV stabilizers designed to help protect colorant from fading.
 6. Cleaning Solution: Mild, highly concentrated liquid concrete cleaner and conditioner; biodegradable, and environmentally safe. Cleaner must be pH neutral.

B. Finish: To be tested in accordance with ASTM D523 test method. Provide printed results to Architect, General Contractor, and Owner within 24 hours of completion. A minimum of 10 samples must be taken from each section of project to obtain an accurate average. Minimum will be no less than 80% of specified finish for any single test and no less than 90% as an average. [Matte Finish, 15 GU @ 60°], [Satin Finish, 30 GU @ 60°], [Semi-gloss, 45 GU @ 60°], [High gloss, 60 GU @ 60°] [_____].

C. Color: [_____].

D. Aggregate Exposure: [Paste finish: No aggregate exposed (less than 1/16")], [Minimal exposure: Average of 1/16"-

1/8" aggregate to be exposed and all paste removed from surface], [Medium exposure: Average of 1/4" – 3/8" aggregate to be exposed], [Heavy exposure: 1/2"- 3/4" aggregate to be exposed] [_____]. (Moderate exposure floors have an average of 1/4"-3/8" exposed, but will likely have substantial inconsistencies in exposure throughout and should not be specified if consistency is key!!!)

PART 3- EXECUTION

3.01 EXAMINATION

A. Site Verification of Conditions:

1. Verify that concrete substrate conditions, which have been previously installed under other sections or contracts, are acceptable for product installation in accordance with manufacturer's instructions prior to installation of concrete finishing materials.

2. Verify Concrete Slab Performance Requirements:

a. Verify concrete is cured to 28 day 4000 psi (24 MPa) strength.

b. Verify concrete surfaces received a hard steel-trowel finish (3 passes) during placement.

3.02 PREPARATION

A. Remove previously installed flooring using self-propelled flooring removal equipment only. Use of chipping guns, rotor hammers, or other equipment not specifically designed for removal of sheet flooring is strictly prohibited as it can damage underlying concrete.

B. Ensure surfaces are clean and free of dirt and other foreign matter harmful to performance of concrete finishing materials.

C. Examine surface to determine soundness for concrete for polishing.

D. Fill surface defects with acceptable cement based material compatible with polishing process.

E. Fill large cracks (greater than 1/16") with polyurea joint and crack filler flush with concrete surface.

F. General Contractor to remove surface contamination.

3.03 INSTALLATION

A. Sequence of Polishing:

1. Perform grinding and polishing [before partition studs are erected.] [after partition studs are erected, but before gypsum board is installed.] [after gypsum board and paint, but before casework and base are installed.]

B. Floor Surface Polishing and Treatment:

1. Provide polished concrete floor treatment in entirety of slab indicated by drawings. Provide consistent finish in all contiguous areas.

2. Apply floor finish prior to installation of fixtures and accessories.

3. Apply patching compound and crack filler flush with concrete surface where necessary.

4. Diamond polish concrete floor surfaces with planetary grinding machine with a minimum head pressure of 600 lbs (3-4 headed machine). Sequence with coarse to fine grit.

a. Comply with manufacturer's recommended polishing grits for each sequence to achieve desired finish level. Level of sheen shall meet specified gloss unit measurements.

b. Expose aggregate in concrete surface as determined by approved mock-up.

c. All concrete surfaces shall be as uniform in appearance as possible with no visible scratches anywhere in surface.

5. Grind and polish edges to a maximum of 1/8" of walls to match field area of floor.

6. Edge into corners with a maximum size of 5" diameter grinding & polishing discs.

7. Apply silicate densifier/hardener per manufacturer's specifications

8. Remove defects and re-polish defective areas.

9. Finish edges of floor finish adjoining other materials in a clean and sharp manner

C. Concrete Sealer:

1. No topical sealer allowed.
2. The appearance of any streaking or swirling from the use of topical sealing products will not be accepted. Identification of such issues will require the surface be ground off and re-polished.

D. Dyed and Polished Concrete (option):

1. Locate demarcation line between dyed surfaces and other finishes.
2. Apply dye per manufacturer's specifications.

E. Joint Fill:

1. Apply polyurea joint filler to saw cut contraction joints only. Product not to be used on tooled, expansion, keyed, or isolation joints. Refer to section [07 92 00 Joint Sealants] for these joints.
2. Slightly overfill joints to create a crown and allow the material to cure for 15-20 minutes or until dry to the touch.
3. Shave excess joint fill off flush with the top of the slab with a razor blade to create a seamless finish.

3.04 ADJUSTMENTS

- A. Polish to higher gloss those areas not meeting specified gloss levels per mock-up.
- B. Fill joints flush to surface.

3.05 FINAL CLEANING

- A. Do cleanup in accordance with Section [01 74 00 - Cleaning and Waste Management] [_____].

3.06 PROTECTION

- A. It is important that wood, sheet goods, insulation boards, plywood, press board, drywall, sections of framing and the like not lay on the slab for extended periods of time. They can transfer resins and tannins into the slab. This will alter the moisture content in the slab which leaves a pattern in the finished floor. Cardboard should be placed between the slab and the stacked material to minimize any unwanted transfers. Also Food, Beverages, Oil, Glass, Metal, Paint, Caulk, or Primers
- B. It is extremely important that you do not tape directly to the floor! Duct Tape, Masking Tape, Packaging Tape, Strap Tape, Blue Tape, Green Tape, and Electrical Tape there are NO exceptions. The tape alters the natural curing process and transfers chemicals to and from the slab. Tape, Plastics and other Adhesives can contribute to Plasticizer Migration. This WILL SHOW in the finished product.

SECTION 6100

ROUGH CARPENTRY

1.0 GENERAL

1.01 RELATED WORK SPECIFIED ELSEWHERE

Treated Wood

Section 6300

1.02 STORAGE

1.02.1 Store lumber and rough carpentry materials on bunks or skids, level, and at least 6 inches above the ground and protect materials from weather with waterproof covers. Allow ventilation to avoid entrapment of moisture.

1.03 INFORMATIONAL SUBMITTALS

1.04.1 For dimensional lumber specified to comply with minimum allowable unit stresses, indicate species and grade selected for each use and design values approved by the ALSC Board of Review.

2.0 MATERIALS

2.01 LUMBER

2.01.1 Lumber shall be seasoned, kiln dried, S4S and graded in accordance with the Western Wood Products Association Rules Book, latest edition, and shall bear a grade stamp by the WWPA, or graded in accordance with the Southern Pine Inspection Bureau Standard Grading Rules for Southern Pine Lumber, latest edition, and shall bear a grade stamp by the Southern Pine Inspection Bureau. Provide lumber of the species and fiber stresses as follows:

- .1 Lumber for non-bearing stud walls, plates and miscellaneous:
Stud Grade, Fb = 575, Fc = 425, E = 1,200,000.
- .2 Lumber for bearing walls and plates: refer to Timberlyne structural drawings.
- .3 Lumber for I-Joists, headers and rafters: refer to Timberlyne structural drawings.
- .4 Heavy Timber, refer to Timberlyne structural drawings.

2.03 SILL PLATES

2.03.1 Lumber for sill plates shall be Borate or CCA treated Southern Pine #2.

2.05 SILL SEALER

2.05.1 Sill Sealer shall be 1 inch thick by 6 inches wide fiberglass and shall be installed between the foundation and sill plates continuously.

2.06 MISCELLANEOUS FRAMING HARDWARE AND FASTENERS

2.06.1 Provide framing anchors, joist hangers, nails, and all other miscellaneous connectors required, whether shown on the drawings or not, required to complete the rough and finish carpentry. Provide nails in sizes and spacings as indicated on the Timberlyne drawings, if not listed on drawings then in accordance with the 2018 International Building Code.

2.07 NAILS AND FASTENERS

2.07.1 All nails and fasteners shall be as indicated on the Timberlyne drawings in accordance with the 2018 International Building Code and in accordance with generally accepted industry standards.

3.0 EXECUTION

3.01 WOOD FRAMING

3.01.1 Erection of Wood Studs and Framing

- .1 Studs shall be 2x4 or 2x6 wood studs as indicated on drawings, for all interior walls and partitions. See plans for location of wall types. Erect studs with large dimension perpendicular to the wall, unless otherwise shown or noted.
- .2 Provide triple studs at corners and intersecting walls.
- .3 Double studs at openings in interior non-bearing partitions. Provide studs at jambs at openings in exterior walls and bearing walls as shown on structural drawings.
- .4 Frame above openings in non-bearing partitions with two 2 x 6's on edge, unless noted otherwise. Frame above openings in load bearing walls as shown on structural drawings.
- .5 Top Plate shall be doubled, overlapped at corners and intersecting walls, with end laps 4 feet minimum.
- .6 Sill plates at interior non-bearing walls shall be anchored to concrete floor with power driven fasteners. Use Hilti .145" diameter nail, 2 7/8" long, with 36 mm diameter steel washer. Other anchors may not be used unless noted otherwise on the drawings, or as approved by the Architect.
- .7 Sill plates shall be anchored to foundation walls with anchor bolts as specified elsewhere.
- .8 Headers shall bear on studs at each jamb. Headers shall be fastened together and set on edge. Provide sizes as indicated on the drawings, and provide specific bearing members as indicated on the drawings.
- .9 Stud Bridging/Fire Stopping. All studs which are in excess of ten feet in height shall be braced with solid blocking cut from stud material of same size as wall studs. Locate bridging as indicated on the drawings, and as required by code.
- .10 Do not splice structural members between supports unless otherwise indicated.

3.01.2 Erection of Wood Joists

- .1 Girders and beams which are 10 inches or less in depth shall be spiked together with 16d nails at 12 inches on center.
- .2 Space joists as indicated on the drawings.
- .3 Bearing. Joists and beams shall bear at least 3 inches on concrete or masonry, 1 1/2 inches on wood or metal.
- .4 Anchors and Ties. Joists flush with top of beams or girders and trimmers, headers and tail joists over 6 feet long shall be hung on metal stirrups or hangers. Lap and nail ends of other joists to form continuous ties between outside walls. Securely tie joists, beams or trimmers to the corresponding member on the opposite side of bearing.
- .5 Bridging. Brace joists with spans in excess of 8 feet with 1x3 diagonal wood bridging at intervals not to exceed 8 feet on center.

3.01.3 Erection of miscellaneous framing and blocking shall be as shown on the drawings or as required to secure finish materials to rough construction.

3.01.4 Anchor framing and blocking to concrete as indicated on the drawings with anchor bolts, concrete nails or powder driven fasteners as approved by the Architect. Anchor bolts shall be built into the concrete. Powder driven fasteners may be used to anchor interior partitions to the concrete slab.

3.01.5 Notching, when required shall not exceed the following:

Non-reinforced hole in studs	1/3 x depth
Sills and plates cut	Reinforce with 1/8 inch x 8 inch x 1 1/2 inch metal ties nailed with 16d nails.

3.01.6 Nailing. Number and spacing of nails and method of nailing of framing shall be in accordance with the Drawings, common industry standards and practices, the 2009 International Building Code, and as specified herein.

3.02 INSTALLATION OF FLOOR SHEATHING

3.02.1 Install floor sheathing with face grain across supports and ends on support centerlines. Space panels 1/16 inch at ends and panel edges, and nail to supports along panel edges and at field of panel as indicated on the structural drawings.

3.03 INSTALLATION OF TREATED LUMBER AND MISCELLANEOUS PLYWOOD

3.03.1 Install treated lumber for sills and other areas where required as specified for wood framing.

3.03.2 Install miscellaneous plywood to furring, blocking, or supports with nails spaced at 6 inches on center at panel edges and at 12 inches on center at field of panel, unless noted otherwise on the drawings.

SECTION 6200

FINISH CARPENTRY

1.0 GENERAL

1.01 SUBMITTALS

1.01.1 Submit shop drawings in accord with the General Conditions and General Requirements, including samples of actual materials.

1.02 PRODUCT DELIVERY, STORAGE AND HANDLING

1.02.1 Store finish carpentry materials indoors on level surface. Moldings, cabinets, and closet and storage shelving materials shall not be delivered until the building or storage area is enclosed and sufficiently dry so that materials will not be damaged by excessive moisture. Condition composition materials for interior applications to room temperature and humidity by unwrapping and standing separately on their long edges for at least 48 hours prior to application.

1.03 JOB CONDITIONS

1.03.1 Scheduling. Do not install finish carpentry materials until exterior doors and windows are in place and until gypsum wallboard joint treatment is thoroughly dry and the interior of the building is dried out. Do not install composition materials until the building humidity has stabilized.

2.0 PRODUCTS

2.01 SOFTWOOD MATERIALS

2.01.1 Softwood materials shall be kiln dried and graded in accordance with the 1988 Western Wood Products Association Rules Book and grade stamped by Western Wood Products Association, or graded in accordance with the 1988 Southern Pine Inspection Bureau Standard Grading Rules for Southern Pine Lumber and grade marked by the Southern Pine Inspection Bureau. Materials shall be as follows:

- .1 Solid wood for shelving cleats, hookstrips exposed blocking shall be No. 2 Idaho White Pine, or paint grade Birch, or Poplar.
- .2 Miscellaneous Solid Wood for blocking, furring, nailers, cabinet and counter framing, bases, and other similar applications which are concealed shall be Standard or Better, any species.

2.02 PLYWOOD MATERIALS

2.02.1 Softwood plywood shall meet the requirements of Product Standard PS-1 for softwood plywood, and shall bear the APA trademark of the American Plywood Association. Provide oak veneer plywood for beams and trim as indicated on the drawings.

2.03 COMPOSITION MATERIALS

2.03.1 Particleboard shall meet the requirements of Commercial Standard CS 236, Type 1-B-2, shall have a density of 43 pounds to 45 pounds per cubic foot, and shall be 3/4", unless otherwise noted or specified.

- .1 Particleboard for closet, storage, utility and linen shelving shall be as hereinafter specified under Fabrication. Thickness shall be 3/4" unless otherwise specified, and material shall have a molded front edge.

2.04 FASTENINGS AND ADHESIVES

2.04.1 Fasteners for wood furring shall be case hardened steel self tapping screws, power driven nails, or standard wire nails, suitable for attachment to wood studs, and shall be of sufficient length to penetrate face of wood studs a minimum of one and one half inch.

2.04.2 Nails for other finish carpentry materials shall be as follows:

Stock up to 1/2 inch thick	4d finishing or casing nails
Stock 1/2 to 3/4 inch thick	6d finishing or casing nails
Stock 3/4 to 1 inch thick	8d finishing or casing nails
Stock 1 to 1 1/4 inch thick	10d finishing or casing nails
Stock 1 1/4 to 1 1/2 inch thick	12d finishing or casing nails

2.04.3 Miscellaneous fastenings. Provide screws, toggle bolts, expansion bolts, and other miscellaneous fastenings to secure finish carpentry items in place.

2.04.4 Adhesives shall be as follows:

Plastic Laminate As recommended by laminate mfg.

2.05 FABRICATION

2.05.1 Closet, utility and storage shelving shall be made for opaque finish, shall conform to the design and details shown on the Drawings, and shall meet the requirements for Economy Grade Closet and Storage Shelving as defined in the Architectural Woodwork Institute Quality Standards, Section 600. Unless otherwise shown on the Drawings, closet and storage shelving shall be as follows:

Shelves	Particleboard, with rounded and filled front edge or plywood with solid wood front edge
Cleats	1 x 3 softwood

2.06 HARDWOOD MATERIALS

2.06.1 Wood for miscellaneous oak trim shall be Northern Red Oak, of the sizes and configuration as indicated on the drawings.

3.0 EXECUTION

3.01 INSTALLATION OF WOOD MOLDINGS AND TRIM

3.01.1 Set moldings and trim straight, plumb and level, in perfect alignment, and closely fitted together. Joints shall be tight and made in a manner to conceal shrinkage. Nail to bearings at 16 inch centers. Countersink nails slightly and putty.

3.02 INSTALLATION OF FABRICATED ITEMS

3.02.1 Closet and storage shelving shall be assembled and installed plumb and level. Cleats shall be securely fastened to walls with nails or screws. At closet shelves in excess of 3 feet length, provide support at 3 feet maximum spacing as indicated on the drawings.

3.03 FINISH OF WOOD MOLDINGS AND TRIM

3.03.1 Wood moldings and trim shall be stained and varnished as specified in Section 9800.

SECTION 6300

WOOD TREATMENT

1.01 GENERAL

1.01 RELATED WORK SPECIFIED ELSEWHERE

Rough Carpentry

Section 6100

1.02 ACCEPTABLE MANUFACTURERS

1.02.1 Acceptable manufacturers are those listed by the American Wood Preservers Institute in their current directory as suppliers of the pressure-treated wood products.

1.03 QUALITY MARK

1.03.1 AWPI Quality Mark. Each piece of lumber shall bear the American Wood Preservers Institute Quality Mark to indicate conformance with the AWPI Standard hereinafter specified. The information required by the American Wood Preservers Institute Standard must appear on the label.

1.04 DELIVERY, STORAGE AND HANDLING

1.04.1 Store pressure-treated lumber indoors, if possible, or on a raised platform under waterproof coverings.

2.0 PRODUCTS

2.01 LUMBER FOR PRESSURE TREATMENT

2.01.1 Rough carpentry material used in association with sill plates, or in direct contact with slabs-on-grade shall meet the requirements of miscellaneous framing and blocking materials as specified in Section 6100, Rough Carpentry.

2.02 PRESSURE TREATMENT

2.02.1 Pressure treat rough carpentry material for decay resistance with water-borne preservatives for ground contact use to meet the requirements of Standard AWPI LP-22, latest edition.

2.03 ONSITE TREATMENT

2.03.1 Cuts resulting from site fabrication shall be liberally coated with a concentrated solution of the preservative.

3.0 EXECUTION

3.01 SCHEDULE OF INSTALLATION

3.01.1 Install treated wood at all sill plates over concrete floor slabs, and at rough bucks installed at window and door openings in exterior walls. Installation of treated wood shall be as specified in Section 6100, Rough Carpentry.

SECTION 6650

SOLID POLYMER FABRICATIONS

1.0 GENERAL

1.01 RELATED WORK SPECIFIED ELSEWHERE

Rough Carpentry	Section 6100
Gypsum Drywall	Section 9250
Cabinets and Countertops	Section 6650

1.02 REFERENCES

1.02.1 Applicable standards shall be those as listed below:

- .1 American National Standards Institute (ANSI)
- .2 American Society for Testing Materials (ASTM)
- .3 National Electrical Manufacturers Association (NEMA)
- .4 Federal Specifications (FS).

1.03 SUBMITTALS

1.03.1 Submit shop drawings, indicating dimensions, component sizes, fabrication details, attachment provisions and coordination requirements with adjacent work.

1.03.2 Submit minimum 2" x 2" samples indicating full range of color and pattern variation. Approved samples will be retained as standards for the work.

1.03.3 Product data shall include product description, fabrication information and compliance with specified performance requirements.

1.03.4 Maintenance data. Submit manufacturer's care and maintenance data, including repair and cleaning instructions, at time of submittal of close out documents.

1.04 QUALITY ASSURANCE

1.04.1 Allowable tolerances. Variation in component sizes and location of openings shall not be greater than 1/8 inch.

1.05 DELIVERY, STORAGE AND HANDLING

1.05.1 Deliver no components to project site until areas are ready for installation of the materials. Store components indoors prior to installation.

1.05.2 Handle materials to prevent damage to finished surfaces. Provide protective coverings to prevent physical damage or staining following installation for duration of project.

1.06 WARRANTY

1.06.1 Provide manufacturer's 10 year warranty against defects in materials. Warranty shall provide material and labor to repair or replace defective materials. Damage caused by physical or chemical abuse or damage from excessive heat will not be warranted.

1.06.2 This Warranty applies to installed products which are maintained in accordance with the manufacturer's maintenance guidelines. Provide maintenance instructions to Owner as a part of close out documents.

2.0 MATERIALS

2.01 SOLID POLYMER FABRICATIONS - VANITY TOPS

2.01.1 Vanity tops at toilet rooms shall be "Stonecoat" solid surfacing material as manufactured by Roman Marble Products, Omaha, Nebraska. Vanity tops shall include an integral bowl, and shall have integral backsplash and field applied endsplash sections at all adjoining walls, and apron panel for front of vanity as detailed on the drawings. Solid polymer fabrications shall be cast, nonporous, filled polymer, not coated, laminated or of composite construction with through body colors meeting ANSI Z124.3 or ANSI Z124.6. Bowl type shall be "Wave Bowl". Superficial damage to a depth of 0.010" shall be repairable by sanding and polishing. Provide vanity tops of the configuration and sizes as indicated on the drawings. Color of vanity tops shall be as selected by the Architect.

2.01.3 Vanity tops shall be 3/4 inch thick, suitable for adhesive application to substrate. Provide radiused edges and other features as indicated on the drawings.

2.01.4 Adhesive shall be manufacturer's standard neoprene-based panel adhesive meeting ANSI A136.1-1967, UL listed (in accordance with technical bulletin CTDC 102).

2.01.5 Sealant shall be manufacturer's standard mildew-resistant FDA/UL recognized silicone sealant in color matching formulations (in accordance with technical bulletin 102, 107).

2.03 FABRICATION

2.03.1 Fabrication shall be performed by a certified Manufacturer's fabricator/installer. Fabricate components in shop to sizes and shapes indicated, in accordance with approved shop drawings and DuPont requirements.

2.03.2 Rout and finish component edges to a smooth, uniform finish. Rout all cutouts, then sand all edges smooth. Repair or reject defective or inaccurate work.

3.0 EXECUTION

3.01 INSTALLATION

3.01.1 Install components plumb and level, in accordance with approved shop drawings and product installation details.

3.01.2 Protect surfaces from damage until final acceptance by the Owner. Repair or replace damaged work that cannot be repaired to the Architect's satisfaction, and at no additional cost to the Owner.

SECTION 7190

VAPOR BARRIER

1.0 GENERAL

1.01 SHOP DRAWINGS

1.01.1 Submit shop drawings in accordance with the General Conditions and General Requirements.

1.02 PRODUCT DELIVERY, STORAGE AND HANDLING

1.02.1 Store vapor barrier to prevent tears and other damage, which would affect its integrity and performance.

2.0 PRODUCTS

2.01 VAPOR BARRIER MATERIALS – BELOW CONCRETE SLABS

2.01.1 Vapor shall be Visqueen Polyethylene Film manufactured by Visqueen Division of Ethyl Corporation. Vapor barrier beneath concrete floor slabs on grade shall be 15 mil thickness, Class A. Vapor barrier at wood stud walls shall be 4 mil thickness.

2.01.3 Pressure-sensitive tape shall be Zero Perm, 1-1/2 inch wide tape, manufactured by Alumiseal Corporation, and shall consist of aluminum foil 1.0 mils thick, laminated between two sheets of polyester film, with a vapor transmission of 0.015 perms or less and a permanent pressure-sensitive adhesive on one face.

2.01.4 Miscellaneous items, including mechanical fastenings and other accessories, shall meet the recommendations of the vapor barrier manufacturer.

3.0 EXECUTION

3.01 INSTALLATION OF VAPOR BARRIER ON GRADE BENEATH CONCRETE SLAB

3.01.1 Preparation. Level and tamp base.

3.01.2 Installation. Install vapor barrier over subgrade utilizing maximum sheet sizes to minimize joints. Exercise care to avoid punctures. No penetrations such as grade stakes or other construction method related penetrations shall be allowed through the vapor barrier except for mechanical piping as indicated on the drawings. Lap all joints 6 inches and seal with pressure sensitive tape. Use additional vapor barrier material to seal punctures, tears, and penetrations through the barrier.

3.01.2 At perimeter of building, where concrete floor slab intersects walls, turn up vapor barrier seal vapor barrier to walls with continuous bead of mastic, and seal top of vapor barrier to wall with tape.

3.01.2 Where piping penetrates through the vapor barrier, form a collar using additional vapor barrier material, and seal to the horizontal layer with tape.

3.02 INSTALLATION OF VAPOR BARRIER AT EXTERIOR WALLS

3.02.1 At all wood stud walls at perimeter of office area, install vapor barrier over face of studs and secure in place with staples. Vapor barrier shall be continuous to cover the inside face of thermal insulation, using maximum sheet size to minimize joints. Exercise care to avoid punctures. Lap all joints 6 inches over bearing members, and seal with pressure sensitive tape. Use pressure-sensitive tape with additional vapor barrier material to seal punctures, tears, and penetrations through the barrier.

SECTION 7210

BUILDING INSULATION

1.0 GENERAL

1.01 WORK OF THIS SECTION

1.01.1 The work of this section includes thermal insulation at wood stud walls

1.02 RELATED WORK SPECIFIED ELSEWHERE

Vapor Barrier	Section 7190
Nailbase Insulation Panels	Section 7221
Rigid Insulation	Section 7250

1.03 SUBMITTALS

1.03.1 Submit shop drawings in accord with the General Conditions and General Requirements.

1.04 PRODUCT DELIVERY, STORAGE, AND HANDLING

1.04.1 Store insulation materials to prevent from becoming wet, soiled, or covered with ice or snow.

2.0 PRODUCTS

2.01 INSULATION - GENERAL

2.01.1 All batt insulation products shall consist of glass fiber or mineral wool fibers and resinous binders formed into flexible blankets. Insulation products shall be by one of the following manufacturers:

CertainTeed Corporation	Johns-Manville Corp.
Owens-Corning Fiberglass	Rockwool Industries, Inc.
United States Gypsum	

2.02 UNFACED FRICTION FIT INSULATION

2.02.1 Unfaced batt insulation shall be flexible blankets of the thickness and insulating values as indicated on the drawings.

2.03 SOUND ATTENUATION BATTS

2.03.1 Sound attenuation batts shall consist of glass fiber or mineral wool fibers and resinous binders formed into flexible unfaced friction fit blankets, 3 1/2 inches or 5 1/2 inches thick, to fit full thickness within wall cavity.

2.04 ADHESIVES, MECHANICAL FASTENERS, AND ACCESSORIES

2.04.1 Adhesives, mechanical fasteners and accessories shall be as recommended by the insulation manufacturer.

2.04.2 Polyethylene vapor barrier for use over unfaced friction fit insulation at walls shall be as specified in Section 7190.

3.0 EXECUTION

3.01 GENERAL

3.01.1 Building insulation shall be installed such that a complete and continuous insulation envelope is formed at all wood framed walls and ceilings at the office area. Insulation shall be continuous through all sections of the building, with all wall cavities within floor framing spaces fully insulated with the type and thickness of insulation as indicated on the drawings.

3.02 INSTALLATION OF UNFACED BATT INSULATION

3.02.1 At walls, unfaced batt insulation shall be installed between supports with the edges of insulation fitting snugly between supports to insure continuity of the insulation envelope. At stud or joist spaces which are less than standard width, cut insulation to fit tightly between supports, and install completely in cavity to insure a complete insulation envelope.

3.02.2 At all openings in exterior walls, including windows, doors, sleeves and other openings, fill gap between rough opening and frame of windows, doors, sleeves and other openings completely with pieces of fiberglass batt insulation (chinking) in cavity to insure a complete insulation envelope. Install chinking loosely within cavities and avoid packing tightly.

3.02.3 Poly vapor barrier shall be installed as follows:

- .1 over the face of unfaced insulation at walls which will be covered with gypsum board, as specified in Section 7190 - Vapor Barrier.
- .2 over face of studs at exterior walls of office areas where insulated metal panel walls are installed.

3.03 INSTALLATION OF SOUND ATTENUATION BATTS

3.03.1 Sound attenuation batts shall be provided at all walls of rooms as indicated on the plans. Install sound attenuation batts full height and width of all cavities in such a manner to eliminate any voids at full length and width of the stud space in which they are scheduled to be installed. Provide 3 1/2 inch thick batts at all 2 x 4 walls, and 5 1/2 inch thick batts at all 2 x 6 walls.

SECTION 7221

NAILBASE INSULATION PANELS

PART 1 GENERAL

1.1 SECTION INCLUDES

- A. Section includes nailbase insulation panel system.

1.2 RELATED SECTIONS

- A. Section 6110 - Wood Framing: Structural deck sheathing.
- B. Section 6114 - Wood Blocking.
- C. Section 6150 - Wood Decking.
- D. Section 7260 - Vapor Retarders.

1.3 REFERENCES

- A. ASTM C 209 - Methods of Testing Insulating Board, Structural and Decorative.
- B. ASTM C 1289 - Specifications for Faced Rigid Cellular Polyisocyanurate Thermal Insulating Board.
- C. ASTM D 1621 - Test Methods for Compressive Properties of Rigid Cellular Plastics.
- D. ASTM D 2126 - Test Method for Response of Rigid Cellular Plastics to Thermal and Humid Aging.
- E. ASTM E 96 - Test Method for Water Vapor Transmission of Materials.
- F. CAN/ULC S770 - Standard Test Method for Determination of Long Term Thermal Resistance of Closed Cell Plastic Thermal Insulating.
- G. UL 1256 - Fire Test of Roof Deck Constructions.
- H. PS2-92 - Performance Standard for Wood-based Structural-use Panels.
- I. FM 4450 - Class I Insulated Steel Deck Roofs.
- J. FM 4470 - Class I Roof Covers (Foam Core Only).
- K. FM Class 1 approval for steel roof deck constructions, Class 1 Fire and I-60 and I-90 wind storm classifications

1.4 SYSTEM DESCRIPTION

- A. Physical properties (Foam Core):
 - 1. Compressive Strength: ASTM D 1621 and ASTM C 1289, Type V, 20 psi (138 kPa) minimum for Grade 2 or 25 psi (172 kPa) minimum for Grade 3.
 - 2. Dimensional Stability: ASTM D 2126, 2 percent linear change (7 days).
 - 3. Moisture Vapor Transmission: ASTM E 96, < 1 perm ((57.5ng/(Pasm²)).
 - 4. Water Absorption: ASTM C 209, < 1 percent by volume.
 - 5. Service Temperature: Minus 100 degrees to 250 degrees F (Minus 73 degrees C to 122 degrees C).
 - 6. Foam core flame spread index of 70 or less and smoke developed of 450 or less when tested in accordance with ASTM E 84.

- B. Foam Core R Values: Based on LTTR (Long Term Thermal Resistance) in accordance with ASTM C 1289.
- C. UL Assemblies: Insulated metal deck assemblies - UL 1256 (nos. 120, 123).
- D. UL Assemblies: Insulated metal deck assemblies - UL 1256 (nos. 120, 123) TGDY. R20624 Shingle Deck Accessory; H-Shield Nail Base roof insulation is classified for use with any Class A, B, or C asphalt glass mat or asphalt organic shingles, metal or tile roof coverings.
- E. FM Class 1 (Low Slope) approval for steel roof deck constructions, Class 1 Fire and I-60 and I-90 wind storm classifications.
- F. USGBC LEED requirements:
 - 1. OSB or plywood must be FSC certified. Manufacturer of vented nailbase to supply FSC Chain-of-Custody number.

1.5 SUBMITTALS

- A. Submit under provisions of Section 01300.
- B. Product Data: Manufacturer's data sheets on nailbase insulation panels and fasteners to be used, including:
 - 1. Preparation instructions and recommendations.
 - 2. Storage and handling requirements and recommendations.
 - 3. Installation methods.
- C. Verification Samples: For each finish product specified, two samples, representing actual product.
 - 1. Submit 6 by 6 inch (152 mm by 152 mm) samples of each board type required.
 - 2. Submit samples of each fastener type required.
- D. Manufacturer's Certificate: Certify nailbase insulation panels will conform to specified performance requirements.

1.6 QUALITY ASSURANCE

- A. Manufacturer Qualifications: Manufacturer shall be a company that regularly manufactures polyisocyanurate and fully assembled nailbase insulation panels in-house with no outside fabrication operations.

1.7 DELIVERY, STORAGE, AND HANDLING

- A. Store products in accordance with the manufacturer recommendations.
- B. Store product on a solid flat foundation and elevate a minimum of 4 inches above the finished surface.
- C. For on-site storage longer than two weeks, slit packaging on 4 sides to allow the product to breathe, and then completely covered with a breathable tarpaulin.
- D. Protect insulation from open flame and keep dry at all times.

1.8 PROJECT CONDITIONS

- A. Install only as much insulation as can be covered the same day by a completed roof covering material.

PART 2 PRODUCTS

2.1 MANUFACTURERS

- A. Acceptable Manufacturer: Sand Creek Post and Beam.

- B. Requests for substitutions will be considered in accordance with provisions of Section 01600.

2.2 PANEL CONSTRUCTION

- A. Panels shall consist of a top layer of APA/TECO rated Oriented Strand Board (OSB) core that is laminated, on-line, to a bottom layer of black fiber reinforced faced polyisocyanurate foam insulation.
 - 1. Polyisocyanurate foam insulation shall conform to ASTM C 1289, Type V.
 - 2. Compressive Strength: 20 pounds per square inch (138 kPa) Grade 2.
 - 3. Compressive Strength: 25 pounds per square inch (172 kPa) Grade 3.
 - 4. OSB Top layer substrate shall conform to PS2 and shall be as follows:
 - a. OSB:
 - 1) Type:
 - a) Standard sheathing grade.
 - b) FSC certified sheathing grade.
 - 2) Thickness:
 - a) 7/16 inch (11.1 mm).
 - b. Edge detail:
 - 1) Rabbeted.
 - 2) Non-rabbeted.

2.3 PANEL TYPES

- 1. 7/16" OSB with 7 1/4" rigid insulation. R-33.

2.4 PANEL FASTENERS

- A. Fasteners shall be FM Approved Hunter Panel SIP/WD Panel fasteners for wood deck application. Fasteners have a 3/16 inch (5 mm) shank, and are corrosion resistant with oversized heads. Length of fasteners shall be as recommended by Hunter Panels. Use of 2 inch (51 mm) round plates are not required. See the Hunter Panels application guide for instructions.
 - 1. Fasteners shall penetrate the purlin a minimum of 2 inch (25 mm) or otherwise specified on Timberlyne Drawings.

PART 3 EXECUTION

3.1 EXAMINATION

- A. Do not begin installation until substrates have been properly prepared.
- B. Verify deck, adjacent materials, and structural backing is dry and ready to receive insulation.
- C. Verify deck surface is flat, free of fins, protrusions and irregularities.
- D. If deck preparation is the responsibility of another installer, notify Architect of unsatisfactory preparation before proceeding.

3.2 PREPARATION

- A. Clean surfaces thoroughly prior to installation.
- B. Apply vapor barrier and or retarder, as specified by the Architect or required by the local building code, to decking prior to the installation.

3.3 INSTALLATION

- A. Install in accordance with manufacturer's instructions.
- B. See Timberlyne Drawings for more information.

- C. Only install enough H-Shield-NB per day that can be covered the same day by a completed roof covering material.

3.4 PROTECTION

- A. Protect installed products until completion of project.
- B. Touch-up, repair or replace damaged products before Substantial Completion.
- C. Cover the top and edges of unfinished roof panel work to protect it from the weather and to prevent accumulation of water in the cores of the panels.

END OF SECTION

SECTION 7350

SINGLE PLY ROOFING

1.0 GENERAL

1.01 RELATED WORK SPECIFIED ELSEWHERE

Rough Carpentry	Section 6100
Treated Wood	Section 6300

1.02 SCOPE OF WORK

1.02.1 Roofing work shall include roofing, insulation, and related work including flashings, new wood blocking for all areas of new construction as indicated on the drawings and as specified herein. All roofing at existing areas shall remain.

1.02.2 Installation Instructions: Provide manufacturer's instructions to installer, marked up to show exactly how all components will be installed; where instructions allow installation options, clearly indicate which option will be used.

1.03 SUBMITTALS

1.03.1 Submit manufacturer's data in accordance with the General Conditions and General Requirements and as outlined herein.

1.03.2 Samples: Submit samples of at least the following:

- .1 Sample of roof membrane.
- .2 Sample of walkway pads.
- .3 Sample of each insulation type.

1.03.3 Shop drawings shall include data for the following:

- .1 The roof membrane manufacturer's standard details customized for this project for all relevant conditions, including flashings, base tie-ins, roof edges, terminations, expansion joints, penetrations, and drains.
- .2 For tapered insulation, provide project-specific layout and dimensions for each board.

1.03.4. Submit specimen warranty prior to starting work and a letter from manufacturer attesting that the roofing installer meets the specified qualifications. Provide a copy of pre-installation notice to show that manufacturer's required Pre Installation Notice (PIN) has been accepted and approved by the manufacturer.

1.04 QUALITY ASSURANCE

1.04.1 Applicator Qualifications: Roofing installer shall have a current Elevate Master Contractor status and at least five years' experience in installing specified system and a minimum of 1,000,000 sf of low slope roofing under warranty with the same manufacturer.

1.04.2 Before start of roofing work, Contractor and roofing subcontractor shall hold a Pre-Installation Conference to discuss the proper installation of materials and requirements to achieve the warranty. Attendance of all parties directly influencing the quality of roofing work or affected by the performance of roofing work will be required.

1.04.3 Upon completion of the installation of the single ply roofing system, an inspection shall be conducted by a representative of the manufacturer of the roofing system, to ascertain that the roofing system has been installed according to the applicable manufacturer's specifications and details.

1.04.4 FM Listing: Provide sheet membrane, base flashings, and component materials that meet requirements of FM 1-28 and FM 1-29 as part of a roofing system and that are listed in FM's "Approval Guide" for Class 1 or noncombustible construction, as applicable. Identify materials with FM markings. Roofing system shall meet minimum requirements of FM 1-90 wind uplift rating.

1.05 DELIVERY, STORAGE AND HANDLING

1.05.1 Deliver products in manufacturer's original containers, dry and undamaged, with seals and labels intact and legible. Store materials clear of ground and moisture with weather protective covering. Keep combustible materials away from ignition sources.

1.06 WARRANTY

1.06.1 Comply with all warranty procedures required by manufacturer, including notifications, scheduling, and inspections. Provide Elevate 20 year Red Shield Limited Warranty covering membrane, roof insulation, membrane accessories, and metal edging and coping, with no dollar limitation. Warranty shall cover repair of leaks in the roofing system caused by the following:

- .1 Ordinary wear and tear of the elements.
- .2 Manufacturing defect in Firestone brand materials.
- .3 Defective workmanship used to install these materials.
- .4 Damage due to winds up to 55 mph.

Provide 20 year warranty for painted finish covering color fade, chalk, and film integrity of metal roof edging.

2.0 PRODUCTS

2.01 MANUFACTURERS

2.01.1 This specification is written around products as manufactured by Holcim Elevate. <http://www.holcimelevate.com> Systems as manufactured by Careslile Syntec Systems are also acceptable, subject to compliance with these specifications.

2.01.2 Materials as manufactured by others will not be permitted to be used.

2.02 ROOFING MEMBRANE

2.02.1 Roofing membrane shall be EPDM, 60 mils thick, reinforced, and shall be supplied in rolls of 10' wide x 100' length or maximum practical length. Color of membrane shall be black.

2.05 SHEET METAL FLASHING

2.05.1 Galvanized sheet metal shall be sheet steel, hot dip galvanized, commercial quality, and shall meet the requirements of ASTM A526 and ASTM A525 for G90 coating, and shall be mill phosphatized. Galvanized sheet metal shall be 24 gauge, unless other gauges or thicknesses are recommended by the SMACNA Manual or the sheet metal manufacturer.

2.05.2 Pre-finished sheet metal materials exposed to view shall have the same properties as the galvanized sheet metal specified above. Finish shall be a Kynar Fluoropolymer finish, which shall carry 20 year warranty.

2.06 RELATED MATERIALS

2.06.1 All related materials shall be as manufactured by the manufacturer of the roofing membrane, or as specifically recommended by the manufacturer. All components of the roofing system shall be as manufactured by a single manufacturer. Under no conditions will components of other manufacturers be allowed to be incorporated into the roofing system, which may affect the performance, watertightness or manufacturer's warranty.

2.06.2 Moisture-treated wood nailers shall be in accordance with the roofing system manufacturer's requirements, and shall be as specified in Section 6300 – Wood Treatment.

3.0 EXECUTION

3.01 INSPECTION AND ACCEPTANCE

3.02.1 Contractor shall inspect all roof deck, and report to the Architect, any defective material which is encountered. Commencement with the work by the roofing subcontractor shall constitute acceptance of the roof deck.

3.03 INSTALLATION

3.03.1 Install roofing, insulation, flashings, and accessories in accordance with roofing manufacturer's published instructions and recommendations for the specified roofing system. Where manufacturer provides no instructions or recommendations, follow good roofing practices and industry standards. Comply with federal, state, and local regulations. Obtain all relevant instructions and maintain copies at project site for duration of installation period.

3.03.2 Do not start work until Pre-Installation Notice has been submitted to manufacturer as notification that this project requires a manufacturer's warranty. Perform work using competent and properly equipped personnel.

3.03.3. Temporary closures, which ensure that moisture does not damage any completed section of the new roofing system, are the responsibility of the applicator. Completion of flashings, terminations, and temporary closures shall be completed as required to provide a watertight condition at the close of each work day.

3.03.4 Install roofing membrane only when surfaces are clean, dry, smooth and free of snow or ice; do not apply roofing membrane during inclement weather or when ambient conditions will not allow proper application; consult manufacturer for recommended procedures during cold weather. Do not work with sealants and adhesives when material temperature is outside the range of 60 to 80 degrees F.

3.03.5 Protect adjacent construction, property, vehicles, and persons from damage related to roofing work; repair or restore damage caused by roofing work.

- .1 Protect from spills and overspray from bitumen, adhesives, sealants and coatings.
- .2 Particularly protect metal, glass, plastic, and painted surfaces from bitumen, adhesives, and sealants within the range of wind-borne overspray.
- .3 Protect finished areas of the roofing system from roofing related work traffic and traffic by other trades.

3.03.6 Until ready for use, keep materials in their original containers as labeled by the manufacturer. Consult membrane manufacturer's instructions, container labels, and Material Safety Data Sheets (MSDS) for specific safety instructions. Keep all adhesives, sealants, primers and cleaning materials away from all sources of ignition.

3.04 PROTECTION

3.04.1 Where construction traffic must continue over finished roof membrane, provide durable protection and replace or repair damaged roofing to original condition.

SECTION 7411

METAL PANEL ROOFING SYSTEM

PART 1 GENERAL

The project, Pender Public Schools Sports Complex Building located in Pender, Nebraska, includes the provision of a complete Elevate roofing, wall, and lining systems UNA-CLAD™ UC-14 Self-locking, Concealed Clip, Standing Seam Metal Panel Roofing System.

1.01 SUMMARY

- A. Furnish and install concealed clip metal panel roofing system, including:
 - 1. Roofing manufacturer's requirements for the specified warranty.
 - 2. Preparation of roofing substrates.
 - 3. Wood nailers for roofing attachment.
 - 4. Insulation.
 - 5. Cover boards.
 - 6. Self-adhering underlayment.
 - 7. Metal roof edging and copings.
 - 8. Flashings.
 - 9. Other roofing-related items specified or indicated on the drawings or otherwise necessary to provide a complete roofing system.
- B. Disposal of demolition debris and construction waste is the responsibility of Contractor. Perform disposal in manner complying with all applicable federal, state, and local regulations.
- C. Comply with the published recommendations and instructions of the roofing system manufacturer, at www.holcimelevate.com.
- D. Commencement of work by the Contractor shall constitute acknowledgement by the Contractor that this specification can be satisfactorily executed, under the project conditions and with all necessary prerequisites for warranty acceptance by roofing system manufacturer. No modification of the Contract Sum will be made for failure to adequately examine the Contract Documents or the project conditions.

1.02 RELATED SECTIONS

- A. Section 6100 - Rough Carpentry:
 - 1. Roof Sheathing: Plywood or oriented strand board (OSB), minimum 7/16-inch (11 mm) thickness with H-clip or tongue-and-grooved joints.
 - 2. Perimeter wood members for attachment of edge trim.
 - 3. Wood nailers associated with roof insulation installed by others.
- B. Section 7600 - Sheet Metal Flashing and Trim: Formed metal flashing and trim items associated with non-metal roofing.

1.03 REFERENCES

- A. Referenced Standards: These standards form part of this specification only to the extent they are referenced as specification requirements.
 - 1. ASCE 7 - Minimum Design Loads for Buildings and Other Structures; American Society of Civil Engineers; 2011.
 - 2. ASTM A653/A653M - Standard Specification for Steel Sheet, Zinc-Coated (Galvanized) or Zinc-Iron Alloy-Coated (Galvannealed) by the Hot-Dip Process; 2011.
 - 3. ASTM C1177/C1177M - Standard Specification for Glass Mat Gypsum Substrate for Use as Sheathing; 2008.
 - 4. ASTM C1289 - Standard Specification for Faced Rigid Cellular Polyisocyanurate Thermal Insulation Board; 2013.

5. ASTM D1970/D1970M - Standard Specification for Self-Adhering Polymer Modified Bituminous Sheet Materials Used as Steep Roofing Underlayment for Ice Dam Protection; 2013.
6. ASTM E84 - Standard Test Method for Surface Burning Characteristics of Building Materials; 2013a.
7. ASTM E108 - Standard Test Methods for Fire Tests of Roof Coverings; American Society for Testing and Materials; 2011.
8. ASTM E136 - Standard Test Method for Behavior of Materials in a Vertical Tube Furnace At 750 Degrees C; 2012.
9. ASTM E1592 - Standard Test Method for Structural Performance of Sheet Metal Roof and Siding Systems by Uniform Static Air Pressure Difference; American Society for Testing and Materials; 2005 (Reapproved 2012)
10. ASTM E1646 - Standard Test Method for Water Penetration of Exterior Metal Roof Panel Systems by Uniform Static Air Pressure Difference; American Society for Testing and Materials; 1995 (Reapproved 2011).
11. ASTM E1680 - Standard Test Method for Rate of Air Leakage Through Exterior Metal Roof Panel Systems; American Society for Testing and Materials; 2011.
12. MBMA - Metal Roofing Systems Design Manual; Metal Building Manufacturers Association; 2012.
13. PS 1 - Construction and Industrial Plywood; 2009.
14. PS 20 - American Softwood Lumber Standard; 2010.
15. UL 580 - Standard for Tests for Uplift Resistance of Roof Assemblies; Underwriters Laboratories Inc.; Current Edition, Including All Revisions.
16. UL 2218 - Standard for Impact Resistance of Prepared Roof Covering Materials; Underwriters Laboratories Inc.; Current Edition, Including All Revisions.

1.04 SUBMITTALS

- A. Product Data: Submit manufacturer's data sheets on each product to be installed and manufacturer's standard detail drawings applicable to this project.
 1. Installation Instructions: Provide manufacturer's instructions to installer, marked up to show exactly how all components will be installed; where instructions allow installation options, clearly indicate which option will be used.
- B. Samples: Submit following samples for approval:
 1. 12 inch (300 mm) long sample of roof panel.
 2. Roof attachment clips.
 3. Color chips for selection of finish color and sheen.
 4. After selection of finish color, provide two 3- by 5-inch (75 by 125 mm) metal samples finished in color selected.
- C. Shop Drawings: Provide drawings prepared especially for this project for all relevant conditions, including plans and elevations, sections and details, specified loads, flashings, roof edges, terminations, expansion joints, curbs, penetrations, and drainage. Specifically include interfaces with materials not supplied by metal roof panel manufacturer and identify each component and its finish.
- D. Pre-Installation Notice: Copy to show that manufacturer's required Pre-Installation Notice (PIN) has been accepted and approved by the manufacturer.
- E. Manufacturer's Installation Inspection Reports: Manufacturer may, at its option, inspect the installation at any time to appraise the installing contractor of their compliance with manufacturer's requirements. Typical inspections will include:
 1. Prior to the installation of the metal roofing panels to inspect the underlayments. The roofing contractor is responsible for assuring that the substrate is in suitable condition for the installation of the metal roofing components to the substrate.
 2. Intermediate inspections to ensure proper installation of the metal roofing panels (if required).
 3. At final completion of all metal roofing system work.
 4. Submit to Owner, for the project record, a copy of each report of inspection made.

- F. Executed Warranty, by authorized company official upon final close-out.

1.05 QUALITY ASSURANCE

- A. Installer Qualifications: Roofing installer shall have received training from metal panel manufacturer for installation of the specified roof panel system, and:
 - 1. Current Elevate Red Shield™ licensed installer status.
 - 2. Having and using only equipment authorized and inspected by metal panel manufacturer.
- B. Pre-Installation Conference: Before start of roofing work, Contractor shall hold a meeting to discuss the proper installation of materials and requirements to achieve the warranty.
 - 1. Require attendance with all parties directly influencing the quality of roofing work or affected by the performance of roofing work.
 - 2. Notify Architect well in advance of meeting.

1.06 DELIVERY, STORAGE AND HANDLING

- A. Deliver products in manufacturer's original containers, dry and undamaged, with seals and labels intact and legible.
- B. Exercise extreme care in unloading, storing, and installing metal panels to prevent bending, warping, twisting, and surface damage.
- C. Store products above ground on well-supported platforms that provide minimum of 1:48 slope. Store under waterproof covering or indoors and provide proper ventilation of metal components to prevent condensation build-up between metal components.

1.07 WARRANTY

- A. Comply with all warranty procedures required by manufacturer, including notifications, scheduling, and inspections.
- B. Manufacturer's warranty is in addition to, and not a limitation of, other rights the owner may have under the contract documents.
- C. Warranty: Elevate Red Shield Limited Warranty covering roof panels and associated metal components, roof sheathing/insulation manufactured by Elevate roofing, wall, and lining systems, and accessories, covering weathertightness, finish, materials, labor, and workmanship.
 - 1. Limit of Liability: No dollar limitation.
 - 2. Scope of Coverage: Repair leaks in the roofing system caused by:
 - a. Ordinary wear and tear of the elements.
 - b. Manufacturing defect in Elevate brand materials.
 - c. Defective workmanship used to install these materials.
 - d. Damage due to winds up to 90 mph.
 - 3. Not Covered:
 - a. Materials made by entities other than Elevate roofing, wall, and lining systems.
 - b. Damage due to winds in excess of 90 mph.
 - c. Damage due hurricanes or tornadoes.
 - d. Hail.
 - e. Intentional damage.
 - f. Unintentional damage due to normal rooftop inspections, maintenance, or service.
- D. Painted Finish Warranty: Provide Elevate standard Red Shield non-prorated warranty covering durability of painted finish, to include film integrity, color change, fading, and chalking, unless otherwise indicated below.
 - 1. Warranty Period: 25 years commencing on date of substantial completion.
 - 2. Metallic Colors (as identified by Elevate roofing, wall, and lining systems): Not warranted against color change or fading.

3. Elevate Standard Color “Regal Red”: Warranted against color change or fading for a maximum period of ten (10) years.

PART 2 PRODUCTS

2.01 MANUFACTURERS

- A. Acceptable Manufacturer - Metal Roof Panels and Associated Sheet Metal Components: Elevate roofing, wall, and lining systems: www.holcimelevate.com.
 1. Provide all components of system supplied or specified by same manufacturer.
 2. Roofing systems manufactured by others may be acceptable provided the roofing system is completely equivalent in materials and warranty conditions and the manufacturer meets the following qualifications:
 - a. Specializing in manufacturing the roofing system to be provided.
 - b. Minimum ten years of experience manufacturing the roofing system to be provided.
 - c. Able to provide a no dollar limit, single source roof system warranty that is backed by corporate assets in excess of one billion dollars.
 - d. ISO 9001 certified.
 - e. Able to provide waterproofing membrane underlayment.
 - f. Able to provide polyisocyanurate insulation.
- B. Manufacturer of Insulation: Same manufacturer as metal roof panels.
- C. Substitutions: See Section 1 - Product Requirements.
 1. Submit evidence that the proposed substitution complies with the specified requirements.

2.02 ROOFING SYSTEM DESCRIPTION

- A. Roofing System: Standing seam metal roof panels and other components, together forming a watertight assembly having the following characteristics:
 1. Warranty: 20 year.
 2. Panel Seam Type: Self-locking; not requiring field seaming, concealed clip attachment to substrate.
 3. Panel Material: Steel, 24 gauge (0.64 mm) with fluoropolymer finish, over G90 hot-dipped galvanized coating.
 3. Color: To be selected from manufacturer’s standard and premium colors.
 4. Design Loads: In accordance with ASCE 7, current edition.
 - a. Design Snow Load: Not less than 20 psf (960 kPa).
 - b. Maximum Deflection Under Snow Load: Not more than L/180 or as recommended by ASCE 7, whichever is less.
 - c. Wind Uplift Resistance: Class 90 rating, minimum, when tested in accordance with UL 580.
 - d. Wind Pull-Off Resistance: No failure of roof panel or fasteners when tested in accordance with ASTM E1592 for negative loading equal to negative design wind load; for assemblies not tested, capacity for gauge, span, or loading may be determined by interpolating between test values only.
 5. Impact Resistance: Minimum of Class 4, when tested in accordance with UL 2218.
 6. Thermal Effects: Design roof panels and their attachment to allow free movement in response to expansion and contraction forces resulting from temperature variation, as specified in the MBMA Metal Roofing Systems Design Manual.
 7. External Fire Resistance: Class A or B when tested in accordance with ASTM E108 or UL 790.
 8. Provide all necessary members and connections, whether indicated in the manufacturer's standard detail drawings or not.
 9. Accessories and Their Fasteners: Capable of resisting the specified design wind uplift forces and allowing for thermal movement of the roof panel system, not restricting free movement of the roof panel system resulting from thermal forces except at designed points of roof panel fixity.
- B. Roof System Components: In order from the top down:
 1. Metal roofing panels and trim.
 2. Underlayment: Self-adhering, high temperature underlayment over entire roof; material as specified.
 3. Insulation cover board.

4. Nailbase: Oriented strand board or plywood, minimum 7/16 inch (11 mm) thick. 7 ¼" rigid insulation. R-32.
5. Permafelt Roof Underlayment
6. 1x8 (NOM) T&G DECKING
7. 4X6 DF#1 PURLINS

2.03 ROOF PANELS AND SHEET METAL FABRICATIONS

- A. Roof Panels: Elevate UNA-CLAD UC-14 Standing Seam Roofing; roll formed roofing panels produced in a permanent factory environment with fixed-base roll-forming equipment.
 1. Seam Height: 1-3/4 inches (44.5 mm).
 2. Seam Spacing (Panel Width): 18 inches (475.2 mm), optimal.
 2. Profile: Flat Ribs
 3. Texture: Smooth.
 4. Provide factory applied integral seam sealant in leg of panel.
 5. Concealed clips as tested and supplied by manufacturer.
 6. Form roofing panels in longest practical lengths, true to shape, accurate in size, square, and free from distribution or manufacturing defects.
- B. Steel Sheet: ASTM A653/A653M, lock-forming quality, extra smooth, tension-leveled, galvanized/galvannealed steel, minimum spangle.
- B. Fluoropolymer Coating: 70 percent full strength Kynar 500/Hylar 5000.
 1. Exposed Surface: 1.0 mil (0.25 mm) plus/minus 0.1 mil (0.025 mm) total dry film thickness.
 2. Concealed Surface: 0.2 to 0.3 mils (0.05 to 0.08 mm) total dry film thickness.
 3. Color: To be selected from manufacturer's standard and premium colors.
- C. Sheet Metal Components Associated with Metal Roof Panels: Made by same manufacturer and compatible with roof panels; of not less than minimum thickness required by roof panel manufacturer.
 1. Fabricate trim, flashing, and accessories to roofing manufacturer's specified or approved profiles.
 2. Exposed metal components of same finish as panels.
 3. Color: Same as panels.
 4. Provide the following formed sheet metal components:
 - a. Eave.
 - b. Ridge.
 - c. Hip.
 - d. High eave.
 - e. Rake edge.
 - f. Vertical fascia.
 - g. Side wall flashing.
 - h. Pipe and other penetration flashings, for penetrations over 8 inches.
 - i. Flashings at interface to other roofing types.
 - j. Other flashings.

2.04 ROOF INSULATION AND COVER BOARDS

- A. Composite OSB/Polyisocyanurate Foam Insulation Boards: Closed cell polyisocyanurate foam complying with ASTM C1289 Type I Class 1, laminated to oriented-strand board, with black glass-fiber-reinforced mat on other face, with the following additional characteristics:
 1. OSB Thickness: 7/16 inch (11 mm) thick.
 2. Foam Thickness: As indicated elsewhere.
 3. Foam Compressive Strength: 20 psi (138 kPa) when tested in accordance with ASTM C1289.
 4. Recycled Content -- Foam Component: 19 percent post-consumer and 15 percent post-industrial, average.
 5. Acceptable Product: HailGard™ (Nailbase) Insulation by Elevate roofing, wall, and lining systems.
- B. Insulation/Cover Board Fasteners: Type and size as required by roof system manufacturer for roofing system and warranty to be provided; use only fasteners furnished by roof system manufacturer.

2.05 ACCESSORY MATERIALS

- A. Self-Adhered Underlayment: Rubberized sheet waterproof membrane complying with ASTM D 1970/D1970M, self-adhering.
 - 1. Resistance to Direct Exposure: At least 90 days.
 - 2. Minimum High Temperature Resistance: 230 degrees F (110 degrees C).
 - 3. Water Vapor Permeance: 0.1 perm (5.7 ng/(Pa s sq m)), maximum.
 - 4. Acceptable Product: Clad-Gard™ SA by Elevate roofing, wall, and lining systems
- B. Fasteners: In strict accordance with metal roof panel manufacturer's requirements; minimize exposed fasteners.
 - 1. Fasteners Exposed to Weather: Sealed or with sealed washers on exterior side of covering to waterproof fastener penetration; washer material compatible with screw head; minimum 3/8-inch (9.5 mm) diameter washer for structural connections; gasket portion of fasteners or washers made of EPDM, neoprene, or other equally durable elastomeric material.
 - 2. Fasteners Exposed to View: Head of color matching panel or component in which installed.
- C. Installation Clips: Manufacturer standard galvanized or stainless-steel clips, as required by panel selection, for concealed securement of panels. Use only those approved for use by the roof system manufacturer.

PART 3 INSTALLATION

3.01 GENERAL

- A. Install roofing, insulation, flashings, and accessories in accordance with roofing manufacturer's published instructions and recommendations for the specified roofing system. Where manufacturer provides no instructions or recommendations, follow good roofing practices and industry standards. Comply with federal, state, and local regulations.
- B. Obtain all relevant instructions and maintain copies at project site for duration of installation period.
- C. Verify that shop drawings prepared by metal roof panel manufacturer have been approved and are available to installers; do not use drawings prepared by others for installation drawings.
- D. Verify that the specifications and drawing details are workable and not in conflict with the roofing manufacturer's recommendations and instructions; start of work constitutes acceptable of project conditions and requirements.
- E. Do not start work until Pre-Installation Notice has been submitted to manufacturer as notification that this project requires a manufacturer's warranty.
- F. Perform work using competent and properly equipped personnel.
- G. Temporary closures, which ensure that moisture does not damage any completed section of the new roofing system, are the responsibility of the applicator. Completion of flashings, terminations, and temporary closures shall be completed as required to provide a watertight condition.
- H. Install roofing only when surfaces are clean, dry, smooth, and free of snow or ice; do not apply roofing during inclement weather or when ambient conditions will not allow proper application; consult manufacturer for recommended procedures during cold weather. Do not work with sealants and adhesives when material temperature is outside the range of 60 to 80 degrees F (15 to 25 degrees C).
- I. Protect adjacent construction, property, vehicles, and persons from damage related to roofing work; repair or restore damage caused by roofing work.
 - 1. Protect from spills and overspray from bitumen, adhesives, sealants, and coatings.
 - 2. Particularly protect metal, glass, plastic, and painted surfaces from bitumen, adhesives, and sealants within the range of wind-borne overspray.
 - 3. Protect finished areas of the roofing system from roofing related work traffic and traffic by other trades.
- J. Until ready for use, keep materials in their original containers as labeled by the manufacturer.
- K. Consult panel manufacturer's instructions, container labels, and Safety Data Sheets (SDS) for specific safety instructions. Keep all adhesives, sealants, primers, and cleaning materials away from all sources of ignition.

3.02 EXAMINATION

- A. Examine roof deck to determine that it is sufficiently rigid to support installers and their mechanical equipment, and that deflection will not strain or rupture roof components or deform deck.
- B. Verify that surfaces and site conditions are ready to receive work. Correct defects in the substrate before commencing with roofing work.
- C. Verify that the substructure installation is in accordance with the approved shop drawings and roof panel manufacturer's requirements, that the fasteners are correct for the substrate, and the substrate is installed to accommodate and support the appropriate clip spacing and attachment.
- D. Verify that installed work of other trades that such work is complete to a point where the roofing system installation may commence.
- E. Verify that roof openings, curbs, pipes, sleeves, ducts, vents, and other penetrations through roof substrate are complete and properly located.
- F. In event of discrepancy, notify Architect in writing; do not proceed with installation until discrepancies have been resolved.

3.03 INSULATION INSTALLATION

- A. Install insulation over entire area to be roofed, mechanically fastened as required by roofing manufacturer.
- B. Provide wood nailers at all perimeters of insulation and at other locations where indicated on the drawings, of total height matching the total thickness of insulation being used.
 - 1. Install with 1/8-inch (3 mm) gap between each length and at each change of direction.
 - 2. Mechanically fasten to deck to resist force of 200 lbf per linear foot (35 kN/m).

3.04 COVER BOARD INSTALLATION

- A. Install cover board over entire area to be roofed, mechanically fastened as required by roofing manufacturer.

3.05 UNDERLAYMENT INSTALLATION

- A. Install underlayment in accordance with manufacturer's instructions.
- B. Install self-adhered underlayment over entire roofing surface.

3.06 ROOF PANEL INSTALLATION

- A. Install the metal roof panel system in accordance with the manufacturer's instructions, installation drawings, and approved shop drawings, so that it is weathertight and allows for thermal movement.
- B. Locate space and fasten all clips in accordance with roof panel manufacturer's recommendations. For required fasteners, use proper torque settings to obtain controlled uniform compression for a positive seal without rupturing the sealing washers.
- C. Do not place utility penetrations through the panel seams.
- D. Do not allow panels or trim to come into contact with dissimilar materials (i.e., copper, lead, graphite, treated lumber, mortar, etc.). Protect from water run-off from these materials.
- E. Perform field cutting of panels and related sheet metal components by means of hand or electric shears. At no time shall a hot/friction saw be used.
- F. Remove protective film immediately after installation.

3.07 FLASHING AND ACCESSORIES INSTALLATION

- A. Install flashings, including laps, splices, joints, bonding, adhesion, and attachment, as required by roof panel manufacturer's recommendations and details.
- B. Install metal trim, accessories, and edgings in locations indicated on the drawings.
 - 1. Follow roofing manufacturer's instructions.
 - 2. Remove protective plastic surface film immediately before installation.
- C. Flashing at Walls, Curbs, and Other Vertical and Sloped Surfaces: Install weathertight flashing at all walls, curbs, parapets, curbs, skylights, and other vertical and sloped surfaces that the roofing system abuts to; extend flashing at least 8 inches high above system surface.

- D. Flashing at Penetrations: Flash all penetrations passing through the panel; make flashing seals directly to the penetration.
 - 1. Pipes, Round Supports, and Similar Items: Flash with specified pre-molded pipe flashings wherever practical.
 - 2. Where pre-molded pipe flashings are not practical, provide flashing detail as recommended by metal panel manufacturer.

3.08 FIELD QUALITY CONTROL

- A. Inspection by Manufacturer: Provide final inspection of the roofing system by a Technical Representative employed by roofing system manufacturer specifically to inspect installation for warranty purposes (i.e., not a salesperson).
- B. Perform all corrections necessary for issuance of warranty.

3.09 ADJUSTING AND CLEANING

- A. Repair panels having minor damage.
- B. Remove panels damaged beyond repair and replace with new panels to match adjacent undamaged panels.
- C. Clean exposed panel surfaces promptly after installation in accordance with recommendations of panel and coating manufacturers.
- D. Clean all contaminants generated by roofing work from building and surrounding areas, including adhesives, sealants, and coatings.
- E. Repair or replace building components and finished surfaces damaged or defaced due to the work of this section; comply with recommendations of manufacturers of components and surfaces.
- F. Remove leftover materials, trash, debris, equipment from project site and surrounding areas.

3.10 PROTECTION

- A. Where construction traffic must continue over finished roof panels, provide durable protection, and replace or repair damaged roofing to original condition.

END OF SECTION

SECTION 7600

FLASHING AND SHEET METAL

1.0 GENERAL

1.01 QUALITY ASSURANCE

1.01.1 SMACNA Standards. Except as otherwise shown, detailed, or specified, flashing and sheet metal work shall comply with applicable recommendations and details of the American Sheet Metal Manual of the Sheet Metal and Air Conditioning Contractors National Association.

1.02 SUBMITTALS

1.02.1 Submit shop drawings to the Architect in accordance with the General Conditions and General Requirements. Shop drawings shall show the manner of forming, jointing, and securing of flashing and sheet metal.

2.0 PRODUCTS

2.01 SHEET METAL MATERIALS

2.01.1 Galvanized sheet metal shall be sheet steel, hot dip galvanized, commercial quality, and shall meet the requirements of ASTM A526 and ASTM A525 for G90 coating, and shall be mill phosphatized. Galvanized sheet metal shall be 26 gauge unless other gauges or thicknesses are recommended by the SMACNA Manual or the sheet metal manufacturer, shown on the drawings, or specified herein.

2.01.2 Pre-finished sheet metal materials exposed to view shall have the same properties as the galvanized sheet metal specified in paragraph 2.01.1 above. Finish shall be a Kynar Fluoropolymer finish, which shall carry a 20 year manufacturer's warranty against defects in the finish including failure of the bond between the finish and the substrate, and peeling, cracking, crazing and other imperfections.

2.02 FASTENERS

2.02.1 Nails shall be not less than No. 12 gauge, with large flat heads, diamond points, and barbed shafts, and of sufficient length to penetrate substrate at least 7/4 inch. Nails shall be hot dipped galvanized steel, and shall be installed such that they are concealed when the installation of the flashing is complete.

2.03 SHEET METAL SPECIALTIES

2.03.1 Gutters shall be high back, 6 inch, Style "K", pre-finished steel as indicated on the drawings, with outlet tubes and strainers as shown in the SMACNA manual. Gutters shall be job fabricated, seamless, with expansion joints at gutters for lengths in excess of 40 feet.

2.03.2 Downspouts shall be fabricated from corrugated pre-finished steel 4" x 5", complete with elbows and hangers, located where indicated on the drawings.

2.03.3 Where downspouts transition to underground drainage piping, provide transition from 4" x 5" downspout to 6" diameter poly piping with a poly transition device. Top of transition device shall be installed 2 inches above concrete or grade.

2.04 FABRICATION

2.04.1 General Fabrication. Fabricate all work with lines and corners true and accurate. Form exposed faces flat and free of buckles, excessive waves, and avoidable tool marks, considering the temper and reflectivity of the metal. Provide uniform neat seams with minimum exposure of solder, welds, or sealant. Fold back sheet metal to form a hem on the concealed side of exposed edges and provide soldered flat-lock seams unless otherwise shown or

specified. Follow the metal manufacturer's recommendations for tinning, soldering, welding, and cleaning flux from metal.

2.04.2 Form miscellaneous items as shown on the drawings and install with clips, cleats or other fasteners as required.

2.04.3 Gutter apron shall be 26 gauge galvanized sheet metal, extending 4 inches minimum onto roof, with drip leg bent toward outside of gutter at bottom of flashing.

3.0 EXECUTION

3.01 INSPECTION

3.01.1 Substrate condition shall be smooth, free from defects, dust, rubbish, and other foreign material and with projecting nails driven flush.

3.02 INSTALLATION

3.02.1 Install work with lines and corners true and accurate in alignment. Install faces flat and free of buckles, excessive waves, and avoidable tool marks, considering the temper and reflectivity of the metal. Provide uniform neat seams with minimum exposure of solder, welds, or sealant. Fold back sheet metal to form a hem on the concealed side of exposed edges. Follow the metal manufacturer's recommendations for tinning, soldering, welding, and cleaning flux from metal.

3.02.2 SMACNA and Manufacturers Details. Install the work to meet the recommendations shown in the SMACNA Manual and the recommendations of the sheet metal manufacturer, except when otherwise shown or specified.

3.02.3 Conceal fasteners and expansion provisions wherever possible in exposed work and locate to minimize the possibility of leakage. Cover and seal work for a watertight installation. Provide cleat-type anchorages for metal flashing and trim wherever practical, arranged to relieve stresses resulting from building movement and thermal expansion.

3.02.4 Provide for thermal expansion in items which exceed 15 feet in length for general flashing materials, and 40 feet in length for gutters. Expansion joints shall be watertight, and shall be located as approved by the Architect.

3.02.5 Overlaps at miscellaneous flashing shall be 3 inches at vertical surfaces, and 6 inches at all horizontal surfaces.

3.02.6 Install manufactured items in accordance with the manufacturer's recommendations, and as indicated on the drawings.

3.02.7 Downspouts shall extend full depth into poly transition device. Coordinate with installation of underground drainage piping contractor.

3.03 CLEANING AND PROTECTION

3.03.1 Touch up abraded surfaces where pre-finished coating has been damaged with paint to match pre-finished coating, supplied by the manufacturer of the pre-finished roll stock.

3.03.2 Clean exposed surfaces of substances which are visible or which might cause corrosion of metal or deterioration of the finish.

SECTION 7900

SEALANTS

1.0 GENERAL

1.01 SUBMITTALS

1.01.1 Submit shop drawings to the Architect in accord with the General Conditions and General Requirements, including color samples for each type of sealant.

1.02 JOB CONDITIONS

1.02.1 Weather and Temperature. Install sealants on dry days with temperatures 40 degrees F., minimum.

1.02.2 Protection. Exercise special care to prevent damage to adjacent work during installation of sealants.

1.02.3 Sequencing.

- .1 Install sealants adjacent to painted surfaces before adjacent surfaces receive their final coat of paint.
- .2 Door frames at resilient flooring, caulk between floor and frames after installation of floor finish material.
- .3 At gypsum board control joints at fire rated walls/ceilings, install fire rated caulking in openings prior to installation of metal control joints.

2.0 PRODUCTS

2.01 MATERIALS

2.01.1 Thermosetting paving sealants shall be one-part polysulfide (Thiokol) or polyurethane sealants of the following types and manufacturers:

Sonlastic Paving Joint Sealant	(Sonneborn) Contech, Inc.
Vulkem 200, or Vulkem 245	Mameco International
Pourthane Sealant	W. R. Meadows, Inc.
NR 100 or 200 Urexpam Sealant	Pecora Corporation

2.01.2 Thermosetting building sealants shall be one-part or two-part polysulfide (Thiokol), polyurethane, or silicone sealants of the following type and manufacture:

Sonolastic NP I or II	(Sonneborn) Contech, Inc.
Sonolastic Sealant (one or two part)	(Sonneborn) Contech, Inc.
Vulkem 116, or 227	Mameco Corporation

2.01.3 Fire caulking shall be Fire Stop Sealant 2000 as manufactured by DOW. Products as manufactured by General Electric, Hilde or Tremco are also acceptable, subject to compliance with fire rating requirements.

2.01.4 Primer shall be of the type and manufacture recommended by the sealant manufacturer for use with the sealant specified and the abutting materials.

2.01.5 Backer rods shall be closed-cell polyethylene or an open cell polyurethane rod as recommended by the sealant manufacturer, of a diameter 1/8 inch greater than the joint width up to 3/4 inch diameter, and 1 1/4 inch diameter for 1 inch joints.

2.01.6 Bond breaker, where required to break the bond between the sealant and the back-up material or joint filler, shall be a tape material recommended by the sealant manufacturer, or shall be polyethylene film.

3.0 EXECUTION

3.01 PREPARATION

3.01.1 Clean down joint surfaces, using oil free solvent for metal, glass, and other non-porous surfaces, and by wire brushing concrete and masonry surfaces. Surfaces to receive sealant shall be sound, clean, and dry, and free of frost, laitance, curing compounds, waterproofing compounds, mastic compounds, corrosion, mill scale, rust, oil, tar, wax, mastic, and similar contaminants. Sand blast concrete in contact with form release agents.

3.01.2 Mask adjacent areas if necessary to obtain a neat sealant line.

3.01.3 Prime concrete, masonry, wood and similar porous surfaces. Brush out excess material to insure a uniform film over the whole joint face. Allow primer to dry out before applying sealant.

3.02 INSTALLATION

3.02.1 Install backer rod with a blunt rod or plain faced roller. Recess into joint to meet the requirements of the sealant manufacturer's recommendations. Do not puncture, fold, twist, or crease backer rod.

3.02.2 Install bond breaker where sealant would otherwise bond to backer rod or joint filler.

3.02.3 Installation of Cold Applied Sealants. Apply sealant, holding the gun nozzle at an angle of about 45 degrees, and move steadily along the joint so that a uniform bead is applied without dragging, tearing, or leaving unfilled spaces. Push the bead rather than draw it with the gun leading. Fill joints in vertical surfaces level with adjacent surfaces and tool within ten minutes of application with one continuous stroke to insure intimate contact with the joint faces, to remove any trapped air or voids, to consolidate material, and to provide a neat, uniform appearance. Fill joints in horizontal surfaces holding the top surface of the sealant slightly below the adjacent surfaces.

3.03 CLEANING AND PROTECTION

3.03.1 Cleaning. Remove masking immediately after application and tooling operations are complete. Clean excess or spilled sealant from non-porous surfaces with solvent before curing. Clean excess or spilled sealant from porous surfaces with abrasive or mechanical means after curing.

3.01.2 Protect sealant where bituminous material is to be applied over thermosetting joint sealant with vinyl or polyethylene sheet material.

3.04 SCHEDULE OF APPLICATION

3.04.1 Apply thermosetting paving sealant at the following locations:

- .1 At walk and paving control joints (sawn joints, and construction joints) and expansion joints,
- .2 Where walks abut structural slabs, stoops, or building walls,
- .3 Where sealant is shown on drawings for concrete slabs.

3.04.2 Apply thermosetting building sealants at the following locations:

- .1 At exterior control joints,
- .2 At framed openings at exterior walls, including sills and thresholds,
- .3 Where tight joints are required between masonry and built in materials,
- .4 At miscellaneous locations where caulking is shown on drawings,
- .5 At water closet/floor finish juncture, all around,
- .6 At vanity/wall juncture, all around,
- .7 At hollow metal door frame-to-wall and frame-to-floor finish, for all floor finishes except carpet.

3.04.3 Apply fire caulking at the following locations:

- .1 At gypsum board control joints in fire rated walls/ceilings, prior to installation of the metal joint (fire rated caulking),
- .2 At conduits, piping, ductwork and other locations where building systems penetrate fire rated walls, caulk between penetration and gypsum board.

SECTION 8100

METAL DOORS AND FRAMES

1.0 GENERAL

1.01 RELATED WORK SPECIFIED ELSEWHERE

Sealants	Section 7900
Prefinished Steel Door Frames	Section 8110
Hardware	Section 8700
Wood Doors	Section 8210
Hardware	Section 8700

1.02 HARDWARE TEMPLATES

1.02.1 Hardware templates shall be furnished to the fabricator by the hardware manufacturer. The fabricator shall drill and tap holes and make cutouts and reinforcement in frames and doors to receive hardware in a neat and proper manner.

1.03 REQUIREMENTS OF REGULATORY AGENCIES

1.03.1 Labeled Doors and Frames. Where noted or shown on the Drawings, furnish doors and frames bearing the label of Underwriters Laboratories or Factory Mutual Engineering Corp., indicating the applicable rating and wall opening classification specified.

1.04 SUBMITTALS

1.04.1 Submit shop drawings to the Architect in accord with the General Conditions and General Requirements. Shop drawings shall show quantities, types, and locations. Door and frame construction shall be fully detailed showing weights of material, finish, framing, reinforcing, method of making joints and cutouts, and must indicate conformance with specified technical requirements.

1.04.2 Coordination. The frame subcontractor shall coordinate his requirements with the glazing subcontractor to assure that frames are provided with required bite, edge, and face clearance. Verify with glazing subcontractor requirements for muntin bars, to ascertain if muntin bars are to be installed internally, between panes of glass, or externally, on the face of glass integrally with stops.

1.05 DELIVERY, STORAGE AND HANDLING

1.05.1 Delivery and Storage. Doors shall be shipped individually packed. Welded frames shall be shipped with angle spreaders at door opening bottoms. Doors and frames shall be stored on the building site, in an upright position, under cover, on wood sills or floors, in a manner that will prevent rust or damage. Ventilate canvas or plastic covers to prevent moisture traps.

2.0 PRODUCTS

2.01 HOLLOW METAL DOORS

2.01.1 Face Sheets and Fillers. Fabricate doors from galvanized steel. Face sheets shall be 18 gauge galvanized steel. Provide insulated doors with polyurethane cores where scheduled on the Drawings.

2.01.2 Top and bottom edges shall be 16 gauge steel channels. The back of the channel shall be flush with the top and bottom of face sheets. Inverted channels, if used, shall have filler caps. Tops shall be smooth and flush.

2.01.3 Hardware Preparation. Doors shall be mortised, reinforced, drilled, and tapped for scheduled mortise hardware and reinforced for scheduled surface-applied hardware. Hinge reinforcing shall be 7 gauge or heavier steel plate. Closer reinforcing shall be minimum 12 gauge steel, and other reinforcing shall be 14 gauge steel.

2.01.4 Welds shall be ground invisible, and depressions shall be filled smooth.

2.01.5 Shop Paint. After fabrication, doors shall be thoroughly cleaned and degreased, phosphatized, and painted with a rust-inhibitive primer.

2.02 HOLLOW METAL FRAMES FOR DOORS

2.02.1 Fabricate pressed metal frames of 16 gauge steel, formed to types and profiles as shown on the Drawings. Breaks, angles, and arises shall be uniform, straight, sharply defined, and true. All frames shall be welded one piece frames, with corners mitered, welded, and ground smooth.

2.02.2 Jamb Anchors. Welded one piece frames shall have wood stud type anchors, three per jamb for anchoring into wood framing, in accordance with manufacturer's instructions and as detailed on the drawings.

2.02.3 Reinforcing. Butt, closer, and holder reinforcing shall be minimum 14 gauge for strike, 12 gauge for closer, and 7 gauge steel for butts. Frames shall be mortised, reinforced, drilled, and tapped for scheduled mortise hardware, and shall be reinforced for surface-applied hardware. Weld dust covers over drilled reinforcements.

2.02.4 Shop Paint. After fabrication, frames shall be thoroughly cleaned and degreased, phosphatized, and painted with a rust-inhibitive primer.

2.04 PREFINISHED STEEL DOOR FRAMES

2.04.1 See Section 8110.

3.0 EXECUTION

3.01 INSTALLATION

3.01.1 Install frames plumb, square, straight, true, rigidly secured in place, and properly braced. Anchor frames securely to floor and jamb openings. Hang hollow metal doors, preserving clearances.

SECTION 8110

PREFINISHED STEEL DOOR FRAMES

1.0 GENERAL

1.1 SECTION INCLUDES

- A. Prefinished steel frames for interior doors.
- B. Prefinished steel frames for exterior doors.

1.2 RELATED SECTIONS

Rough Carpentry	Section 6100
Finish Carpentry	Section 6200
Metal Doors and Frames	Section 8100
Door Hardware	Section 8700
Glazing	Section 8800
Painting	Section 9800

1.3 REFERENCES

- A. ASTM International (ASTM):
 - 1. ASTM A1008/A1008M Standard Specification for Commercial Steel (CS) Sheet, Carbon (0.15 Maximum Percent) Cold-Rolled.
 - 2. ASTM A653 - Standard Specification for Steel Sheet, Zinc-Coated (Galvanized) or Zinc-Iron Alloy-Coated (Galvannealed) by the Hot-Dip Process.
 - 3. ASTM B117 - Standard Practice for Operating Salt Spray (Fog) Apparatus.
 - 4. ASTM D1735 - Standard Practice for Testing Water Resistance of Coatings Using Water Fog Apparatus.
 - 5. ASTM D3363 - Standard Test Method for Film Hardness by Pencil Test.
- B. American National Standards Institute (ANSI):
 - 1. ANSI/BHMA A156.115 Specifications for Steel Door and Frame Preparation for Hardware.
- C. National Fire Protection Association (NFPA):
 - 1. NFPA 80 - Fire Doors and Windows.
- D. Underwriters Laboratories, Inc. (UL):
 - 1. UL 10B - Fire Tests of Door Assemblies.
 - 2. UL 10C - Positive Pressure Fire Tests of Door Assemblies.

1.4 SUBMITTALS

- A. Product Data: Submit product data, including manufacturer's product sheet, for specified products. Include details of design and construction and printed instructions covering installation.
- B. Shop Drawings: Submit shop drawings showing layout, profiles and product components, including anchorage, accessories, finish colors and textures. Indicate installation requirements of finish hardware and reinforcements.
- C. Selection Samples: Submit the following for selection of finishes, colors and textures.
 - 1. Samples of factory stocked colors of prefinished components.
 - 2. Samples of custom colors for color matching.
- D. Quality Assurance Submittals: Submit the following:
 - 1. Test Reports: Certified test reports showing compliance with specified performance

- characteristics and physical properties.
- 2. Certificates: Manufacturer's certification that installer is acceptable.
- 3. Warranty: Submit the warranty documents specified.

1.5 QUALITY ASSURANCE

- A. Manufacturer Qualifications: Minimum 5 year experience manufacturing similar products.
- B. Installer Qualifications: Installer experienced in performing work of this section who has specialized in the installation of work similar to that required for this project.
 - 1. Personnel: Assembly and installation shall be performed by qualified personnel who have successfully completed manufacturer's prefinished steel door frame installation course online and have been approved by the manufacturer.
- C. Regulatory Requirements: Fire-rated steel frames shall be of types tested and approved by Intertek Testing Services, Warnock Hersey and shall bear labels of same.
 - 1. Three-sided frames shall receive a permanent embossed 90 minute label. Sidelite and borrowed lite frames shall receive a Mylar Warnock Hersey label when required by Authority having Jurisdiction (AHJ).
 - 2. 1-1/2 hour fire rating assembly in accordance with UL 10C.
 - 3. Assembly passes positive pressure test in accordance with UL 10C.

1.6 PRE-INSTALLATION MEETINGS

- A. Convene minimum two weeks prior to starting work of this section.

1.7 DELIVERY, STORAGE, AND HANDLING

- A. Delivery: Deliver materials in manufacturer's original, unopened, undamaged containers with identification labels intact.
 - 1. Factory package components in protective cartons to prevent damage during shipping.
- B. Storage and Protection: Store materials protected from exposure to harmful weather and at temperature conditions recommended by manufacturer.
 - 1. Store material on wooden skids under cover in a protected area and keep vented to avoid condensation until ready for installation.
- C. Handling: Handle materials to avoid damage.

1.8 PROJECT CONDITIONS

- A. Maintain environmental conditions (temperature, humidity, and ventilation) within limits recommended by manufacturer for optimum results. Do not install products under environmental conditions outside manufacturer's recommended limits.

1.9 SEQUENCING

- A. Field Measurements: Verify actual measurements/openings by field measurements before fabrication. Show recorded measurements on shop drawings. Coordinate field measurements and fabrication schedule with construction progress schedule to avoid construction delays.
- B. Ensure that products of this section are supplied to affected trades in time to prevent interruption of construction progress.

1.10 WARRANTY

- A. Manufacturer's Warranty: Submit manufacturer's standard warranty document executed by authorized company official. Manufacturer's warranty is in addition to, and not a limitation of, other rights

Owner may have under the Contract Documents.

1. Warranty Period: 1 year.

PART 2 PRODUCTS

2.0 MANUFACTURERS

- A. Acceptable Manufacturer: Dunbarton Corporation, which is located at: 1101 Technology Dr.; Dothan, AL 36303; Toll Free Tel: 800-633-7553; Tel: 334-794-0661; Fax: 334-793-7022; Email:[request info \(davidgz@dunbarton.com\)](mailto:requestinfo@davidgz@dunbarton.com); Web:<http://www.dunbarton.com>
- B. Requests for substitutions will be considered in accordance with provisions of Section 01 60 00 - Product Requirements.

2.1 PERFORMANCE REQUIREMENTS

- A. 1-1/2 Hour fire rating in accordance with UL 10B.
- B. Passes positive pressure test in accordance with UL 10C.

2.2 MANUFACTURED UNITS

- A. General: Frames shall be prefinished type designed for installation at rough wall openings over prefinished walls. Frames shall be designed for installation by sleeving the frame over the finish wall and placing screws through the face of the frame;
 1. Frames shall be Rediframe Adjustable Throat RFX Series Steel Door Frame as manufactured by Dunbarton Corporation.
 2. Frames shall be Rediframe DW Hollow Metal Drywall Frame:
 - a. 18 or 16-Gauge, A-40 galvanized.
 - b. Knock-down design.
 - c. Welded-in compression anchors.
 - d. Non-Kerf Frame: 5-1/2 inches to 10 inches (140 mm to 254 mm).
 - e. Kerf Frame: 5-1/2 inches to 9-1/2 inches (140 mm to 241 mm).
 - f. Hinge Preps: 4 inches x 1/4 inch (102 mm x 6 mm) radius, 4 inches x 5/8 inch (102 mm x 16 mm) radius, 4-1/2 inches (114 mm) square corner. Refer to hardware Schedule.
 - g. Strike Preparation: T-Strike, ASA, and deadbolt.
 - h. Built-in strike dust boxes (standard).
 3. Frames shall be rated as level A for physical endurance (1,000,000 cycles).
 4. Application: Refer to Door and Frame Types in the drawings.
 5. Throat Depth: Refer to Door Schedule and Door Elevations in the Drawings.
 6. Provide steel frames to receive decorative wood moldings to conceal fasteners.
 7. Provide accessories and fasteners necessary for field assembly and installation in accordance with frame manufacturer's standards.
 8. Prepare for and provide reinforcements in accordance with manufacturer's standards as required to receive finished hardware.
- B. Door Frames:
 1. Construct jamb member to interlock and align with header members to form a strong joint.
- C. Hardware Preparations:
 1. In accordance with an approved Hardware Schedule, ANSI/BHMA A156.115 and manufacturer's recommendations:
 - a. Mortise frames for hinges and strikes.
 - b. Drill and tap or reinforce frames for mortised or surface mounted hardware.
 2. Frames for 1-3/4 inches (44 mm) door frames are embossed for standard template butt hinges from 4 inches x 4 inches (102 x 102 mm) to 4 inches x 5 inches (102 x 127 mm).
 3. 1 3/4 inches (44 mm) frames are embossed for adjustable 4-7/8 inches (124 mm) ASA

- universal strike (patented) or for 2-3/4 inches (70 mm) adjustable T strike.
4. Frames for 1-3/8 inches (35 mm) doors are embossed for 3-1/2 inches x 1/4 inches (89 x 6.4 mm) or 3-1/2 inches x 5/8 inches (89 x 15.9 mm) radius standard weight template hinges and 2-3/4 inches (70 mm) cylindrical lock strike

2.3 FINISHES

- A. Frames Finish: To be selected by architect/owner from standard colors.

2.4 MATERIALS

- A. Header and Jamb Members: Form interior door frames of ASTM A1008/A1008M commercial quality cold rolled steel. Form exterior door frames of galvanized steel (A40) per ASTM A653. Provide frames in the following gauges:
 1. Fire Rated Frames for 1 3/4 Inch (44 mm) Doors: 18 gage. Refer to Door Schedule.
 2. Fire Rated Frames for 1 3/4 Inch (44 mm) Doors: 20 gage. Refer to Door Schedule.
 3. 1-3/4 Inches (44 mm) Door Frames: 18 gauge.
 4. 1-3/4 Inches (44 mm) Door Frames: 16 gauge.
- B. Hinge Reinforcements: 14 gage hot dipped galvanized (G60) steel to ASTM A653 (10 gage equivalent number of threads, SDI-107).
- C. Strikes and Deadbolt Covers and Dust Box: 18 gage commercial quality cold rolled steel to ASTM A1008/A1008M.
- D. Door Closer Reinforcement: Steel or aluminum in accordance with manufacturer's standard.
 1. Standard Arm Mounting: Aluminum extrusion 6063-T5 alloy in accordance with manufacturer's standard.
 - a. Door Guard: Aluminum extrusion 6063-T5 alloy in accordance with manufacturer's standard.
 2. Parallel Arm Mounting: 16 gage galvanized (A40) steel per ASTM A653.
- E. Casing Corner Alignment Clips: Pre-painted 22 gage ASTM A1008/A1008M commercial quality cold rolled steel.
- F. Felt Silencers, Weatherstripping and Smoke Gasketing (Standard Profile): In accordance with manufacturer's standard.
 1. Interior Frames: Install felt silencers on the header and strike jamb. Single door opening, 3 per strike jamb. Pair door opening, 2 per header.
 2. Exterior and Fire-Rated Frames: Weatherstripping and smoke gasket material to seal opening. Material shall compress to 1/16 inch (2 mm). Ultra WS176, Pemko S88 and Pemko S44 shall be minimum acceptable standard.
- G. Weatherstripping and Smoke Gasketing (Kerf Profile):
 1. Interior Frames: Kerf weatherstrip to seal opening. Schlegel QDS500 is acceptable.
 2. Exterior Frames: Kerf weatherstrip to seal opening. Schlegel QDS500 is acceptable.
- H. Fasteners: In accordance with manufacturer's standards, to comply with labeling agency for fire-rated frames.
 1. Fastener shall be a minimum of 1/2 inch (12.7 mm) longer than combined thickness of drywall.
 - a. Fastener: 1-1/4 inches (32 mm) minimum Type "S" bugle-head self-tapping screws.
 - b. Fastener: 1-1/4 inches (32 mm) minimum drywall screws (coarse thread).
- I. Paint: Frame manufacturer's standard baked-on synthetic enamel, applied over a cleaned and phosphate coated surface.
 1. Application shall be by electrostatic method.

2. Finish paint dry film thickness on doors panels shall be approximately 1 mil (0.03 mm) for finished paint.
3. Factory finish paint shall pass 200 hour salt spray test in accordance with ASTM B117 and 700 hour humidity test in accordance with ASTM D1735 with no blistering.
4. Paint hardness shall meet calibrated pencil lead test to ASTM D3363.
5. Prime painted frames shall be field painted within 30 days of installation with a good quality oil based enamel as recommended, or a high quality water base latex. A flash rust inhibitor shall be used with water base latex method.

PART 3 EXECUTION

3.0 MANUFACTURER'S INSTRUCTIONS

- A. Compliance: Comply with manufacturer's product data, including product technical bulletins, product catalog installation instructions and product carton instructions for installation.

3.1 EXAMINATION

- A. Site Verification of Conditions: Verify that conditions of substrates previously installed under other sections are acceptable for product installation in accordance with manufacturer's instructions.
- B. Do not begin installation until substrates have been properly prepared.
- C. If substrate preparation is the responsibility of another installer, notify Architect of unsatisfactory preparation before proceeding.

3.2 INSTALLATION

- A. Prefinished Steel Door Frames:
 1. Install frames plumb and square, in accordance with shop drawings and manufacturer's instructions. Verify opening and dimensions with shop drawings. Use door as a template to ensure proper alignment and clearances.
 2. Attach hinges and hang door in frame. Adjust frame to door for equal and uniform clearance between top and sides of door and frame.
 3. Secure frame to wall with the appropriate type fasteners.
 4. Install silencers on interior door frames.
 5. Install weatherstripping on exterior door frames.
 6. Adjust strike plate to hold door tight to stops when closed.
 7. Install smoke gaskets as required.
 8. Install fire-rated door frames in accordance with NFPA 80.

3.3 CLEANING

- A. Cleaning: Remove temporary coverings and protection of adjacent work areas. Repair or replace damaged installed products. Clean installed products in accordance with manufacturer's instructions prior to Owner's acceptance. Remove construction debris from project site and legally dispose of debris.

3.4 PROTECTION

- A. Protection: Protect installed product and finish surfaces from damage during construction.
 1. Repair or replace damaged or defective frames.
 2. Touch up damaged areas of factory-applied finishes with aerosol spray cans of same paint as used in factory.

END OF SECTION

SECTION 8210

WOOD DOORS

1.0 GENERAL

1.01 RELATED WORK SPECIFIED ELSEWHERE

Finish Carpentry	Section 6200
Hardware	Section 8700
Finish of Doors	Section 9800

1.02 DELIVERY, STORAGE AND HANDLING

1.02.1 Delivery and Storage. Do not deliver wood doors until the building is sufficiently dry so that doors will not be damaged by excessive changes in moisture content. Identify each door as to type and location. Upon delivery, finish doors scheduled to receive finish as specified in Section 9800.

1.03 SUBMITTALS

1.03.1 Submit shop drawings to the Architect in accord with the General Conditions and General Requirements. Shop drawings shall show quantities, types, and locations. Door and frame construction shall be fully detailed showing weights of material, finish, framing, reinforcing, method of making joints and cutouts, and must indicate conformance with specified technical requirements.

1.04 QUALITY ASSURANCE

1.04.1 All doors shall carry a lifetime guarantee. Guarantee shall be independent of any specific environmental controls or requirements. Any door which shows warping, bowing, cupping, twisting or delamination of wood veneers within one year from date of substantial completion shall be removed, replaced and refinished, as directed by the Architect at no cost to the Owner. Any doors which show evidence of similar failure after that time shall be covered by the manufacturer's warranty. Furnish written guarantee as per NWMA Standards for all doors.

2.0 PRODUCTS

2.01 WOOD DOORS

2.01.1 All wood doors shall be constructed in accordance with NWMA Standards, and shall bear the NWMA seal of approval.

2.01.2 Wood doors shall be as manufactured by Masonite. Similar products as manufactured by V.T. Industries and Graham Manufacturing are also acceptable, subject to compliance with this specification.

2.01.3 Wood doors shall be flush wood doors of the sizes and thickness as indicated on the drawings. Doors shall be primed to receive paint finish.

2.01.4 Provide labeled fire doors of sizes, types, thickness and fire ratings as indicated on the drawings.

3.0 EXECUTION

3.01 HANGING OF WOOD DOORS

3.01.1 Fit wood doors to provide 1/16 inch to 1/8 inch clearance at all four edges, except clearances shall be 1/2 inch at door bottoms. After fitting, install wood doors. Do not cut doors down from a larger size to fit a smaller opening. Prepare doors for installation of hardware items to produce the best possible operation and durability.

3.02 FINISH OF DOORS

3.02.1 Doors shall be painted as specified in Section 9800.

SECTION 8572

FIBERGLASS COMPOSITE WINDOWS

1.0 GENERAL

1.01 RELATED WORK SPECIFIED ELSEWHERE

Sealants	Section 7900
Glazing	Section 8800

1.02 SUBMITTALS

1.02.1 Submit shop drawings to the Architect in accordance with the General Conditions and General Requirements.

1.03 PERFORMANCE REQUIREMENTS

1.03.1 Window Air Leakage, ASTM E 283: Window air leakage when tested at 1.57 psf (25 mph) shall be 0.25 cfm/ft² of frame or less. Window Water Penetration, ASTM E 547: No water penetration through window when tested under static pressure of 4.5 psf (42 mph) after 4 cycles of 5 minutes each, with water being applied at a rate of 5 gallons per hour per square foot.

1.04 DELIVERY, STORAGE, AND HANDLING

1.04.1 Deliver materials to site undamaged in manufacturer's original, unopened containers and packaging, with labels clearly identifying manufacturer and product name. Include installation instructions. Store materials in accordance with manufacturer's instructions, off ground and under cover. Protect materials from weather, direct sunlight, and construction activities. Protect materials and finish during handling and installation to prevent damage.

2.0 PRODUCTS

2.01 WOOD CLAD WINDOWS

2.01.1 Fiberglass composite windows shall be "Impervia" as manufactured by Pella Corporation, factory assembled fixed frame windows. Frame material shall be Duracast, 5 layer, pultruded-fiberglass material, reinforced with interlocking mat. Overall frame dimension shall be 3 inches, and nominal wall thickness of fiberglass members shall be 0.050 to 0.080 inches. Frame corners shall be mitered, joined and bonded with thermoset polyurethane adhesive, nylon corner lock and mechanically fastened. Provide nailing fin for installation. Color of windows shall be brown.

2.01.2 "Integrity" fiberglass windows as manufactured by Marvin Windows are also, subject to full compliance with the product specified.

2.01.3 Glass shall be manufacturer's standard insulating glass, with low E and shall be argon filled for all windows except window type A2, which shall be Insulated, SunDefense low-e, Laminated, Tempered, HurricaneShield glazing.

2.01.4 Provide Pella SmartFlash Flashing/Sealant Tape, aluminum-foil-backed butyl window and door flashing tape, maximum Total Thickness: 0.013 inch, UV resistant.

2.01.5 Wood jamb extensions shall be provided by the general contractor as indicated on the drawings.

3.0 EXECUTION

3.01 INSTALLATION OF WINDOWS

3.01.1 Install windows in accordance with manufacturer's instructions, and to be weather-tight. Maintain alignment with adjacent work. Secure assembly to framed openings, plumb and square, without distortion.

3.01.2 Integrate window system installation with exterior water-resistant barrier using flashing/sealant tape. Apply and integrate flashing/sealant tape with water-resistant barrier using watershed principles in accordance with window manufacturer's instructions.

3.02 CLEANING AND PROTECTION

3.02.1 Clean window frames and glass in accordance with Division 1 requirements. Do not use harsh cleaning materials or methods that would damage finish or glass. Remove labels and visible markings.

3.02.2 Protect installed windows to ensure that, except for normal weathering, windows will be without damage or deterioration at time of substantial completion.

SECTION 8700

DOOR HARDWARE

PART 1 - GENERAL

1.01 SUMMARY

A. Section includes:

1. Mechanical and electrified door hardware
2. Electronic access control system components
3. Field verification, preparation and modification of existing doors and frames to receive new door hardware.

B. Section excludes:

1. Windows
2. Cabinets (casework), including locks in cabinets.
3. Signage
4. Toilet accessories
5. Overhead doors

C. Related Sections:

1. Division 01 Section "Alternates" for alternates affecting this section.
2. Division 08 Sections:
 - a. "Metal Doors and Frames", pre-finished frames (Redi Frame)
 - b. "Flush Wood Doors"
3. Division 26 "Electrical" sections for connections to electrical power system and for low-voltage wiring.

1.02 REFERENCES

A. UL, LLC

1. UL 10B - Fire Test of Door Assemblies
2. UL 10C - Positive Pressure Test of Fire Door Assemblies
3. UL 1784 - Air Leakage Tests of Door Assemblies
4. UL 305 - Panic Hardware

B. DHI - Door and Hardware Institute

1. Sequence and Format for the Hardware Schedule
2. Recommended Locations for Builders Hardware
3. Keying Systems and Nomenclature
4. Installation Guide for Doors and Hardware

C. NFPA – National Fire Protection Association

1. NFPA 70 – National Electric Code

2. NFPA 80 – 2016 Edition – Standard for Fire Doors and Other Opening Protectives
3. NFPA 101 – Life Safety Code
4. NFPA 105 – Smoke and Draft Control Door Assemblies
5. NFPA 252 – Fire Tests of Door Assemblies

D. ANSI - American National Standards Institute

1. ANSI A117.1 – 2017 Edition – Accessible and Usable Buildings and Facilities
2. ANSI/BHMA A156.1 - A156.29, and ANSI/BHMA A156.31 - Standards for Hardware and Specialties
3. ANSI/BHMA A156.28 - Recommended Practices for Keying Systems
4. ANSI/WDMA I.S. 1A - Interior Architectural Wood Flush Doors
5. ANSI/SDI A250.8 - Standard Steel Doors and Frames

1.03 SUBMITTALS

A. General:

1. Submit in accordance with Conditions of Contract and Division 01 Submittal Procedures.
2. Prior to forwarding submittal:
 - a. Comply with procedures for verifying existing door and frame compatibility for new hardware, as specified in PART 3, "EXAMINATION" article, herein.
 - b. Review drawings and Sections from related trades to verify compatibility with specified hardware.
 - c. Highlight, encircle, or otherwise specifically identify on submittals: deviations from Contract Documents, issues of incompatibility or other issues which may detrimentally affect the Work.

B. Action Submittals:

1. Product Data: Submit technical product data for each item of door hardware, installation instructions, maintenance of operating parts and finish, and other information necessary to show compliance with requirements.
2. Door Hardware Schedule:
 - a. Submit concurrent with submissions of Product Data, Samples, and Shop Drawings. Coordinate submission of door hardware schedule with scheduling requirements of other work to facilitate fabrication of other work critical in Project construction schedule.
 - b. Indicate complete designations of each item required for each opening, include:
 - 1) Door Index: door number, heading number, and Architect's hardware set number.
 - 2) Quantity, type, style, function, size, and finish of each hardware item.
 - 3) Name and manufacturer of each item.
 - 4) Fastenings and other pertinent information.
 - 5) Location of each hardware set cross-referenced to indications on Drawings.
 - 6) Explanation of all abbreviations, symbols, and codes contained in schedule.
 - 7) Mounting locations for hardware.
 - 8) Door and frame sizes and materials.
 - 9) Degree of door swing and handing.
 - 10) Operational Description of openings with electrified hardware covering egress, ingress (access), and fire/smoke alarm connections.

C. Informational Submittals:

1. Provide Qualification Data for Supplier, Installer and Architectural Hardware Consultant.
2. Provide Product Data:
 - a. Certify that door hardware approved for use on types and sizes of labeled fire-rated doors complies with listed fire-rated door assemblies.
 - b. Include warranties for specified door hardware.

D. Closeout Submittals:

1. Operations and Maintenance Data: Provide in accordance with Division 01 and include:
 - a. Complete information on care, maintenance, and adjustment; data on repair and replacement parts, and information on preservation of finishes.
 - b. Catalog pages for each product.
 - c. Final approved hardware schedule edited to reflect conditions as installed.
 - d. Final keying schedule
 - e. Copy of warranties including appropriate reference numbers for manufacturers to identify project.
 - f. As-installed wiring diagrams for each opening connected to power, both low voltage and 110 volts.

1.04 QUALITY ASSURANCE

A. Qualifications and Responsibilities:

1. Supplier: Recognized architectural hardware supplier with a minimum of 5 years documented experience supplying both mechanical and electromechanical door hardware similar in quantity, type, and quality to that indicated for this Project. Supplier to be recognized as a factory direct distributor by the manufacturer of the primary materials with a warehousing facility in the Project's vicinity. Supplier to have on staff, a certified Architectural Hardware Consultant (AHC) or Door Hardware Consultant (DHC) available to Owner, Architect, and Contractor, at reasonable times during the Work for consultation.
2. Installer: Qualified tradesperson skilled in the application of commercial grade hardware with experience installing door hardware similar in quantity, type, and quality as indicated for this Project.
3. Single Source Responsibility: Obtain each type of door hardware from single manufacturer.

B. Certifications:

1. Fire-Rated Door Openings:
 - a. Provide door hardware for fire-rated openings that complies with NFPA 80 and requirements of authorities having jurisdiction.
 - b. Provide only items of door hardware that are listed products tested by UL LLC, Intertek Testing Services, or other testing and inspecting organizations acceptable to authorities having jurisdiction for use on types and sizes of doors indicated, based on testing at positive pressure and according to NFPA 252 or UL 10C and in compliance with requirements of fire-rated door and door frame labels.
2. Smoke and Draft Control Door Assemblies:
 - a. Provide door hardware that meets requirements of assemblies tested according to UL 1784 and installed in compliance with NFPA 105

- b. Comply with the maximum air leakage of 0.3 cfm/sq. ft. (3 cu. m per minute/sq. m) at tested pressure differential of 0.3-inch wg (75 Pa) of water.

3. Accessibility Requirements:

- a. Comply with governing accessibility regulations cited in "REFERENCES" article 087100, 1.02.D3 herein for door hardware on doors in an accessible route. This project must comply with all Federal Americans with Disability Act regulations and all Local Accessibility Regulations.

C. Pre-Installation Meetings

1. Keying Conference

- a. Incorporate keying conference decisions into final keying schedule after reviewing door hardware keying system including:
 - 1) Function of building, flow of traffic, purpose of each area, degree of security required, and plans for future expansion.
 - 2) Preliminary key system schematic diagram.
 - 3) Requirements for key control system.
 - 4) Requirements for access control.
 - 5) Address for delivery of keys.

2. Pre-installation Conference

- a. Review and finalize construction schedule and verify availability of materials, Installer's personnel, equipment, and facilities needed to make progress and avoid delays.
- b. Inspect and discuss preparatory work performed by other trades.
- c. Inspect and discuss electrical roughing-in for electrified door hardware.
- d. Review sequence of operation for each type of electrified door hardware.
- e. Review required testing, inspecting, and certifying procedures.
- f. Review questions or concerns related to proper installation and adjustment of door hardware.

3. Electrified Hardware Coordination Conference:

- a. Prior to ordering electrified hardware, schedule and hold meeting to coordinate door hardware with security, electrical, doors and frames, and other related suppliers.

1.05 DELIVERY, STORAGE, AND HANDLING

- A. Inventory door hardware on receipt and provide secure lock-up for hardware delivered to Project site. Promptly replace products damaged during shipping.
- B. Tag each item or package separately with identification coordinated with final door hardware schedule, and include installation instructions, templates, and necessary fasteners with each item or package. Deliver each article of hardware in manufacturer's original packaging.
- C. Maintain manufacturer-recommended environmental conditions throughout storage and installation periods.
- D. Provide secure lock-up for door hardware delivered to Project. Control handling and installation of hardware items so that completion of Work will not be delayed by hardware losses both before and after installation.

- E. Handle hardware in manner to avoid damage, marring, or scratching. Correct, replace or repair products damaged during Work. Protect products against malfunction due to paint, solvent, cleanser, or any chemical agent.
- F. Deliver keys to manufacturer of key control system for subsequent delivery to Owner.

1.06 COORDINATION

- A. Coordinate layout and installation of floor-recessed door hardware with floor construction. Cast anchoring inserts into concrete.
- B. Installation Templates: Distribute for doors, frames, and other work specified to be factory or shop prepared. Check Shop Drawings of other work to confirm that adequate provisions are made for locating and installing door hardware to comply with indicated requirements.
- C. Security: Coordinate installation of door hardware, keying, and access control with Owner's security consultant.
- D. Existing Openings: Where existing doors, frames and/or hardware are to remain, field verify existing functions, conditions and preparations and coordinate to suit opening conditions and to provide proper door operation.

1.07 WARRANTY

- A. Manufacturer's standard form in which manufacturer agrees to repair or replace components of door hardware that fail in materials or workmanship within published warranty period.
 - 1. Warranty does not cover damage or faulty operation due to improper installation, improper use or abuse.
 - 2. Warranty Period: Beginning from date of Substantial Completion, for durations indicated in manufacturer's published listings.
 - a. Mechanical Warranty
 - 1) Locks
 - a) Schlage ND Series: 10 years
 - 2) Exit Devices
 - a) Von Duprin: 3 years
 - 3) Closers
 - a) LCN 4000 Series: 30 years

1.08 MAINTENANCE

- A. Furnish complete set of special tools required for maintenance and adjustment of hardware, including changing of cylinders.
- B. Turn over unused materials to Owner for maintenance purposes.

PART 2 - PRODUCTS

2.01 MANUFACTURERS

- A. The Owner requires use of certain products for their unique characteristics and project suitability to ensure continuity of existing and future performance and maintenance standards. After investigating available product offerings, the Awarding Authority has elected to prepare proprietary specifications. These products are specified with the notation: "No Substitute."
 - 1. Where "No Substitute" is noted, submittals and substitution requests for other products will not be considered.
- B. Approval of alternate manufacturers and/or products other than those listed as "Scheduled Manufacturer" or "Acceptable Manufacturers" in the individual article for the product category are only to be considered by official substitution request in accordance with section 01 25 00.

2.02 MATERIALS

- A. Fabrication
 - 1. Provide door hardware manufactured to comply with published templates generally prepared for machine, wood, and sheet metal screws. provide screws according to manufacturer's recognized installation standards for application intended.
 - 2. Finish exposed screws to match hardware finish, or, if exposed in surfaces of other work, to match finish of this other work including prepared for paint surfaces to receive painted finish.
 - 3. Provide concealed fasteners wherever possible for hardware units exposed when door is closed. Coordinate with "Metal Doors and Frames", "Flush Wood Doors", "Stile and Rail Wood Doors" to ensure proper reinforcements. Advise the Architect where visible fasteners, such as thru bolts, are required.
- B. Provide screws, bolts, expansion shields, drop plates and other devices necessary for hardware installation.
 - 1. Where fasteners are exposed to view: Finish to match adjacent door hardware material.

2.03 HINGES

- A. Manufacturers and Products:
 - 1. Scheduled Manufacturer and Product:
 - a. Ives 5BB series
 - 2. Acceptable Manufacturers and Products:
 - a. Hager BB1191/1279 series
- B. Requirements:
 - 1. Provide hinges conforming to ANSI/BHMA A156.1.
 - 2. Provide five knuckles, ball bearing hinges.

3. 1-3/4 inch (44 mm) thick doors, up to and including 36 inches (914 mm) wide:
 - a. Exterior: Standard weight, bronze or stainless steel, 4-1/2 inches (114 mm) high
 - b. Interior: Standard weight, steel, 4-1/2 inches (114 mm) high
4. 1-3/4 inch (44 mm) thick doors over 36 inches (914 mm) wide:
 - a. Exterior: Heavy weight, bronze/stainless steel, 5 inches (127 mm) high
 - b. Interior: Heavy weight, steel, 5 inches (127 mm) high
5. Adjust hinge width for door, frame, and wall conditions to allow proper degree of opening.
6. Provide three hinges per door leaf for doors 90 inches (2286 mm) or less in height, and one additional hinge for each 30 inches (762 mm) of additional door height.
7. Where new hinges are specified for existing doors or existing frames, provide new hinges of identical size to hinge preparation present in existing door or existing frame.
8. Hinge Pins: Except as otherwise indicated, provide hinge pins as follows:
 - a. Steel Hinges: Steel pins
 - b. Non-Ferrous Hinges: Stainless steel pins
 - c. Out-Swinging Exterior Doors: Non-removable pins
 - d. Out-Swinging Interior Lockable Doors: Non-removable pins
 - e. Interior Non-lockable Doors: Non-rising pins

2.04 SURFACE BOLTS

A. Manufacturers:

1. Scheduled Manufacturer:
 - a. Ives
2. Acceptable Manufacturers:
 - a. Burns
 - b. Rockwood

B. Requirements:

1. Surface bolts to have 1" throw for maximum security with concealed mounting that prevents vandalism. Units to be constructed of heavy-duty steel and UL listed up to three (3) hours when used on the inactive door of a pair up to 8' in height.

2.05 CYLINDRICAL LOCKS – GRADE 1

A. Manufacturers and Products:

1. Scheduled Manufacturer and Product:
 - a. Schlage ND series with BD configuration
2. Acceptable Manufacturers:
 - a. Best 9K3 series

B. Requirements:

1. Provide cylindrical locks conforming to ANSI/BHMA A156.2 Series 4000, Grade 1, and UL Listed for 3-hour fire doors.
2. Cylinders: Refer to "KEYING" article, herein.
3. Provide locks with standard 2-3/4 inches (70 mm) backset, unless noted otherwise, with 1/2-inch latch throw. Provide proper latch throw for UL listing at pairs.
4. Provide locksets with separate anti-rotation thru-bolts, and no exposed screws.
5. Provide independently operating levers with two external return spring cassettes mounted under roses to prevent lever sag.
6. Provide standard ASA strikes unless extended lip strikes are necessary to protect trim.
7. Provide electrified options as scheduled in the hardware sets.
8. Lever Trim: Solid cast levers without plastic inserts and wrought roses on both sides.
 - a. Lever Design: RHODES (RHO).

2.06 EXIT DEVICES

A. Manufacturers and Products:

1. Scheduled Manufacturer and Product:
 - a. Von Duprin 99 series

B. Requirements:

1. Provide exit devices tested to ANSI/BHMA A156.3 Grade 1 and UL listed for Panic Exit or Fire Exit Hardware.
2. Cylinders: Refer to "KEYING" article, herein.
3. Provide grooved touchpad type exit devices, fabricated of brass, bronze, stainless steel, or aluminum, plated to standard architectural finishes to match balance of door hardware.
4. Touchpad must extend a minimum of one half of door width. No plastic inserts are allowed in touchpads.
5. Provide exit devices with deadlatching feature for security and for future addition of alarm kits and/or other electrified requirements.
6. Provide exit devices with weather resistant components that can withstand harsh conditions of various climates and corrosive cleaners used in outdoor pool environments.
7. Provide flush end caps for exit devices.
8. Provide exit devices with manufacturer's approved strikes.
9. Provide exit devices cut to door width and height. Install exit devices at height recommended by exit device manufacturer, allowable by governing building codes, and approved by Architect.
10. Mount mechanism case flush on face of doors or provide spacers to fill gaps behind devices. Where glass trim or molding projects off face of door, provide glass bead kits.
11. Provide cylinder or hex-key dogging as specified at non-fire-rated openings.
12. Removable Mullions: 2 inches (51 mm) x 3 inches (76 mm) steel tube. Where scheduled as keyed removable mullion, provide type that can be removed by use of a keyed cylinder, which is self-locking when re-installed.
13. Provide factory drilled weep holes for exit devices used in full exterior application, highly corrosive areas, and were noted in hardware sets.
14. Provide electrified options as scheduled.
15. Top latch mounting: double- or single-tab mount for steel doors, face mount for aluminum doors eliminating requirement of tabs, and double tab mount for wood doors.
16. Provide exit devices with optional trim designs to match other lever and pull designs used on the project.

2.07 CYLINDERS

A. Manufacturers and Products:

1. Scheduled Manufacturer and Product:

- a. Best cores

B. Requirements:

1. Provide cylinders/cores compliant with ANSI/BHMA A156.5; latest revision; cylinder face finished to match lockset; manufacturer's series as indicated. Refer to "KEYING" article, herein.
2. Provide cylinders in the below-listed configuration(s), distributed throughout the Project as indicated.
 - a. Patented Open: cylinder with interchangeable core with open keyway.
3. Patent Protection: Cylinders/cores requiring use of restricted, patented keys, patent protected.
4. Nickel silver bottom pins.

2.08 DOOR CLOSERS

A. Manufacturers and Products:

1. Scheduled Manufacturer and Product:

- a. LCN 4040XP series

B. Requirements:

1. Provide door closers conforming to ANSI/BHMA A156.4 Grade 1 requirements by BHMA certified independent testing laboratory. ISO 9000 certify closers. Stamp units with date of manufacture code.
2. Provide door closers with fully hydraulic, full rack and pinion action with high strength cast iron cylinder, and full complement bearings at shaft.
3. Cylinder Body: 1-1/2-inch (38 mm) diameter piston with 5/8-inch (16 mm) diameter double heat-treated pinion journal. QR code with a direct link to maintenance instructions.
4. Hydraulic Fluid: Fireproof, passing requirements of UL10C, and requiring no seasonal closer adjustment for temperatures ranging from 120 degrees F to -30 degrees F.
5. Spring Power: Continuously adjustable over full range of closer sizes, and providing reduced opening force as required by accessibility codes and standards. Provide Snap-On cover clip, with plastic covers, which secures cover to spring tube.
6. Hydraulic Regulation: By tamper-proof, non-critical valves, with separate adjustment for latch speed, general speed, and backcheck. Provide graphically labelled instructions on the closer body adjacent to each adjustment valve. Provide positive stop on reg valve that prevents reg screw from being backed out.
7. Provide closers with solid forged steel main arms and factory assembled heavy-duty forged forearms for parallel arm closers.
8. Pressure Relief Valve (PRV) Technology: Not permitted.
9. Finish for Closer Cylinders, Arms, Adapter Plates, and Metal Covers: Powder coating finish which has been certified to exceed 100 hours salt spray testing as described in ANSI Standard A156.4 and ASTM B117 or has special rust inhibitor (SRI).

10. Provide special templates, drop plates, mounting brackets, or adapters for arms as required for details, overhead stops, and other door hardware items interfering with closer mounting.

2.09 DOOR TRIM

A. Manufacturers:

1. Scheduled Manufacturer:
 - a. Ives.
2. Acceptable Manufacturers:
 - a. Burns
 - b. Rockwood

B. Requirements:

1. Provide push plates, push bars, pull plates, pulls, and hands-free reversible door pulls with diameter and length as scheduled.

2.10 PROTECTION PLATES

A. Manufacturers:

1. Scheduled Manufacturer:
 - a. Ives
2. Acceptable Manufacturers:
 - a. Burns
 - b. Rockwood

B. Requirements:

1. Provide protection plates with a minimum of 0.050 inch (1 mm) thick, beveled four edges as scheduled. Furnish with sheet metal or wood screws, finished to match plates.
2. Size plates 2 inches (51 mm) less width of door on single doors, pairs of doors with a mullion, and doors with edge guards. Size plates 1 inch (25 mm) less width of door on pairs without a mullion or edge guards.
3. At fire rated doors, provide protection plates over 16 inches high with UL label.

2.11 DOOR STOPS AND HOLDERS

A. Manufacturers:

1. Scheduled Manufacturer:
 - a. Ives
2. Acceptable Manufacturers:

- a. Burns
 - b. Rockwood
- B. Provide door stops at each door leaf:
- 1. Provide wall stops wherever possible. Provide concave type where lockset has a push button of thumbturn.
 - 2. Where a wall stop cannot be used, provide universal floor stops.
 - 3. Where wall or floor stop cannot be used, provide overhead stop.
 - 4. Provide roller bumper where doors open into each other, and overhead stop cannot be used.

2.12 THRESHOLDS, SEALS, DOOR SWEEPS, AUTOMATIC DOOR BOTTOMS, AND GASKETING

A. Manufacturers:

- 1. Scheduled Manufacturer:
 - a. Zero International
- 2. Acceptable Manufacturers:
 - a. National Guard
 - b. Reese

B. Requirements:

- 1. Provide thresholds, weather-stripping, and gasketing systems as specified and per architectural details. Match finish of other items.
- 2. Smoke- and Draft-Control Door Assemblies: Where smoke- and draft-control door assemblies are required, provide door hardware that meets requirements of assemblies tested according to UL 1784 and installed in compliance with NFPA 105.
- 3. Provide door sweeps, seals, astragals, and auto door bottoms only of type where resilient or flexible seal strip is easily replaceable and readily available.
- 4. Size thresholds 1/2 inch (13 mm) high by 5 inches (127 mm) wide by door width unless otherwise specified in the hardware sets or detailed in the drawings.

2.13 FINISHES

A. Finish: BHMA 626/652 (US26D); except:

- 1. Hinges at Exterior Doors: BHMA 630 (US32D)
- 2. Aluminum Geared Continuous Hinges: BHMA 628 (US28)
- 3. Push Plates, Pulls, and Push Bars: BHMA 630 (US32D)
- 4. Protection Plates: BHMA 630 (US32D)
- 5. Overhead Stops and Holders: BHMA 630 (US32D)
- 6. Door Closers: Powder Coat to Match
- 7. Wall Stops: BHMA 630 (US32D)
- 8. Latch Protectors: BHMA 630 (US32D)
- 9. Weatherstripping: Clear Anodized Aluminum
- 10. Thresholds: Mill Finish Aluminum

B. Finish: BHMA 622/631 (US19); except:

- 1. Door Closers: Powder Coat to Match

2. Weatherstripping: Black
 3. Thresholds: Mill Finish Black
- C. Finish: BHMA 630 (US32D); except:
1. Aluminum Geared Continuous Hinges: BHMA 628 (US28)
 2. Door Closers: Powder Coat to Match
 3. Weatherstripping: Clear Anodized Aluminum
 4. Thresholds: Mill Finish Aluminum

PART 3 - EXECUTION

3.01 EXAMINATION

- A. Prior to installation of hardware, examine doors and frames, with Installer present, for compliance with requirements for installation tolerances, labeled fire-rated door assembly construction, wall and floor construction, and other conditions affecting performance. Verify doors, frames, and walls have been properly reinforced for hardware installation.
- B. Field verify existing doors and frames receiving new hardware and existing conditions receiving new openings. Verify that new hardware is compatible with existing door and frame preparation and existing conditions.
- C. Examine roughing-in for electrical power systems to verify actual locations of wiring connections before electrified door hardware installation.
- D. Submit a list of deficiencies in writing and proceed with installation only after unsatisfactory conditions have been corrected.

3.02 PREPARATION

- A. Where on-site modification of doors and frames is required:
 1. Carefully remove existing door hardware and components being reused. Clean, protect, tag, and store in accordance with storage and handling requirements specified herein.
 2. Field modify and prepare existing doors and frames for new hardware being installed.
 3. When modifications are exposed to view, use concealed fasteners, when possible.
 4. Prepare hardware locations and reinstall in accordance with installation requirements for new door hardware and with:
 - a. Steel Doors and Frames: For surface applied door hardware, drill and tap doors and frames according to ANSI/SDI A250.6.
 - b. Wood Doors: DHI WDHS.5 "Recommended Hardware Reinforcement Locations for Mineral Core Wood Flush Doors."
 - c. Doors in rated assemblies: NFPA 80 for restrictions on on-site door hardware preparation.

3.03 INSTALLATION

- A. Mount door hardware units at heights to comply with the following, unless otherwise indicated or required to comply with governing regulations.

1. Standard Steel Doors and Frames: ANSI/SDI A250.8.
 2. Custom Steel Doors and Frames: HMMA 831.
 3. Interior Architectural Wood Flush Doors: ANSI/WDMA I.S. 1A
 4. Installation Guide for Doors and Hardware: DHI TDH-007-20
- B. Install door hardware in accordance with NFPA 80, NFPA 101 and provide post-install inspection, testing as specified in section 1.03.E unless otherwise required to comply with governing regulations.
- C. Install each hardware item in compliance with manufacturer's instructions and recommendations, using only fasteners provided by manufacturer.
- D. Do not install surface mounted items until finishes have been completed on substrate. Protect all installed hardware during painting.
- E. Set units level, plumb and true to line and location. Adjust and reinforce attachment substrate as necessary for proper installation and operation.
- F. Drill and countersink units that are not factory prepared for anchorage fasteners. Space fasteners and anchors according to industry standards.
- G. Install operating parts so they move freely and smoothly without binding, sticking, or excessive clearance.
- H. Hinges: Install types and in quantities indicated in door hardware schedule but not fewer than quantity recommended by manufacturer for application indicated.
- I. Key Control System: Tag keys and place them on markers and hooks in key control system cabinet, as determined by final keying schedule.
- J. Door Closers: Mount closers on room side of corridor doors, inside of exterior doors, and stair side of stairway doors from corridors. Mount closers so they are not visible in corridors, lobbies and other public spaces unless approved by Architect.
- K. Closer/holders: Mount closer/holders on room side of corridor doors, inside of exterior doors, and stair side of stairway doors.
- L. Power Supplies: Locate power supplies as indicated or, if not indicated, above accessible ceilings or in equipment room, or alternate location as directed by Architect.
- M. Thresholds: Set thresholds in full bed of sealant complying with requirements specified in Division 07 Section "Joint Sealants."
- N. Stops: Provide floor stops for doors unless wall or other type stops are indicated in door hardware schedule. Do not mount floor stops where they may impede traffic or present tripping hazard.
- O. Perimeter Gasketing: Apply to head and jamb, forming seal between door and frame.
- P. Meeting Stile Gasketing: Fasten to meeting stiles, forming seal when doors are closed.
- Q. Door Bottoms and Sweeps: Apply to bottom of door, forming seal with threshold when door is closed.

3.04 ADJUSTING

- A. Initial Adjustment: Adjust and check each operating item of door hardware and each door to ensure proper operation or function of every unit. Replace units that cannot be adjusted to operate as intended. Adjust door control devices to compensate for final operation of heating and ventilating equipment and to comply with referenced accessibility requirements.
 - 1. Door Closers: Adjust sweep period to comply with accessibility requirements and requirements of authorities having jurisdiction.
- B. Occupancy Adjustment: Approximately three to six months after date of Substantial Completion, examine and readjust each item of door hardware, including adjusting operating forces, as necessary to ensure function of doors and door hardware.

3.05 CLEANING AND PROTECTION

- A. Clean adjacent surfaces soiled by door hardware installation.
- B. Clean operating items per manufacturer's instructions to restore proper function and finish.
- C. Provide final protection and maintain conditions that ensure door hardware is without damage or deterioration at time of Substantial Completion.

3.06 DOOR HARDWARE SCHEDULE

- A. The intent of the hardware specification is to specify the hardware for interior and exterior doors, and to establish a type, continuity, and standard of quality. However, it is the door hardware supplier's responsibility to thoroughly review existing conditions, schedules, specifications, drawings, and other Contract Documents to verify the suitability of the hardware specified.
- B. Discrepancies, conflicting hardware, and missing items are to be brought to the attention of the architect with corrections made prior to the bidding process. Omitted items not included in a hardware set should be scheduled with the appropriate additional hardware required for proper application.
- C. Hardware items are referenced in the following hardware schedule. Refer to the above specifications for special features, options, cylinders/keying, and other requirements.
- D. Hardware Sets:

Hardware Group No. 01

For use on Door #(s):

101A 101C

Provide each SGL door(s) with the following:

QTY		DESCRIPTION	CATALOG NUMBER	ITEMID	FINISH	MFR
3	EA	HEAVY WEIGHT HINGE	5BB1HW NRP		626	IVE
1	EA	PANIC HARDWARE	99-NL		626	VON
1	EA	SFIC RIM CYLINDER	80-116 DISPOSABLE CORE		626	SCH
1	EA	SFIC CORE	BEST		626	BES
1	EA	SURFACE CLOSER	4040XP HEDA		689	LCN
1	EA	KICK PLATE	8400 10" X 2" LDW B-CS		630	IVE
1	EA	WALL STOP	WS406/407CCV		630	IVE
1	EA	GASKETING	429AA-S		AA	ZER
1	EA	DOOR SWEEP	39A		A	ZER
1	EA	THRESHOLD	655A-223		A	ZER

INSTALL GASKETING PRIOR TO ALL OTHER HARDWARE.

Hardware Group No. 01A

For use on Door #(s):

113

Provide each SGL door(s) with the following:

QTY		DESCRIPTION	CATALOG NUMBER	ITEMID	FINISH	MFR
3	EA	HEAVY WEIGHT HINGE	5BB1HW NRP		626	IVE
1	EA	PANIC HARDWARE	99-NL		626	VON
1	EA	SFIC RIM CYLINDER	80-116 DISPOSABLE CORE		626	SCH
1	EA	SFIC CORE	BEST		626	BES
1	EA	FSIC RIM CYLINDER	20-057		626	SCH
1	EA	SURFACE CLOSER	4040XP HEDA		689	LCN
1	EA	KICK PLATE	8400 10" X 2" LDW B-CS		630	IVE
1	EA	WALL STOP	WS406/407CCV		630	IVE
1	EA	DOOR SWEEP	39A		A	ZER
1	EA	THRESHOLD	655A-223		A	ZER

Hardware Group No. 01B

For use on Door #(s):

101B 101D

Provide each SGL door(s) with the following:

QTY		DESCRIPTION	CATALOG NUMBER	ITEMID	FINISH	MFR
3	EA	HEAVY WEIGHT HINGE	5BB1HW NRP		626	IVE
1	EA	PANIC HARDWARE	99-EO		626	VON
1	EA	SURFACE CLOSER	4040XP HEDA		689	LCN
1	EA	KICK PLATE	8400 10" X 2" LDW B-CS		630	IVE
1	EA	WALL STOP	WS406/407CCV		630	IVE
1	EA	GASKETING	429AA-S		AA	ZER
1	EA	DOOR SWEEP	39A		A	ZER
1	EA	THRESHOLD	655A-223		A	ZER

INSTALL GASKETING PRIOR TO ALL OTHER HARDWARE.

Hardware Group No. 02

For use on Door #(s):

112

Provide each PR door(s) with the following:

QTY		DESCRIPTION	CATALOG NUMBER	ITEMID	FINISH	MFR
6	EA	HEAVY WEIGHT HINGE	5BB1HW NRP		626	IVE
2	EA	SURFACE BOLT	SB360-12" T&B		604	IVE
1	EA	STOREROOM LOCK	ND80BD RHO LLL LESS STRIKE		626	SCH
1	EA	SFIC CORE	BEST		626	BES
1	EA	STRIKE	XQ07-351 7/8" FLAT LIP		626	SCH
2	EA	KICK PLATE	8400 10" X 1" LDW B-CS		630	IVE
1	EA	RAIN DRIP	142AA		AA	ZER
1	EA	GASKETING	429AA-S		AA	ZER
2	SET	MEETING STILE	8193AA (2 PCS - 1 SET)		AA	ZER
2	EA	DOOR SWEEP	39A		A	ZER
1	EA	THRESHOLD	655A-223		A	ZER

INSTALL GSKETING PRIR TO ALL OTHER HARDWARE.

Hardware Group No. 03

For use on Door #(s):

102 109

Provide each SGL door(s) with the following:

QTY		DESCRIPTION	CATALOG NUMBER	ITEMID	FINISH	MFR
3	EA	HEAVY WEIGHT HINGE	5BB1HW		626	IVE
1	EA	CLASSROOM LOCK	ND70BD RHO		626	SCH
1	EA	SFIC CORE	BEST		626	BES
1	EA	SURFACE CLOSER	4040XP REG		689	LCN
1	EA	KICK PLATE	8400 10" X 2" LDW B-CS		630	IVE
1	EA	WALL STOP	WS406/407CCV		630	IVE
1	EA	RAIN DRIP	142AA		AA	ZER
1	EA	GASKETING	429AA-S		AA	ZER
1	EA	DOOR SWEEP	39A		A	ZER
1	EA	THRESHOLD	655A-223		A	ZER

Hardware Group No. 04

For use on Door #(s):

106

Provide each SGL door(s) with the following:

QTY		DESCRIPTION	CATALOG NUMBER	ITEMID	FINISH	MFR
3	EA	STANDARD WEIGHT HINGE	5BB1 NRP		652	IVE
1	EA	STOREROOM LOCK	ND80BD RHO		626	SCH
1	EA	SFIC CORE	BEST		626	BES
1	EA	SURFACE CLOSER	4040XP SCUSH		689	LCN
1	EA	KICK PLATE	8400 10" X 2" LDW B-CS		630	IVE
1	EA	WALL STOP	WS406/407CCV		630	IVE

Hardware Group No. 05

For use on Door #(s):

104

Provide each SGL door(s) with the following:

QTY		DESCRIPTION	CATALOG NUMBER	ITEMID	FINISH	MFR
3	EA	STANDARD WEIGHT HINGE	5BB1		652	IVE
1	EA	CLASSROOM LOCK	ND70BD RHO		626	SCH
1	EA	SFIC CORE	BEST		626	BES
1	EA	SURFACE CLOSER	4040XP REG		689	LCN
1	EA	KICK PLATE	8400 10" X 2" LDW B-CS		630	IVE
1	EA	WALL STOP	WS406/407CCV		630	IVE

Hardware Group No. 06

For use on Door #(s):

103

105

Provide each SGL door(s) with the following:

QTY		DESCRIPTION	CATALOG NUMBER	ITEMID	FINISH	MFR
3	EA	STANDARD WEIGHT HINGE	5BB1		652	IVE
1	EA	PUSH PLATE	8200 4" X 16"		630	IVE
1	EA	PULL PLATE	8303 10" 4" X 16"		630	IVE
1	EA	SURFACE CLOSER	4040XP REG		689	LCN
1	EA	KICK PLATE	8400 10" X 2" LDW B-CS		630	IVE
1	EA	WALL STOP	WS406/407CCV		630	IVE

Hardware Group No. 07 - PELLA DOOR SYSTEM

For use on Door #(s):

201

Provide each SGL door(s) with the following:

QTY		DESCRIPTION	CATALOG NUMBER	ITEMID	FINISH	MFR
ALL HARDWRE PROVIDED BY DOOR MANUFACTURE						

SECTION 8800

GLAZING

1.0 GENERAL

1.01 QUALITY ASSURANCE

1.01.1 Glass shall meet the requirements of Federal Standard No. 123. Material containing bubbles, scratches, or other glass shall be removed immediately upon notice. Each piece of glass shall bear the manufacturer's label.

1.01.2 Coordination. The Glazing Subcontractor shall coordinate his requirements with the Frame Subcontractor to assure that frames are provided with required bite, edge, and face clearance.

1.02 STORAGE AND HANDLING

1.02.1 Stack glazing sheets at five degrees to seven degrees from vertical. Separate sheets with interleaving of protection paper and cushion top and bottom edges with felt. Cover to protect material from windblown water or runoff but provide for ventilation and circulation of cool, dry air. Maintain temperature above dew point. Protect glazing material from welding, sandblasting, and other potentially damaging operations.

1.02.2 Handle glazing sheets to prevent damage to edges and corners.

1.03 JOB CONDITIONS

1.03.1 Temperature shall be 40 degrees Fahrenheit or higher during installation and setting and curing of the glazing compound.

2.0 PRODUCTS

2.01 GLASS

2.01.1 Insulating glass shall be two sheets of 3/16" thick float or plate glass in a sealed insulating panel with total thickness of 1 inch. Provide tempered insulating glass where required by code.

2.01.2 Glass for fiberglass composite windows shall be as specified in Section 8572, and shall be furnished and installed by window manufacturer.

2.02 GLAZING ACCESSORIES

2.02.1 Glazing sealant compound and tape shall be of the type and manufacture recommended by the glazing manufacturer and recommended by the sealant manufacturer for the type of glass and application.

2.02.2 Setting blocks, spacers and fillers shall be neoprene of Shore A durometer hardness and size recommended by the glazing manufacturer. Lead setting blocks may be used when recommended by the glazing manufacturer.

3.0 EXECUTION

3.01 PREPARATION

3.01.1 Field measure frames to determine actual sizes for glazing materials.

3.02 INSTALLATION

3.02.1 Install glass glazing sheets, together with miscellaneous glazing accessories to meet the recommendations of the Glazing Manual for Flat Glass Products of the Flat Glass Marketing Association except the manufacturer's recommendations shall prevail when they differ from the Glazing Manual.

3.03 CLEANING AND PROTECTION

3.03.1 Remove labels from glass immediately after installation.

3.03.2 Clean glass with a soft, clean, gritfree cloth and mild soap, detergent, or slightly acidic cleaning solution. Immediately rinse with clean water and remove excess rinse water with a clean squeegee. Do not use an abrasive cleaner.

3.03.3 Remove grease and miscellaneous glazing materials with commercial solvent. Follow with normal wash and rinse. Be careful not to damage glazing or seals.

3.03.4 Protect glass from breakage by applying crossed streamers to framing, away from glass. Do not apply markers or signs of any type to surface of glazing.

SECTION 9250

GYPSUM DRYWALL

1.0 GENERAL

1.01 RELATED WORK SPECIFIED ELSEWHERE

Rough Carpentry	Section 6100
Painting	Section 9800

1.02 DELIVERY, STORAGE AND HANDLING

1.02.1 Delivery. Do not deliver gypsum drywall to the project site until immediately before application begins.

1.02.2 Storage. Store gypsum drywall under cover and stack on a clean floor in the center of large rooms. Leave materials in their wrappings or containers until ready for actual use. Store accessories flat and protect them from damage and bending.

1.03 JOB CONDITIONS

1.03.1 Temperature and Humidity. When outside temperatures are below 55F, maintain the inside temperature in the range of 55F to 70F for 24 hours before application of gypsum drywall until the project is complete. Provide ventilation to eliminate excess moisture.

1.04 SUBMITTALS

1.04.1 Submit shop drawings for all gypsum drywall materials, including all accessories.

2.0 PRODUCTS

2.01 GYPSUM DRYWALL

2.01.1 Gypsum board shall be 5/8 inch thick Fire Code Gypsum Board with edges tapered for taping, and shall be as manufactured by one of the following:

Celotex	Flintkote
Georgia-Pacific	National Gypsum Co.
United States Gypsum	American Gypsum

2.02 JOINT TREATMENT

2.02.1 Joint reinforcing tape and compounds shall be the type recommended for the application indicated, and shall be of the same manufacture as the wall board, and shall be perforated paper joint tape.

2.02.2 Joint compounds shall be ready mixed vinyl or powder types, one type for bedding tapes and filling depressions, and one type for topping and sanding.

2.03 ACCESSORIES

2.03.1 Accessories shall be galvanized steel headed units with flanges for concealment in joint compound, sizes as recommended for the application indicated, except as otherwise indicated.

2.03.2 Products shall be as manufactured by Phillips Manufacturing Co. Products as manufactured by others will be considered acceptable subject to full compliance with the products specified.

2.03.3 Materials:

Corner Bead:	Everlast
Casing Bead:	U-200
Control Joint:	093

2.04 FASTENERS

2.04.1 All fasteners for gypsum board shall be screws. Screws shall conform to Gypsum Association GA-216, Type W Bugle Head screws, and shall be of length as recommended by the gypsum board manufacturer for the thickness of the material, and for the fire ratings as noted.

2.04.2 Adhesives shall be of the type recommended by the gypsum board manufacturer for the installation indicated.

3.0 EXECUTION

3.01 INSTALLATION OF GYPSUM CEILING PANELS

3.01.1 Apply gypsum board panels of maximum practical length with long dimensions at right angles to supports. Center end joints over supports and stagger them from those of adjacent panel rows. Fit joints neatly and accurately. Secure panels to supports with screws spaced at 12" on center at edge of panels and in panel field.

3.02 INSTALLATION OF GYPSUM WALL PANELS

3.02.1 Apply gypsum board panels to sidewalls after gypsum board ceilings are erected. Apply panels of maximum practical length with long dimension parallel to supports. Center end joints over supports and stagger them from those of adjacent panel rows. End joints on opposite sides of a partition shall occur on different studs. Bring boards into contact with each other but do not force into place. Secure panels to supports with screws spaced at 16" on center at edge of panels and in panel field.

3.02.2 Openings. End joints shall occur at least 8 inches on either side of openings in walls. No joint shall align with edges of openings, and joints above openings shall be centered over openings.

3.02.3 Hold panels in firm contact with the supporting members while the fasteners are being driven. Fasteners shall proceed from central portion of board towards ends and edges. Drive fasteners home with the heads slightly below the surface of the board in a dimple formed by the driving tool. Take care to avoid breaking the paper face. Remove improperly driven fasteners. Secure panels to supports with screws.

3.02.4 After installation, pound on walls and ceilings to detect loose screws, and push on board adjacent to fasteners to see if there is movement. If loose fasteners are detected, drive them tight. Whenever fasteners have punctured paper, hold board tight against framing and install another fastener properly, approximately 1-1/2 inches from that which punctured paper and remove the faulty fastener. When attaching wallboard to second side of a partition, check opposite side for fasteners loosened by pounding and drive them tight again.

3.03 FIRE RATED WALLS AND CEILINGS

3.03.1 Install gypsum board at fire rated walls and ceilings in strict accordance with the U.S. Gypsum Manual for rated walls and ceilings, including spacing of fasteners, fire taping and other requirements.

3.04 INSTALLATION OF ACCESSORIES

3.04.1 Apply corner beads at all outside corners with screws at 9 inch centers maximum on each flange of the bead, with screws aligned.

3.04.2 Apply casing beads to all exposed edges and ends of gypsum wallboard, where indicated on the drawings with screws at 9 inch centers.

3.04.3 Install control joints where indicated on the drawings. Control joints located in fire rated wall or ceilings shall be set in continuous bead of fire rated caulking, to form a continuous seal behind the joint material.

3.04.4 Control joints at soffits shall be continuous from wall horizontally through bottom surface of the soffit, and vertically to ceiling surface. Where gypsum board soffits intersect suspended acoustical tile ceilings, control joints shall continue to above the line of the ceiling.

3.05 JOINT AND CORNER TREATMENT

3.05.1 Taping. Apply a uniformly thin layer of joint compound over the joint approximately 4 inches wide. Center tape over the joint and embed into the compound, leaving sufficient joint compound under tape to provide proper bond. Reinforce wall angles and inside corner angles with tape folded to conform to the angle and embedded into the compound.

3.05.2 Finishing Joints. After compound is thoroughly dry, cover the tape with a coat of joint compound or topping compound spread over the tape approximately 3 inches on each side of the tape and feathered out at the edge. After thoroughly dry, apply another coat of joint compound or topping compound with a slight, uniform crown over the joint. This coat shall be smooth and the edges feathered approximately 3 inches beyond the preceding coat.

3.05.3 Finishing Corners. Coat inside corners with at least one coat of joint compound or topping compound with the edges feathered out. Conceal flanges of wallboard corner bead by at least two coats of compound or topping compound feathered out approximately 9 inches on both sides of the exposed metal nose.

3.05.4 Finishing heads and dimples. Apply three coats of joint compound or topping compound. Allow 24 hours drying time between coats.

3.05.5 Drying and Sanding. Allow each application of compound to joints and nail heads to dry, then sand if necessary. Caution shall be used to avoid roughing of wallboard paper.

3.06 FINISH OF GYPSUM DRYWALL

3.06.1 Gypsum drywall finish shall be in accordance with the following schedule:

- .1 At all exposed walls, soffits and ceilings, gypsum board shall be smooth finish, painted.

3.07 INSTALLATION OF ACCESSORIES

3.07.1 Apply corner beads at all outside corners with screws at 9 inch centers maximum on each flange of the bead, with screws aligned.

3.07.2 Apply casing beads to all exposed edges and ends of gypsum wallboard, where indicated on the drawings with screws at 9 inch centers.

3.07.3 Install control joints where indicated on the drawings. Control joints located in fire rated wall or ceilings shall be set in continuous bead of fire rated caulking, to form a continuous seal behind the joint material.

3.07.4 Control joints at soffits shall be continuous from wall horizontally through bottom surface of the soffit, and vertically to ceiling surface. Where gypsum board soffits intersect suspended acoustical tile ceilings, control joints shall continue to above the line of the ceiling.

SECTION 9651

VINYL BASE

1.0 GENERAL

1.01 DELIVERY, STORAGE AND HANDLING

1.01.1 Delivery and Storage. Material shall be delivered in unbroken, sealed packages, with the manufacturer's name and brand stamped thereon. Material shall not be stored in newly plastered or drywalled rooms or rooms otherwise exposed to dampness.

1.02 JOB CONDITIONS

1.02.1 Temperature. Materials shall be maintained at a temperature of 70 degrees Fahrenheit for 48 hours or more before they are installed. A temperature of 70 degrees Fahrenheit or more shall be maintained in areas receiving composition flooring, for a period beginning 48 hours before installation is begun and ending 48 hours after installation is complete.

1.02.2 Sequencing. Work shall not begin until after painting is completed.

1.03 SHOP DRAWINGS

1.03.1 Submit shop drawings to the Architect in accordance with the General Conditions for approval before installation. Shop drawings shall include actual samples of each color of material to be used.

2.0 PRODUCTS

2.01 MATERIALS

2.01.1 Vinyl base shall be 4 inch high coved base, as manufactured by the Johnson Rubber Company, Burke or Armstrong Company. Vinyl base shall be continuous roll, and shall be installed as scheduled on the drawings.

2.01.5 At locations scheduled to receive sheet vinyl base, sheet vinyl base shall be flash coving, integral coved sheet vinyl, an extension of the sheet vinyl floor material turned up the wall to 4 inch height. Provide wood or plastic cove strip continuous between the wall and sheet vinyl cove at floor line. Cap coved sheet vinyl base with continuous metal cap strip. Provide metal trim for all inside and outside corners, installed integrally with sheet vinyl to achieve a watertight joint.

3.0 EXECUTION

3.02 PREPARATION

3.02.1 Surfaces shall be clean and free of grease, oil, paint, and foreign matter. Remove dust by vacuum cleaning after a light sanding with a power disk floor machine with a coarse emery pad. Fill holes, cracks, and other irregularities with nonshrink fillers.

3.03 INSTALLATION

3.03.2 Flash Cove. Install wood or plastic cove strip continuous between the wall and sheet vinyl cove at floor line. Install continuous metal cap strip at 4 inches above floor line, secure to wall in strict accordance with manufacturer's recommendations for a continuous tight fit. Provide metal corner trim for all inside and outside corners, installed integrally with sheet vinyl to achieve a watertight joint. After completion of installation, caulk along top of cap strip, between wall and cap strip for a watertight joint.

3.03.3 Vinyl Base. Install vinyl base on finished walls after painting and installation of floor covering is complete. Vinyl base shall be set in continuous layer of adhesive.

3.04 ADJUSTING AND CLEANING.

3.04.1 Cleaning and waxing of resilient flooring shall be done by the Owner. Contractor shall be responsible for final construction cleaning of resilient flooring, which shall consist of removal of all dust by damp mopping only.

SECTION 9800

PAINTING

1.0 GENERAL

1.01 DESCRIPTION

1.01.1 This specification covers preparation of surfaces, performance and completion of painting of all interior and exterior building surfaces scheduled to receive paint.

1.02 SUBMITTALS

1.02.1 Submit shop drawings to the Architect with the following information:

- .1 Samples of each type of finish and color. Paint samples shall be submitted on 8 1/2 inch x 11 inch Mead Mark I cover paper, coated on one side, with paint sprayed or applied with a foam rubber roller. Samples shall be submitted within 60 days after the contract date. The back of paint samples shall show the paint manufacturer and trade name of the proposed paint.

1.03 DELIVERY

1.03.1 Delivery of all materials to the job site shall be in original sealed containers, bearing labels of the paint manufacturer.

1.04 JOB CONDITIONS

1.04.1 Temperature of surfaces and surrounding air shall be between 50 and 90 degrees F. during painting and drying. Surfaces to be painted shall not be wet or damp. Do not apply exterior paint in rain, fog, or mist, or when the relative humidity exceeds 85 percent. Protect adjacent work by drop cloths, masking tape, or other suitable means.

1.05 WORK NOT TO BE PAINTED

1.05.1 Do not paint the following:

- .1 Nonferrous metals such as aluminum, stainless steel, nickel, chromium plate, copper or bronze, unless noted otherwise, except that all mechanical hoods, roof caps, furnace flues and vents, pipes, and all other items which are exposed to view shall be painted.
- .2 Concealed surfaces.
- .3 Labels and plates, such as factory and Underwriter Laboratories labels, and equipment identification plates.

2.0 PRODUCTS

2.01 PAINT

2.01.1 Paint shall be furnished by Sherwin-Williams Paint Co, Pittsburg Paint, or Diamond Vogel, Thinners shall be as approved by the paint manufacturer.

3.0 EXECUTION

3.01 INSPECTION

3.01.1 Condition of Surfaces. The Contractor shall examine surfaces which are scheduled to receive paint, stain, varnish or other coatings and report to the Architect any surfaces which cannot be put into proper condition for finishing by customary cleaning, sanding, puttying, or other similar preparation operations. Application of the first coat shall constitute acceptance of the surfaces to receive finish.

3.02 SURFACE PREPARATION

3.02.1 Remove hardware, machined surfaces, plates, lighting fixtures, and similar items which are not to be painted or apply protective coverings before commencing surface preparation. Reinstall these items after painting is complete and dry.

3.02.2 Clean surfaces free of dirt, rust, scale, grease, and moisture.

3.02.3 Cementitious materials. Remove efflorescence, chalk, dust, dirt, grease, and oils and roughen as required to remove glaze. Correct alkalinity if this condition will cause blistering and burning of finish paint. Do not paint surfaces where moisture content exceeds eight percent unless otherwise permitted in the manufacturer's printed directions.

3.02.4 Ferrous metals. Wash non-primed metal surfaces with mineral spirits to remove dirt and grease and remove rust or scale by wire brushing or by sand papering clean. Omit prime coat on metal surfaces which have been shop primed unless touch-up of damaged prime coats is required. Wire brush damaged shop-applied prime coats and touch-up with the same primer as shop coat. Apply barrier coat or remove primer and re-prime surfaces which are shop primed with primers that are incompatible with finish coats.

3.02.5 Galvanized metal. Clean and treat chemically with a compound designed for this purpose, such as "Lithoform", "Stibley", or "Solfo Metallic Coat", in strict accordance with the manufacturer's instructions.

3.02.6 Previously painted surfaces. Sand hard glossy finishes to insure adhesion. Spot prime with primer specified for new surfaces where existing paint or primer has been partially removed by blistering, peeling, rupture, or cracking. Completely remove existing finish if 25 percent or more of the existing finish has failed or can be easily scraped off the surface.

3.02.7 All wood surfaces shall be cleaned from dirt, oil, and other foreign substances, and shall be sanded smooth. Knots shall be sealed with knot sealer, and knot holes shall be puttied flush with the surface. Wood shall not be painted while it is damp.

3.02.8 Gypsum board shall be free of dust and dirt, and shall be thoroughly dry.

3.03 MIXING

3.03.1 Mix and prepare paint in accord with the manufacturer's recommendations. Tint undercoats to match finish coats.

3.04 APPLICATION

3.04.1 Apply materials under adequate illumination with brush, roller, or spray, in accord with the manufacturer's recommendations and as approved by the Architect. Spread evenly and flow on smoothly without runs, sags, or other surface imperfections.

3.04.2 Apply subsequent coat only after previous coat is thoroughly dry. Sand between enamel and varnish coats applied to wood or metal with fine sandpaper.

3.04.3 Apply subsequent coats when stains, undercoats, or other conditions show through final coat of paint, until the paint film is of uniform finish, color, and appearance.

3.04.4 Spray application of paints on new gypsum board walls and ceilings will be permitted, provided the application is by airless-type spray equipment, and provided the application by spray is followed by a roller on all surfaces. Roller shall thoroughly work the paint into the pores and onto the surface for complete surface coverage. Conventional paint spray equipment will be permitted on metal door frames, metal doors, and metal fabrications. Sprayed surfaces shall be smooth, free of imperfections and paint runs, and shall be completely covered by each coat. Do not double back to build up film thickness of two coats in one pass.

3.05 ADJUSTING AND CLEANING

3.05.1 Clean adjacent and other surfaces which are smeared or splattered as a result of the painting operation.

3.06 PAINT SCHEDULE

3.06.1 Paint schedule shall be as indicated below. Colors shall be as selected by the Owner. Prime coats shall be tinted to the approximate color of finish coats. Materials shall be painted according to the following schedule, which is based on products as manufactured by Sherwin-Williams Paint Co.

INTERIOR WORK

1. **FERROUS METAL**

Alkyd Systems (Water based):
Semi-Gloss Finish

1st Coat: S-W Pro Industrial Pro-Cryl Universal Primer, B66-1310 Series
(5.0 mils wet, 2.0 mils dry).

2nd Coat: S-W ProMar 200 Waterbased Acrylic-Alkyd Semi-Gloss, B34-8200 Series.

3rd Coat: S-W ProMar 200 Waterbased Acrylic-Alkyd Semi-Gloss, B34-8200 Series
(4.0 mils wet, 1.7 mils dry per coat).

2. **ALUMINUM, GALVANIZED**

Latex Systems:

Egg-Shell / Satin Finish:

1st Coat: S-W Pro Industrial Pro-Cryl Universal Primer, B66-1310 Series (5.0 mils wet,
2.0 mils dry).

2nd Coat: S-W ProMar 200 Zero VOC Latex Eg-Shel, B20-2600 Series.

3rd Coat: S-W ProMar 200 Zero VOC Latex Eg-Shel, B20-2600 Series
(4 mils wet, 1.7 mils dry per coat).

3. **WOOD TRIM**

Alkyd Systems (Water based):

Semi-Gloss Finish:

1st Coat: S-W Premium Wood & Wall Primer, B28W8111 (4 mils wet, 1.8 mils dry).

2nd Coat: S-W Industrial Water Based Alkyd Urethane Enamel Semi-Gloss,
B53-1150 Series.

3rd Coat: S-W Industrial Water Based Alkyd Urethane Enamel Semi-Gloss,
B53-1150 Series ((4.0-5.0 mils wet, 1.4 - 1.7 mils dry per coat).

4. **DRYWALL**

Latex Systems:

Egg-Shell / Satin Finish:

1st Coat: S-W Premium Wall & Wood Interior Latex Primer, B28W08111
(4 mils wet, 1.8 mils dry).

2nd Coat: S-W Emerald Interior Latex Satin, K37 Series.
(4 mils wet, 1.7 mils dry per coat)

3rd Coat: S-W Emerald Interior Latex Satin, K37 Series
(4 mils wet, 1.7 mils dry per coat).

- .5 **Epoxy Systems**
(Water Based):
Egg-Shell/Low Luster Finish:
1st Coat: S-W ProMar 200 Zero VOC Interior Latex Primer, B28W2600
(4 mils wet, 1.5 mils dry).
2nd Coat: S-W Pro Industrial Pre-Catalyzed Waterbased Epoxy, K45- Series.
3rd Coat: S-W Pro Industrial Pre-Catalyzed Waterbased Epoxy, K45- Series
(4 mils wet, 1.5 mils dry per coat).

6. **STAIN AND VARNISH:**
Satin Finish:
1st Coat: S-W WoodClassics 250 Stains. See room finish schedule for color
2nd Coat: S-W WoodClassics Waterborne Polyurethane Varnish, A68 Series.
3rd Coat: S-W WoodClassics Waterborne Polyurethane Varnish, A68 Series
(4 mils wet, 1.0 mil dry per coat).

Ensure stain color matches Old Masters Rich Mahogany. Use Old Masters Rich Mahogany if equivalent Sherwin Williams stain does not match. Provide sample for approval.

EXTERIOR WORK

1. **FERROUS METALS**
Latex Systems:
Gloss Finish:
1st Coat: S-W Pro Industrial Pro-Cryl Universal Primer, B66-1310 Series
(5.0-10.0 mils wet, 1.8-3.6 mils dry).
2nd Coat: S-W A-100 Exterior Latex Gloss, A8 Series
(4.0 mils wet, 1.3 mils dry per coat).
3rd Coat: S-W A-100 Exterior Latex Gloss, A8 Series
(4.0 mils wet, 1.3 mils dry per coat).
2. **ALUMINUM, GALVANIZED**
Latex Systems:
Satin Finish:
1st Coat: S-W A-100 Exterior Latex Satin, A82 Series.
(4.0 mils wet, 1.5 mils dry per coat)
2nd Coat: S-W A-100 Exterior Latex Satin, A82 Series
(4.0 mils wet, 1.5 mils dry per coat).

SECTION 9975

FIBERGLASS WALL PANELS

1.0 GENERAL

1.01 RELATED WORK SPECIFIED ELSEWHERE

Gypsum Drywall	Section 9250
Sealants	Section 7900

1.02 SUBMITTALS

1.02.1 Submit shop drawings to the Architect in accordance with the General Conditions and General Requirements.

2.0 PRODUCTS

2.01 FIBERGLASS WALL PANELS

2.01.1 Fiberglass wall panels shall be Fire-X Glasbord FRP panels as manufactured by Kemlite Company. Panel thickness shall be 0.09 inches, and shall be 4 ft. x 8 ft., in color of white. Panels shall have normal water absorption property of 0.08%, and a normal coefficient of linear expansion of .00017 inches per inch per degree F. Panels shall meet flame spread and smoke development ratings specified for Class A interior finish materials, as per NFPA 101. Products as manufactured by the following are also acceptable, subject to compliance with these specifications:

Nudo Products, Inc.
Filon Products
Sequentia, Inc.

2.01.2 Provide all accessories including PVC moldings for inside corner, outside corner, divider and end caps. Color of accessories shall match the color of panels.

3.0 EXECUTION

3.01 SURFACE PREPARATION

3.01.1 Walls must be flat, clean, dry and free of all dirt, dust or grease.

3.02 INSTALLATION

3.02.1 Install wall panels by mastic application, setting in a complete bed of mastic of the type recommended by the manufacturer of the wall panels. Spread mastic with a notched trowel evenly over the entire surface, such that full contact bonding will occur between the wall panel and the substrate.

3.02.2 Bottom of panels shall be installed 4 inches above finish floor, such that bottom of fiberglass wall panels corresponds to the top of base.

3.02.3 Leave not less than 1/4 inch gap at ceiling, and 1/8 inch between wall panels for normal expansion and contraction. Allow not less than 1/8" gap around pipes, conduits, fittings and other projections. Fill gaps with silicone caulk to complete moisture seal.

3.01.4 Provide PVC moldings for inside corner, outside corner, divider and end caps. Seal all edges where panels are in contact with moldings to insure a complete moisture seal.

SECTION 10155

PLASTIC TOILET COMPARTMENTS

1.0 GENERAL

1.01 SUBMITTALS

1.01.1 General: Submit the following in accordance with Conditions of Contract and Division 1 Specification Sections.

1.01.2 Product data for materials, fabrication, and installation including catalog cuts of anchors, hardware, fastenings, and accessories.

1.01.3 Shop drawings for fabrication and erection of toilet compartments assemblies not fully described by product drawings, templates, and instructions for installation of anchorage devices built into other work.

1.01.4 Samples of full range of colors for each type of unit required. Submit 6-inch-square samples of each color and finish to be used in work, for color verification after selections have been made.

1.02 PRODUCT DELIVERY, STORAGE AND HANDLING

1.02.1 Materials shall be stored in their original containers until ready for installation to prevent damage to the units and finish.

1.03 QUALITY ASSURANCE

1.03.1 Field Measurements: Take field measurements prior to presentation of shop drawings and fabrication, where possible, to ensure proper fitting of work. However, allow for adjustments where taking of field measurements before fabrication might delay work.

2.0 PRODUCTS

2.01 MANUFACTURERS

2.01.1 Toilet partitions shall be as manufactured by Scranton Products.. Products as manufactured by other manufacturers shall be considered subject to compliance with these specifications:

2.02 MATERIALS

2.02.1 General. Provide materials, which have been selected, for surface flatness and smoothness. Exposed surfaces, which exhibit pitting, stains, discoloration, or other imperfections on finished units are not acceptable.

2.02.2 Solid Plastic: High density, solid polymer resin with homogenous color throughout. Provide material not less than 1 inch thick with seamless construction with edges eased.

2.02.3 Pilaster Shoes and Caps: ASTM A-167, Type 302/304 stainless steel, not less than 3 inches high, 0.0396 inch thick (20 gage), finished to match hardware.

2.02.4 Brackets: Anodized aluminum continuous wall bracket with minimum 8 fasteners to wall or pilaster and 4 fasteners to panel; for attaching panels to walls and pilasters.

2.02.5 Hardware and Accessories: Manufacturer's heavy duty operating hardware and accessories of stainless steel or aluminum.

2.02.6 Overhead Bracing: Continuous extruded aluminum, antigrip profile, with clear anodized finish.

2.02.7 Anchorages and Fasteners: Manufacturer's standard exposed fasteners of stainless steel, with theft-resistant-type heads and nuts. For concealed anchors, use hot-dip galvanized, cadmium-plated, or other rust-resistant protective-coated steel.

2.03 FABRICATION

2.03.1 General: Furnish standard doors, panels, screens, and pilasters fabricated for compartment system. Furnish units with cutouts, drilled, holes, and internal reinforcement to receive partition-mounted hardware, accessories, and grab bars, as indicated.

2.032 Door Dimensions: Unless otherwise indicated, furnish 24" wide door for standard stalls and 34-inch-wide for stalls equipped for use by handicapped.

2.033 Overhead-Braced Compartments and Screens: Furnish galvanized steel supports and leveling bolts at pilasters as recommended by manufacturer to suit floor conditions. Make provisions for setting and securing continuous, extruded, aluminum, antigrip, overhead bracing at top of each pilaster. Provide shoe at each pilaster to conceal supports and leveling mechanism.

2.034 Hardware: Furnish hardware for each compartment to comply with ANSI A117.1 for handicapped accessibility and as follows:

- .1 Hinges: Cutout inset type, adjustable to hold door open at any angle up to 90 degrees. Provide gravity type, spring-action cam type, or concealed torsion rod type to suit manufacturer's standards.
- .2 Latch and Keeper: Door strike, keeper, and latch housing shall be fabricated from heavy aluminum extrusion with clear anodized finish, surface mounted and through-bolted with one-way sex bolts.
- .3 Slide bolt and button shall be heavy aluminum with "Tough-Coat Black" finish.
- .4 Door Pull: Manufacturer's standard unit for handicapped accessible compartment doors.
- .5 Panel Protector: Aluminum protector on bottom edge of all stall dividers.

3.0 EXECUTION

3.01 INSTALLATION

3.01.1 General: Comply with manufacturer's recommended procedures and installation sequence. Install compartment units rigid, straight, plumb, and level. Provide clearances of not more than ½ inch between pilasters and panels, and not more than 1 inch between panels and walls.

3.01.2 Overhead-Braced Compartments and Screens: Secure pilasters to floor and level, plumb, and tighten installation with devices furnished. Secure overhead brace to each pilaster with not less than two fasteners. Hang doors and adjust so that tops of doors are parallel with overhead brace when doors are in closed position.

3.02 ADJUST AND CLEAN

3.02.1 Hardware Adjustment: Adjust and lubricate hardware for proper operation. Set hinges on in-swinging doors to hold open approximately 30 degrees from closed position when unlatched. Set hinges on out-swinging doors to return to fully closed position.

3.02.2 Clean exposed surfaces of partition systems using materials and methods recommended by manufacturer, and provide protection as necessary to prevent damage during remainder of construction period.

SECTION 10400

IDENTIFYING DEVICES

1.0 GENERAL

1.01 SHOP DRAWINGS

1.01.1 Submit shop drawings in accordance with the General Conditions and General Requirements. Shop drawings shall include an actual sample of the products, indicating color.

1.02 DELIVERY, STORAGE AND HANDLING

1.02.1 Deliver materials and store in such a manner as to prevent damage to identifying devices.

2.0 PRODUCTS

2.01 IDENTIFYING DEVICES

2.01.1 Identifying devices shall be colored plastic signs, approximately 2 1/2 inches high and of the length required for the engraved image, x 1/8 inch thick, with a one inch high by 1/32 inch raised white lettering image, embossed onto the face layer of material. Provide with raised braille markings corresponding to room names located below engraving. Signs shall be designed to meet the requirements of A.D.A. Materials shall be as manufactured by American Sign Company, ASI Modulex, or Best Sign Systems.

2.01.2 Signs shall be provided for rooms as indicated in the following schedule for rooms shown on the plans.

.1 Provide signs for individual rooms as follows:

MEN (international handicapped/gender symbol)
WOMEN (international handicapped/gender symbol)
MECHANICAL
HOME LOCKER ROOM (To be mounted on exterior of building)
GUEST LOCKER ROOM (To be mounted on exterior of building)
ELECTRICAL (To be mounted on exterior of building)

3.0 EXECUTION

3.01 INSTALLATION

3.01.1 Install signs for individual rooms as indicated above on the wall adjacent to the room door to each room respectively, at 60" above finish floor. For locations where mounting to the wall is impractical, mount signs directly on the door to the room. Obtain approval of Architect regarding which shall be door mounted signs. Signs shall be attached to wall or door with factory applied self adhesive tape supplied by the sign manufacturer.

SECTION 10520

FIRE EXTINGUISHERS AND CABINETS

1.0 GENERAL

1.01 SUBMITTALS

1.01.1 Submit shop drawings to the Architect in accordance with the General Conditions and General Requirements.

1.02 DELIVERY, STORAGE AND HANDLING

1.02.1 Fire extinguishers and cabinets shall be delivered and stored in a manner to prevent damage to the units, and subsequent loss of charge.

1.03 EXISTING FIRE EXTINGUISHERS AND CABINETS

1.03.1 Existing fire extinguishers and cabinets shall remain as indicated on the drawings. Contractor shall verify that existing fire extinguishers are fully charged, and charge those that are less than fully charged.

1.03.2 Selected existing fire extinguisher cabinets and fire extinguishers are schedule to be removed. See drawings for specific locations.

2.0 PRODUCTS

2.01 FIRE EXTINGUISHERS

2.01.1 Fire extinguishers shall be Type ABC, multi-purpose dry chemical type, having a nominal capacity of 5 pounds. Products as manufactured by Larsen's, J.L. Industries, or Muckle Manufacturing shall be acceptable.

2.02 FIRE EXTINGUISHER CABINETS

2.02.1 Fire extinguisher cabinets shall be semi-recessed, with a white baked enamel finish, and a full lite door with a break-away acrylic panel, model no. 2409-R3 as manufactured by Larsen's Manufacturing Company. Glass panel units will not be allowed. Products as manufactured by J.L. Industries or Muckle Manufacturing shall also be acceptable, subject to compliance with this specification.

3.0 EXECUTION

3.01 INSTALLATION

3.01.1 Install fire extinguisher cabinets in locations as indicated on the drawings, which are marked "FEC". Furnish one fire extinguisher per each cabinet.

SECTION 10800

TOILET ACCESSORIES

1.0 GENERAL

1.01 SUBMITTALS

1.01.1 Submit shop drawings in accordance with the General Conditions and General Requirements.

1.02 PRODUCT DELIVERY, STORAGE, AND HANDLING

1.02.1 Toilet accessories shall be stored in their original cartons until ready for installation.

2.0 PRODUCTS

2.01 TOILET ACCESSORIES

2.01.1 Toilet accessories shall be as manufactured by Bobrick, unless noted otherwise, and model numbers specified are of same. Products as manufactured by McKinney/Parker, American Specialties Company, or Basco are also acceptable, subject to compliance with this specification.

2.01. Provide toilet accessories as scheduled on the drawings.

3.0 EXECUTION

3.01 PREPARATION

3.01.1 Provide solid wood blocking in walls at locations where accessories are to be mounted in frame walls.

3.02 MOUNTING

3.02.1 Mount accessories at the heights above finish floor line as indicated on the drawings.

3.01.2 Accessories shall be mounted with wood screws into wood blocking.

SECTION 12300

CABINETS AND COUNTERTOPS

1.0 GENERAL

1.01 RELATED WORK SPECIFIED ELSEWHERE

Solid Polymer Fabrications

Section 6650

1.02 SUBMITTALS

1.01.1 Submit shop drawings in accordance with the General Conditions and General Requirements. Shop drawings shall show materials, dimensions, cabinet cut details, and sink locations.

1.01.2 Submit samples of actual cabinet box, showing all features of each type of cabinet including doors, drawers and drawer guides, finish and hardware.

1.03 DELIVERY, STORAGE AND HANDLING

1.03.1 Deliver each unit in its own individual carton with markings showing the location of installation. Provide corner pads and posts to protect finished parts from dust, scratches or other damage.

1.04 JOB CONDITIONS

1.04.1 Verify dimensions by field measurement prior to fabrication. Fabricate countertops for scribe fit.

2.0 PRODUCTS

2.01 INSTITUTIONAL CASEWORK

2.01.2 Cabinets shall be plastic laminate covered particle board, Series L44, Full Overlay Door with 3mm PVC edge, as manufactured by LSI Corporation of America, and shall be of the sizes and configurations as indicated on the drawings. Provide blind corner cabinets as required.

2.01.3 Cabinets shall be built of high density particle board cores, and high pressure plastic laminate for all exterior faces. Provide cabinet liner for all exposed inside faces of casework. Edging for doors, drawers, cabinet vertical end panel edges shall be 3mm thick PVC solid high impact material, applied by edging machine, trimmed, buffed and corner radiused for consistent design.

2.01.9 All other features of cabinet specifications shall be as manufacturer's standard for line specified.

2.02 OTHER ACCEPTABLE MANUFACTURERS

2.02.1 Cabinets as manufactured by "Tru-Built or T M I are also acceptable subject to compliance with these specifications.

2.02.2 Cabinets as manufactured by independent cabinet shops will be acceptable, subject to full compliance with these specifications.

2.03 VANITY PIPE COVER

2.03.1 Vanities at toilets shall be solid surfacing as specified in Section 6650. Vanity pipe covers at front edge of vanity shall be plastic laminated covered particle board as indicated. Provide units of the dimensions and profiles as indicated on the drawings. Color shall be as selected by the Owner.

2.04 COUNTERTOPS

2.04.1 Countertops shall be fabricated of high density particle board cores, covered with high pressure plastic laminate. Front edge shall be postformed "waterfall" type (no substitution) at all locations, unless otherwise indicated on drawings.

3.0 EXECUTION

3.01 INSTALLATION

3.01.1 Provide solid wood blocking in all framed walls behind base and wall cabinets, and behind shelving units. Provide expansion anchorage devices where cabinets are to be installed in masonry walls.

3.01.2 Fit, scribe and install cabinets and countertops where indicated on the drawings in strict accordance with manufacturer's installation instructions, with trimming and scribing neatly and accurately done. Secure to walls with screws anchored into solid wood blocking in walls. Provide filler strips where required to insure full operation of all cabinet door swings and drawer travel, to eliminate interference of installed casework with other items of construction such as light switches, other doors, hardware and other casework.

3.01.3 After installation, verify that all cabinets and countertops are installed securely and accurately, and that all trim is in place. All hardware shall be properly adjusted for smooth operation. Touch up all surfaces damaged during construction to the satisfaction of the Architect, and in accordance with the manufacturer's recommendations. Cabinets with surfaces damaged beyond reasonable repair, as determined by the Architect, shall be removed and replaced at no additional cost to the Owner. Remove all packing materials from cabinets and dispose of properly.

3.01.4 Caulk between countertop and wall, between soffit and wall cabinets, and between cabinet body and wall, using caulk of the color compatible with the color of the countertops and cabinets.



NASA and NASB 2022 Labor Relations

October 5-6, 2022
Cornhusker Marriott - Lincoln

Wednesday, October 5

Preconference Workshop: The ABCs of Negotiations *with Perry Law Firm*

The single biggest part of a school district's budget is personnel costs. Salaries and benefits alone usually represent around 90% of a district's total expenses. Therefore, it is absolutely essential that a district understand the negotiation process and legal requirements in order to ensure that these expenses are a reasonable and good use of taxpayer dollars. In this session, we will walk through the negotiation process and offer practical suggestions, including specific items to consider heading into the 2023-2024 negotiations timeline.

Memorial Stadium and More Tour

After the Preconference, learn more about your beloved Huskers with a facilities tour. Osborne Athletic Complex (North Stadium) was built in 2006 and includes a beautiful 40' waterfall, Sullivan art mural, video kiosk, Husker Nation Championship Drive donor display, a peek at the Suh Strength Complex, National Championship and Bowl Trophy displays, and the Nebraska Heisman Room. You will also see the major award winner hallway, Hawks indoor practice facility, and tunnel walk onto the field.



Keynote: Thursday, October 6 **Moving From Ordinary to Extraordinary:** **Why Some Schools and Boards Thrive**

with Andrew McCrea

Andrew McCrea helps tell the stories of extraordinary communities an schools all across the nation. He served three terms on his local school board and has done countless interviews with teachers, administrators, and community leaders who are helping their school districts and towns thrive. What sets the extraordinary apart from the ordinary? Andrew will share practical steps we can take to help our schools, students and communities.

Concurrent Session Topics Include:

- Wage Deductions and Payroll Issues
- Employee Contracts and Mistakes to Avoid
- Terminating Employment for Classified Employees
- Workers' Compensation Issues
- EHA Health Care Member Support
- Building the Capacity for Change
- Reductions in Force
- FLSA/FMLA Revisited
- Unique Contracting Issues in 2022
- Use of School Resources, Accountability and Disclosure, and Free Speech
- Summer Activities, Clubs, Booster and Foundation Events, and The Law
- And More!

For more information and to register online visit: www.ncsa.org

Conference At-A-Glance

Wednesday, October 5

- 12:30 p.m. Registration Open
1:00 p.m. **The ABCs of Negotiations** with *The Perry Law Firm*
5:00 p.m. Memorial Stadium and More Tour

Thursday, October 6

- 7:30 a.m. Registration and Continental Breakfast
Exhibits Open
8:15 a.m. Welcome and Opening Keynote
Moving From Ordinary to Extraordinary:
Why Some Schools and Boards Thrive with *Andrew McCrea*
9:30 a.m. Exhibit Break
9:45 a.m. Concurrent Session I
10:45 a.m. Exhibit Break
11:00 a.m. Concurrent Session II
12:00 p.m. Lunch
1:00 p.m. Concurrent Session III
2:00 p.m. Exhibit Break
2:15 p.m. Concurrent Session IV
3:15 p.m. Adjourn

Lodging

Cornhusker Marriott - Lincoln

(866) 706-7706

\$109 + tax

Mention: NCSA/NASB Labor Relations

Book by September 13, 2022

Registration

Name: _____
School District/Agency: _____
Address: _____
City: _____ State: _____ Zip: _____
Phone: _____ Email: _____

Preconference Registration - October 5

**Please note, preconference is a separate fee*

Preconference _____ \$75

Yes, I will attend the tour _____

Limited to 40 attendees

Registration - October 6

NCSA/NASB Member _____ \$150

Non-Member _____ \$300

Total Registration \$ _____

Return forms to:

 NCSA
455 S 11th St., Ste A
Lincoln, NE 68508

 402-476-7740

All Cancellation requests must be received by Friday, September 30, 2022.

For more information and to register online visit: www.ncsa.org

2023 STATE EDUCATION CONFERENCE
NOVEMBER 15-17
CHI HEALTH CENTER - DOWNTOWN OMAHA

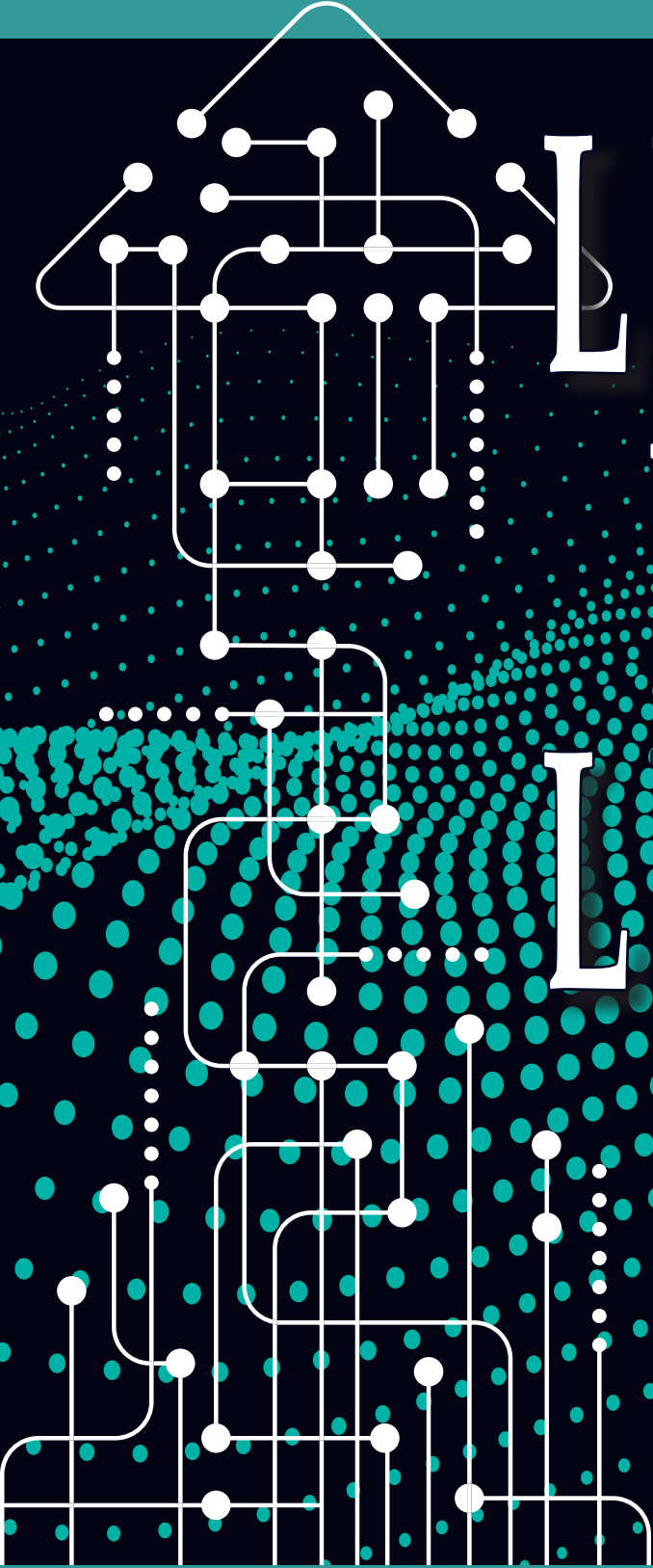

LEARNERS LEADING LEARNERS



Co-Sponsored by the Nebraska Association of School Boards
and the Nebraska Association of School Administrators



REGISTRATION & RESERVATIONS

REGISTRATION FOR THE 2023 STATE EDUCATION CONFERENCE WILL OPEN WEDNESDAY, SEPTEMBER 13, 2023

To register, go to www.NASBOnline.org

Log in using your email and password, and click the 'Events' tab to register.



Registration fees for the conference are as follows:

REGISTER SEPTEMBER 13 THROUGH NOVEMBER 3
PRE-CONFERENCE REGISTRATION
CANCELLATION FEE (PRIOR TO 11/4)

\$325 REGISTER NOVEMBER 4 THROUGH ON SITE **\$375**
\$100
\$150 (No refunds after the registration deadline)

HOTEL RESERVATIONS

TO RESERVE ACCOMMODATIONS AT THE CONFERENCE HOTELS YOU MUST FIRST REGISTER FOR THE CONFERENCE AS DESCRIBED ABOVE.

To qualify for a room, you must first register for the Conference.

Once your conference registration is complete, you will receive an email with your NASB Registration code and a Conference Hotel reservation link. The code will not be activated until 10:00 AM CT, Wednesday, September 27, 2023

SUBMIT YOUR CONFERENCE HOTEL ROOM REQUEST WEDNESDAY, SEPTEMBER 27, 2023.

THE OMAHA CONVENTION & VISITORS BUREAU WILL ACT AS THE HOUSING AGENT FOR ALL PROPERTIES.

Hilton Omaha - 1001 Cass Street
\$151 per night
ROOM REQUESTS WILL BE ACCEPTED UNTIL OCTOBER 15, OR UNTIL FULL

Omaha Marriott Downtown - 222 North 10th Street
\$169 per night
ROOM REQUESTS WILL BE ACCEPTED UNTIL OCTOBER 24, OR UNTIL FULL

A RESERVATION AT ONE OF THE ABOVE IS NOT REQUIRED TO ATTEND THE STATE EDUCATION CONFERENCE



ADA ACCESSIBLE/PARKING
 GENERAL PARKING
 HOTELS
 LOT ENTRANCES

SCHEDULE AT A GLANCE / PRE-CONFERENCE SESSIONS

WEDNESDAY, NOVEMBER 15

Pre-Conference Sessions
1:00 to 4:00 PM

Exhibitor Reception
4:00 to 5:30 PM

THURSDAY, NOVEMBER 16

Board Member/Mentor Collaboration
7:15 to 8:15 AM

Opening Keynote Speaker
8:15 to 9:30 AM

A - Breakout Sessions
9:45 to 10:45 AM

B - Breakout Sessions
11:15 AM to 12:15 PM

Thursday Luncheon Keynote Speaker
12:30 to 2:00 PM

C - Breakout Sessions
2:15 to 3:15 PM

D - Breakout Sessions
3:30 to 4:30 PM

FRIDAY, NOVEMBER 17

Classroom Showcase
8:00 to 11:30 AM

NASB Delegate Assembly
8:00 to 9:30 AM

NASA Membership Meeting
8:00 to 9:30 AM

E - Breakout Sessions
9:15 to 10:15 AM

F - Breakout Sessions
10:30 to 11:30 AM

Friday Luncheon Keynote Speaker
11:45 AM to 1:15 PM

PRE-CONFERENCE SESSIONS WEDNESDAY, NOVEMBER 15 - 1:00 TO 4:00 PM

SPEAK OUT, REACH OUT!

Boards are facing a sense of urgency due to the ever increasing need to engage parents and community. Boards provide a platform for parents and patrons to speak out through public comment but how does a board reach out through appropriate measures to ensure parents and patrons feel heard? Beyond the board meeting how do boards reach out and maintain a continuous dialogue with parents and community? Join us for a robust session that will include current challenges related to public comment policy and procedures, purposeful parent-community engagement, and mock scenarios to provide practical strategies.

**PRESENTERS: Marcia Herring, Caden Frank & Kari Stephens - NASB
Dana Wiseman & James Jones - Sutton Public Schools
Mike Hart & Brandon Desh - District OR1 Public Schools
Justin Knight - Perry Law Firm**

EDUCATOR WORKFORCE: STRATEGIES TO ATTRACT, DEVELOP, AND RETAIN A HIGH-QUALITY STAFF

National and state educator workforce data is important to solving issues that face Nebraska. You will hear Nebraska's story through data, be introduced to the national publication "5 Shifts to Address the National Educator Shortage", and share strategies that work to alleviate workforce challenges in our schools. Millard Public Schools representatives will share information about their homegrown programs that help them attract, develop, and retain teachers and administrators. A panel of administrators will share their journey toward implementing payment of student teachers including how they plan to fund the program in the future. Attendees will also learn about the NexGen Leadership Academy at UNK and how it provides a model for university and PK-12 school district partnerships to develop system-wide capacity and create a leadership and principal pipeline program.

**PRESENTERS: John Schwartz, Kevin Clark & Kim Saum-Mills - Millard Public Schools;
Dan Schnoes - ESU #3; Andy Rikli - Papillion LaVista Community Schools;
Jami Jo Thompson - Norfolk Public Schools; Jeff Rippe - Bellevue Public Schools;
Jason Brown - Bertrand Community School; Charles Wakefield - Omaha
Public Schools; Sara Skretta - UNL; Mike Teahon, Chelsea Feusner & Aprille
Phillips - UNK**

SUPERINTENDENT OF THE YEAR WILL BE RECOGNIZED AT THE THURSDAY LUNCHEON

NASB DELEGATE ASSEMBLY - FRIDAY, NOVEMBER 17 - 8:00 TO 9:30 AM

NASA MEMBERSHIP MEETING - FRIDAY, NOVEMBER 17 - 8:00 TO 9:30 AM

SCHOOL BOARD MEMBER OF THE YEAR WILL BE PRESENTED AT THE FRIDAY LUNCHEON

TO REGISTER FOR THE CONFERENCE VISIT WWW.NASBONLINE.ORG



BETTER TOGETHER PRINCESS SARAH

THURSDAY MORNING OPENING SPEAKER - 8:15 TO 9:30 AM

Princess Sarah has an extraordinary journey that has been featured on CNN, GMA, and BBC, among numerous other media outlets. She shares the story of reuniting with her birth father in "A Princess Found: An American Family, an African Chiefdom, and the Daughter Who Connected Them All". "A Princess Found" is now being adapted into a major motion picture for Disney Studios. Princess Sarah is a real-life Princess of Sierra Leone. In addition, she is a humanitarian, author, and speaker on building a culture of belonging. She uses her personal story of being adopted and growing up in a bi-racial family to illustrate understanding cultural differences.



THE MASTERPIECE IN YOU RICHARD HIGHT

THURSDAY LUNCHEON SPEAKER - 12:30 TO 2:00 PM

Internationally-known artist and keynote speaker Richard Hight hails from a military family with roots deep in the red dirt of Oklahoma. Overcoming challenges faced at a young age led to valuable lessons learned about focusing on strengths and recognizing possibilities, not limitations. His artistic gift allowed him to express his ideas, and his successes built his confidence. From this his mission emerged —Vision, Focus, Grit! Richard's impressionist approach to painting equips him to successfully communicate with his audience. When he performs for groups, he wants the audience to focus on the artistic process, not the finished canvas: he shows that trusting creative impulses can yield surprising and beautiful results. With his often humorous storytelling, he has entertained diverse audiences around the world. The vivid colors he selects, the broad flourishes that coalesce into a stunning image, and the passion Richard possesses: all of these harmonize into an imaginative encounter that inspires and compels those present. Richard is sure to ignite an artistic mindset in innovative leaders. Some events you attend - This one, you experience!



LEARNING FROM OUR NEW LEADERS GOVERNOR JIM PILLEN & COMMISSIONER BRIAN MAHER

FRIDAY LUNCHEON SPEAKER - 11:15 AM TO 1:15 PM

We are happy to welcome our new 2023 Nebraska leadership! Governor Jim Pillen will reflect on his first year along with vision and priorities for K-12 education moving forward. You will also have an opportunity to hear Brian Maher, Commissioner of Education, share his thoughts on education in our state and bring you up to speed on things at the Nebraska Department of Education.



BREAKOUT SESSIONS & TRACKS



BOARDSMANSHIP



CAREER & COLLEGE READINESS



COMMUNITY ENGAGEMENT



CURRICULUM



ESU



FACILITIES



LEGAL & POLICY



LEGISLATIVE & ADVOCACY



MANAGEMENT/ADMINISTRATION



NEW BOARD MEMBER



SAFETY



STUDENTS/EARLY CHILDHOOD



TECHNOLOGY



WELLNESS

A

A - BREAKOUT SESSIONS THURSDAY, NOVEMBER 16 - 9:45 TO 10:45 AM



A1 A SESSION LIKE NO OTHER

Despite an unprecedented filibuster resulting in the creation of large omnibus packages, the legislature passed several bills impacting K-12 education. From student discipline in the classroom to budget considerations in the board room, learn about all the bills districts will navigate. With an eye to 2024, Colby and Mike will breakdown the issues that will dominate the upcoming session.

PRESENTERS: Colby Coash - NASB; Mike Dulaney - NCSA



A2 ACCREDITATION 101: UNDERSTANDING THE MANDATORY REQUIREMENTS AND FLEXIBILITIES OF RULE 10

Whether you are a veteran administrator or new to the role, a Rule 10 review from the Office of Accountability, Accreditation and Program Approval can increase your confidence when building schedules, hiring teachers, and completing the annual Assurance Statement. This session will cover both the non-negotiables and built-in flexibilities of Nebraska's Rule 10: Regulations and Procedures for the Accreditation of Schools. NDE staff will also provide time for questions on current trends and challenges when reporting for compliance.

PRESENTER: Brad Dirksen - NDE



A3 IS MY DISTRICT DOING SOMETHING WRONG WITH SPECIAL EDUCATION?

It starts off with an angry phone call from a parent and now your Superintendent received notice that the Nebraska Department of Education has placed your district under corrective action in response to a special education complaint. Is your District alone? NDE investigated 35 cases during the 2022-2023 school year. In this session, attorneys from the Perry Law Firm will discuss the state complaint process for special education, the implications of corrective action, and how to avoid corrective action by implementing appropriate policies and procedures. This presentation will cover discipline for students with disabilities, accommodations, service logs, behavior intervention plans, and more!

PRESENTERS: Haleigh Carlson & Greg Perry - Perry Law Firm



TO REGISTER FOR THE CONFERENCE VISIT WWW.NASBONLINE.ORG

THURSDAY BREAKOUT SESSIONS



A4 AT THE BOARD TABLE – BEFORE, DURING, AND AFTER THE MEETING



Learn how the board can maximize time to ensure the regular board meeting agenda, utilization of best practice protocols and procedures, and how a collaborative culture between board members communicates a positive message to staff, parents, and patrons. The importance of integrating these components determines the board's effectiveness and the quality of education the district is providing. Join us to learn how to purposefully prepare for a board meeting that reflects cohesive board-superintendent leadership.



PRESENTERS: Marcia Herring & Stacie Higgins - NASB



A5 HOT TOPICS IN SCHOOL LAW

The (questionably) dynamic duo is back again this year to tell you all about recent updates in school law, including important court cases, new laws and legislation, and the legal issues boards and administrators should know about! Bring your questions, concerns, and lawyer jokes.

PRESENTERS: Steve Williams & Bobby Truhe - KSB School Law



A6 EDUCATOR SHORTAGE: IT'S TIME FOR ACTION!

The educator workforce shortage crisis is affecting schools and students across Nebraska. In this interactive session we will use the Nebraska Educator Shortage Summit Action Plan and AASPA's *"5 Shifts to Address the National Educator Shortage"* to discuss innovative ideas and recommendations for change at the local and state levels. You will also develop an action plan framework to address educator workforce challenges specific to your district. Join us as we exchange ideas, discuss strategies and implementation processes to continue the work of making sure all Nebraska districts have high quality educational leaders, teachers, and staff.

PRESENTER: Sara Skretta - UNL



A7 PUBLIC COMMENT: LEGAL CONSIDERATIONS UNDER THE OPEN MEETINGS ACT



In this session, we will walk through public comment as prescribed by the Open Meetings Act. Then, we will discuss real-world examples and how boards should handle both simple and complicated scenarios under the Open Meetings Act including complaints about staff members, discussions about student discipline matters, and threats of litigation.

PRESENTER: Justin Knight - Perry Law Firm



A8 DEVELOPING AND DEMONSTRATING LEARNING WITH TECHNOLOGY

The Westside Community Schools has a long history of using technology in instruction. This session will highlight examples of learning-focused iPad use with and by students in our current K-12 1:1 environment.

PRESENTERS: Paul Lindgren & Matthew Lee - Westside Community Schools



A9 BOARD AND COMMUNITY CULTURE IN CHALLENGING TIMES

In this session a panel of board members from across Nebraska will discuss the importance of a positive culture on school boards and in communities in these polarized times. The panel will share what has worked, what has caused challenges to success and strategies that have been implemented to improve the culture in their school and community.

PRESENTERS: Keith Rohwer & Cinde Wendell - NCSA



A10 MASTERING CHALLENGES TO IMPROVE LEARNING FACILITIES

After an extremely close second-attempt bond election ("One Vote Wonder!"), it was time to really get creative with our building projects. In order to accommodate the build of our new High School, teachers transitioned to a modified, alternate block schedule and students spent the 2022-2023 school year learning in a variety of creative locations across our community. Once the HS project phase was complete, it was time to start on construction and renovations for the Elementary School. We will share what worked, what had to be modified, and how our strong project partnerships resulted in success. Attend this session to not only learn about our construction project, but also how we used this exciting time to continue building support from our communities!

PRESENTER: Jeremy Christiansen & Dustin Thompson - Laurel-Concord-Coleridge; Steve Thiele & Ashley Abramson - Hausmann Construction; Bob Soukup - CWP Architects; Cody Wickham - D.A. Davidson

B

B - BREAKOUT SESSIONS THURSDAY, NOVEMBER 16 - 11:15 AM TO 12:15 PM



B1 THE NSAA IN ACTION

The NSAA will discuss the legislative process and current initiatives that support and assist NSAA member schools in day-to-day operations.

PRESENTER: Jennifer Schwartz – NSAA



B2 ONE DISTRICT'S CUSTOMIZED TIERED APPROACH TO SUPPORTING STUDENT AND STAFF MENTAL WELLNESS



The Ord Public Schools has a unique custom developed approach to supporting student and staff mental wellness by offering tiered levels of support. This includes three Guidance Counselors for the K-12 district, a contracted Licensed Mental Health Practitioner in district part-time, and unlimited counseling and wellness sessions both online and in-person through a contracted prepaid partnership with Wholeness Healing. The unlimited counseling available to all students and staff has been highly impactful with helping to support both students and staff that find themselves in need of support. We would like to share with other districts how we were able to achieve this financially, and with scheduling. This system has been four years in the making, but knowing what we know now, other districts can learn from our template and follow some well-designed steps to make it happen in their districts.

PRESENTER: Heather Nebesniak - Ord Public Schools



B3 HOW MUCH CAN I REALLY KNOW? PERSONNEL MATTERS FOR SCHOOL BOARDS



This session will walk through the Nebraska Teacher Tenure Act and discuss the board's role in a personnel matter.

PRESENTER: Josh Schauer & Greg Perry - Perry Law Firm



B4 EFFECTIVE STAKEHOLDER ENGAGEMENT

A high-quality education does not stop after the last bell. The best education uses all of the contributions of a wide variety of stakeholders to support students. Yet, how do we communicate the many different efforts of education to our stakeholders? Moreover, how do we build commitment from our community for district initiatives? Join the Board Leadership Team as we explore the effective engagement of stakeholders and how to build meaningful relationships between the district and community.

PRESENTERS: Marcia Herring, Caden Frank & Kari Stephens - NASB



B5 KSB GOES TO HOLLYWOOD: PUBLIC COMMENT IN ACTION!

Public comment, our favorite topic! What, exactly, is permissible? What does a patron have to disclose before speaking? Is repetition permitted? What if they want to talk about students or staff members--we can stop that, right? This session will be interactive and display the horrible acting chops of the attorneys from KSB. We'll actually demonstrate and talk through how we recommend boards and administrators handle tricky situations dealing with public comment at board meetings (and a few bonus scenes board members deal with all the time).

PRESENTERS: Bobby Truhe, Karen Haase, Steve Williams, Coady Pruett, Jordan Johnson & Sara Hento - KSB School Law



B6 LEAD NEBRASKA: LEADERSHIP DEVELOPMENT TO ADDRESS ED PIPELINE SHORTAGES FOR ADMINISTRATOR CANDIDATES



ESU 6, in partnership with UNL Educational Administration and NCSA, have implemented an innovative program to address Ed leadership shortage challenges. The grant focuses on developing teacher leaders and fostering readiness for pursuing educational leadership through Ed Ad program pathways. Content was delivered through a series of seminars focusing on foundational skills of school leadership. Learn how ESU 6 and UNL are partnering to promote the next generation of Nebraska Ed Leaders!

PRESENTERS: Scott Sturgeon & Nick Pace - UNL; John Skretta - ESU 6

THURSDAY BREAKOUT SESSIONS



B7 BOARD MEMBERS, SOCIAL MEDIA AND FREE SPEECH

Social media has become such a prevalent communication platform in today's society. Questions can and do arise with whether an elected public official's social media site is purely personal or has spilled over to the public domain. In this session, we will discuss some of these issues and how courts are addressing this. We will also discuss other communication media, including emails, text messages and the like.

PRESENTERS: Derek Aldridge & Josh Schauer - Perry Law Firm



B8 WOOD RIVER RURAL SCHOOLS RESPONDS TO HEALTH CARE WORKER DEMAND WITH CNA PROGRAM

To help meet demand for medical field workers, Wood River Rural Schools has established a Certified Nursing Assistant program. This was a collaboration with Central Community College, the Wood River community, and generous local donors. With this in-school opportunity, students are prepared for high demand, high pay, high skill careers in medical care. For those students who have a career interest in medicine, becoming a CNA gives them a valuable experience that opens many doors in their future. Join Shelby Allan, WRRSD School Nurse, plus past and current students as they discuss the ins and outs of this program.

PRESENTER: Shelby Allan & Terry Zessin - Wood River Rural Schools



B9 WHEN YOUR SCHOOL'S SAFETY IS UNDER ATTACK...WHAT I WISH I WOULD HAVE KNOWN PRIOR



We often say "it will never happen to us." We all have safety teams, crisis teams, and threat assessment teams...but things still happen. There is only so much the pieces of training and manuals can provide when a crisis strikes. This session will provide all the things I learned and wish I would have known prior to an incident that we all thought "would never happen to us."

PRESENTER: Stephanie Kaczor - Riverside Public Schools



B10 DIGITAL WISE PARENTING TO CREATE DIGITALLY FIT STUDENTS



What do adults need to be aware of when devices are a big part of children's lives? The core of many of the issues seen in schools originate from digital platforms, apps, and media. Exposure to digital nuances impact all of us on a behavioral, mental, and emotional level. Developing our digital wisdom will make us more mindful of the best practices to assist students with better digital: citizenship, literacy, privacy, and navigation within the virtual world to be safer and more secure in the real world. We will discuss: platform pressures, synthetic media, emotional exploitation, and digital fitness. Digital parent academies are needed to give them the tools to build a child's digital wisdom framework for safe platform participation.

PRESENTER: Jay Martin - NDE



LEARNERS LEADING LEARNERS

THURSDAY BREAKOUT SESSIONS

SUPERINTENDENT OF THE YEAR WILL BE RECOGNIZED AT THE THURSDAY LUNCHEON



Previous Winners Include:

2024 - ANDY RIKLI, PAPIILLION LA VISTA	2012 - BILL MOWINKEL, GRAND ISLAND NW	2000 - STEVE, JOEL, BEATRICE
2023 - MARK LENIHAN, WAYNE	2011 - MIKE CUNNING, HERSHEY	1999 - KENNETH ANDERSON, HASTINGS
2022 - TERRY HAACK, BENNINGTON	2010 - KEITH LUTZ, MILLARD	1998 - KEN BIRD, WESTSIDE
2021 - JIM SUTFIN, MILLARD	2009 - STEVE RECTOR, SOUTH SIOUX CITY	1997 - RICK BLACK, CONESTOGA
2020 - MARK ADLER, RALSTON	2008 - LARRY RAMAEKERS, AURORA	1996 - GARY HAMMACK, KEARNEY
2019 - MIKE TEAHON, GOTHENBURG	2007 - ROGER BREED, ELKHORN	1995 - MARTIN PETERSEN, ALLIANCE
2018 - JOHN SKRETTA, NORRIS	2006 - RICHARD EISENHAUER, LEXINGTON	1994 - VANDLE PHILLIPS, SOUTH SIOUX CITY
2017 - CAROLINE WINCHESTER, CHADRON	2005 - ROY BAKER, NORRIS	1993 - FRED BELLUM, COLUMBUS
2016 - JAY BELLAR, BATTLE CREEK	2004 - DAN ERNST, WAVERLY	1992 - GLENN LARSEN, ADAMS CENTRAL
2015 - BRIAN MAHER, KEARNEY	2003 - RANDY NELSON, NORFOLK	1991 - NORBERT SCHUERMAN, OMAHA
2014 - STEVE BAKER, ELKHORN	2002 - PHILIP SCHOO, LINCOLN	1990 - DOUG CHRISTENSEN, NORTH PLATTE
2013 - KEVIN RILEY, GRETNA	2001 - KEITH ROHWER, NEBRASKA CITY	1989 - DONALD STROH, MILLARD



C - BREAKOUT SESSIONS THURSDAY, NOVEMBER 16 - 2:15 TO 3:15 PM



C1 STUDENT VOICES

Students from Nebraska high schools share their perspectives on issues that are important to the leaders of tomorrow.



C2 ADDRESSING DIVERSE POPULATIONS IN RURAL DISTRICTS TO ENSURE QUALITY EDUCATION IN GRADES PK-12



Lexington Public Schools will share how it is addressing the needs of the whole child in a rural district with a diverse population and student needs. From programs that support EL/Migrant populations to students experiencing poverty and trauma, LPS representatives will share some of the programs and approaches they have implemented to ensure all students are prepared to learn and succeed.

PRESENTERS: John Hakonson, Angie Kovarik, Annette Fitzgerald - Lexington Public Schools



C3 ATHLETICS, ACTIVITIES, AND THE LAW

School athletics and activities present unique legal challenges. From name image and likeness (NIL) to transgender participation, these are hot button issues that impact all schools. In this session, we will discuss those matters along with important topics such as Title IX, booster club funds, and activities discipline. These are emerging areas of the law that are constantly impacted by court decisions and legislative activities, and it is important to stay ahead of the game (pun intended) on these topics.

PRESENTERS: Josh Schauer & Derek Aldridge - Perry Law Firm



C4 WALKING ALONGSIDE THE BOARD THROUGH SUPERINTENDENT EVALUATION AND BOARD SELF-ASSESSMENT

Evaluating the superintendent is one of the primary functions of the board. Eliminate the obstacles that distract the board from administering an efficient and effective evaluation process. Are you allowing the superintendent to complete a self-assessment and do all board members participate in the evaluation of the superintendent? Join us to discuss the importance of the evaluation tool, protocols, and procedures for administering a fair and professional evaluation, plus adoption of goals to support superintendent accountability for growth of the district and his/her professional leadership.

PRESENTERS: Marcia Herring & Katie Corfield - NASB

TO REGISTER FOR THE CONFERENCE VISIT WWW.NASBONLINE.ORG



C5 PERSONNEL MATTERS: FACT, FICTION, AND FUNCTION

Quality staff members make all the difference, and boards and administrators appropriately spend a lot of time, energy, and money ensuring students receive a top-notch education from excellent educators. It doesn't always work out that each educator is a fit for each school, and vice-versa. This presentation will make sure everyone understands their role and responsibilities during personnel cases, from the evaluation process through the school board hearing, focusing on key elements that prove difficult or frustrating every time. Whether you've been through it or not, there's always more to know!

PRESENTERS: Karen Haase, Steve Williams & Jordan Johnson - KSB School Law



C6 RETAINING & HIRING MUSIC TEACHERS IN SMALL SCHOOLS

Music education is an integral part of a student's physical, mental, and emotional health. There is a concern across the state that small schools (especially those in more rural areas) are not filling their music positions. NSBA (Nebraska State Bandmasters Association), along with some administrators from across the state are going to share the efforts that are being made to prevent their small schools from being a "stepping stone" job and instead make it a "forever" job where their music teacher(s) can build a program and have a desire to stay.

PRESENTERS: Emiley Bond - Nebraska State Bandmaster Association; Anna Sake - Palmer Public Schools



C7 WHAT HAPPENS IN CLOSED SESSION, STAYS IN CLOSED SESSION?

Closed session can be a very complicated area of the law. In this session, we will walk through the legal requirements and case studies involving entering into closed session, discussions during closed session, "leaks" from closed session, and other legal and practical issues that may arise during (or after) closed session. We will also discuss how to make the proper motion to enter into closed session, how to exit closed session, and how closed session entrance and exit should appear in minutes.

PRESENTER: Justin Knight - Perry Law Firm



C8 REFRAMING THE FOUR-DAY WEEK DEBATE: STUDENT ENRICHMENT AND SUPPORTING THE PROFESSION

The move to a four-day school week and implementation of Optional Enrichment Fridays has realized some positive outcomes for both students and teachers! Our district's innovative approach to providing enrichment opportunities for students, meeting the needs of families, and tackling dwindling enrollment is now in its fifth year. This session provides an overview of implementing a radical change through the lenses of current research, community consultation, student engagement, and district leadership. The lessons learned in the process and plans for the future will be presented.

PRESENTER: Evelyn Browne - Banner County School



C9 LIKE FREE, BUT STILL HIGH QUALITY?

The current reality in education is; tight budgets, staff shortages, unfunded mandates, and expensive materials. ESU 5 has looked at Open Education Resources (materials FREELY available online). We have vetted these units for quality and have put together a coherent K-12 science curriculum from these FREE units. Most of our units are already ranked "high quality." Interested in getting access to our FREE, vetted curriculum for your school? Come to this session and you will leave with FREE access to the units we have collected as well as our suggested scope and sequence for implementation.

PRESENTER: Annette Weise - ESU 5



C10 ESU BOARD MEMBER UPDATE

Attend this session for a review of events from the past year and a preview of the programs of interest to ESUs across the state.

MODERATOR: Jim Luebbe - NASB

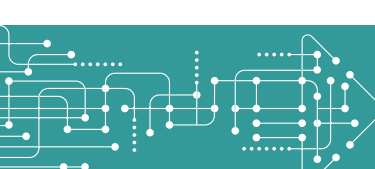

D

D - BREAKOUT SESSIONS THURSDAY, NOVEMBER 16 - 3:30 TO 4:30 PM



D1 WHO WILL BE YOUR DISTRICT'S NEXT SUPERINTENDENT?

Are you concerned about hiring a high-quality superintendent should your current superintendent resign? If so, then the Nebraska Association of Professors of School Leadership (NAPSL) would like to partner with you in developing solutions that will ensure future high-quality leaders for our Nebraska schools. During this session, NAPSL will facilitate conversations focused on Nebraska school leaders. The session will review Nebraska's history of superintendents along with examining how future Nebraska superintendents must be more diverse to keep up with demand. Board members and superintendents are encouraged to attend.

PRESENTERS: Michael Sieh - Wayne State College; Kevin Riley - UNO; Shavonna Holman - UNL



D2 EHA BENEFITS UPDATE

Overview of the health and dental plans available to EHA schools, member engagement programs, and an opportunity to address your benefit questions.

PRESENTERS: Brett Young - BCBS; Greg Long - EHA



D3 SCHOOL LAW JEOPARDY FOR BOARD PRESIDENTS

This session is targeted to current and aspiring school board presidents. From preparing agendas, managing public comment, and serving as the "chair" of the board, we will walk through a board president's legal "dos" and "donts."

PRESENTER: Justin Knight & Josh Schauer - Perry Law Firm



D4 DIGITIZING AND STREAMLINING YOUR BOARD MEETINGS AND STAFF NEGOTIATIONS

The days of using paper and manual calculations are slowly coming to an end. In this session, you will learn the features and benefits of the Sparq Meetings and Negotiations platforms; some of our tips and tricks for becoming more proficient and efficient; and what new changes have been added that make your life easier.

PRESENTERS: Nicole Kobus & Darion Miller - Sparq Data Solutions



D5 DUELING PIANOS, SCHOOL LAW STYLE

You've got the requests; they've got the keys. Jim and Karen will have some pre-planned topics to cover, and then they will open it up for requests! From personnel/student issues to the First Amendment, anything goes. Bring your questions and requests, and Karen and Jim will keep it 100 (or at least PG-13).

PRESENTERS: Jim Gessford - Perry Law Firm; Karen Haase - KSB School Law



D6 WHY DO SCHOOL BOARDS NEED TO PAY ATTENTION TO BIRTH TO FIVE?

You can't care about children's reading proficiency, academic success, and high school graduation rates without caring about quality early childhood education. The foundation for all future learning is built during children's earliest years. Yet, Nebraska does not have enough programs. Get insights from a new survey that shows Nebraska voters want early education supported like K-12 and higher education. Hear from school leaders about how they are leveraging funding sources and partnerships to build a birth-through-third grade continuum. Also learn how We Care for Kids can help.

PRESENTER: Kara Ficke - We Care For Kids



D7 HELPING HANDS

The North Platte Public School district's Helping Hands program is designed to have one college-aged student come into the classroom to serve as a positive mentor/role model to students with behavior needs. The Helper will support the student in the classroom by helping to keep the student on task, assist the student with coping skills, follow and implement Behavior Improvement Plans, and help identify the good things the student does during their time with them. The college students have received training from local Licensed Mental Health Providers.

PRESENTERS: Todd Rhodes & Brandy Buscher - North Platte Public Schools

FRIDAY BREAKOUT SESSIONS



CLASSROOM SHOWCASE FRIDAY, NOVEMBER 17 - 8:00 TO 11:30 AM



NASB DELEGATE ASSEMBLY FRIDAY, NOVEMBER 17 - 8:00 TO 9:30 AM



NASA MEMBERSHIP MEETING FRIDAY, NOVEMBER 17 - 8:00 TO 9:30 AM



E - BREAKOUT SESSIONS FRIDAY, NOVEMBER 17 - 9:15 TO 10:15 AM



E1 LOCAL VETERANS' HISTORY PROJECT

The Congressional Veterans History Project 2000 was designed to record the memories of WWII Veterans across the Nation. Unfortunately, most schools are still unfamiliar with this project and these memories are lost. Using the interview questionnaire from the CVHP our High School has interviewed around 60 area veterans who served in WWII to the present day. What we have learned is our students and veterans develop a unique relationship and learning opportunity. Students develop these skills: organizing, greeting, interviewing, listening, recording, writing, summarizing, and thanking. Skills that reach across the curriculum. Veterans benefit by seeing our community's youth being attentive and appreciative of the sacrifices service requires.

PRESENTERS: Lance Swanson - South Sioux City Community Schools; Dwight Freiberg & Steve Shadle - Siouxland Freedom Park



E2 BOARD COMMITTEES - HOW TO EFFECTIVELY UTILIZE COMMITTEES

One Board's journey from near non-existent committee meetings to routine committee meeting utilization. Learn about the effect on board cohesiveness and communication, Board/Superintendent relations, community engagement and the evolution to more effective and efficient Board meetings.

PRESENTER: Alicia Beavers - Elm Creek Public Schools



E3 HOT TOPICS IN SCHOOL CONSTRUCTION AND FINANCING

In this session, we will discuss some of the basics of the statutory requirements for school districts contemplating facility construction projects. We will also discuss considerations of financing, including bond issue elections, assistance in this approach for school districts and the dos and don'ts for school districts. Finally, we will discuss some pitfalls that can occur in school construction.

PRESENTER: Derek Aldridge - Perry Law Firm

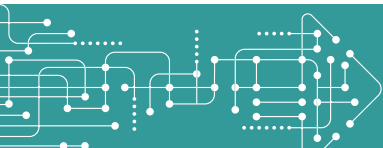



E4 ACCESS TO OVERALL WELL-BEING



ESU 2 Team ACCESS (All Children Celebrated Educated Safe & Successful) is a program to support students, families, and districts by expanding services and programs that aim to address overall well-being. Team Access was created as a single entry point for our school districts to access our social support services. Our goal is to work together behind the scenes, to make it easier for schools to navigate our many social support programs. The presentation will review how ESU 2 Team ACCESS staff help coordinate services, provide educator training, and support through small group instruction or mental health counseling.

PRESENTERS: Taira Masek & Megan Reese - ESU 2



E5 PAIN IN THE APP, V. 9.0

It's hard to believe it, but this annual favorite is now a 3rd grader! We will take board members and administrators through the most relevant and recent cases with information related to the intersection of schools and student use of technology and social media.

PRESENTERS: Karen Haase & Sara Hento - KSB School Law



E6 RECOGNITION: IT'S MORE THAN JUST A THANK YOU

Workplace wellbeing is a hot topic in many school districts. Terms such as "self-care" are casually thrown around, but what is the right way to show meaningful appreciation to staff members? According to a recent Gallup survey, only 31% of U.S. teachers report feeling engaged at work. This means, almost 70% of teachers are going to work burned out or feeling depleted. In this session, attendees will learn the best practices in workplace recognition, strengths-based leadership, and engagement.

PRESENTER: Hannah Miller - TeamMates Mentoring



E7 ARTIFICIAL INTELLIGENCE (AI) & REMOTE LEARNING ISSUES - WHERE ARE WE HEADED?

Social media and Artificial Intelligence (AI) technology are changing the global framework of public education at a faster pace than ever before in history. From AI software programs designed to modify instructional delivery to meet each individual student's needs, to now, students using AI to complete their homework. Are we set for teacher email signature lines like "I'm teleworking on Mondays and Wednesdays," now common place in the private sector? We will explore the parameters of where public education is heading.

PRESENTERS: Jim Gessford & Justin Knight - Perry Law Firm



E8 MISSION: MENTAL HEALTH

Mission: Mental Health is an original mental health initiative that was implemented at Lakeview Community Schools during the school year. Administrators and school counselors worked together to create this initiative to help prevent staff burnout and boost staff morale throughout the district. The initiative provided quarterly incentivized challenges to help staff members focus on taking care of themselves, checking in on their coworkers, and bringing awareness to mental health. The initiative was supported by community businesses with donations as incentives for staff. Mission: Mental Health was positively viewed by staff members, improved culture, and promoted mental health wellness.

PRESENTERS: Aaron Plas - Bennington Public Schools; Mollie Rambour, Paige Rambour & Miranda Hellbusch - Lakeview Community Schools



F

F - BREAKOUT SESSIONS FRIDAY, NOVEMBER 17 - 10:30 TO 11:30 AM



F1 WELLNESS 4ALL MENTAL HEALTH PROGRAM

Attendees will learn about the impactful Wellness 4ALL mental health program that began in 2017 at Educational Service Unit 5 (ESU5). Fast forward six years, the program supports all 10 districts in ESU5, and an additional three districts outside of ESU5.

PRESENTERS: Jen McNally, Brenda McNiff & Jamie Mapp - ESU 5



F2 ADDRESSING THE SUBSTITUTE TEACHER SHORTAGE, SERVING DIVERSE LEARNERS

Since December 2020, Central Community College has helped metro and rural schools address the critical substitute teacher shortage. Come and learn how CCC quickly responded by creating an accessible, engaging, informative human relations course. More than just a training, the course's design helps students gain a basic understanding of cultures' contributions to our pluralistic society as well as provide beginning strategies to advocate for human dignity and individual rights. Presenters will share a course outline and student stories of growth. The course is offered most every month and has been delivered to over 1,500 students and substitute candidates.

PRESENTER: Abie Ott - Central Community College



F3 NEGOTIATIONS FOR BOARD MEMBERS

Negotiations is one of the most important functions of a school board. In fact, "personnel" is the largest item of a school district's budget. This session will walk through the statutory requirements for negotiations. We will also give boards an update on negotiations "hot topics" and ideas for the 2023-2024 negotiations season.

PRESENTER: Justin Knight - Perry Law Firm



F4 CHECKING THE PULSE OF YOUR DISTRICT

Over the past 3 years education has changed. Boards, administrators, teachers, and students have handled situations and issues no one thought possible. So how is your district doing? How are you: Board Member? Superintendent? How are your Administrators? Staff Members? Students? Research shows that engaging all stakeholders is one way to "check the pulse of the district," grow student success, keep teachers, and gauge well-being of the school district. This session will address the importance of stakeholder engagement to help districts continue to better their climate and culture and grow student success.

PRESENTERS: Kari Stephens & Marcia Herring - NASB



F5 PICKING YOUR OWN CONTRACTOR

Do you have a new construction project or a large renovation coming up? Do you need some construction management input before finalizing your design? Do you want the opportunity to select your construction manager based on experience and quality rather than just the lowest responsible bidder? Steve Williams and Coady Pruett will discuss the construction management at risk option for school districts, including when you can use a CM, the selection process, advantages, and how to avoid pitfalls. Any school board members or administrators who are thinking about an upcoming construction project or renovation should attend this session.

PRESENTERS: Steve Williams & Coady Pruett - KSB School Law



F6 ORIENTATION AND MENTORING...STARTING OFF ON THE RIGHT FOOT

As board members, new or old, are there expectations for you as a board member that have been shared by board leadership or by the superintendent/administrator? Do you know where to access policies, staff information, board meeting minutes/agendas? Is there training you need to attend? What are the goals of the board? This session will provide a practical template for Board Orientation and Mentoring for school district or ESU boards. Please join us for this practical learning session, to enhance your school board member onboarding process.

PRESENTER: Larianne Polk - ESU 7

FRIDAY BREAKOUT SESSIONS



F7 WE DON'T HAVE A POLICY ON TRANSGENDER STUDENTS, BUT SHOULD WE?

The law and guidance surrounding transgender students is changing faster than ever before. In this presentation, attorneys from the Perry Law Firm will address the current status of the law concerning transgender students and will address when, if ever, your board should consider adopting a policy regarding the rights and privileges of transgender students.

PRESENTERS: Greg Perry & Haleigh Carlson - Perry Law Firm



F8 A LISTENING SESSION WITH MEMBERS OF THE STATE BOARD OF EDUCATION

Share your thoughts on statewide education policy with members of the State Board of Education. State Board members are particularly interested in what is currently affecting local school boards and districts, and the solutions you have to offer for these issues. Topics may include school accountability, accreditation, and approval; educator certification; and statewide assessment, among others. Attending this session is a great opportunity for you to have your voice heard among members of the State Board of Education.

PRESENTERS: Ryan Foor - NDE; Patti Gubbels - State Board of Education



ANN MACTIER - SCHOOL BOARD MEMBER OF THE YEAR WILL BE PRESENTED AT THE FRIDAY LUNCHEON

Previous Winners Include:

2022 - MARCIA MAHON, SOUTH SIOUX CITY
2021 - STEVE KOCH, HERSHEY
2020 - MARIAN HOLSTEIN, WINNEBAGO
2019 - VALERIE FISHER, PAPPILLON-LA VISTA
2018 - KATHY DANER, LINCOLN
2017 - BONNIE HINKLE, GRAND ISLAND
2016 - TERRI HAYNES, CHADRON

2015 - LINDA RICHARDS, RALSTON
2014 - BRAD KRIVOHLAVEK, NORFOLK
2013 - PATTY BENTZINGER, NORRIS
2012 - KATHY BARTEK, FALLS CITY
2011 - JULIE AGARD, KEARNEY
2010 - KIM FASSE, ELKHORN
2009 - RON PEARSON, ESU #3

2008 - SANDRA JENSEN, OMAHA
2007 - JOHN HANSEN, BELLEVUE
2006 - FRED TAFOYA, PAPPILLON-LA VISTA
2005 - WAYNE ERICKSON, WISNER-PILGER
2004 - ANN MACTIER, OMAHA

REGISTERING FOR THE CONFERENCE

REGISTRATION FOR THE 2023 STATE EDUCATION CONFERENCE WILL OPEN WEDNESDAY, SEPTEMBER 13, 2023

To register, go to the NASB website at www.NASBonline.org and log in using your email and password, and click the State Education Conference link.

AS YOU REGISTER, BE SURE TO MAKE PLANS TO ATTEND THE EXHIBITOR RECEPTION FROM 4:00 TO 5:30 PM ON WEDNESDAY, NOVEMBER 15. IF YOU HAVE SPECIAL DIETARY NEEDS DUE TO A MEDICAL CONDITION, CONTACT ABI CARLSON AT 800-422-4572 TO ARRANGE ALTERNATIVE MENUS.



TO REGISTER FOR THE CONFERENCE VISIT WWW.NASBONLINE.ORG



1311 STOCKWELL STREET
LINCOLN, NE 68502
WWW.NASBONLINE.ORG

RETURN SERVICE REQUESTED

2023 STATE EDUCATION CONFERENCE
NOVEMBER 15-17
CHI HEALTH CENTER - DOWNTOWN OMAHA

LEARNERS LEADING LEARNERS



Co-Sponsored by the Nebraska Association of School Boards
and the Nebraska Association of School Administrators

