



LINCOLNWOOD SCHOOL DISTRICT 74  
BOARD OF EDUCATION  
FACILITIES COMMITTEE MEETING AGENDA  
TUESDAY, MARCH 16, 2021 AT **6:00 PM**

BOARD OF EDUCATION  
**Scott L. Anderson**, *President*  
**Kevin Daly**, *Vice President*  
**John P. Vranas**, *Secretary*  
**Jeffrey S. Evens**  
**Myra A. Foutris**  
**Elaina Geraghty**  
**Rupal Shah Mandal**

ADMINISTRATION  
**Dr. Kimberly A. Nasshan**, *Superintendent of Schools*  
**Dr. David Russo**, *Assistant Superintendent for Curriculum and Instruction*  
**Courtney Whited**, *Business Manager/CSBO*

*Agenda of the Facilities Committee Meeting of the Board of Education of Lincolnwood School District 74,  
Cook County, Illinois, to be held in the Lincoln Hall Band Room #108  
6855 North Crawford  
Lincolnwood, IL 60712,  
on Tuesday, March 16, 2021.*

The February 16, 2021 Facilities Committee meeting was cancelled due to light agenda.

IN-PERSON PARTICIPATION: It is expected that all members of the Facilities Committee, plus several administrators, will be physically present in the Lincoln Hall Band Room (#108) located at 6855 North Crawford, Lincolnwood, IL. The March 16, 2021 Facilities Committee meeting will be broadcast through ZOOM Video Conferencing for Public Audience to Visitors. Members of the public are encouraged to utilize the Zoom broadcast if possible. Zoom Tech Check at 5:45 p.m.

Join the meeting via ZOOM app (video and audio): Meeting ID: # 856 7668 4298  
(Link: <https://sd74-org.zoom.us/j/85676684298>)

or

Join the meeting via phone (audio only): Step #1: Dial 1-312-626-6799; Step #2: Enter Meeting ID: # 856 7668 4298

1. CALL TO ORDER/ROLL CALL

FACILITIES COMMITTEE MEMBERS

John P. Vranas (BOE), Chairman

Elaina Geraghty (BOE)

Rupal Shah Mandal (BOE)

Joe Ehrenberg, Community Member

Emily McCall, Community Member

Zade Tagani, Community Member

ADMINISTRATORS/STAFF

Dr. Kimberly A. Nasshan, Superintendent of Schools

Dr. David L. Russo, Assistant Superintendent of Curriculum and Instruction

Courtney Whited, Business Manager/CSBO

Jim Caldwell, Director of Buildings and Grounds

2. AUDIENCE TO VISITORS

3. APPROVAL OF MINUTES

a. Facilities Committee Meeting Minutes - **January 19, 2021**

Motion by member: \_\_\_\_\_ Seconded by: \_\_\_\_\_

4. DISTRICT ARCHITECT OF RECORD - STUDIUGC architecture+interiors

a. INFORMATION/DISCUSSION: StudioGC Presents Options for Grade 5 and Specials Furniture at Rutledge Hall

5. OLD BUSINESS

6. NEW BUSINESS

- a. INFORMATION/DISCUSSION: Ascent© Control Module Upgrade and Data Communication Wiring at Lincoln Hall
  - b. INFORMATION/DISCUSSION: Lincoln Hall HVAC Hot Water Piping
  - c. INFORMATION/DISCUSSION: Drinking Fountains/Bottle Fillers
7. INFORMATION/DISCUSSION: District Facilities Update(s)
8. ADJOURNMENT

Motion by Member: \_\_\_\_\_ Seconded by: \_\_\_\_\_

**Dr. Kimberly A. Nasshan, Superintendent of Schools**

*Lincolnwood School District 74 is subject to the requirements of the Americans with Disabilities Act of 1990. Individuals with disabilities who plan to attend this meeting and who require certain accommodations in order to allow them to observe and/or participate in this meeting, or who have questions regarding the accessibility of this meeting or facility, are requested to contact the District Office at 847-675-8234 promptly to allow Lincolnwood School District 74 to make reasonable accommodations for those persons.*

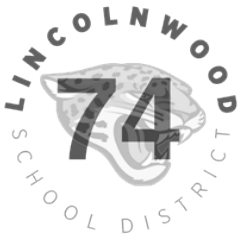

LINCOLNWOOD SCHOOL DISTRICT 74  
BOARD OF EDUCATION  
FACILITIES COMMITTEE MEETING MINUTES  
TUESDAY, JANUARY 19, 2021 AT **6:00 PM**

BOARD OF EDUCATION  
Scott L. Anderson, *President*  
Kevin Daly, *Vice President*  
John P. Vranas, *Secretary*  
Jeffrey S. Evens  
Myra A. Fourtris  
Elaina Geraghty  
Rupal Shah Mandal

ADMINISTRATION  
Dr. Kimberly A. Nasshan, *Superintendent of Schools*  
Dr. David Russo, *Assistant Superintendent for Curriculum and Instruction*  
Courtney Whited, *Business Manager/CSBO*

*Minutes of the Facilities Committee Meeting of the Board of Education of Lincolnwood School District 74,  
Cook County, Illinois, was held in the Lincoln Hall Auditorium  
6855 North Crawford  
Lincolnwood, IL 60712,  
on Tuesday, January 19, 2021.*

1. CALL TO ORDER/ROLL CALL

Chairman Vranas called the Facilities Committee meeting to order at 6:01 p.m.

FACILITIES COMMITTEE MEMBERS

John P. Vranas (BOE), Chairman  
Elaina Geraghty (BOE)  
Rupal Shah Mandal (BOE)  
Zade Tagani, Community Member

FACILITIES COMMITTEE MEMBERS NOT PRESENT

Joe Ehrenberg, Community Member

OTHER BOARD MEMBERS PRESENT

Scott L. Anderson (BOE)

ADMINISTRATORS/STAFF

Dr. Kimberly A. Nasshan, Superintendent of Schools  
Dr. David L. Russo, Assistant Superintendent of Curriculum and Instruction  
Courtney Whited, Business Manager/CSBO (via zoom)  
Jim Caldwell, Director of Buildings and Grounds

OTHERS PRESENT

Athi Toufexis, StudioGC  
Pat Callahan, StudioGC (via zoom)

2. AUDIENCE TO VISITORS

None

3. APPROVAL OF MINUTES

a. Facilities Committee Meeting Minutes - **November 19, 2020**

A motion was made, seconded and passed to approve the November 19, 2020 Facilities Committee meeting minutes.

4. DISTRICT ARCHITECT OF RECORD - STUDIOGC architecture+interiors

a. Rutledge Hall Stairwell Flooring Bid

Athi Toufexis, StudioGC, presented the rubric for the Rutledge Hall Stairwell Flooring Bid. The irregularities in each bid were discussed.

Member Geraghty recused herself from all discussions and voting regarding the Rutledge Hall Flooring Bid.

A motion was made, seconded and passed that the Facilities Committee concur with the Administration's recommendation to the Board of Education to accept the bid from Johnson Floor Company in the amount of \$88,540 for the Rutledge Hall Stairwell Flooring project to begin and finish during the Summer 2021.

b. Todd Hall and Rutledge Hall Doors

Athi Toufexis, StudioGC, presented the rubric for the Todd Hall and Rutledge Hall Doors. The Committee discussed the bids submitted.

A motion was made, seconded and passed that the Facilities Committee concur with the Administration's recommendation to the Board of Education to accept the bid from Stuckey Construction Company with Alternate #1 in the amount of \$820,643 for the purpose of completing Health Life Safety interior and exterior door work at Todd Hall and Rutledge Hall during the summer of 2021.

5. OLD BUSINESS

None

6. NEW BUSINESS

None

a. Amendment No. 2 to Performance Contracting Agreement

Courtney Whited, Business Manager/CSBO, presented the Amendment No. 2 to Performance Contracting Agreement.

A motion was made, seconded and passed that the Facilities Committee concur with the Administration's recommendation to the Board of Education to approve the Performance Assurance Service Program cancellation by signing Amendment No. 2 to the Performance Contracting Agreement with Siemens.

b. Baseball Fields Dressing

Courtney Whited, Business Manager/CSBO, explained the costs associated with dressing the fields after the drainage project was completed last summer.

A motion was made, seconded and passed that the Facilities Committee concur with the Administration's recommendation to the Board of Education to accept the agreement from Sportsfields, Inc. for field dressing services using Mid Lo mix in the amount of \$26,850.

7. District Facilities Update

1. Rutledge Hall Small Group Instruction Room is in the punch list stage. The Committee directed StudioGC to start assessing liquidated damages if the project was not complete by January 29, 2021.
2. The Landscaping bid will be opened on January 25, 2021. Two vendors have toured the campus as required in the bid. The District sent out this RFP to a half dozen vendors and it was also posted in the newspaper. The District has received three inquiries and two vendors have surveyed the campus to date.

3. The Todd Hall Plaza Lighting has been completed.

8. ADJOURNMENT

A motion was made, seconded and passed to adjourn the Facilities Committee meeting at 6:28 p.m.  
The next Facilities Committee meeting will be held Tuesday, February 16, 2021 at 6:00 p.m. The public is welcome.

---

John P. Vranas, Chairman

---

Elaina Geraghty, Member

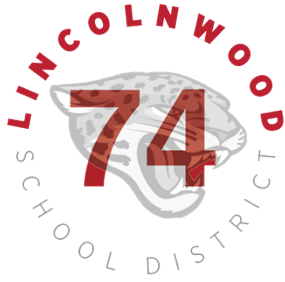

## Executive Summary Facilities Committee Meeting

DATE: March 16, 2021

TOPIC: StudioGC Presents Options for Grade 5 and Specials Furniture at Rutledge Hall

PREPARED BY: Courtney Whited

### **Recommended for:**

- Action
- Discussion
- Information

### **Purpose/Background:**

The District is approaching a third summer of facilities work guided by StudioGC. During the two previous summers, grade 3 and grade 4 classroom furniture was replaced. New furniture for grade 5 and special classes is scheduled for the upcoming summer. While most of the selections will match the established standard, there are some options to discuss for areas in need of unique pieces.

### **Fiscal Impact:**

\$242,900 was the estimate

The final pricing will likely be less than \$200,000

### **Recommendation:**

This summary is for informational purposes. The Administration requests direction from the Facilities Committee relative to selections for the upcoming summer 2021 furniture project. Final pricing will be reviewed for approval during a future Facilities Committee.

# Rutledge Hall 5th Grade & Small Group Room

Furniture Review

Drafted: March 8, 2021

Presented: March 16, 2021

**STUDIO GC**  
architecture + interiors



**SCOPE OF WORK**

- Summer 2021 Work
- Summer 2022 Work
- Summer 2022 Work: Requested Add



**SCOPE OF WORK**

-  Summer 2021 Work
-  Summer 2022 Work
-  Summer 2022 Work: Requested Add

# SECOND FLOOR: FURNITURE PLAN

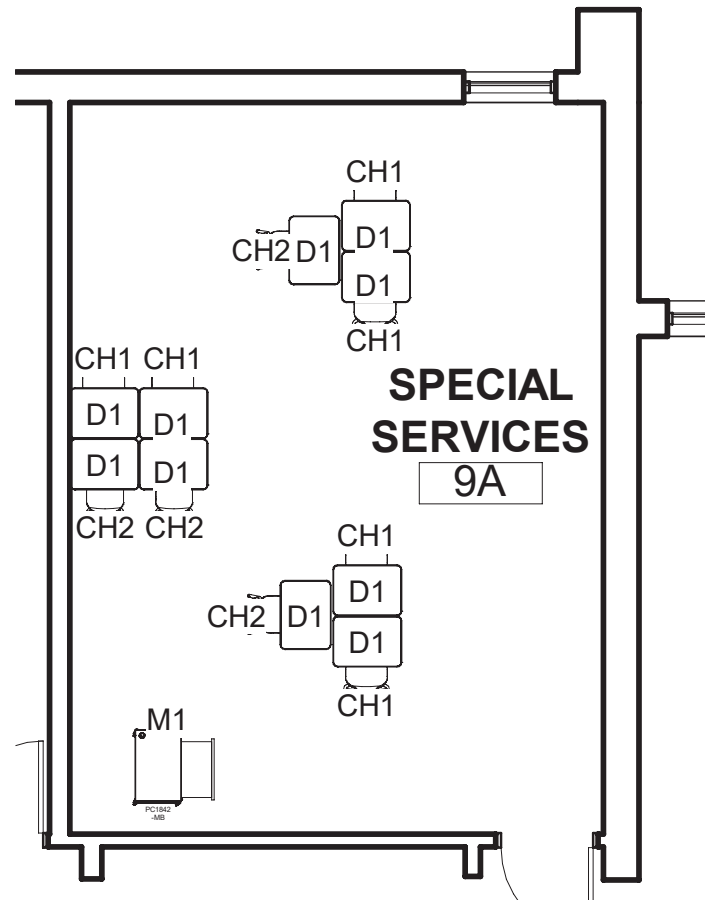

\*Using both 16" and 18" chairs for 3rd, 4th, and 5th grade use.\*



**D1:** Smith Systems - Silhouette  
Quantity: 10



**CH1:** Smith Systems - Flavors 18"H  
Quantity: 6  
Est. Price: \$96



Existing Student Desks and Chairs



**CH2:** Smith Systems - Flavors 16"H  
Quantity: 4  
Est. Price: \$89



**M1:** Media Technologies - Stowaway Lectern  
Quantity: 1

FIRST FLOOR: SPECIAL SERVICES 9A (ROOMS: EL 9B & EL 15 SIMILAR)

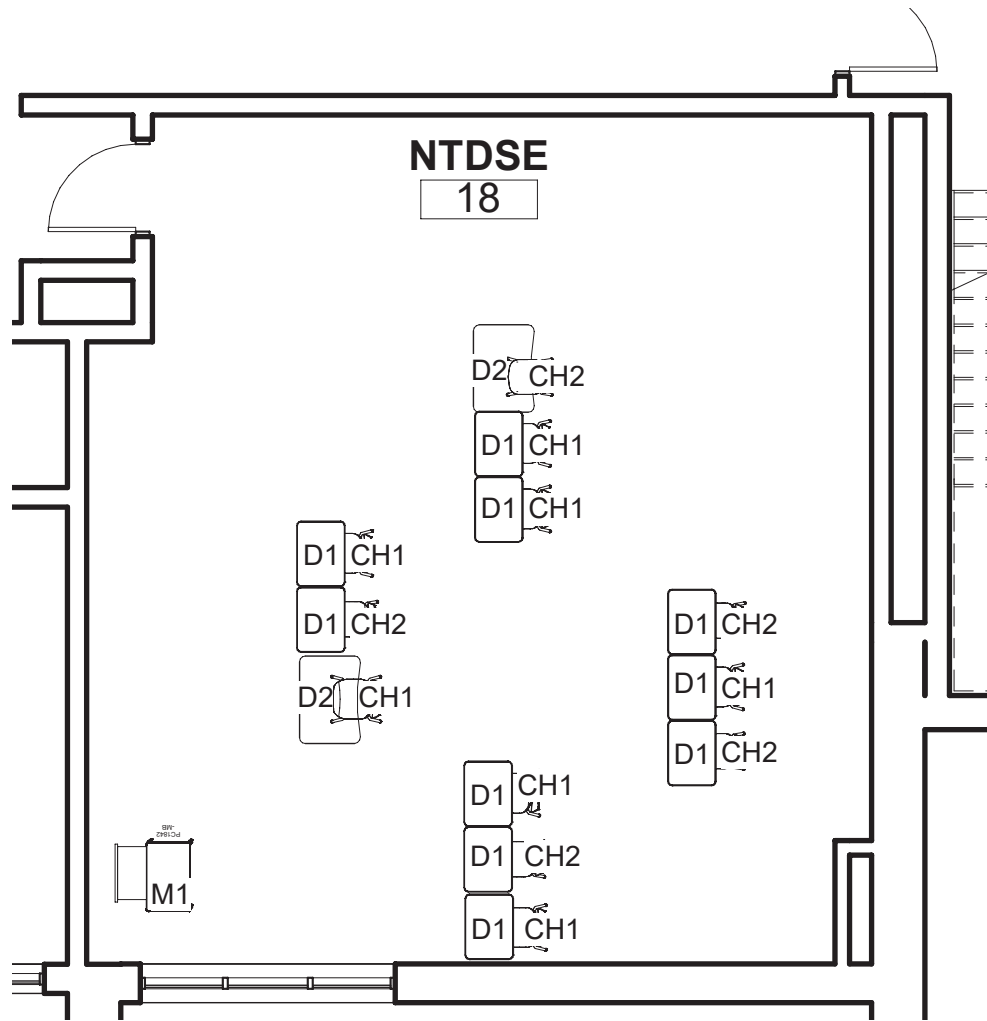

\*Using both 16" and 18" chairs for 3rd, 4th, and 5th grade use.\*



Existing Student Desks and Chairs



**D1:** Smith Systems - Silhouette  
Quantity: 10



**D2:** KI - ADA Ruckus Cantilever  
Quantity: 2



**CH2:** Smith Systems - Flavors 16"H  
Quantity: 5



**CH1:** Smith Systems - Flavors 18"H  
Quantity: 7



**M1:** Media Technologies -  
Stowaway Lectern  
Quantity: 1

FIRST FLOOR: NTDSE 18

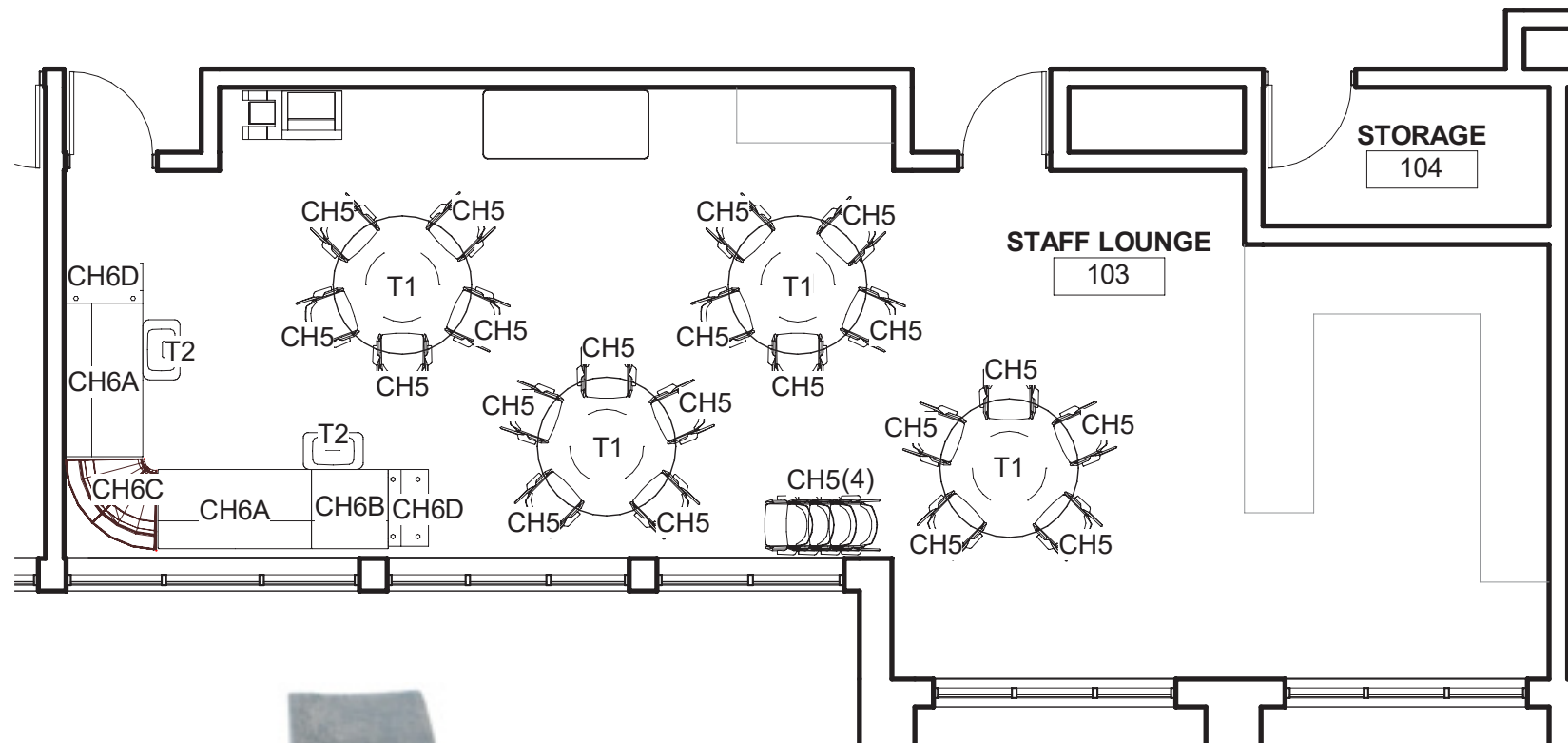

Steelcase: Campfire Lounge - Big (**CH6A**), Half (**CH6B**), 90 Inside Corner (**CH6C**), Wedge (**CH6D**)  
 Quantity: 2 (**CH6A**), 1 (**CH6B**), 1 (**CH6C**), 2 (**CH6D**)



**CH5:** KI - Doni Chair  
 Quantity: 24



**T1:** KI - Athens Table  
 Quantity: 5



**T2:** Steelcase - Simple Personal Table  
 Quantity: 2

**FIRST FLOOR: STAFF LOUNGE 103**



**OPTION 1**

Steelcase: Campfire Lounge  
Est. Price: \$8,000 (Plan Configuration)



**OPTION 2**

KI: MyWay Modular Lounge  
Est. Price: \$8,000

**STAFF LOUNGE: LOUNGE OPTIONS**

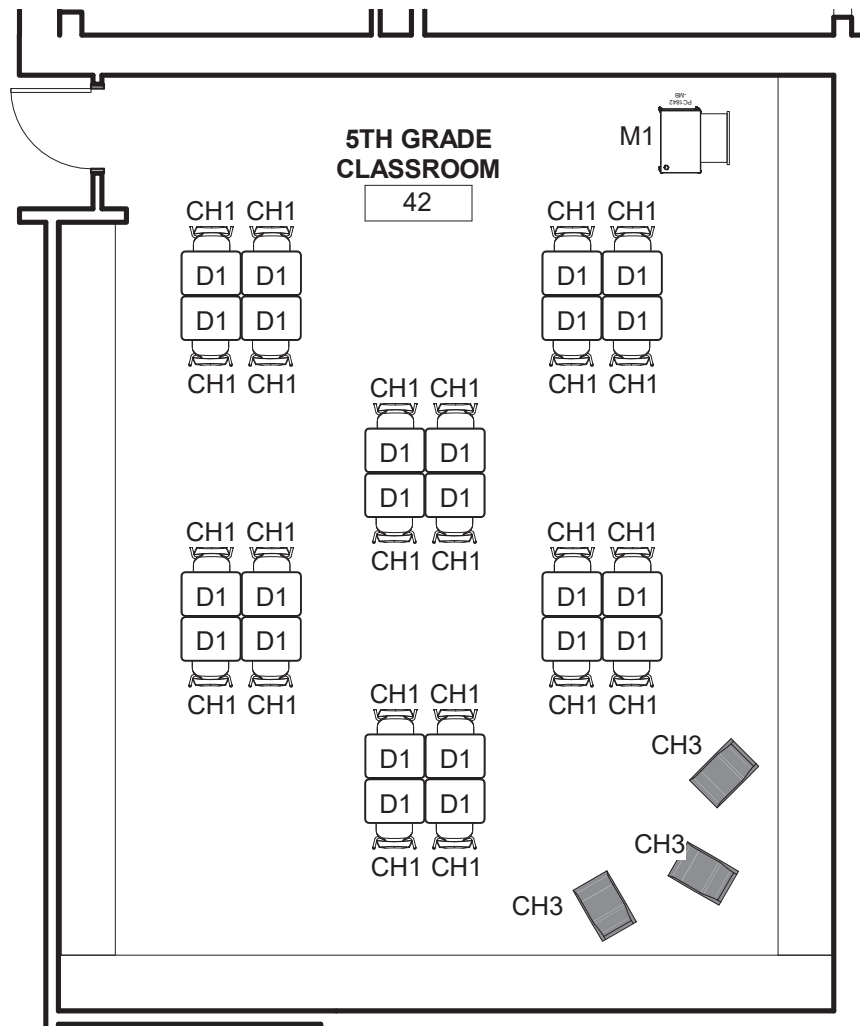

\*Using 18" chairs for 5th grade use.\*



Laminate:  
Classic Linen  
Edge:  
Persian Blue

**D1:** Smith Systems - Silhouette  
Quantity: 24

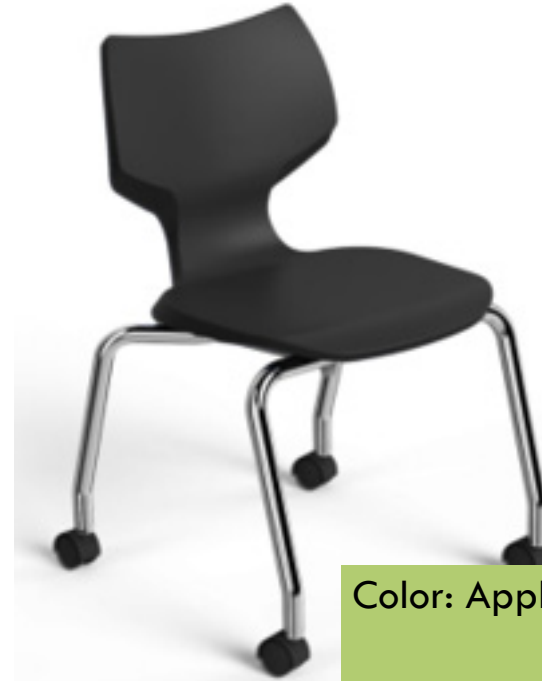

Color: Apple

**CH1:** Smith Systems - Flavors 18"H  
Quantity: 24



Existing Student Desks and Chairs



**CH3:** Smith Systems - Soft Rocker  
Quantity: 3



**M1:** Media Technologies -  
Stowaway Lectern  
Quantity: 1

**SECOND FLOOR: 5TH GRADE CLASSROOMS 42 (ROOMS: 30, 31, 32, 33 & 35 SIMILAR)**

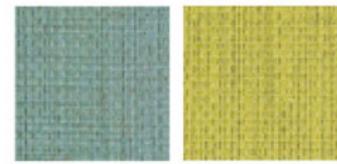

Geyser

Sprout

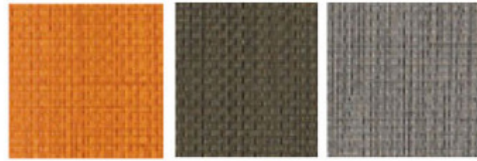

Oriole

Eclipse

Forge



**OPTION 1**

Smith Systems: Soft Rocker

Est. Price: \$500



**OPTION 2**

HON: Skip

Est. Price: \$675 (with seat pad)

Est. Price: \$575 (without seat pad)

**CLASSROOM ROCKER OPTIONS**

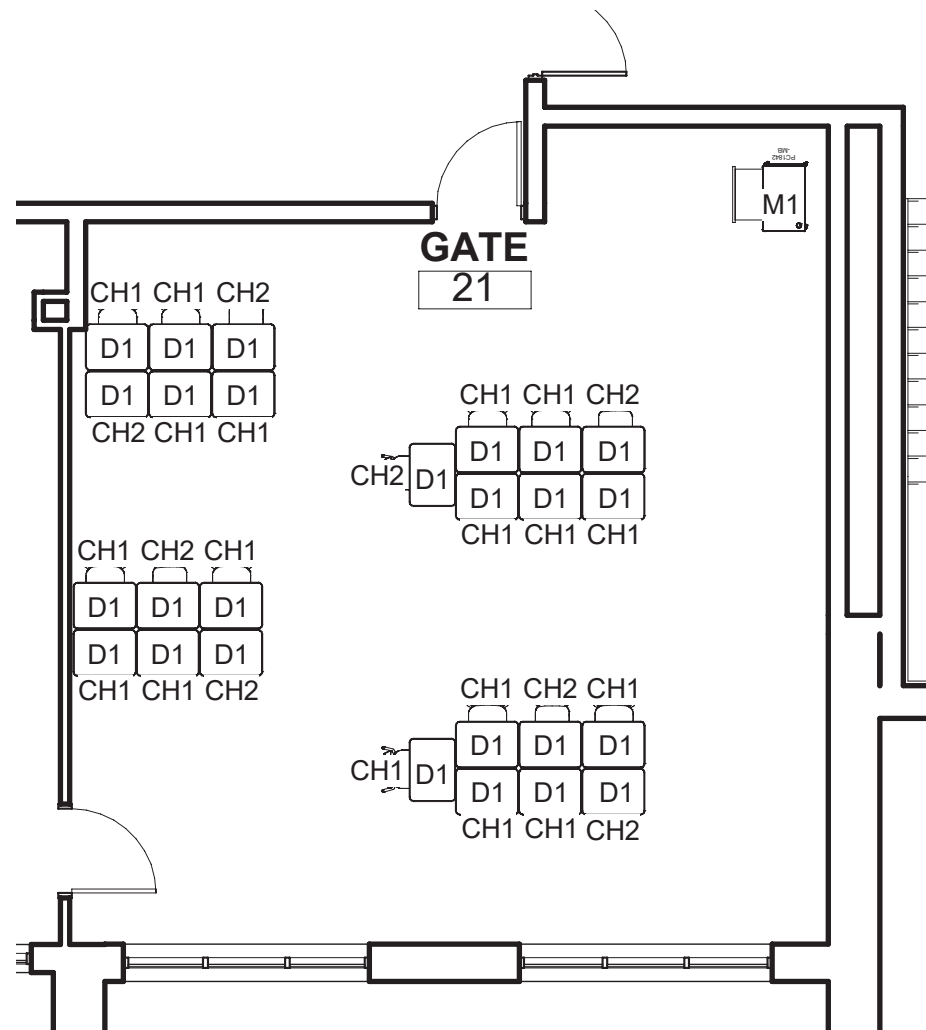

Laminate:  
Classic Linen  
Edge:  
Persian Blue

**D1:** Smith Systems - Silhouette  
Quantity: 26/26



Color: Apple

**CH1:** Smith Systems - Flavors 18"H  
Quantity: 18/17

\*Using both 16" and 18" chairs for 3rd, 4th, and 5th grade use.\*



Existing Student Desks and Chairs

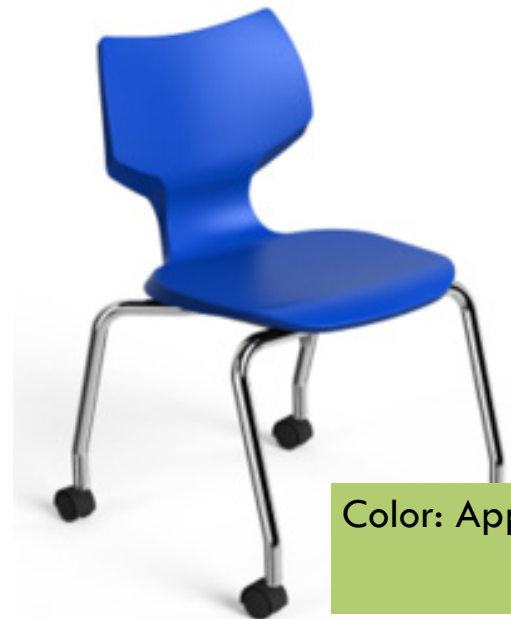

Color: Apple

**CH2:** Smith Systems - Flavors 16"H  
Quantity: 8/9



**M1:** Media Technologies - Stowaway Lectern  
Quantity: 1/1

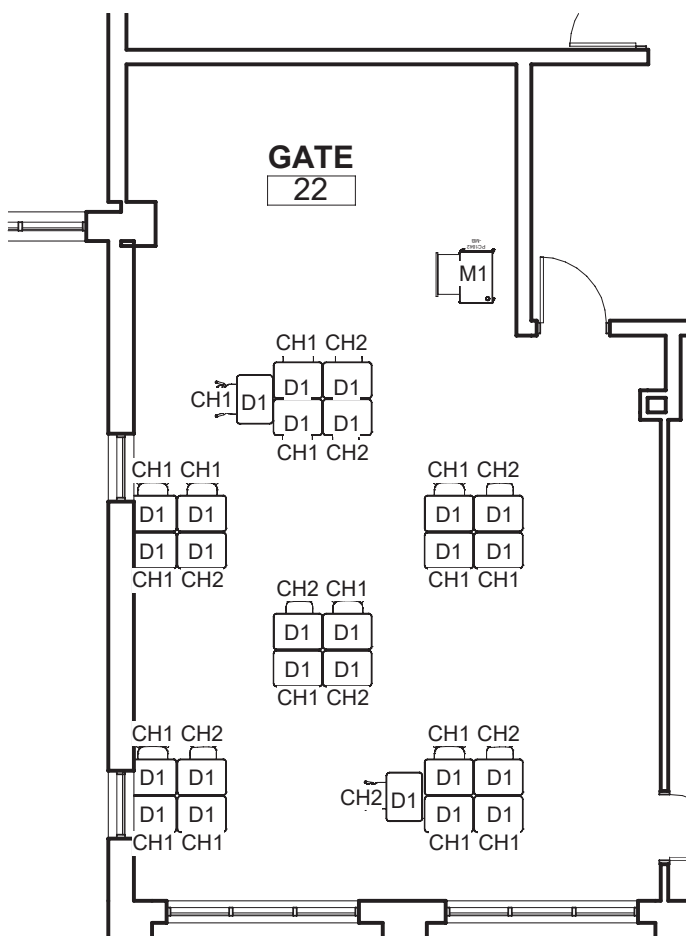

**SECOND FLOOR: GATE 21 (ROOM GATE 22 SIMILAR)**

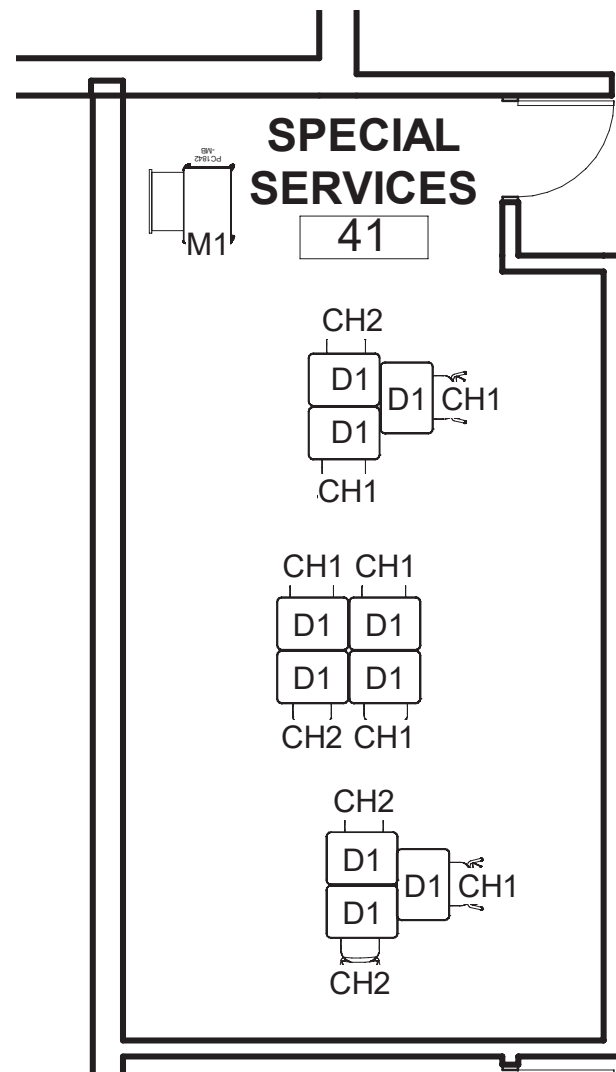

\*Using both 16" and 18" chairs for 3rd, 4th, and 5th grade use.\*



**D1:** Smith Systems - Silhouette  
Quantity: 10



**CH2:** Smith Systems - Flavors 16"H  
Quantity: 4



**CH1:** Smith Systems - Flavors 18"H  
Quantity: 6



**M1:** Media Technologies -  
Stowaway Lectern  
Quantity: 1



Existing Student Desks and Chairs

## SECOND FLOOR: SPECIAL SERVICES 41

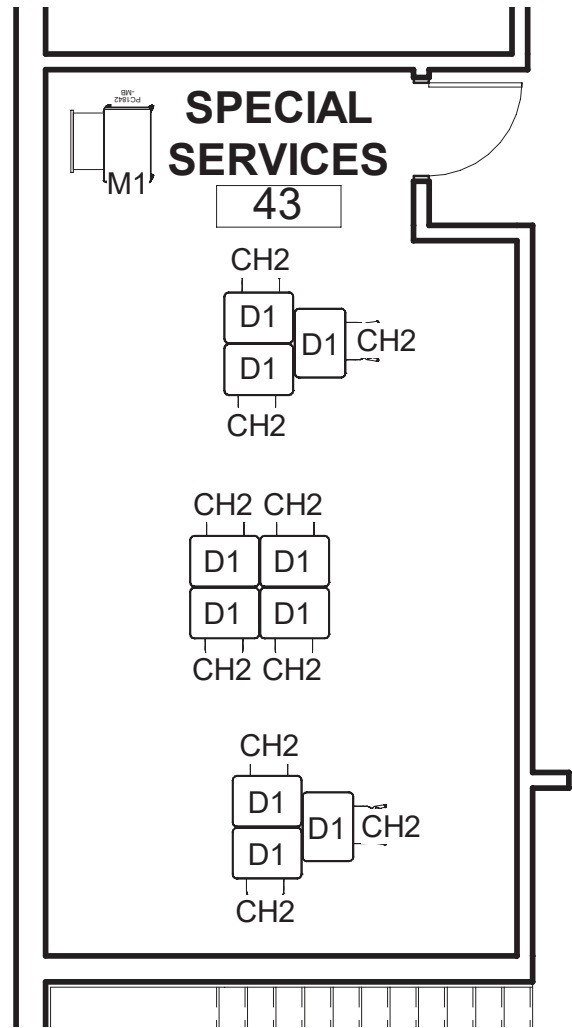

\*Using 16" chairs for 3rd grade use.\*



**D1:** Smith Systems - Silhouette  
Quantity: 10



**CH2:** Smith Systems - Flavors 16"H  
Quantity: 10



**M1:** Media Technologies -  
Stowaway Lectern  
Quantity: 1



Existing Student Desks and Chairs

## SECOND FLOOR: SPECIAL SERVICES 43

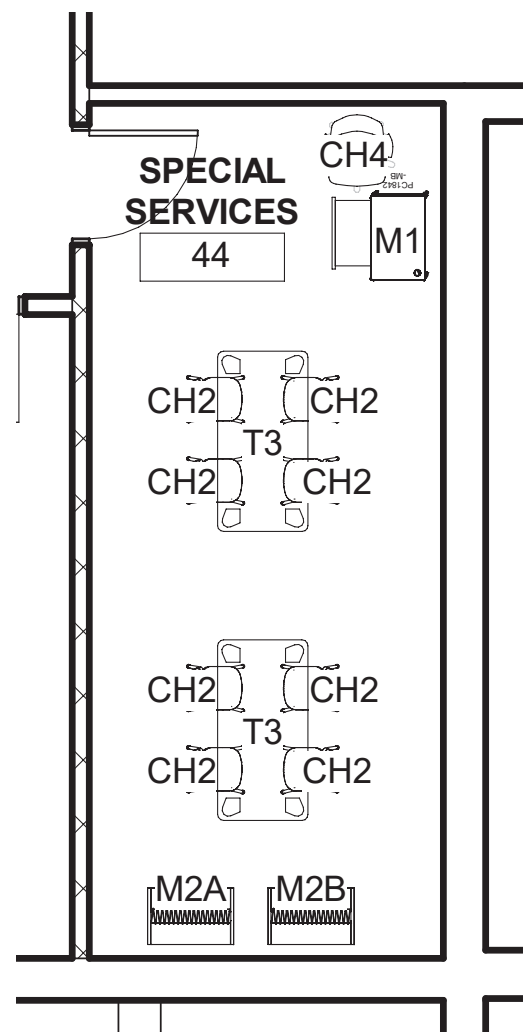

\*Using 16" chairs for 3rd grade use.\*

Sides:  
Persian Blue



**M2A/B:** Smith Systems - Cascade Mega Cabinet w/ Whiteboard & Doors  
Quantity: 2



**T3:** Smith Systems - Elemental Table  
Quantity: 2

Laminate:  
Classic Linen  
Edge:  
Persian Blue



**M1:** Media Technologies - Stowaway Lectern  
Quantity: 1



**CH4:** Allseating - Entail Instock  
Quantity: 1



Color: Apple

**CH2:** Smith Systems - Flavors 16"H  
Quantity: 8



Existing Student Desks and Chairs

SECOND FLOOR: SPECIAL SERVICES 44

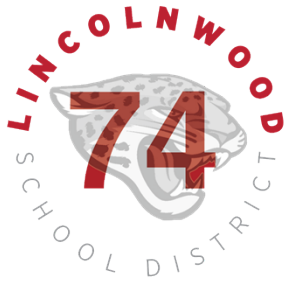

## Executive Summary Facilities Committee Meeting

DATE: March 16, 2021

TOPIC: Ascent© Control Module Upgrade and Data Communication Wiring at Lincoln Hall

PREPARED BY: Jim Caldwell and Courtney Whited

### Recommended for:

- Action
- Discussion
- Information

### Purpose/Background:

A board and two actuators shorted out in room 103 at Lincoln Hall during the February 2021 deep freeze. This created a larger problem within the BAS where other access points were affected. This is when an excessive load was discovered on the BACtalk© Control Module (BCM). Currently, there are two Alerton BCMs at Lincoln Hall. These units are global controllers which are considered the “brains” of the building automation system. They were installed by ABC Building Automation in 2005. They are no longer in production. The recommended load for a BCM is 64 Versatile Logic Controller devices. Control Engineering Corporation reviewed the number of devices currently on each module. Controller one (4000 BCM Network 30) has 47 total devices; 19 of them are third party. Controller two (4100 BCM Network 300) has 80 total devices; 27 of them are third party. Alerton modules should never exceed 64 devices. When adding third party devices it is necessary to reduce the maximum load count. Third party devices are always assumed to be full wave while Alerton devices are half wave. If there was a network consisting solely of third party devices, the maximum limit would be 32, not 64. Control Engineering Corporation provided the attached quote for a solution. District Administration requests the assistance of the architect and engineering firms, Studio GC and IMEG, to verify this is the most appropriate and comprehensive solution.

**Fiscal Impact:**

Unknown

**Recommendation:**

This summary is for informational purposes. The Administration requests direction from the Facilities Committee on next steps relative to the overburdened control module at Lincoln Hall.

3/9/2021

**Lincolnwood School Dist. 74  
Mr. James Caldwell  
6950 N. East Prairie Rd.  
Lincolnwood, IL 60712**

**Lincolnwood SD 74 – Lincoln Hall  
ACM Upg & Improve Wiring Config.  
Proposal**

**CEC Proposal #PWJ21015.1**

Control Engineering Corp. (CEC) is pleased to present this proposal to provide the equipment and technical expertise required to perform the following scope of work for the Lincolnwood School Dist. 74 – Lincoln Hall facility of Lincolnwood, IL.

**Scope of Work – Upg exist. obsolete Alerton BCM to new Alerton ACM & improved comm. wiring**

- CEC will consult with the customer to strategize the most convenient times to perform the following physical system reviews/upgrades/repairs/replacements & will, during the duration of this work, assist in maintaining the normal operations of the facility in an effort to insure that the work is as seamless as possible to the facility’s occupants.
- CEC will provide and install new data communication wiring between Rm. 205 & the current location of the main BAS control panel. This new comm. trunk will be used to split the existing comm. trunk into two separate trunks. The new comm. trunk wiring will pick up all of the existing devices in place that go beyond Rm 205 to the end of the line. The existing comm. trunk line wiring will remain in place & pick up all devices between the main control panel & Rm 205. Upon completion, both comm. trunks will occupy the proper quantity of control devices going forward. These locations were selected based on investigative troubleshooting recently performed under separate order/approval due to offline issues.
- CEC will remove the existing obsolete BCM & it’s associated components.
- CEC will provide, install, program, & commission an upgrade retrofit qty of one (1) new Alerton ACM global controller & its associated licensing & qty of two (2) comm. ports.
- CEC post completion will provide review of the system’s upgrades & modifications.

<b>Total Investment</b>	<b>\$ 12,800.00</b>
-------------------------	---------------------

**Clarifications**

- ❖ Price quoted includes the labor, equipment, and materials listed above. In the event it is determined that any other parts, materials, or additional labor is required due to a request for a change in scope, we will quote you a price and require a PO (purchase order) before proceeding.
- ❖ All work to be performed in accordance with local codes and the above stated scope of work.
- ❖ The project scope of work includes a one-year warranty on any and all parts and/or labor provided upon project completion and beneficial use of the project scope.
- ❖ All work to be completed during normal business hours.
- ❖ The above price is valid for 30 days.

Thank you for the opportunity to assist you with your requirements. Please do not hesitate to contact me should you have any questions, comments, concerns, or require any additional information whatsoever.

Sincerely,



---

*Phillip Jackson*  
*Account Executive*

---

*Accepted by:*

---

*Purchase Order #*

---

*Date*

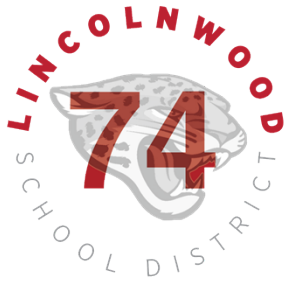

## Executive Summary Facilities Committee Meeting

DATE: March 16, 2021

TOPIC: Lincoln Hall HVAC Hot Water Piping

PREPARED BY: Jim Caldwell and Courtney Whited

### **Recommended for:**

- Action
- Discussion
- Information

### **Purpose/Background:**

Before construction at Lincoln Hall, there were six HVAC pumps; 1 & 2 - dual temp, 3 & 4 - radiation, 5 & 6 - chilled. During construction, new equipment was added to the HVAC system including radiation pumps 7 & 8. Although these additional pumps were added, the piping size remained the same, 5 inches, and no Variable Frequency Drives (VFDs) were installed. Currently, pumps 3, 4, 7 & 8 require the bypass to be open in order to prevent cavitation within the pumps. In early February, United Test and Balance provided recommendations in the attachments.

### **Fiscal Impact:**

Unknown

### **Recommendation:**

This summary is for informational purposes. The Administration requests direction from the Facilities Committee on whether or not to proceed with an assessment performed by the District's architect and engineering firms, StudioGC and IMEG.

# United Building & Energy Services

2100 Manchester Road, St. 601

Wheaton, IL 60187

(630) 790-4940

[utandb@comcast.net](mailto:utandb@comcast.net)

[www.unibesllc.com](http://www.unibesllc.com)

---

## Lincolnwood Middle School Piping

United's initial findings were as follows:

\*Pump 1 & 2 were both running to maintain differential setpoint

\*Pump 4 was running and pump 3 was off

\*Pumps 7 & 8 were running to maintain differential pressure setpoint

Pump 1 & 2 were not evaluated for flow during the assessment as they were not on the piping loop causing issues.

Pump 4 would flow 358-412 GPM depending on the operation of Pumps 7 & 8. During design conditions and the bypass shut, pump 4 would run 362 GPM with heavy cavitation. (The triple duty valve set to 52 with a manufacture min. of 50)

Pumps 7 & 8 had a range of 42-65 GPM with both pumps running (should be 200 GPM). This is due to a restriction in the piping feeding pumps 3, 4, 7 & 8. In order to get design flow pumps 3 and 4 needed to be powered off. While those pumps were off, one pump ran 94 GPM while both pumps ran 98-101 GPM showing that the piping size only allows 100 GPM total flow that should be provided by one pump.

At the end of United's assessment, the bypass for pumps 3, 4, 7, & 8 was opened until there was no cavitation. This prevents the installed controls from working but it also stops the extreme damage associated with cavitation.

### **Final Recommendations:**

\*Controls must be updated to have each set of pumps run as lead lag only. This means that you may run either pump 1 or 2, 3 or 4, 7 or 8 anytime but never both pumps together

*(The reasoning for this is that the piping on all associated pumps is sized for one pump operation and not for any set of pumps to run at the same time.)*

\*Pumps 3 and 4 must have VFDs installed and set up for total flow and then allowed to run on differential pressure following setup.

*(As describe above, you have piping sized for individual pumps only. The flow requirements for pumps 1 or 2, 3 or 4, and 7 or 8 are 595, 340, and 100 GPM respectively. The supply from the heat exchanger is 6 inches meaning that at 8 ft/sec. the pipe would flow 720 GPM and at 12 ft/sec the pipe is capable of flowing 1080 GPM. The ideal range of flow is 4 to 8 ft/sec and while 12 ft/sec is*

*not ideal, it is at the end of the range of acceptable. If all sets of pumps are to run only one pump then the total flow would be 1035 GPM. Adding VFDs to pump 3 and 4 allows those pumps to only use the water required alleviating additional flow from 6-inch pipe that is already performing above the ideal range.)*

Piping for pumps 1 and 2 need to have the bypass removed and reinstalled as a 6-inch pipe for proper flow during a bypass situation.

Piping for pumps 3, 4, 7, and 8 must be redone. Currently it goes from 5-inch piping down to 3-inch creating a massive restriction causing cavitation during normal operation. All piping from the return, supply, and discharge of the 3-way valve must be changed to 5-inch including the 3-way valve as well. Additionally, the 3-inch bypass needs to be changed from 3-inch piping to 5-inch piping for times when the bypass needs to be utilized.

Piping takeoff for pumps 7 & 8 does not need to be changed but during changes to other pumps and piping they simply need to be maintained at 3-inch when they are hooked up again.

All pumps need to have bridge gauges installed across the strainer and pump to be able to properly maintain the pumps. (3 ports: one at the strainer inlet, one at the pump inlet, and one at the discharge of the pump)

United recommends putting in an actuator on each boiler so that each boiler can be isolated from the system when only one boiler is running. As the system stands, when one boiler is running with a setpoint of 180° F, the other boiler allows water flow thus bypassing the first boiler and then mixing the cold bypassed water with the 180° F discharge from the first boiler. This mixing immediately cools down the water so the first boiler is not delivering the design setpoint boiler water temperature.

Lastly, the temperatures from the boiler should be at 190° F anytime it is below 35° F outside. The building heat exchangers should be set to 180° F below 30° F. This will prevent the need for the boilers to ever catch up to the rest of the system during a heating call and will always be 10 degrees higher than the heat exchanger setpoint of 180° F. The loops for the individual systems can be adjusted lower but absolutely should not be lower than 160° F during freezing conditions.

*(When United started at Lincoln Hall, the heat exchanger was set to 143° F and the loops less than that in the 130° F range. What this does is prevent large amounts of the building from ever satisfying a call for heat. When they can't satisfy, the second set of pumps turn on to help the first set of pumps thereby causing increased cavitation. Now there are multiple extra pumps on that can't move the required flow through piping that isn't sized correctly and even if it was sized correctly would never satisfy because the heat needed to do so is not being delivered from the boiler or heat exchanger.)*

\*\*\*All recommended pipe sizing gives may be increased from sizing gives but it cannot be decreased without risking additional cavitation and erosion of piping.

An engineer should review all associated piping to see if further changes are warranted.

\*\*\*Attached is a drawing using the current controls diagram to simplify what work needs to be done

# Lincoln Hall Heating/Cooling Plant

Yellow Lines:  
\*Need to be repiped to be 5 inch pipe

Dotted Yellow Line:  
\*It is a bypass that needs to be changed to 5 inch piping

Green Line:  
\*It is a takeoff for both bypasses and needs to be changed to a 6 inch line

Dotted Green Line:  
\*It is currently 3 inches and needs to be changed to 6 inch

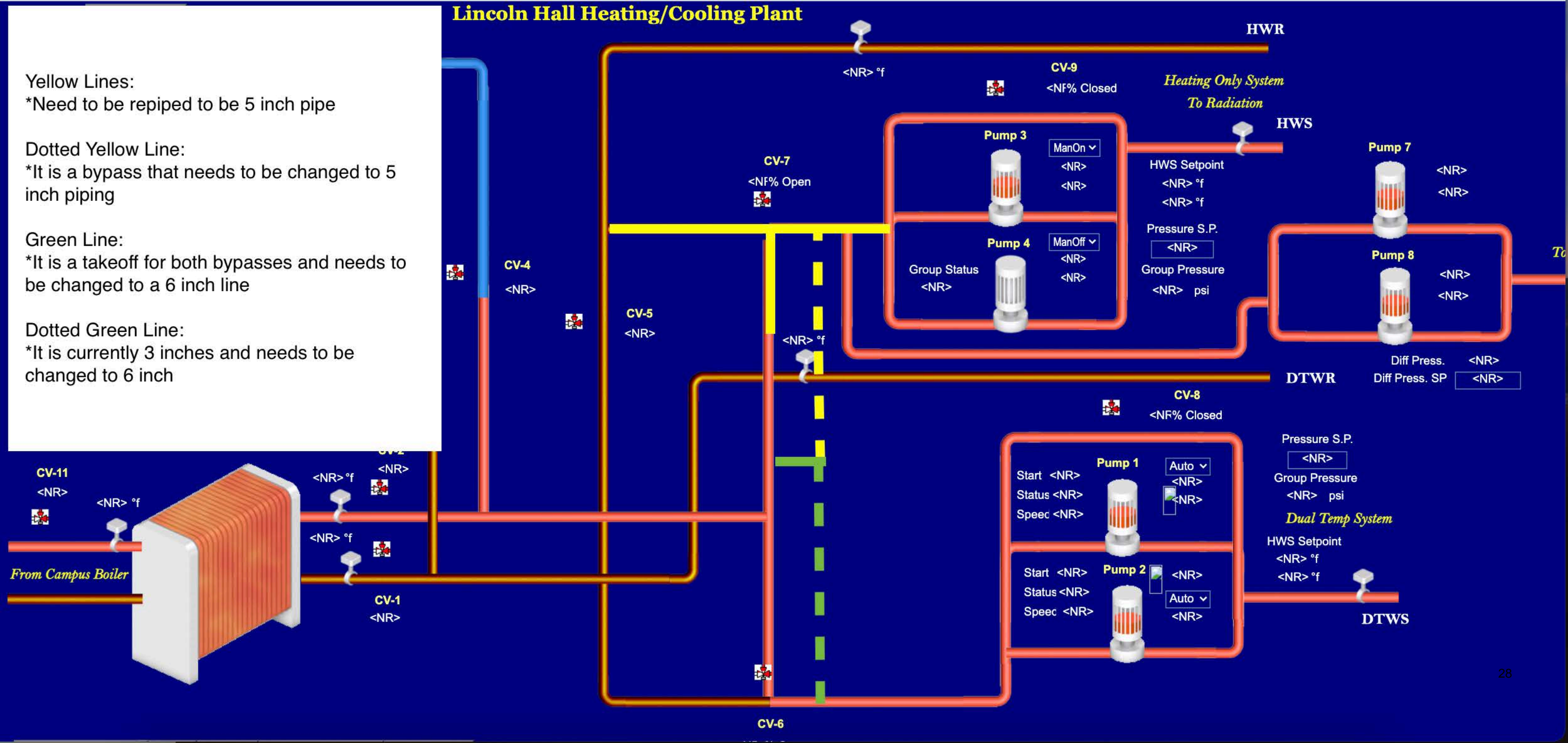

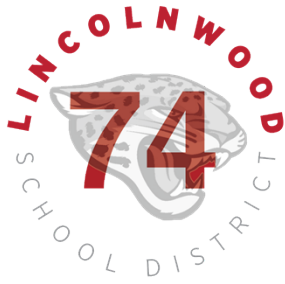

## Executive Summary Facilities Committee Meeting

DATE: March 16, 2021

TOPIC: Drinking Fountains/Bottle Fillers

PREPARED BY: Courtney Whited

### **Recommended for:**

- Action
- Discussion
- Information

### **Purpose/Background:**

There is a defunct drinking fountain in the CCDC wing of Todd Hall. For years, it has been covered by corkboard with posters on top. The Director of CCDC would appreciate a bottle filler drinking fountain in its place. There are other defunct drinking fountains in the elementary schools, as well as older functional fountains without the bottle filler option which have been locked during the pandemic. Locations and the conditions of all elementary drinking fountain/water bottle fillers are attached. Lincoln Hall has the following bottle filler fountains; 4 on the first floor, 7 on the second floor and 4 on the third floor. One additional drinking fountain by the Art Room on the first floor is the only one without a bottle filler. Since students will not occupy Todd Hall or Rutledge Hall this coming summer, an opportunity for any potential drinking fountain work is available.

### **Fiscal Impact:**

Unknown

### **Recommendation:**

This summary is for informational purposes. The Administration requests direction from the Facilities Committee relative to a schedule for any potential future water fountain/bottle filler projects.



**Defunct Drinking Fountain in CCDC wing**



**Defunct Drinking Fountain in CCDC wing photographed from wider angles**

- 6 DRINKING FOUNTAINS**
- 2 DF W/ BOTTLE FILLERS**
- 3 DF CURRENTLY LOCKED**
- 1 DF CURRENTLY OUT OF SERVICE**

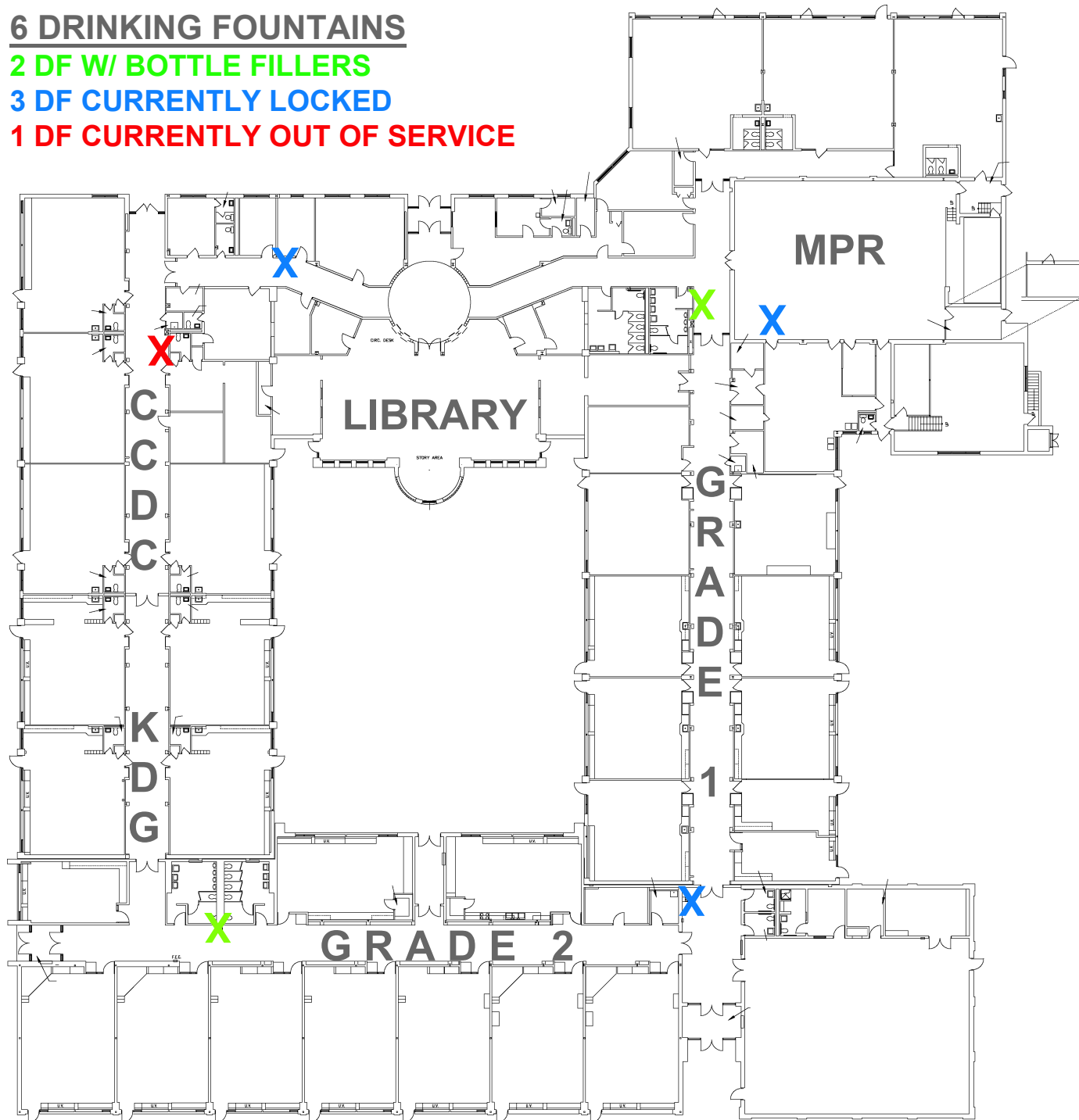

**5 DRINKING FOUNTAINS**

**3 DF W/ BOTTLE FILLER**

**1 DF CURRENTLY LOCKED**

**1 DF OUT OF SERVICE**

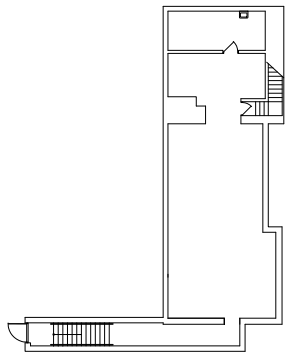
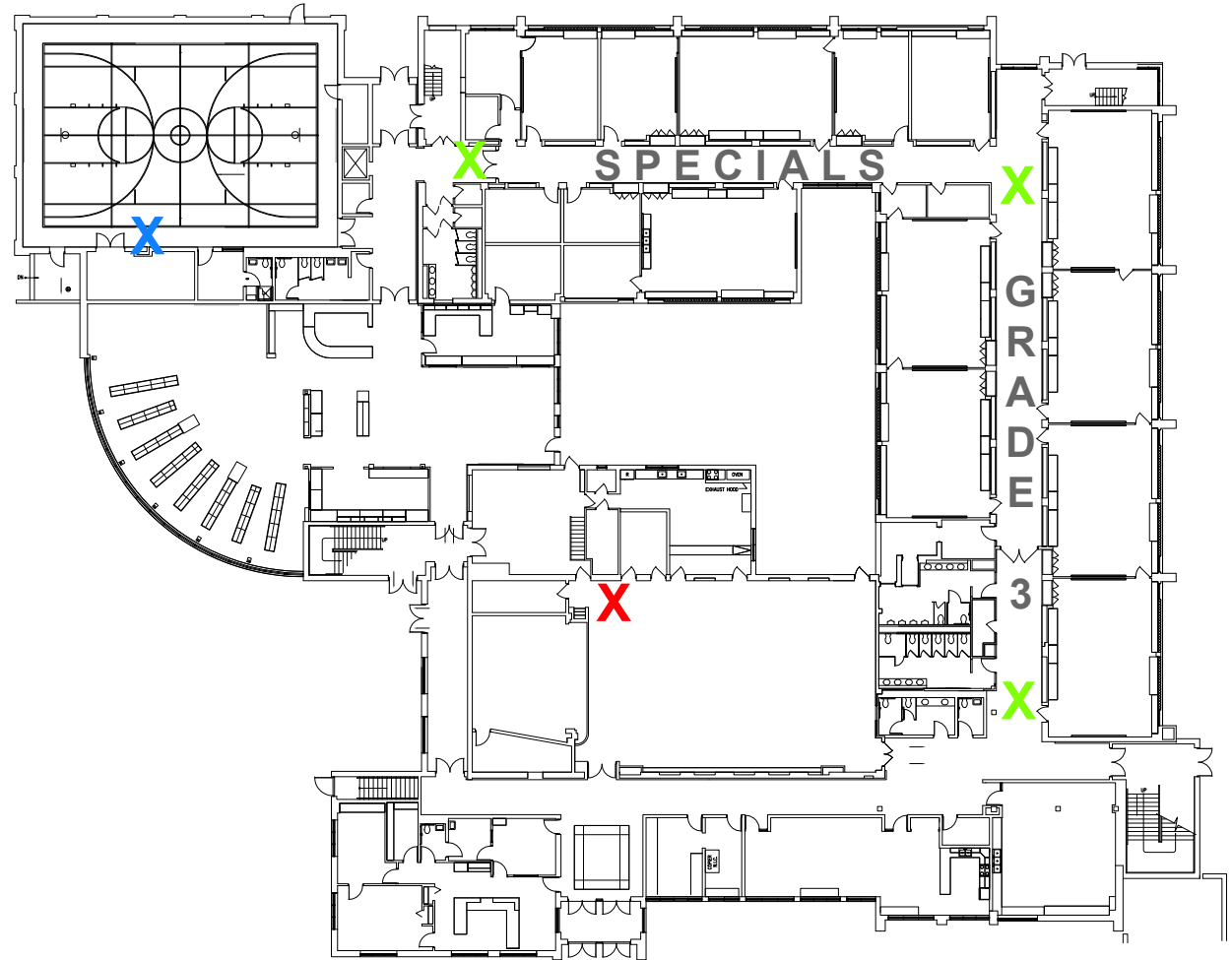

 RUTLEDGE HALL BASEMENT FLOOR PLAN

 RUTLEDGE HALL FIRST FLOOR PLAN

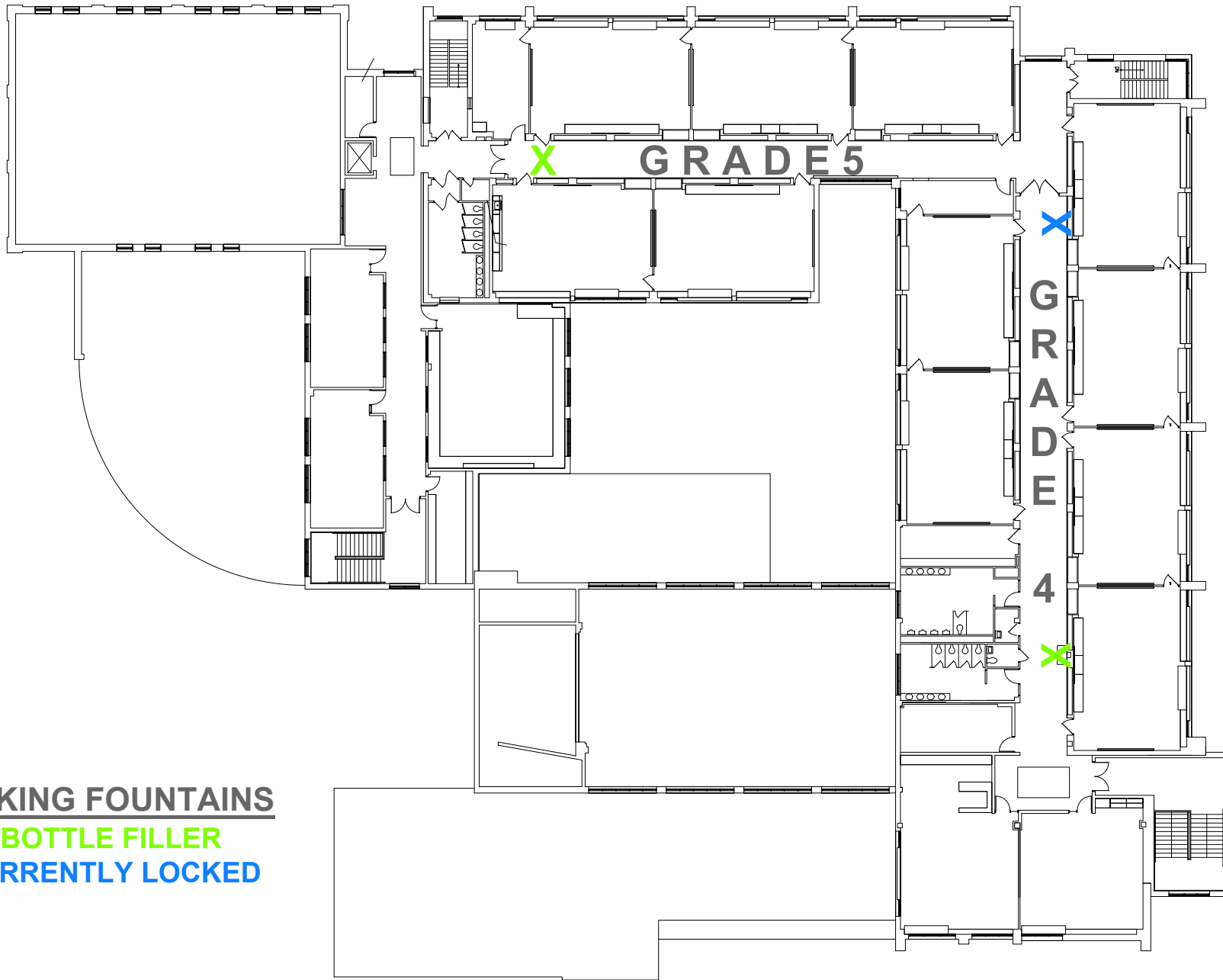

**3 DRINKING FOUNTAINS**  
**2 DF W/ BOTTLE FILLER**  
**1 DF CURRENTLY LOCKED**



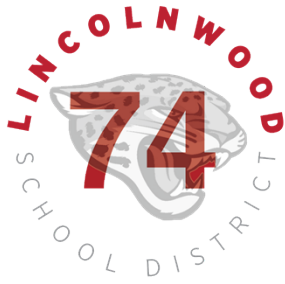

## Facilities Committee Meeting

DATE: March 16, 2021

TOPIC: District Facilities Update

PREPARED BY: Courtney Whited

### Recommended for:

- Action
- Discussion
- Information

### Purpose/Background:

To provide the Facilities Committee an update(s) on ongoing District-wide projects

1. Lincolnwood Baseball Association will begin their April 12 - June 17 rental of the baseball and soccer fields on Mondays - Thursdays from 5:00 PM to 8:00 PM and Sundays from 4:00 PM to 8:00 PM. They are aware Lincoln Hall soccer team games will take place on the southern fields.
2. Water main issue on Farwell Avenue at southeast area of Rutledge Hall.