

**PROSPECT HEIGHTS SCHOOL DISTRICT 23
DISTRICT 23 BUILDINGS & SITES COMMITTEE MEETING**

TUESDAY, MARCH 5, 2024
GRODSKY ADMINISTRATION BUILDING
700 N SCHOENBECK RD
PROSPECT HEIGHTS, IL 60070 at 8:00 AM

Engage ALL students in experiences that inspire EACH to grow as learners, individuals, and community members.

AGENDA

I. Call to Order

II. Discussion Items

A. Update on Glycol Addition for GeoThermal Systems

Rafael will provide an update on the potential need to add glycol to the existing geothermal system and the benefits in doing so.

B. Results of the Window-Siding Replacement Water Test - Anne Sullivan

It was assumed that the moisture intrusion around the Sullivan clerestory windows was due to sealant failure at the window perimeter or there was a sealant failure between the glass and the window frame. The testing report indicates that the cause of the problem is the lack of proper flashing below the windows at the sill. Generally, to correct this problem, the windows will likely need to be removed, masonry repairs made, and the windows reinstalled. This work will be included in the scheduled summer work.

C. Fencing & Concrete Work at Grodsky/Sullivan - Review of Proposals 3

Proposals have been obtained by current District vendors for the replacement of fencing and concrete around the rear Sullivan entrance. Replacement will take place this summer, during the window and siding replacement work.

D. MacArthur Vestibule & Student Senate Furniture Plans

Amy will go over the finalized plans for the Student Senate funded collaboration area at MacArthur.

E. Eisenhower & Prospect Heights Public Library - Book Path Installation 6

The District continues to work with the Prospect Heights Public Library to extend the existing path from the back of Eisenhower School all the way to the Library and add a "book path". This project will be fully funded by the Library.

F. MacArthur Door Repair Update

Rafael will provide an update on the replacement of the MacArthur cafeteria door.

G. Plan for Sealcoating & Striping - Main Campus & Eisenhower 9

On an annual basis, Administration reviews the conditions of the parking lots and interior roads. In doing so, we walked with ARCON Associates to evaluate all conditions and include specific areas into our upcoming bid for striping and seal coating services.

H. Preliminary Garden Planning Discussion

Amy will provide an update on the plan to abate the existing garden at Betsy Ross and develop a new shared Betsy Ross and Anne Sullivan Community Garden area at the rear of the building.

I. Remaining FY24 Furniture Orders

As we begin to wrap up the purchasing for FY24, we will be placing several orders for delivery prior to June 30th. These furniture orders are being placed from budgeted supply line items and have been held towards the end of the year, pending revenue availability. Copies of the proposals and renderings will be shared at the Committee meeting.

III. Adjournment

**PROSPECT HEIGHTS SCHOOL DISTRICT 23
DISTRICT 23 BUILDINGS & SITES COMMITTEE MEETING
TUESDAY, MARCH 5, 2024
GRODSKY ADMINISTRATION BUILDING
700 N SCHOENBECK RD
PROSPECT HEIGHTS, IL 60070 at 8:00 AM**

Engage ALL students in experiences that inspire EACH to grow as learners, individuals, and community members.

AGENDA

DISTRICT ORGANIZATIONAL GOALS

- **Student Success:** Ensure ALL students are well rounded and emotionally and academically prepared for success in high school.
- **Teaching, Learning, and Innovation:** Encourage a learning environment that emphasizes excellence and retains high quality staff.
- **Family and Community Partnership:** Actively engage and communicate with all families to foster collaborative relationships that benefit student learning and understanding of district priorities.
- **Facilities & Financial Planning:** Advance effective use of resources to support safe, learner ready facilities and to maximize student learning.



January 9th, 2024

School District 23

Anne Sullivan Elementary School

700 N Schoenbeck Rd

Prospect Heights, IL 60070

Scope of Work: **\$25,652.00**

PPM will provide all labor, materials, and machinery to remove and replace concrete section per provided map. Proposed section of concrete will be excavated, hauled off site, and disposed of legally. PPM will install 5" of stone base and compact as required. PPM will frame and pour 5" of 4000 psi PCC concrete. Control joints will be provided as required. Light broom finish will be installed. Area will be roped off and secured from foot traffic until fully cured.

PPM will excavate earth and pour new concrete per provided map. Proposed section of earth will be excavated to a depth of 10", hauled off site, and disposed of legally. PPM will install 5" of stone base and roll to required compaction. PPM will frame and pour 5" of 4000 psi PCC concrete. Control joints will be provided as required. Light broom finish will be installed. Area will be roped off and secured from foot traffic until fully cured.

A required allowance of \$3,500.00 for fence removal is not included in this price.

All work to be performed Monday – Friday.

Any work not detailed above will incur an additional charge.

Accepted By: _____



Durabilt Fence
 433 Denniston Court
 Wheeling, IL 60090
 P 847-520-5880 F 847-520-4885
 durabiltfence@gmail.com
 www.durabiltfence.com

Proposal

Expiration Date: 10/17/2023
 Quote Date: 10/10/2023

QU02023-01428 | Prospect Heights School District 23

Billing Address	Prospect Heights School District 23 700 N Schoenbeck Rd Propect Heights , IL 60070 ACC2022-03791	Shipping / Location	700 N Schoenbeck Rd Propect Heights , IL 60070
Point of Contact	Amy McPartlin Phone: (847) 870-5552 Email: amcpartlin@d23.org	Sales Person	Dave Majury (847) 372-4421 durabilt-dave@gmail.com

Description

*New Fence At Ann Sullivan School
 Fence To Be Removed By Others
 Furnish & Install 8' & 10' Chain Link Fence & Gates With PDS
 4" SS40 Gate Post Galvanized
 3" SS40 Terminal Post Galvanized
 2-1/2" SS40 Line Post
 2 x 9 x 8 & 10 Chain Link Galvanized
 1-5/8" SS40 Top - Mid - Bottom - Rail
 PDS Color To Be Picked Later
 2) 10' x 10' Double Drive Gates
 12" Wide Cored Holes
 Re-Use Existing 8' Tall Gate Store On Site*

*Furnish and install 6' Chain Link Fence Around the Stairwell
 Post On Plats Anchored To Concrete
 1) 3' x 6' Walk Gate*

*All Post Set In Concrete
 Prevailing Wages Included*

Inclusions

- * Quality Materials & Professional Workmanship Provided!
- * Removal & Haul Away of Old Materials!
- * Dirt Pick Up & Haul Away Included! (If Required)
- * All Posts Set in Concrete!
- * Public Utility Locates Included!

Exclusions

- Permitting
- Private Utility Locates (Add \$450.00 If Required)

Summary	
Total	14,975.00

Signature _____

Print Name & Title _____

Date _____

Terms & Conditions

- * We Propose hereby to furnish material and labor - complete in accordance with the above specifications, for the sum of: (\$14,975.00) Fourteen Thousand Nine Hundred And Seventy Five Dollars
- * Payment to be made as follows: 50% Down (\$) & Balance Due Upon Completion



Durabilt Fence
433 Denniston Court
Wheeling, IL 60090
P 847-520-5880 F 847-520-4885
durabiltfence@gmail.com
www.durabiltfence.com

Proposal

Expiration Date: 10/17/2023
Quote Date: 10/10/2023

* Note: There is a 3.5% Additional Charge for All Credit Card Transactions (\$

* ALL PERMITS MUST BE OBTAINED BY OWNER

* All material is guaranteed to be as specified. All work to be completed in a workmanlike manner, on a regular time basis according to standard practices. Any alteration or deviation from above specifications involving extra costs will be executed only upon written orders, and will become an extra charge over and above estimate. All agreements contingent upon strikes, accidents or delays beyond our control. Owner to carry fire, tornado and other necessary insurance. Our workers are fully covered by workman's compensation insurance.

* Customer hereby assumes full responsibility for the location of the line upon which said materials are to be installed and locate any and all private cables to include sprinkler systems, electric, septic fields, gas lines, grills, lighting, etc. Durabilt Fence to call J.U.L.I.E.

* Note: This Proposal may be withdrawn by us if not accepted within 7 days.

* I, THE UNDERSIGNED, HEREBY AGREE THAT IN THE EVENT OF DEFAULT IN THE PAYMENT OF ANY AMOUNT DUE, AND IF THIS ACCOUNT IS PLACED IN THE HANDS OF AN AGENCY OR ATTORNEY FOR COLLECTION OR LEGAL ACTION, TO PAY AN ADDITIONAL CHARGE EQUAL TO THE COST OF COLLECTIONS INCLUDING AGENCY AND ATTORNEY FEES AND COURT COSTS INCURRED AND PERMITTED BY LAWS GOVERNING THESE TRANSACTIONS. ALL PAST DUE ACCOUNTS WILL BE CHARGED AT THE RATE OF 1.5% ON UNPAID MONTHLY BALANCE



January 9th, 2024

School District 23

Eisenhower Elementary School

1 North Schoenbeck Road,

Prospect Heights, IL 60070

Scope of Work: _____ **\$25,000.00**

PPM will provide all labor, materials, and machinery to install new path section per provided map. Proposed path earth will be excavated, hauled off site and disposed of legally. PPM will install 8" of stone base and compact as required. PPM will install 2" of IDOT binder course asphalt and roll to required compaction. PPM will install 2" of IDOT surface course asphalt and roll to required compaction.

A required allowance of \$5,000.00 for landscaping restoration is not included in this price.

All work to be performed Monday - Friday.

Any work not detailed above will incur an additional charge.

Accepted By: _____



Barking Dog Interpretive Design
 S12824 County Road U
 Strum, WI 54770
 United States of America
 storywalk@bdexhibits.com

QUOTE # SW23990717

Quote expires 2024-03-19

Amy McPartlin
 Prospect Heights School District 23
 1 N Schoenbeck Rd
 Prospect Heights, Illinois
 60070
 amcpartlin@d23.org

Ship to:
 1 N Schoenbeck Rd
 Prospect Heights, Illinois
 60070

Quote Date: **2024-02-18**
 Payment Method: **Quote**
 Shipping Estimate #: 24-087232

PRODUCT	UNIT	QTY	PRICE
Angled Aluminum Post Mount (SWPWP182445B)	\$302.82	18	\$5,450.76
		Subtotal	\$5,450.76
		Volume Discount	\$-545.08
		Shipping	\$440.00
		Total	\$5,345.68

TEMPORARY PAGE DISPLAY SUGGESTION: Use 10 mil hot laminate to encase the book page/printed page, include an 1/8" edge of clear laminate on all 4 sides of the page. Place page and colored backer between the 2 sheets of acrylic, install into the frame. During seasons with high humidity or rain, condensation or moisture may occur inside the frame. Synthetic paper and permanent panels will offer greater durability than laminated pages.

 Signature

 Date



StoryWalk® Solutions

ALUMINUM FRAME AND ALUMINUM POST - ANGLED

For a 18”h x 24”w page, with a viewable area of 17” h x 23” w.

45 degree display angle.

Standard post length is 60”, for in ground installation

Longer posts and surface mounted posts are available.

Installed height 28”to 32”

Prepare footing depth per your region’s requirements.

Ensure post is plumb and level while back filling with appropriate material.

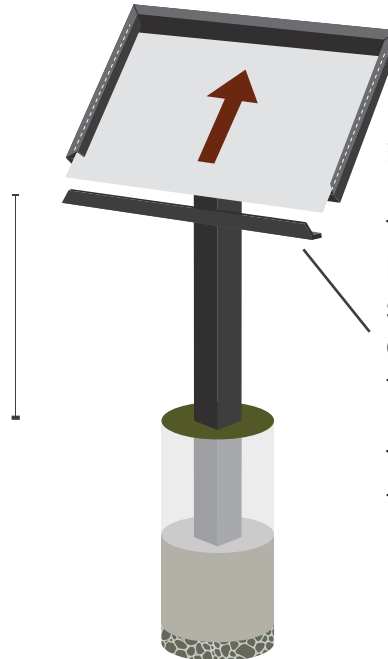

Removable bottom rail for page insertion.

The 2 sheets of acrylic - with the laminated page between them - slide up into the exposed channel on the bottom of the frame.

The powder coated aluminum frame has a 1 year warranty.

Made in the USA!

Assembly Instructions

1. Install the frame to the post plate with the (4) allen head screws, one flat washer, and one nylock nut. The allen driver is provided, you will need a 7/16” socket to install the nylock nut. Do not use power tools as stainless steel hardware will gall and seize.

2. Remove the bottom frame rail 2 screws with the allen driver. Replace the 2 screws using the allen driver.

Page Installation – first time

1. Remove the blue masking from both sides of the acrylic.
2. Place your page and optional colored backer between the sheets of acrylic. Be sure your pages are numbered, or you know what page order they should be installed.
3. Remove the bottom frame rail using the provided driver.
4. Slide the sheets up into the exposed frame channel.
5. Replace the bottom rail.

Cleaning Instructions

Use a soft cloth and dilute soap and water to wash and dry the displays.

DO NOT USE ammonia cleaners (Windex) or paper towels.

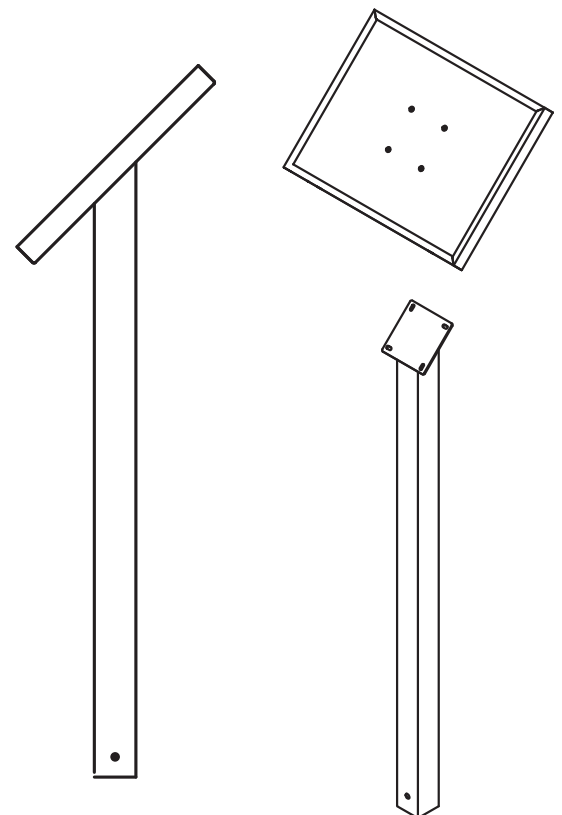

Anne Sullivan
Elementary School

MacArthur
Middle School

Betsy Ross
Elementary School

Patriots Park

Yellow = Asphalt, consider patching
Red, Yellow = Asphalt, needing patching
Orange = Concrete, consider Replacement
Red, Orange = Concrete, needing replacement