

Consent Agenda - Regular School Board Meeting

Duluth Public Schools, ISD 709

Agenda

Tuesday, May 19, 2026

District Services Center

709 Portia Johnson Dr.

Duluth, MN 55811

6:30 PM

1. Consent Agenda

A. Approval of Minutes from Past School Board Meetings

- 1) Regular School Board Meeting — April 21, 2026 3

B. Approval of Action Items

1) Human Resources

- a. HR Staffing Report 6

2) Finance

- a. Financial Report 7

- b. Fundraisers 8

- c. Bids, RFPs and Quotes - None

- d. Contracts, Change Orders, Leases 9

(1) Change Order — Lakewood Elementary Boiler

Replacement (A.G. O'Brien Plumbing and Heating Co.)

(2) Contract — Duluth Public Schools 2025 LTFM Phase 1 15

Projects (Amendment)

3) Items Brought Forward From the Monthly Committee of the Whole Meeting

- a. Social Studies Curriculum Review & Adoption 18

4) Other

- a. Diploma Requests 26

- b. Field Trip Requests

(1) East High School Year Book Camp 46

- c. Data Sharing Agreements

C. Approval of Policy Readings

1) First Readings - None

2) Second Readings - None

3) Policies for Review

- a. 306 Administrator Code of Ethics 49

- b. 413 Harassment and Violence 53

- c. 511 Fundraising 71

- d. 606 Textbooks and Instructional Materials 75

- e. 701 Establishment and Adoption of School District Budget 81

- f. 701.1 Modification of School District Budget 85

D. Approval of Committee Reports

By approving Committee Reports, the board acknowledges and approves all

informational and action items represented in the Regular School Board Meeting Report of each committee.

- | | |
|--|------------|
| 1) <u>Monthly Committee of the Whole</u> - May 5, 2026 | <u>88</u> |
| 2) <u>Policy Committee</u> - May 12, 2026 | <u>153</u> |
| 3) <u>Human Resources/Business Services Committee</u> - May 11, 2026 | <u>178</u> |

Regular School Board Meeting
Tuesday, April 21, 2026 6:30 PM Central

District Services Center
709 Portia Johnson Dr.
Duluth, MN 55811

Henry Banks: Present
Kelly Durick Eder: Present
Rosie Loeffler-Kemp: Present
Jill Lofald: Present
Sarah Mikesell: Present
Amber Sadowski: Present
Stephanie Williams: Present

Present: 7.

Member Williams left at 7:04 p.m. and returned at 7:08 p.m.

1. Call to Order
at 6:35 p.m.

2. Roll Call

3. Pledge of Allegiance

4. Approval of the Agenda

Move to Approve the Agenda. This motion, made by Rosie Loeffler-Kemp and seconded by Jill Lofald, Passed.

Henry Banks: Yea, Kelly Durick Eder: Yea, Rosie Loeffler-Kemp: Yea, Jill Lofald: Yea, Sarah Mikesell: Yea, Amber Sadowski: Yea, Stephanie Williams: Yea

Yea: 7, Nay: 0

5. School and Community Recognition

Assistant Superintendent Bonds presented the School and Community Recognition.

6. Report of the Superintendent

6.A. Reports from Student School Board Representatives

Student Representative Mattila presented the East Student Report.

6.B. Superintendent's Report

Superintendent Magas presented the Superintendent's Report. Topics included:

Student Representative Reports

Budget Reduction

Legislative Update

Litigation Update

Education Equity Advisory Committee Bylaws

Area Learning Center Update: The Minnesota Department of Education has changed the approval for a four-day school week this year. We need to submit the application. They will allow for significant flexibility as the school board has approved four-day weeks for the Area Learning Center in the Duluth Federation of Teachers Contracts from 2011 up through 2027.

Other

6.C. Schedule of Meetings and Events

7. Report of Standing Committees

7.A. Committee of the Whole

7.A.1) Monthly Committee of the Whole (*April 7, 2026*)

Assistant Superintendent Bonds presented the Committee of the Whole Report.

7.B. Human Resources/Business Services Committee (*April 13, 2026*)

Member Sadowski presented the Human Resources/Business Services Committee Report.

7.C. Policy Committee (*April 9, 2026*)

Member Loeffler-Kemp presented the Policy Committee Report.

8. General Board Committee Updates

Member Sadowski gave an update on the Intergovernmental meeting.

Member Loeffler-Kemp gave an update on the Head Start Parent Policy Council, Parent Advisory Council on Special Education and Safe Routes to Schools meetings.

Member Mikesell gave an update on the Intergovernmental and the District Advisory Committee meetings.

9. Consent Agenda

Move to Approve the Consent Agenda. This motion, made by Stephanie Williams and seconded by Amber Sadowski, Passed.

Henry Banks: Yea, Kelly Durick Eder: Yea, Rosie Loeffler-Kemp: Yea, Jill Lofald: Yea, Sarah Mikesell: Yea, Amber Sadowski: Yea, Stephanie Williams: Yea

Yea: 7, Nay: 0

10. Resolutions from Committee Reports

10.A. B-4-26-4162 - Acceptance of Donations to Duluth Public Schools

Move to Approve Resolution B-4-26-4162 Acceptance of Donations to Duluth Public Schools. This motion, made by Jill Lofald and seconded by Amber Sadowski, Passed.

Henry Banks: Yea, Kelly Durick Eder: Yea, Rosie Loeffler-Kemp: Yea, Jill Lofald: Yea, Sarah Mikesell: Yea, Amber Sadowski: Yea, Stephanie Williams: Yea

Yea: 7, Nay: 0

10.B. B-4-26-4163 - Resolution Establishing School Forest Site For Myers-Wilkins

Elementary School

Move to Approve Resolution B-4-26-4163 Establishing School Forest Site for Myers-Wilkins Elementary School. This motion, made by Amber Sadowski and seconded by Henry Banks, Passed.

Henry Banks: Yea, Kelly Durick Eder: Yea, Rosie Loeffler-Kemp: Yea, Jill Lofald: Yea, Sarah Mikesell: Yea, Amber Sadowski: Yea, Stephanie Williams: Yea

Yea: 7, Nay: 0

Discussion was had.

11. Special Resolutions and Action Items

11.A. B-4-26-4164 - Acceptance of Grant Awards to Duluth Public Schools

Move to Approve Resolution B-4-26-4164 Acceptance of Grant Awards to Duluth Public Schools. This motion, made by Rosie Loeffler-Kemp and seconded by Stephanie Williams, Passed.

Henry Banks: Yea, Kelly Durick Eder: Yea, Rosie Loeffler-Kemp: Yea, Jill Lofald: Yea, Sarah Mikesell: Yea, Amber Sadowski: Yea, Stephanie Williams: Yea

Yea: 7, Nay: 0

Discussion was had.

11.B. Approval of Education Equity Advisory Committee (EEAC) Bylaws

Move to Approve the Education Equity Advisory Committee (EEAC) Bylaws. This motion, made by Kelly Durick Eder and seconded by Rosie Loeffler-Kemp, Passed.

Henry Banks: Yea, Kelly Durick Eder: Yea, Rosie Loeffler-Kemp: Yea, Jill Lofald: Yea, Sarah Mikesell: Yea, Amber Sadowski: Yea, Stephanie Williams: Yea

Yea: 7, Nay: 0

Discussion was had.

12. Questions / Other

Member Sadowski recognized Member Lofald as the Section 7AA Coach of the Year.

13. Adjournment

Move to Adjourn at 8:25 p.m. This motion, made by Amber Sadowski and seconded by Stephanie Williams, Passed.

Henry Banks: Yea, Kelly Durick Eder: Yea, Rosie Loeffler-Kemp: Yea, Jill Lofald: Yea, Sarah Mikesell: Yea, Amber Sadowski: Yea, Stephanie Williams: Yea

Yea: 7, Nay: 0

Chair Durick Eder

Clerk Mikesell

HUMAN RESOURCES ACTION ITEMS FOR: MAY 19, 2026

<u>CERTIFIED APPOINTMENT</u>	<u>POSITION</u>	<u>EFFECTIVE DATES</u>
ANDERSON, LUCAS K	LTS ELEMENTARY ART/CONGDON, (BA) III, 8, 0.8 CONGDON, 0.2 MERRITT CREEK ACADEMY GRANKE S.	04/23/2026
MITCHELL, NATHAN P	LTS VOCAL MUSIC TEACER/ORDEAN EAST, (MA) IV, 9, 0.4, STARR E.	04/13/2026
PRIESTLEY, TAYLOR S	LTS, ENGLISH TEACHER/EAST, (BA) III, 1, 1.0, ZOBEL J.	04/24/2026
REDIG, KAEDYN D	LTS SEB SPECIALIST/MYERS-WILKINS, (BA+45) III, 1, 1.0, SMITH M.	04/06/2026
<u>CERTIFIED RESIGNATION</u>	<u>POSITION</u>	<u>EFFECTIVE DATES</u>
BACHINSKI, SUSAN D	LTS PRE K - LAURA MACARTHUR ES	04/17/2026
GORDON, MADISON M	SPED SETTING III/IV - LINCOLN PARK MS	07/31/2026
KARG, GRETCHEN A	LITERACY LEAD TOSA - DW	06/05/2026
<u>NON-CERT APPOINTMENT</u>	<u>POSITION</u>	<u>EFFECTIVE DATES</u>
BAKER, AMANDA M	PRESCHOOL 2ND PARA/STOWE, 23/38WKS, \$20.80/HR, WITUCKI-VETSCH A.	04/13/2026
BROOKS, JASMINE M	HOULRY MONITOR/MYERS-WILKINS, UP TO 23HRS/38WKS, \$15.00/HR	04/13/2026
KOSKI, MATTHEW L	SPED BUILDING WIDE PARA/MYERS-WILKINS, 31.25/38WKS, \$20.80/HR, GOERDT J.	04/20/2026
LINDBERG, JENNIE L	HOURLY MONITOR/HOMECROFT, UP TO 23HRS/38WKS, \$15.00/HR	04/15/2026
MORBERG, HEATHER M	ASSISTANT MANAGER OF FACILITIES AND MAINTENANCE TRADES/DISTRICT WIDE, \$1,569/WKS, DEGRAEF J.	04/13/2026
MUNSON, LAURA A.M.	ATTENDANCE IMPROVMENT CLASSROOM TUTOR PARA/DENFELD, UP TO 20HRS/38WKS, \$19.23/HR	04/23/2026
PETERS, TODD A	HOURLY FOOD SERVICE/DISTRICT WIDE, UP TO 12HRS/38WKS, \$14.00/HR	04/14/2026
SHEVCHUK, ROBERT L, SR	FLOAT CUSTODIAN/DISTRICT WIDE, 40/25WKS, \$19.04/HR	05/04/2026
<u>NON-CERT RESIGNATION</u>	<u>POSITION</u>	<u>EFFECTIVE DATES</u>
GUERNSEY, LACECELIA L	CULTURAL IMMERSION PROG PARA - LOWELL ES	05/08/2026
PLZAK, BENJAMIN P	SPED BW PARA - EAST HS	06/05/2026
<u>NON-CERT RETIREMENT</u>	<u>POSITION</u>	<u>EFFECTIVE DATES</u>
FILLMORE, JOHN B	SPED BW PARA - EAST HS	06/05/2026
FRONDEN, KAREN A	ECFE PARA - LESTER PARK ES	06/04/2026
MCKOWSKI, DEBRA A	CAFETERIA MANAGER - ORDEAN-EAST MS	06/05/2026
PUFF, JODI M	CAFETERIA MANAGER - HOMECROFT ES	05/01/2026
<u>NON-CERT PRESUMED RESIGNED</u>	<u>POSITION</u>	<u>EFFECTIVE DATES</u>
CHRAPKOWSKI, SARAH E	SCHOOL CUSTODIAN 1 - ORDEAN-EAST MS	05/19/2026

Duluth Public Schools

REVISED BUDGET

HR/BS Services Committee Monthly Fund Balance Report May 11, 2026 Committee Meeting

BUDGET SUMMARY

05/08/26

Percent spent

REVENUES	25-26		25-26		25-26		25-26		
	CURRENT YEAR ADOPTED BUDGET		CURRENT YEAR REVISED BUDG		RECEIVED TO YEAR TO DATE		RECEIVED ENCUMBERED		
	FUND	Jul-25	JULY 25-26	July -June	July -June	July -June	BUDGET BALANCE		
General	1	\$ 134,020,612.52	\$ 137,502,407.11	\$ 87,665,778.92	\$ 17,575.41	\$ 49,819,052.78			64%
REVISED REVENUE - SPECIAL EDUCATION			\$ 5,256,647.00						
REVISED REVENUE - + 32 ADM adjustment			\$ 239,392.00	TOTAL REVISED REV = \$5,496,039.00					
Food Service	2	\$ 6,120,000.00	\$ 6,120,000.00	\$ 4,150,487.57	\$ -	\$ 1,969,512.43			68%
Transportation	3	\$ 3,866,200.00	\$ 3,866,200.00	\$ 3,421,241.65	\$ 82.88	\$ 444,875.47			88%
Community Ed	4	\$ 8,187,495.00	\$ 8,187,495.00	\$ 4,760,071.54	\$ -	\$ 3,427,423.46			58%
Operating Capital	5	\$ 4,680,435.48	\$ 1,974,644.89	\$ 1,130,087.02	\$ -	\$ 844,557.87			57%
Building Construction	6	\$ -	\$ -	\$ -	\$ -	\$ -			
Debt Service Fund	7	\$ 27,857,301.00	\$ 27,857,301.00	\$ 2,212,780.97	\$ -	\$ 25,644,520.03			8%
Trust Fund	8	\$ 320,000.00	\$ 320,000.00	\$ -	\$ -	\$ 320,000.00			0%
Dental Insurance Fund	20	\$ 959,836.00	\$ 959,836.00	\$ 994,059.63	\$ -	\$ (34,223.63)			104%
Student Acitivity	79	\$ 106,940.00	\$ 110,490.00	\$ 395,954.68	\$ -	\$ (285,464.68)			358%
REVENUE	TOTALS:	\$ 186,118,820.00	\$ 192,394,413.00	\$ 104,730,461.98	\$ 17,658.29	\$ -	\$ 82,150,253.73		54%

EXPENSES	25-26		25-26		25-26		25-26		
	CURRENT YEAR ADOPTED BUDGET		CURRENT YEAR REVISED BUDG		EXPENSES TO YEAR TO DATE		EXPENSES ENCUMBERED		
	FUND	Jul-25	JULY 25-26	July - June	July -June	July - June	BUDGET BALANCE		
General	1	\$ 128,563,977.06	\$ 141,996,095.72	\$ 109,635,129.36	\$ 2,438,118.14	\$ 29,922,848.22			79%
Food Service	2	\$ 6,095,464.00	\$ 6,095,464.00	\$ 4,529,171.47	\$ 1,136,491.61	\$ 429,800.92			93%
Transportation	3	\$ 7,864,200.00	\$ 7,864,200.00	\$ 8,487,285.49	\$ 294,117.01	\$ (917,202.50)			112%
Community Ed	4	\$ 7,725,252.00	\$ 7,725,194.86	\$ 6,158,288.20	\$ 36,240.97	\$ 1,530,665.69			80%
Operating Captial	5	\$ 5,648,724.89	\$ 5,648,724.89	\$ 6,353,094.96	\$ 1,763,653.39	\$ (2,468,023.46)			144%
Building Construction	6	\$ -	\$ -	\$ 11,465,226.72	\$ 16,995,519.09	\$ (28,460,745.81)			
Debt Service Fund	7	\$ 27,394,520.00	\$ 27,394,520.00	\$ 27,396,084.69	\$ -	\$ (1,564.69)			100%
Trust Fund	8	\$ 270,842.00	\$ 270,842.00	\$ -	\$ -	\$ 270,842.00			0%
Dental Insurance Fund	20	\$ 1,025,548.00	\$ 1,025,548.00	\$ 1,150,781.13	\$ -	\$ (125,233.13)			112%
Student Acitivity	79	\$ 86,750.00	\$ 753,465.85	\$ 279,013.61	\$ 64,993.44	\$ 409,458.80			46%
EXPENSE	TOTALS	\$ 184,675,277.95	\$ 198,774,055.32	\$ 175,454,075.63	\$ 22,729,133.65	\$ -	\$ 590,846.04		100%

** special ed orginial budget R & E	\$26,085,315.00
adjusted w/ cross subsidy R	\$31,341,962.00
adjusted w/cross subsidy E	\$36,480,478.00
adjusted budget per sped	\$38,642,836.68

Extra Curricular Fund 01 Prog 298
Revenue \$ 518,435.40
Expense \$ 639,194.37

**Fundraisers Reported
April 2026**

The following fundraisers were reported in the above timeframe and per Policy 511–Fundraising, require School Board approval:

School	Organization Fundraising	Estimated Profit	Description of Fundraiser
East HS	Schoolwide	\$1,000.00	Flowers for Graduates (Bouquets available for pick up at commencement)
East HS	History Day Showcase	\$400.00	History Day Showcase - GoFundMe



ICS
1331 Tyler Street NE, Suite 101
Minneapolis, Minnesota 55413
Phone: (763) 354-2670
Fax: (763) 780-2866

Project: S25052-LkwdESBoiler - Duluth Public Schools, ISD #709 -
Lakewood Elementary Boiler Replacement
5207 N. Tischer Road
Duluth, Minnesota 55804

Contract Change Order #001: CCO #01 AG Obrien

Table with contract details including CONTRACT COMPANY, CONTRACT FOR, DATE CREATED, CONTRACT STATUS, REQUEST RECEIVED FROM, DESIGNATED REVIEWER, DUE DATE, INVOICED DATE, REFERENCE, PAID IN FULL, ACCOUNTING METHOD, FIELD CHANGE, and TOTAL AMOUNT.

DESCRIPTION:
CE #001 - Include Propane Tank Procurement & Installation
Furnish and install of the propane tank per Work Scope 04 and specification 23 13 00.

ATTACHMENTS:
CE #001 - Include Propane Tank Procurement & Installation.pdf

CHANGE ORDER LINE ITEMS:
CCO #001

Table with 4 columns: #, Cost Code, Description, Type, Amount. Includes a subtotal and grand total row.

The original (Contract Sum) \$ 494,390.00
Net change by previously authorized Change Orders \$ 0.00
The contract sum prior to this Change Order was \$ 494,390.00
The contract sum would be changed by this Change Order in the amount of \$ 234,309.90
The new contract sum including this Change Order will be \$ 728,699.90
The contract time will not be changed by this Change Order by

A.G. O'Brien Plumbing and Heating Co.
4907 Lightning Drive
Duluth Minnesota 55811

ICS - Minneapolis, MN
1331 Tyler Street N.E., Suite 101
Minneapolis Minnesota 55413

Duluth Public Schools ISD #709
709 Portia Johnson Drive
Duluth Minnesota 55811

SIGNATURE DATE SIGNATURE DATE SIGNATURE DATE



ICS
1331 Tyler Street NE, Suite 101
Minneapolis, Minnesota 55413
Phone: (763) 354-2670
Fax: (763) 780-2866

Project: S25052-LkwdESBoiler - Duluth Public Schools, ISD #709 -
Lakewood Elementary Boiler Replacement
5207 N. Tischer Road
Duluth, Minnesota 55804

CE #001 - Include Propane Tank Procurement & Installation

CREATED BY:	Mark Needham	CREATED DATE:	5/8/2026
STATUS:	Under Review	POTENTIAL CHANGE ORDER:	(None)
ASSIGNEE:	Paul Konkler (A.G. O'Brien Plumbing and Heating Co.)		

DISTRIBUTION:

SCOPE DESCRIPTION:

Include Propane Tank Procurement & Installation

REQUEST DETAILS:

CE #001 - Include Propane Tank Procurement & Installation

Furnish and install of the propane tank per Work Scope 04 and specification 23 13 00.

ATTACHMENTS:

RESPONSES

Date	Response By	Quote Amount	Schedule Impact	Comments	Attachments/Details
05/08/2026	Mark Needham	\$234,309.90	0 days	Includes OH&P for AG Obrien Management	

CHANGE ORDER COMPONENTS

CCO: (None)

NEGOTIATED AMOUNT:

Edwards Oil, Inc
 820 Hoover Road North
 Virginia, MN 55792
 Phone: 218-741-9634
 sskalko@eoctrimark.com

Date	Estimate #
5/8/2026	5446

Name / Address
AG O'Brien 4907 Lightning Drive Duluth, MN 55811

Terms
50% DOWN

THIS ESTIMATE IS NULL AND VOID AFTER 7 DAYS FROM DATE OF ESTIMATE. This estimate is for completing the job as described above. It is based on our evaluation and does not include material price increases or additional labor and material which may be required should unforeseen problems or adverse weather conditions arise after the work has started.

PROJECT
Lakewood - LP

Item	Description	Qty	Cost
	Used 18,000 gallon propane tank installed with the following		
	-Precast piers (Includes all dirtwork needed to complete)-		
	Class 1 Div 1 electric vaporizer		
	-Vapor bypass system		
	-Vapor distribution piping the tank/vaporizer to the school-		
	All valves and piping needed to fill the tank via transport		
	Vaporizer, Regulators, and Piping sized to deliver 4.5 million BTU		
PROPANE TANK 18,000	USED 18,000 GALLON PROPANE TANK ((1960's ERA))	1	
FREIGHT	Tank Freight	1	
PIERS#7	109" X 8" - 0" PRE-CAST PIER	2	
MISCELLANEOUS SUPPLIES	EXCAVATION AND DIRT WORK FOR PIERS	1	
MISCELLANEOUS SUPPLIES	ROCK FOR PIER BASE	1	
P-PADS-1	FELT - HIGH DENSITY FOAM PAD	2	
MISCELLANEOUS SUPPLIES	CRANE FEE	1	
MISCELLANEOUS SUPPLIES	4'X4' CONCRETE PAD FOR VAPORIZER	1	
H284-250	2' SEMI-INTERNAL PRESSURE RELIEF	2	
ME830	VALVE-LIQUID LEVEL VENT 34/" MPT X 1/4" FPT	1	
65529	1/4" x 2" XH Nipple	2	
0467129	1/4 FS THD 90 ELBOW	1	
ASG4004	4" NH3 0-400 PSI 4" Dial Bottom Stem	1	
C6342-11-108	MAGNETEL GAUGE FOR 108 ID TK EM HEMI HEAD 2	1	
LP-ME931	1/2" ADAPTER GAUGE MODEL B	1	
MEJ701	6" THERMOMETER 2" DIAL SS 1/2"	1	
C477-24-37	3" FISHER INTERNAL VALVE	1	
C477-16	2" FISHER INTERNAL VALVE	3	
4186535	3" X 2" SWAG NIPPLE XH	1	
4186513	2" X 1 1/4" SWAGE NIPPLE XH	1	
4186511	2" X 1" X-HEAVY SWAGE NIPPLE	2	
A7513AP	2" GLOBE VALVE FPT	1	
AL312P A7509BP	1-1/4 GLOBE VALVE	1	
A7507AP	1" GLOBE VALVE	1	
AL311P	1" ANGLE VALVE	1	

		Sales Tax (8.875%)
	PLUS ANY APPLICABLE SALES TAX	Total
		11

Edwards Oil, Inc
 820 Hoover Road North
 Virginia, MN 55792
 Phone: 218-741-9634
 sskalko@eoctrimark.com

Date	Estimate #
5/8/2026	5446

Name / Address
AG O'Brien 4907 Lightning Drive Duluth, MN 55811

Terms
50% DOWN

THIS ESTIMATE IS NULL AND VOID AFTER 7 DAYS FROM DATE OF ESTIMATE. This estimate is for completing the job as described above. It is based on our evaluation and does not include material price increases or additional labor and material which may be required should unforeseen problems or adverse weather conditions arise after the work has started.

PROJECT
Lakewood - LP

Item	Description	Qty	Cost
AL313P	1-1/4" ANGLE VALVE	1	
A7514AP	2" ANGLE VALVE	1	
ME980C-6	3/4" FPT EMERGENCY SHUT OFF VALVE WITH CABLE	1	
4186479	LATCH 1 x 3/4 Swage Nipple	1	
ME880-6/28	VALVE-EX FLO 28 GPM BRASS MARSHALL EXCELSIOR	1	
TCHS2-200 8MMT-20	2" X 20" SS FLEX CONNECTOR	1	
0467398	2" FS UNION	1	
0467136	2" FS 90 DEGREE ELBOW	2	
0467199	2" FS 45 DEGREE ELBOW	1	
65614	2" X 6" XH NIPPLE	6	
2BSXHPE	2" X 21' SCH 80 BLACK PIPE (PER FOOT)	10	
0467396	1 1/4" FS UNION	1	
0467134	1 1/4" FS 90 DEGREE ELBOW	2	
0467146	1 1/4" FS 45 DEGREE ELBOW	1	
65592	1 1/4" X 6" XH NIPPLE	6	
114BSXHPE	1 1/4" X 21' SCH80 BLACK PIPE (PER FOOT)	10	
0467395	1" FS UNION	1	
65579	1" X 5" XH NIPPLE	2	
0467133	1" FS 90 DEGREE ELBOW	1	
0467132	3/4" FS 90 DEGREE ELBOW	3	
0467394	3/4" FS UNION	2	
65568	3/4" X 5" XH NIPPLE	6	
LP-B112600-3/4	STRAINER 3/4"	1	
MEH225	HYDROSTATIC BRASS 1/4" RELIEF VALVE MPT 440	6	
0490543 0484104	2-1/2" DIAL 0-300 PSI DRY GAUGE	2	
0407928	2-1/2" DIAL 0-30PSI PRESSURE GAUGE	2	
LP-217	Needle Valve 1/4" MALE X 1/4" Female	4	
LP-ME202SS	#54 GAUGE SNUBBER	2	
34BSXHPE	3/4" SCH 80 Pipe XH	30	
TX100	TOREXX 50 GPH ELECTRIC VAPORIZER	1	
114BSTC	1 1/4" X 21' SCH 40 BLACK PIPE (PER FOOT)	30	
0427018	1 1/4" RUB FP VALVE	4	
466206	1 1/4" 90 DEGREE ELBOW	8	
466316	1 1/4" TEE	4	
466265	1-1/4" x 1/2" Reducer Coupling	1	

		Sales Tax (8.875%)
	PLUS ANY APPLICABLE SALES TAX	Total
		12

Edwards Oil, Inc
 820 Hoover Road North
 Virginia, MN 55792
 Phone: 218-741-9634
 sskalko@eoctrimark.com

Date	Estimate #
5/8/2026	5446

Name / Address
AG Obrien 4907 Lightning Drive Duluth, MN 55811

Terms
50% DOWN

THIS ESTIMATE IS NULL AND VOID AFTER 7 DAYS FROM DATE OF ESTIMATE. This estimate is for completing the job as described above. It is based on our evaluation and does not include material price increases or additional labor and material which may be required should unforeseen problems or adverse weather conditions arise after the work has started.

PROJECT
Lakewood - LP

Item	Description	Qty	Cost
66430	1/2" X CL NIPPLE	1	
0467052	1/2" SQ. HEAD SOLID PLUG	1	
91085800	1/2" JOMAR BALL VALVE	1	
4186489	1-1/4" X 1" SWAGE NIPPLE	2	
627-7710	FISHER 1ST STAGE 5-20# PSIG	2	
289H-43	1" FNPT AI 10-20 PSI RELIEF REGULATOR	2	
466382	1 1/4" X 1 1/4" X 1" REDUCING TEE	2	
66346	1 1/4" UNION	6	
48831	TALL SINGLE COLUMN STRUT BASE	2	
48886	2" STRUT CLAMP	1	
48882	3/4" STRUT CLAMP	4	
48884	1-1/4" STRUT CLAMP	6	
11241065	White 1 5/8" Plastic End Cap	10	
48424	1 5/8" X 1-5/8" PRE-GALVANIZED 12GA STEEL HALF SLOT STRUT (PER FOOT)	80	
ME503A-16	3 1/4" M ACME X 2" MPT ADAPTER W/SCREEN	1	
MEP168	CABLE AND CRIMP FERRULE ACME CAPS KIT	2	
ME233	2-1/4" X 1-1/4" ACME ADAPTER	1	
ME431F	2-1/4" CAP	1	
ME441F	3-1/4" CAP	1	
1000990	20LB ABC CLASS FIRE EXTINGUISHER W/WALL HOOK	1	
CUSTOM EMERGENC...	12 X 18 CUSTOM EMERGENCY GAS SHUT OFF	1	
STORAGE-DECALS	STORAGE TANK DECAL SET	2	
45521	AIRCRAFT CABLE (PER FOOT)	75	
0529016	SINGLE SWIVEL EYE PULLEY	5	
RT 45	RT 45 TRENCHING PER FOOT	150	
MISCELLANEOUS SU...	MOB FEE	1	
LP-IPS125	1 1/4" IPS POLY TUBING (PER FOOT)	150	
WIR THHN 14 SOL YEL	TRACER WIRE	160	
FEI75901	1 1/4" IPS PERMASERT RISER W/ MECH. ENDS	3	
0467061	1 1/4" FS SQ. HEAD SOLID PLUG	1	
FEI50327010	1 1/4" IPS PERMA TEE	1	
MISCELLANEOUS SU...	MISCELLANEOUS SUPPLIES		
MISCELLANEOUS SU...	Travel Expense		
LABOR	LABOR		

Sales Tax (8.875%)
Total
13

PLUS ANY APPLICABLE SALES TAX

Edwards Oil, Inc
 820 Hoover Road North
 Virginia, MN 55792
 Phone: 218-741-9634
 sskalko@eoctrimark.com

Date	Estimate #
5/8/2026	5446

Name / Address
AG O'Brien 4907 Lightning Drive Duluth, MN 55811

Terms
50% DOWN

THIS ESTIMATE IS NULL AND VOID AFTER 7 DAYS FROM DATE OF ESTIMATE. This estimate is for completing the job as described above. It is based on our evaluation and does not include material price increases or additional labor and material which may be required should unforeseen problems or adverse weather conditions arise after the work has started.

PROJECT
Lakewood - LP

Item	Description	Qty	Cost
TANK PAINT	PAINTING OF TANK, WHITE, AT FINAL PLACEMENT Exclusions: Electrical By Others, Existing Driveway Work for Fuel Delivery. Project Change Orders from Customer or General Contractor	1	

Pre Tax Total: \$195,645.57
Sales Tax (8.875%) \$17,363.54
Total \$213,009.11



PLUS ANY APPLICABLE SALES TAX

AIA® Document G802® – 2017

Amendment to the Professional Services Agreement

PROJECT: <i>(name and address)</i> Duluth Schools 2025 LTFM Phase 1 Projects	AGREEMENT INFORMATION: Date: July 25, 2025	AMENDMENT INFORMATION: Amendment Number: 001 Date: 04-07-2026
OWNER: <i>(name and address)</i> Duluth Public Schools, ISD #709 709 Portia Johnson Drive Duluth, MN 55811	ARCHITECT: <i>(name and address)</i> ICS Consulting, LLC 1331 Tyler Street N.E., Suite 101 Minneapolis, MN 55413	

The Owner and Architect amend the Agreement as follows:
This Amendment supplements the B132-2019, Standard Form of Agreement Between Owner and Architect, Construction Manager as Adviser Edition, and the C132-2019, Standard Form of Agreement Between Owner and Construction Manager as Adviser, dated July 25, 2025, between Duluth Public Schools, ISD #709 and ICS for the project known as Duluth Schools 2025 LTFM Phase 1 Projects.

General Summary:
This Amendment reallocates the value associated with re-commissioning select HVAC Systems and Equipment from 'Section 5 - Construction Costs' to 'Section 3 - Fees/Services/Budgets' section of the overall project budget summary following MDE guidelines of 0.8% for required project commissioning.

The Architect's compensation and schedule shall be adjusted as follows:

Compensation Adjustment:
Resulting Section 3 - Fees/Services/Budgets adjustment: \$243,200.00
Resulting Section 5 - Construction Costs adjustment: (\$243,200.00)

Total Project Budget: \$38,660,200.00 (no change)

Schedule Adjustment:
N/A

ARCHITECT *(Signature)*

BY: Andy Faulkner, President
(Printed name, title, and license number if required)

Date

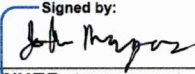
Signed by:

OWNER *(Signature)*

BY: John Magas, Superintendent
(Printed name and title)

5/8/2026

Date

OWNER *(Signature)*

BY: Kelly Durick Eder, School Board Chair

(Printed name and title)

Date

Minimize



Duluth Public Schools

2025 Referendum
ICS Project # TBD

Date Printed 4/13/2026

OVERALL PROJECT SUMMARY						
FUNDING:	ORIGINAL BUDGET	ADJUSTMENTS	REVISED BUDGET WITH ADJUSTMENTS	COST TO DATE	PENDING COSTS / ADJUSTMENTS	BUDGETED COST TO COMPLETE
1 FUNDING SOURCE(S)						
1.01 G.O. Bond Proceeds	\$ 38,660,200	\$ -	\$ 38,660,200	\$ -	\$ -	\$ 38,660,200
TOTAL REVENUE:	\$ 38,660,200	\$ -	\$ 38,660,200	\$ -	\$ -	\$ 38,660,200
COSTS:						
2 PERMITS / OWNER COSTS / OFF SITE COSTS						
2.03 Building Permit / Plan Review	\$ 200,000	\$ -	\$ 200,000	\$ 1,881	\$ -	\$ 198,119
SUBTOTAL:	\$ 200,000	\$ -	\$ 200,000	\$ 1,881	\$ -	\$ 198,119
3 FEES / SERVICES / BUDGETS						
3.01 Program Management Fees	\$ 4,271,200	\$ -	\$ 4,271,200	\$ 667,078	\$ 243,200	\$ 3,360,922
3.02 Program Management Reimbursable	\$ 250,000	\$ -	\$ 250,000	\$ -	\$ -	\$ 250,000
3.03 Construction Phase Site Services	\$ 980,000	\$ -	\$ 980,000	\$ -	\$ -	\$ 980,000
3.04 Site Surveys	\$ 40,000	\$ -	\$ 40,000	\$ -	\$ -	\$ 40,000
3.05 Soil Investigation	\$ 40,000	\$ -	\$ 40,000	\$ -	\$ -	\$ 40,000
3.06 Construction Testing	\$ 150,000	\$ -	\$ 150,000	\$ -	\$ -	\$ 150,000
3.07 Bond Finance/Issuance Costs	\$ 450,000	\$ -	\$ 450,000	\$ -	\$ -	\$ 450,000
3.08 Insurance - Builders Risk	\$ 65,000	\$ -	\$ 65,000	\$ -	\$ -	\$ 65,000
3.09 Legal, Etc.	\$ 50,000	\$ -	\$ 50,000	\$ -	\$ -	\$ 50,000
3.10 Moving / Relocation / Transportation Costs	\$ 150,000	\$ -	\$ 150,000	\$ -	\$ -	\$ 150,000
3.11 Other District Project Expenses	\$ 100,000	\$ -	\$ 100,000	\$ -	\$ -	\$ 100,000
SUBTOTAL:	\$ 6,546,200	\$ -	\$ 6,546,200	\$ 667,078	\$ 243,200	\$ 5,635,922
4 FURNITURE / EQUIPMENT / TECHNOLOGY						
SUBTOTAL:	\$ -	\$ -	\$ -	\$ -	\$ -	\$ -
5 CONSTRUCTION COSTS						
5.01 Re-Cx Solutions	\$ 1,350,000	\$ -	\$ 1,350,000	\$ -	\$ (243,200)	\$ 1,593,200
5.02 Lakewood Elementary Boiler Replacement	\$ 650,000	\$ 245,205	\$ 895,205	\$ -	\$ -	\$ 895,205
5.03 Stowe Elementary Roof Replacement	\$ 3,484,090	\$ -	\$ 3,484,090	\$ -	\$ -	\$ 3,484,090
5.04 Lincoln Park Lighting Updates	\$ 1,800,000	\$ (845,409)	\$ 954,591	\$ 591,537	\$ -	\$ 363,054
5.05 Lowell Elementary School Lighting Updates	\$ 600,000	\$ (55,545)	\$ 544,455	\$ 263,026	\$ -	\$ 281,429
5.06 Denfeld High School	\$ 7,150,000	\$ -	\$ 7,150,000	\$ -	\$ -	\$ 7,150,000
5.07 Lincoln Park Middle School	\$ 800,000	\$ -	\$ 800,000	\$ -	\$ -	\$ 800,000
5.08 East High School	\$ 5,000,000	\$ -	\$ 5,000,000	\$ -	\$ -	\$ 5,000,000
5.09 Ordean East Middle School	\$ 5,100,000	\$ -	\$ 5,100,000	\$ -	\$ -	\$ 5,100,000
5.10 Roofing & Misc. Repair	\$ 3,915,910	\$ 667,986	\$ 4,583,896	\$ -	\$ -	\$ 4,583,896
5.11 General Conditions Allowance	\$ 550,000	\$ -	\$ 550,000	\$ -	\$ -	\$ 550,000
SUBTOTAL:	\$ 30,400,000	\$ 12,236	\$ 30,412,236	\$ 854,563	\$ (243,200)	\$ 29,800,874
6 CONSTRUCTION CONTINGENCY						
6.01 Construction Contingency	\$ 1,500,000	\$ (12,236)	\$ 1,487,764	\$ -	\$ -	\$ 1,487,764
SUBTOTAL:	\$ 1,500,000	\$ (12,236)	\$ 1,487,764	\$ -	\$ -	\$ 1,487,764
TOTAL COSTS:	\$ 38,646,200	\$ (0)	\$ 38,646,200	\$ 1,523,521	\$ -	\$ 37,122,679
OVERALL PROJECT BALANCE:	\$ 14,000					

Social Studies Curriculum Review & Adoption

May Committee of the Whole

Brenda Spartz, Jen Larva, London Goode, Susan Schmidt



Major Shifts in the New Social Studies Standards

- **Increased use of inquiry process**
 - Students will be expected to ask questions, investigate problems and explore topics while teachers support their ability to do this
- **Focus on disciplinary literacy skills**
 - Students will be expected to read, write, speak, perform, and think critically as well as learn the content to master standards
- **Addition of Ethnic Studies strand in all grade levels**
 - K-12 standards that focus on the experience and perspective of people of color in our country and around the world
- **Kindergarten-8th grade interdisciplinary model**
 - The K-8 standards now center around a grade-level themes instead of social studies disciplines (history, economics, etc.)



Social Studies Curriculum Adoption Process

- 2022-2023
 - K-12 Committee analyzed the new standards to learn about changes
- 2023-2024
 - K-12 Committee conducted needs assessment with staff, students, and community members
 - [List of priorities](#) from needs assessment
- 2024-2025
 - K-5 Committee reviewed available social studies resources using [Instructional Resources Evaluation Form](#) and [Equity, Diversity, and Inclusion Form](#)
 - K-6 Committee began revising written curriculum to meet new standards
- 2025-2026
 - K-5 Committee is currently piloted [Studies Weekly](#) and [Exploring Social Studies: Minnesota](#)
 - 6-12 Committee made recommendations for changes to course catalog
 - Provided professional development on new Social Studies standards for teaching staff
 - Teacher committees are revising written curriculum to meet new standards
 - Obtained feedback from District Advisory Committee
- 2026-2027
 - Implementation of 2021 Minnesota Social Studies Standards



Social Studies Curriculum Selection

- K-5 Social Studies Committee Selected [Exploring Social Studies: Minnesota](#)
 - Higher ratings in all categories, especially planning, instruction, assessment, culturally responsive instruction, and social justice
 - Full alignment to the MN Social Studies Standards, including all ethnic studies standards
 - Easier for teachers to implement in limited time
 - Less expensive than other options
 - Publishers consulted with representative from Fond du Lac Band of Lake Superior Chippewa
- 6th Grade Continued Yearly Purchase of Northern Lights
 - Reasons and benefits



Adoption Cost

- Exploring Social Studies: MN (K-5): \$244,989.35*
- Northern Lights (6th Grade): \$9,500
- Total Cost: **\$254,489.35**

*The cost for Exploring Social Studies: MN is a one-time purchase until the next adoption. No yearly consumables or subscription fees are necessary.



Contact Information



Brenda Spartz

Elementary Education
Director
brenda.spartz@isd709.org

Jen Larva

Secondary Education
Director
jen.larva@isd709.org

Dr. Dale Uselman

MTSS / Curriculum & Instruction
Coordinator
dale.uselman@isd709.org

Julie Stauber

MTSS / Curriculum & Instruction
Coordinator
julie.stauber@isd709.org

London Goode

Elementary Social Studies
Content Specialist
london.goode@isd709.org

Susan Schmidt

Secondary Social Studies
Content Specialist
susan.schmidt@isd709.org

Teacher Created Materials

5482 Argosy Ave
Huntington Beach, CA 92649



Created by Teachers for Teachers and Students

Proposal For:
Duluth Public Schools
Proposal #: TCM-00108870
Attn: Dale Uselman

Issued By: Alyssa Wiederhold
Email: alyssa.wiederhold@tcmpub.com
Direct Line: (651) 269-8720
Issue Date: April 14, 2026

Billing Address:
709 Portia Johnson Drive
Duluth, MN 55811

Shipping Address:
709 Portia Johnson Dr
Duluth, MN 55811

Item	Title	Notes:	Qty	Sales Price	Total
29638	Primary Sources: Kindergarten Kit		29	\$219.99	\$6,379.71
111611	Primary Sources: Kindergarten Kit (Spanish)	100% Discounted	3	\$0.00	\$0.00
158898	Exploring Social Studies: Minnesota: Student Inquiry Handbook, Grade K		535	\$16.99	\$9,089.65
158919	Exploring Social Studies: Minnesota: Student Inquiry Handbook, Grade K ebook		535	\$16.99	\$9,089.65
169467	Exploring Social Studies: Minnesota: Grade K: Student Inquiry Handbook (Spanish)		60	\$16.99	\$1,019.40
169485	Exploring Social Studies: Minnesota: Grade K: Student Inquiry Handbook PDF ebook (Spanish)		60	\$16.99	\$1,019.40
158377	Exploring Social Studies: Minnesota: Grade 1		30	\$1,199.99	\$35,999.70
169435	Exploring Social Studies: Minnesota: Grade 1 (Spanish)		3	\$1,199.99	\$3,599.97
158899	Exploring Social Studies: Minnesota: Student Inquiry Handbook, Grade 1		547	\$16.99	\$9,293.53
169468	Exploring Social Studies: Minnesota: Grade 1: Student Inquiry Handbook (Spanish)		63	\$16.99	\$1,070.37
158378	Exploring Social Studies: Minnesota: Grade 2		28	\$1,199.99	\$33,599.72
169436	Exploring Social Studies: Minnesota: Grade 2 (Spanish)		3	\$1,199.99	\$3,599.97
158900	Exploring Social Studies: Minnesota: Student Inquiry Handbook, Grade 2		538	\$16.99	\$9,140.62

Safety Disclaimer

This proposal may contain items not developed or manufactured by or under the direction of TCM. We take seriously the safety ramifications of all our products and will pass along all risk warnings provided by the manufacturers of products not developed by TCM. Such risks may include, but are not limited to suffocation, strangulation, choking, and exposure to sharp objects. Please follow all safety precautions which may include, but are not limited to, keeping hazardous items out of reach, avoiding using cords or strings in risky environments, supervising children when using small parts to prevent choking, and handling sharp objects with care. By proceeding, you accept the risks of any liability, and agree to indemnify, defend, and hold harmless TCM from any liability, including all related fees and costs, for any claim of injury or damage resulting from the alleged improper use or oversight of any products not developed or manufactured by TCM, and from potential risks or side effects that may result from the foreseeable use of any products not developed or manufactured by TCM.

Teacher Created Materials

5482 Argosy Ave
Huntington Beach, CA 92649



Created by Teachers for Teachers and Students

169469	Exploring Social Studies: Minnesota: Grade 2: Student Inquiry Handbook (Spanish)		63	\$16.99	\$1,070.37
158379	Exploring Social Studies: Minnesota: Grade 3		31	\$1,299.99	\$40,299.69
158901	Exploring Social Studies: Minnesota: Student Inquiry Handbook, Grade 3		594	\$16.99	\$10,092.06
158380	Exploring Social Studies: Minnesota: Grade 4		30	\$1,299.99	\$38,999.70
158902	Exploring Social Studies: Minnesota: Student Inquiry Handbook, Grade 4		604	\$16.99	\$10,261.96
158381	Exploring Social Studies: Minnesota: Grade 5	100% Discounted	29	\$0.00	\$0.00
158903	Exploring Social Studies: Minnesota: Student Inquiry Handbook, Grade 5		616	\$16.99	\$10,465.84
131573	Paid Professional Learning (workshop, in-person)	100% Discounted	2	\$0.00	\$0.00
				Subtotal:	\$234,091.31
				Shipping:	\$10,898.04
				Sales Tax:	\$0.00
Please remit orders to: Orders@tcmpub.com or Fax: 888-877-7606				Total:	\$244,989.35

April 15, 2026

Anthony Bonds, Assistant Superintendent
Independent School District 709
4316 Rice Lake Rd, Suite 108
Duluth MN 55811

Dear Mr. Bonds:

This is to certify that the person(s) listed below has completed all the requirements for High School graduation from the Duluth Public Schools and is eligible to receive their diploma from the school listed.

<u>NAME OF GRADUATE</u>	<u>SCHOOL ON DIPLOMA</u>	<u>GRADUATION DATE</u>
Sophia Majchrzak	Duluth Public Schools	4/9/2026

Please send diploma to Kathleen Wilson at the Area Learning Center, Suite 450.

Nathan Glöckle
Principal

Kathleen Wilson
Sr. Clerical
Area Learning Center

MEMORANDUM

TO: Curriculum Dept.
FROM: Angie Frank, Adult Diploma Program
SUBJECT: High School Diploma
DATE: 4/14/2026

The following student completed all requirements for graduation from I.S.D. 709 via the Adult Diploma Program and requests their Duluth Public Schools diploma, dated:

Harlen Brown III

4/14/2026

April 22, 2026

Anthony Bonds, Assistant Superintendent
Independent School District 709
4316 Rice Lake Rd, Suite 108
Duluth MN 55811

Dear Mr. Bonds:

This is to certify that the person(s) listed below has completed all the requirements for High School graduation from the Duluth Public Schools and is eligible to receive their diploma from the school listed.

<u>NAME OF GRADUATE</u>	<u>SCHOOL ON DIPLOMA</u>	<u>GRADUATION DATE</u>
Keeley St. Germaine	Duluth Public Schools	4/16/2026
Jessalyn Little	Duluth Public Schools	4/21/2026
Sawyer Latvala *	Duluth Public Schools	5/14/2026

* The Bridge program request per L Post.

Please send diploma to Kathleen Wilson at the Area Learning Center, Suite 450.

Nathan Glöckle
Principal

Kathleen Wilson
Sr. Clerical
Area Learning Center

MEMORANDUM

TO: Curriculum Dept.
FROM: Angie Frank, Adult Diploma Program
SUBJECT: High School Diploma
DATE: 4/21/2026

The following student completed all requirements for graduation from I.S.D. 709 via the Adult Diploma Program and requests their Duluth Public Schools diploma, dated:

Aaron Kingbird

4/21/2026

MEMORANDUM

TO: Curriculum Dept.
FROM: Angie Frank, Adult Diploma Program
SUBJECT: High School Diploma
DATE: 4/29/26

The following student completed all requirements for graduation from I.S.D. 709 via the Adult Diploma Program and requests their Duluth Public Schools diploma, dated:

Anthony Brown Jr.

4/29/26

April 29, 2026

Anthony Bonds, Assistant Superintendent
Independent School District 709
4316 Rice Lake Rd, Suite 108
Duluth MN 55811

Dear Mr. Bonds:

This is to certify that the person(s) listed below has completed all the requirements for High School graduation from the Duluth Public Schools and is eligible to receive their diploma from the school listed.

<u>NAME OF GRADUATE</u>	<u>SCHOOL ON DIPLOMA</u>	<u>GRADUATION DATE</u>
Samantha A Miller	Duluth Public Schools	4/29/2026

Please send diploma to Kathleen Wilson at the Area Learning Center, Suite 450.

Nathan Glöckle
Principal

Kathleen Wilson
Sr. Clerical
Area Learning Center

May 6, 2026

Anthony Bonds, Assistant Superintendent
Independent School District 709
4316 Rice Lake Rd, Suite 108
Duluth MN 55811

Dear Mr. Bonds:

This is to certify that the person(s) listed below has completed all the requirements for High School graduation from the Duluth Public Schools and is eligible to receive their diploma from the school listed.

<u>NAME OF GRADUATE</u>	<u>SCHOOL ON DIPLOMA</u>	<u>GRADUATION DATE</u>
Aiden Bender	Duluth Public Schools	5/5/2026
Jasiah Jacobs	Duluth Public Schools	5/6/2026
Joseph W Wise	Duluth Public Schools	5/6/2026
Dominic Nguyen	Duluth Public Schools	5/6/2026
Nathaniel Solem	Duluth Public Schools	5/6/2026

Please send diploma to Kathleen Wilson at the Area Learning Center, Suite 450.

Nathan Glöckle
Principal

Kathleen Wilson
Sr. Clerical
Area Learning Center

May 12, 2026

Anthony Bonds, Assistant Superintendent
Independent School District 709
4316 Rice Lake Rd, Suite 108
Duluth MN 55811

Dear Mr. Bonds:

This is to certify that the person(s) listed below has completed all the requirements for High School graduation from the Duluth Public Schools and is eligible to receive their diploma from the school listed.

<u>NAME OF GRADUATE</u>	<u>SCHOOL ON DIPLOMA</u>	<u>GRADUATION DATE</u>
Kennidee Becker	Duluth Public Schools	5/11/2026
Winter Shelafoe	Duluth Public Schools	5/11/2026

Please send diploma to Kathleen Wilson at the Area Learning Center, Suite 450.

Nathan Glöckle
Principal

Kathleen Wilson
Sr. Clerical
Area Learning Center

ROCKRIDGE ACADEMY

4849 Ivanhoe Street

Phone: (218) 336-8955 ~ Fax: (218) 336-8959

May 13th, 2026

John Magas
Ind. School District 709
4316 Rice Lake Road, Suite 108
Duluth, MN 55811

Dear Mr. Magas,

This is to certify that the person listed below has completed all the requirements for High School graduation from the Duluth Public Schools and is eligible to receive his diploma from the school listed.

<u>Name of Graduate</u>	<u>School</u>	<u>Graduation Date</u>
Maya Chereen Rose Smith	Rockridge Academy	May 29th, 2026

Thank you

Jacob Hintsala
Principal

May 6, 2026

Anthony Bonds, Assistant Superintendent
Independent School District 709
4316 Rice Lake Rd, Suite 108
Duluth MN 55811

Dear Mr. Bonds:

This is to certify that the person(s) listed below has completed all the requirements for High School graduation from the Duluth Public Schools and is eligible to receive their diploma from the school listed.

<u>NAME OF GRADUATE</u>	<u>SCHOOL ON DIPLOMA</u>	<u>GRADUATION DATE</u>
James Pfuhl *	Duluth Public Schools	5/20/2026

As requested by Lisa Post/Bridge Program.

Please send diploma to Kathleen Wilson at the Area Learning Center, Suite 450.

Nathan Glöckle
Principal

Kathleen Wilson
Sr. Clerical
Area Learning Center

MEMORANDUM

TO: Curriculum Dept.
FROM: Angie Frank, Adult Diploma Program
SUBJECT: High School Diploma
DATE: 5/6/2026

The following student completed all requirements for graduation from I.S.D. 709 via the Adult Diploma Program and requests their Duluth Public Schools diploma, dated:

Jeanette Barber

5/6/2026

MEMORANDUM

TO: Curriculum Dept.
FROM: Angie Frank, Adult Diploma Program
SUBJECT: High School Diploma
DATE: 5/6/2026

The following student completed all requirements for graduation from I.S.D. 709 via the Adult Diploma Program and requests their Duluth Public Schools diploma, dated:

Anthony Elke

5/6/2026

MEMORANDUM

TO: Curriculum Dept.
FROM: Angie Frank, Adult Diploma Program
SUBJECT: High School Diploma
DATE: 5/6/2026

The following student completed all requirements for graduation from I.S.D. 709 via the Adult Diploma Program and requests their Duluth Public Schools diploma, dated:

Jaimee Cahoon

5/6/2026

PRINT SHOP ORDER FOR CALLIGRAPHY

ORDERED BY: Shannon Brown - Asst Supt Office

DATE: 5/12/2026

DATE NEEDED: ASAP

CALLIGRAPHY ON DIPLOMAS AS FOLLOWS:

<u>Student Name</u>	<u>Date of Graduation</u>	<u>School</u>	<u>Return to</u>
Liberty Hunt	5/28/26	Denfeld High School	Tracy R

PRINT SHOP ORDER FOR CALLIGRAPHY

ORDERED BY: Shannon Brown - Asst Supt Office

DATE: 5/7/2026

DATE NEEDED: ASAP

CALLIGRAPHY ON DIPLOMAS AS FOLLOWS:

<u>Student Name</u>	<u>Date of Graduation</u>	<u>School</u>	<u>Return to</u>
Nina M Koop	5/28/26	East High School	Jodi G

PRINT SHOP ORDER FOR CALLIGRAPHY

ORDERED BY: Shannon Brown - Asst Supt Office

DATE: 5/7/2026

DATE NEEDED: ASAP

CALLIGRAPHY ON DIPLOMAS AS FOLLOWS:

<u>Student Name</u>	<u>Date of Graduation</u>	<u>School</u>	<u>Return to</u>
Ruby Derrick	6/5/2024	East High School	Jodi G

April 16, 2026

Anthony Bonds, Assistant Superintendent
Independent School District 709
709 Portia Johnson Dr
Duluth MN 55811

Dear Mr. Bonds:

This is to certify that the person(s) listed below has completed all the requirements for High School graduation from the Duluth Public Schools and is eligible to receive their diploma from the school listed.

<u>NAME OF GRADUATE</u>	<u>SCHOOL ON DIPLOMA</u>	<u>GRADUATION DATE</u>
Tanis M. Halverson	Duluth Public Schools	06/02/2026

Please send diploma to ***Darcy Motschenbacher at East High school for Kelly Flohaug*** to sign with a note to send interschool mail to Jennifer Fabbro, Arvig Bldg, DAE office once they are completed.

****If you could also send the Duluth School diploma folder, it would be appreciated.**

Kelly Flohaug
Principal

Jennifer Fabbro
Transition 12 Teacher
Arvig building, Suite 310

Send to Valerie Wagenbach

April 16, 2026

Anthony Bonds, Assistant Superintendent
Independent School District 709
709 Portia Johnson Dr
Duluth MN 55811

Dear Mr. Bonds:

This is to certify that the person(s) listed below has completed all the requirements for High School graduation from the Duluth Public Schools and is eligible to receive their diploma from the school listed.

<u>NAME OF GRADUATE</u>	<u>SCHOOL ON DIPLOMA</u>	<u>GRADUATION DATE</u>
Tashyna Rayawna Holmes	Denfeld High School	06/02/2026

Please send diploma to Tracey Robertson at Denfeld High school for Thomas Tusken to sign with a *note to send interschool mail to Jennifer Fabbro, Arvig Bldg, DAE office* once they are completed.

Thomas Tusken
Principal

Jennifer Fabbro
Transition 12 Teacher
Arvig building, Suite 310

April 16, 2026

Anthony Bonds, Assistant Superintendent
Independent School District 709
709 Portia Johnson Dr
Duluth MN 55811

Dear Mr. Bonds:

This is to certify that the person(s) listed below has completed all the requirements for High School graduation from the Duluth Public Schools and is eligible to receive their diploma from the school listed.

<u>NAME OF GRADUATE</u>	<u>SCHOOL ON DIPLOMA</u>	<u>GRADUATION DATE</u>
Quin Salvador Nolan	East High School	06/02/2026

Please send diploma to Darcy Motschenbacher at East High school for Kelly Flohaug to sign with a note to send interschool mail to Jennifer Fabbro, Arvig Bldg, DAE office once they are completed.

**If you could also send the East High School diploma folder, it would be appreciated.

Kelly Flohaug
Principal

Jennifer Fabbro
Transition 12 Teacher
Arvig building, Suite 310

April 16, 2026

Anthony Bonds, Assistant Superintendent
Independent School District 709
709 Portia Johnson Dr
Duluth MN 55811

Dear Mr. Bonds:

This is to certify that the person(s) listed below has completed all the requirements for High School graduation from the Duluth Public Schools and is eligible to receive their diploma from the school listed.

<u>NAME OF GRADUATE</u>	<u>SCHOOL ON DIPLOMA</u>	<u>GRADUATION DATE</u>
Hannah Rose Lamphier	East High School	06/02/2026

Please send diploma to Darcy Motschenbacher at East High school for Kelly Flohaug to sign with a note to send interschool mail to Jennifer Fabbro, Arvig Bldg, DAE office once they are completed.

**If you could also send the East High School diploma folder, it would be appreciated.

Kelly Flohaug
Principal

Jennifer Fabbro
Transition 12 Teacher
Arvig building, Suite 310

**DISTRICT 709
FIELD TRIP REQUESTS**

Heidi B.

In accordance with School District Policy District 6160, District 709 recognizes properly planned, well conducted, and carefully supervised field trips may be a vital part of the curriculum. School field trips are encouraged within available resources and requirements outlined below.

DIRECTIONS: All staff are required to submit a Field Trip Request prior to the field trip being finalized with the involved students and to:

- Receive administrative and/or extra-curricular coordinator approval for all instructional and supplementary field trips
- Receive administrative reviewal and school board approval for all extended trips (Exceptions may be granted by the school board chair to accommodate emergencies.)

DEFINITIONS:

Instructional Trips - Trips that take place during the school day, relate directly to a course of study, and require student participation. Fees may not be assessed against students.

Supplementary Trips - Trips in which students voluntarily participate in and which often take place outside the regular school day, but do not include overnight stays. Financial contributions may be requested of students.

Extended Trips Within Minnesota and Continental United States - Trips that involve one or more overnight stops within Minnesota or the Continental United States and may be instructional or supplementary and are voluntary in nature. Extended field trips require school board approval prior to the trip.

INSTRUCTIONAL TRIP ACTION

Principal: Approved Name: _____
 Not Approved Date: _____

SUPPLEMENTAL TRIP ACTION

Principal: Approved Name: _____
 Not Approved Date: _____

Instructional/Supplemental Trips need not be sent to District office.

EXTENDED TRIP ACTION

Principal: Recommended Name: *Kevin Tolson*
 Not Recommended Date: *4-22-24*

Assistant Superintendent: Recommended Name: *Anthony Borl*
 Not Recommended Date: *5/12/24*

School Board: Approved Name: _____
 Not Approved Date: _____

All extended trip proposals must be sent to the Assistant Superintendent's Office to be placed on the Education Committee meeting agenda for approval.

FIELD TRIP REQUEST FORM

Date of Submission:

Type of Trip: Instructional Supplementary Extended

1. Organization/Grade/Course Planning Trip: Yearbook Camp
2. Contact Person (Responsible for Checklist Completion): _____
3. Field Trip Date(s): June 24-25, 2026 Destination: Eastview High School, Apple Valley
4. Field Trip Overview (Include events, establishments and locations): Journalism workshop for planning 2026-27 yearbook
5. Field Trip Departure from School (Date and Time): 5 AM, June 24
Field Trip Return to School (Date and Time): 9 PM, June 25
6. Objectives of Field Trip: Journalism training: leadership, planning, coverage, photography, sales, teambuilding, theme
7. Relationship to Curriculum or Student Learning: This is the training the yearbook editors need to lead next year's staff.
8. Planned Follow-up Field Trip Activities: debriefing, summer planning

9. Field Trip Budget Request

Estimated Expenses	
Total Admission/Fees	\$ 950
Total Meals	\$
Total Lodging	\$ 800
Total Transportation	\$
<input checked="" type="checkbox"/> School District Vehicle(s)	
<input type="checkbox"/> Commercial Transportation Carrier ~ Name: _____	
<input type="checkbox"/> Private Vehicle (requires certificate of insurance) ~ Name: _____	
Total Additional Stipends:	\$
Other:	\$
Total	\$

Revenues	
District Budget	\$
Code: _____	
Booster Group	\$
Donations	\$
Student Fees	\$
Total Additional Stipends:	\$
Total	\$

Coming from yearbook account.

11. Reviewed/Completed Request Checklist: Yes No

RETURN COMPLETED REQUEST TO BUILDING PRINCIPAL

FIELD TRIP REQUEST CHECKLIST - All Field Trips

DIRECTIONS: Please complete checklist. No attachments are necessary.

- Develop and Communicate Student Discipline Expectations
- Forward Field Trip Explanation and Fee Structure Letter Sent to Parents/Guardians
- Collect Parent/Guardian Permission for Student Participation in Field Trip (Include request for special information - i.e. allergies, medications, special needs.)
- Gain Access to Cell Phone for Field Trip
- Plan Arrangements for Early Pick-Up or Late Drop-Off Students (if necessary).
Guide: May choose to leave message on school voice mail to help with late drop off.
- Plan Meal Arrangements (if necessary)
Reminder: Notify food service of non-participation.
- Plan Administration of Student Medication and First Aid Needs (if necessary)
Guide: Contact School Nurse.
- Develop and Communicate Action Plan if Student Gets Lost on Trip
- Arrange Adult Chaperones for Field Trip (if necessary)
Guide: One (1) adult for every twenty (20) students depending on field trip. Parent volunteers are encouraged when possible or appropriate.
- Develop and Communicate Teacher and Adult Chaperone Expectations
Example: Supervision duties, no smoking, no alcohol
- Planned Itinerary

TIME

LOCATION

7:30 A.M.
8 AM - 5 PM
9:00 PM approx
5 AM

Eastview High School, registration
" " " " camp both days
Return to East H.S.
Pickup @ East H.S.

- Maintain Student Roster and Check-in/Check-out Procedure
- Arrangement for Safety Needs (i.e. crossing guards)

Signature of Contact Person: _____

Judith Bohmann

FIELD TRIP REQUEST CHECKLIST - Extended Trip Only

DIRECTIONS: Please complete checklist and attach all appropriate materials.

- Develop and Complete Field Trip Itinerary and Emergency Telephone Contacts Letter to Parents/Guardians
Note: Attach tentative planned itinerary.
- Arrange Funding of Expenses During Trip
- Arrange Meal Plans
- Arrange Lodging Plans and Room Assignments
- Collect Family Emergency Information for Students
Example: Home phone numbers, emergency contacts, medical information
- Additional Information
Note: Provide any additional information.

Signature of Contact Person: _____

Judith Bohmann

306 ADMINISTRATOR CODE OF ETHICS

I. PURPOSE

The purpose of this policy is to establish the requirements of the school board that school administrators adhere to the standards of ethics and professional conduct in this policy and Minnesota law.

II. GENERAL STATEMENT OF POLICY

The standards of professional conduct are as follows:

- A. A school administrator must provide professional educational services in a nondiscriminatory manner.
- B. A school administrator must take reasonable action to protect students and staff from conditions harmful to health and safety.
- C. A school administrator must take reasonable action to provide an atmosphere conducive to learning.
- D. A school administrator must not use professional relationships with students, parents and caregivers, staff, or colleagues to private advantage.
- E. A school administrator must disclose confidential information about individuals only when a compelling professional purpose is served in accordance with state and federal laws and school district policies.
- F. A school administrator must not knowingly falsify or misrepresent records or facts relating to the administrator's qualifications or to the qualifications of other staff or personnel.
- G. A school administrator must not knowingly make false or malicious statements about students, students' families, staff, or colleagues.
- H. A school administrator must not accept gratuities, gifts, or favors that impair professional judgment, nor offer any favor, service, or item of value to obtain special advantage.
- I. A school administrator must only accept a contract for a position when licensed for the position or when a school district is issued a variance by the Minnesota Board of School Administrators.
- J. A school administrator, in filling positions requiring licensure, must employ, recommend for employment, and assign only appropriately licensed personnel, or persons for whom the school district has been issued a variance by the appropriate state board or agency, unless, after making reasonable efforts to obtain a variance, an appropriately licensed person cannot be assigned and the position must be filled to meet a legitimate emergency educational need.
- K. A school administrator must not engage in conduct involving dishonesty, fraud, or misrepresentation in the performance of professional duties.

Legal References: Minn. Stat. § 122A.14, Subd. 4 (Duties of Board of School Administrators)
Minn. Rules Part 3512.0100 (Definitions)
Minn. Rules Part 3512.5200 (Code of Ethics for School Administrators)

Cross References: None

First Reading: 10.21.2025
Second Reading: 11.13.2025
Adopted: 11.18.2025
Revised: 05.19.2026

306 ADMINISTRATOR CODE OF ETHICS

I. PURPOSE

The purpose of this policy is to establish the requirements of the school board that school administrators adhere to the standards of ethics and professional conduct in this policy and Minnesota law.

II. GENERAL STATEMENT OF POLICY

The standards of professional conduct are as follows:

- A. A school administrator must provide professional educational services in a nondiscriminatory manner.
- B. A school administrator must take reasonable action to protect students and staff from conditions harmful to health and safety.
- C. A school administrator must take reasonable action to provide an atmosphere conducive to learning.
- D. A school administrator must not use professional relationships with students, parents and caregivers, staff, or colleagues to private advantage.
- E. A school administrator must disclose confidential information about individuals only when a compelling professional purpose is served in accordance with state and federal laws and school district policies.
- F. A school administrator must not knowingly falsify or misrepresent records or facts relating to the administrator's qualifications or to the qualifications of other staff or personnel.
- G. A school administrator must not knowingly make false or malicious statements about students, students' families, staff, or colleagues.
- H. A school administrator must not accept gratuities, gifts, or favors that impair professional judgment, nor offer any favor, service, or item of value to obtain special advantage.
- I. A school administrator must only accept a contract for a position when licensed for the position or when a school district is issued a variance by the Minnesota Board of School Administrators.
- J. A school administrator, in filling positions requiring licensure, must employ, recommend for employment, and assign only appropriately licensed personnel, or persons for whom the school district has been issued a variance by the appropriate state board or agency, unless, after making reasonable efforts to obtain a variance, an appropriately licensed person cannot be assigned and the position must be filled to meet a legitimate emergency educational need.
- K. A school administrator must not engage in conduct involving dishonesty, fraud, or misrepresentation in the performance of professional duties.

~~A. An educational administrator's professional behavior must conform to an ethical code. The code must be idealistic and at the same time practical, so that it can apply reasonably to all educational administrators. The administrator acknowledges that the schools belong to the public they serve for the purpose of providing educational opportunities to all. However, the administrator assumes responsibility for providing professional leadership in the school and community. This responsibility requires the administrator to maintain standards of exemplary professional conduct. It must be recognized that the administrator's actions will be viewed and appraised by the community, professional associates, and students. To these ends, the administrator must subscribe to the following standards.~~

~~B. The Educational Administrator:~~

- ~~1. Makes the well-being of students the fundamental value of all decision-making and actions.~~
- ~~2. Fulfills professional responsibilities with honesty and integrity.~~
- ~~3. Supports the principle of due process and protects the civil and human rights of all individuals.~~
- ~~4. Obeys local, state, and national laws and does not knowingly join or support organizations that advocate, directly or indirectly, the overthrow of the government.~~
- ~~5. Implements the school board's policies.~~
- ~~6. Pursues appropriate measures to correct those laws, policies, and regulations that are not consistent with sound educational goals.~~
- ~~7. Avoids using positions for personal gain through political, social, religious, economic, or other influence.~~
- ~~8. Accepts academic degrees or professional certification only from duly accredited institutions.~~
- ~~9. Maintains the standards and seeks to improve the effectiveness of the profession through research and continuing professional development.~~
- ~~10. Honors all contracts until fulfillment, release, or dissolution is mutually agreed upon by all parties to the contract.~~
- ~~11. Adheres to the Code of Ethics for School Administrators in Minnesota Rule.~~

Legal References: Minn. Stat. § 122A.14, Subd. 4 (Duties of Board of School Administrators)
Minn. Rules Part 3512.0100 (Definitions)
Minn. Rules Part 3512.5200 (Code of Ethics for School Administrators)

Cross References: None

First Reading: 10.21.2025
Second Reading: 11.13.2025
Adopted: 11.18.2025
Revised:

306 - 2 of 2

413 HARASSMENT AND VIOLENCE

I. PURPOSE

The purpose of this policy is to maintain a learning and working environment free from harassment and violence on the basis of race, color, creed, religion, national origin, sex, age, marital status, familial status, status with regard to public assistance, sexual orientation, or disability (Protected Class).

II. GENERAL STATEMENT OF POLICY

- A. The policy of the school district is to maintain a learning and working environment free from harassment and violence on the basis of Protected Class. The school district prohibits any form of harassment or violence on the basis of Protected Class. Harassment and violence of any kind towards any individual is prohibited in Duluth Public Schools.
- B. A violation of this policy occurs when any student, teacher, administrator, or other school district personnel harasses a student, teacher, administrator, or other school district personnel or group of students, teachers, administrators, or other school district personnel through conduct or communication based on a person's Protected Class, as defined by this policy. (For purposes of this policy, school district personnel include school board members, school employees, agents, volunteers, contractors, or persons subject to the supervision and control of the district.)
- C. A violation of this policy occurs when any student, teacher, administrator, or other school district personnel inflicts, threatens to inflict, or attempts to inflict violence upon any student, teacher, administrator, or other school district personnel or group of students, teachers, administrators, or other school district personnel based on a person's Protected Class.
- D. The school district will act to investigate all complaints, either formal or informal, verbal or written, of harassment or violence based on a person's Protected Class, and to discipline or take appropriate action against any student, teacher, administrator, or other school district personnel found to have violated this policy.

III. DEFINITIONS

- A. "Assault" is:
 - 1. an act done with intent to cause fear in another of immediate bodily harm or death;
 - 2. the intentional infliction of or attempt to inflict bodily harm upon another; or
 - 3. the threat to do bodily harm to another with present ability to carry out the threat.
- B. "Harassment" prohibited by this policy consists of physical or verbal conduct, including, but not limited to, electronic communications, relating to an individual's or group of individuals' race, color, creed, religion, national origin, sex, age, marital status, familial status, status with regard to public assistance, sexual orientation, including gender identity or expression, or disability, when the conduct:
 - 1. has the purpose or effect of creating an intimidating, hostile, or offensive working or academic environment;

2. has the purpose or effect of substantially or unreasonably interfering with an individual's work or academic performance; or
 3. otherwise adversely affects an individual's employment or academic opportunities.
- C. "Immediately" means as soon as possible but in no event longer than 24 hours.
- D. Protected Classifications
1. "Disability" means, with respect to an individual who
 - a. has a physical sensory or mental impairment that materially limits one or more major life activities of such individual;
 - b. has a record of such an impairment;
 - c. is regarded as having such an impairment; or
 - d. has an impairment that is episodic or in remission and would materially limit a major life activity when active.
 2. "Familial status" means the condition of one or more minors having legal status or custody with:
 - a. the minor's parent or parents or the minor's legal guardian or guardians; or
 - b. the designee of the parent or parents or guardian or guardians with the written permission of the parent or parents or guardian or guardians. Familial status also means residing with and caring for one or more individuals who lack the ability to meet essential requirements for physical health, safety, or self-care because the individual or individuals are unable to receive and evaluate information or make or communicate decisions. The protections afforded against harassment or discrimination on the basis of family status apply to any person who is pregnant or is in the process of securing legal custody of an individual who has not attained the age of majority.
 3. "Marital status" means whether a person is single, married, remarried, divorced, separated, or a surviving spouse and, in employment cases, includes protection against harassment or discrimination on the basis of the identity, situation, actions, or beliefs of a spouse or former spouse.
 4. "National origin" means the place of birth of an individual or of any of the individual's lineal ancestors.
 5. "Sex" includes, but is not limited to, pregnancy, childbirth, and disabilities related to pregnancy or childbirth.
 6. "Sexual orientation" means to whom someone is, or is perceived of as being, emotionally, physically, or sexually attracted to based on sex or gender identity. A person may be attracted to men, women, both, neither, or to people who are genderqueer, androgynous, or have other gender identities.

7. "Status with regard to public assistance" means the condition of being a recipient of federal, state, or local assistance, including medical assistance, or of being a tenant receiving federal, state, or local subsidies, including rental assistance or rent supplements.
- E. "Remedial response" means a measure to stop and correct acts of harassment or violence, prevent acts of harassment or violence from recurring, and protect, support, and intervene on behalf of a student who is the target or victim of acts of harassment or violence.
 - F. Sexual Harassment
 1. Sexual harassment includes unwelcome sexual advances, requests for sexual favors, sexually motivated physical conduct, or other verbal or physical conduct or communication of a sexual nature when:
 - a. submission to that conduct or communication is made a term or condition, either explicitly or implicitly, of obtaining employment or an education; or
 - b. submission to or rejection of that conduct or communication by an individual is used as a factor in decisions affecting that individual's employment or education; or
 - c. that conduct or communication has the purpose or effect of substantially interfering with an individual's employment or education, or creating an intimidating, hostile, or offensive employment or educational environment.
 2. Sexual harassment may include, but is not limited to:
 - a. unwelcome verbal harassment or abuse;
 - b. unwelcome pressure for sexual activity;
 - c. unwelcome, sexually motivated, or inappropriate patting, pinching, or physical contact, other than necessary restraint of student(s) by teachers, administrators, or other school district personnel to avoid physical harm to persons or property;
 - d. unwelcome sexual behavior or words, including demands for sexual favors, accompanied by implied or overt threats concerning an individual's employment or educational status;
 - e. unwelcome sexual behavior or words, including demands for sexual favors, accompanied by implied or overt promises of preferential treatment with regard to an individual's employment or educational status; or
 - f. unwelcome behavior or words directed at an individual because of sexual orientation, including gender identity or expression.

G. Sexual Violence

1. Sexual violence is a physical act of aggression or force or the threat thereof that involves the touching of another's intimate parts or forcing a person to touch any person's intimate parts. Intimate parts, as defined in Minnesota Statutes, section 609.341, includes the primary genital area, groin, inner thigh, buttocks, or breast, as well as the clothing covering these areas.
2. Sexual violence may include, but is not limited to:
 - a. touching, patting, grabbing, or pinching another person's intimate parts
 - b. coercing, forcing, or attempting to coerce or force the touching of anyone's intimate parts;
 - c. coercing, forcing, or attempting to coerce or force sexual intercourse or a sexual act on another; or
 - d. threatening to force or coerce sexual acts, including the touching of intimate parts or intercourse, on another.

H. Violence

Violence prohibited by this policy is a physical act of aggression or assault upon another or group of individuals because of, or in a manner reasonably related to an individual's Protected Class.

IV. REPORTING PROCEDURES

- A. Any person who believes he or she has been the target or victim of harassment or violence on the basis of Protected Class by a student, teacher, administrator, or other school district personnel, or any person with knowledge or belief of conduct which may constitute harassment or violence prohibited by this policy toward a student, teacher, administrator, or other school district personnel or group of students, teachers, administrators, or other school district personnel should report the alleged acts immediately to an appropriate school district official designated by this policy. A person may report conduct that may constitute harassment or violence anonymously. If you choose to report anonymously, you will not be informed once an investigation is complete. However, the school district may not rely solely on an anonymous report to determine discipline or other remedial responses.
- B. The school district encourages the reporting party or complainant to use the report form available from the principal or building supervisor of each building or available from the school district office, but oral reports shall be considered complaints as well.
- C. Nothing in this policy shall prevent any person from reporting harassment or violence directly to a school district human rights officer or to the superintendent. If the complaint involves the building report taker, the complaint shall be made or filed directly with the superintendent or the school district human rights officer by the reporting party or complainant.
- D. In Each School Building

The building principal, the principal's designee, or the building supervisor (hereinafter the "building report taker") is the person responsible for receiving oral or written reports of harassment or violence prohibited by this policy at the building level. Any adult school district personnel who receives a report of harassment or violence prohibited by this policy shall inform the building report taker immediately. If the

complaint involves the building report taker, the complaint shall be made or filed directly with the superintendent or the school district human rights officer by the reporting party or complainant. The building report taker shall ensure that this policy and its procedures, practices, consequences, and sanctions are fairly and fully implemented and shall serve as a primary contact on policy and procedural matters.

- E. A teacher, school administrator, volunteer, contractor, or other school employee shall be particularly alert to possible situations, circumstances, or events that might include acts of harassment or violence. Any such person who witnesses, observes, receives a report of, or has other knowledge or belief of conduct that may constitute harassment or violence shall make reasonable efforts to address and resolve the harassment or violence and shall inform the building report taker immediately. School district personnel who fail to inform the building report taker of conduct that may constitute harassment or violence or who fail to make reasonable efforts to address and resolve the harassment or violence in a timely manner may be subject to disciplinary action.
- F. Upon receipt of a report, the building report taker must notify the school district human rights officer immediately, without screening or investigating the report. The building report taker may request, but may not insist upon, a written complaint. A written statement of the facts alleged will be forwarded as soon as practicable by the building report taker to the human rights officer. If the report was given verbally, the building report taker shall personally reduce it to written form within 24 hours and forward it to the human rights officer. Failure to forward any harassment or violence report or complaint as provided herein may result in disciplinary action against the building report taker.
- G. In the District

The school board hereby designates Steven Johnson, Director of Human Resources, steven.johnson2@isd709.org as the school district human rights officer(s) to receive reports or complaints of harassment or violence prohibited by this policy. If the complaint involves a human rights officer, the complaint shall be filed directly with the superintendent.
- H. The school district shall conspicuously post the name of the human rights officer(s), including mailing addresses and telephone numbers.
- I. Submission of a good faith complaint or report of harassment or violence prohibited by this policy will not affect the complainant or reporter's future employment, grades, work assignments, or educational or work environment.
- J. Use of formal reporting forms is not mandatory.
- K. Reports of harassment or violence prohibited by this policy are classified as private educational and/or personnel data and/or confidential investigative data and will not be disclosed except as permitted by law.
- L. The school district will respect the privacy of the complainant(s), the individual(s) against whom the complaint is filed, and the witnesses as much as possible, consistent with the school district's legal obligations to investigate, to take appropriate action, and to comply with any discovery or disclosure obligations.
- M. Retaliation against a victim, good faith reporter, or a witness of violence or harassment is prohibited.
- N. False accusations or reports of violence or harassment against another person are prohibited.

- O. A person who engages in an act of violence or harassment, reprisal, retaliation, or false reporting of violence or harassment, or permits, condones, or tolerates violence or harassment shall be subject to discipline or other remedial responses for that act in accordance with the school district's policies and procedures.

Consequences for students who commit, or are a party to, prohibited acts of violence or harassment or who engage in reprisal or intentional false reporting may range from remedial responses or positive behavioral interventions up to and including suspension and/or expulsion.

Consequences for employees who permit, condone, or tolerate violence or harassment or engage in an act of reprisal or intentional false reporting of violence or harassment may result in disciplinary action up to and including termination or discharge.

Consequences for other individuals engaging in prohibited acts of violence or harassment may include, but not be limited to, exclusion from school district property and events and/or termination of services and/or contracts.

V. INVESTIGATION

- A. By authority of the school district, the human rights officer, within three (3) days of the receipt of a report or complaint alleging harassment or violence prohibited by this policy, shall undertake or authorize an investigation. The investigation may be conducted by school district officials or by a third party designated by the school district.
- B. The investigation may consist of personal interviews with the complainant, the individual(s) against whom the complaint is filed, and others who may have knowledge of the alleged incident(s) or circumstances giving rise to the complaint. The investigation may also consist of any other methods and documents deemed pertinent by the investigator.
- C. In determining whether alleged conduct constitutes a violation of this policy, the school district should consider the surrounding circumstances, the nature of the behavior, past incidents or past or continuing patterns of behavior, the relationships between the parties involved, and the context in which the alleged incidents occurred. Whether a particular action or incident constitutes a violation of this policy requires a determination based on all the facts and surrounding circumstances.
- D. In addition, the school district may take immediate steps, at its discretion, to protect the target or victim, the complainant, and students, teachers, administrators, or other school district personnel pending completion of an investigation of alleged harassment or violence prohibited by this policy.
- E. The alleged perpetrator of the act(s) of harassment or violence shall be allowed the opportunity to present a defense during the investigation or prior to the imposition of discipline or other remedial responses.
- F. The investigation will be completed as soon as practicable. The school district human rights officer shall make a written report to the superintendent upon completion of the investigation. If the complaint involves the superintendent, the report may be filed directly with the school board. The report shall include a determination of whether the allegations have been substantiated as factual and whether they appear to be violations of this policy.

VI. SCHOOL DISTRICT ACTION

- A. Upon completion of an investigation that determines a violation of this policy has occurred, the school district will take appropriate action. Such action may include, but is not limited to, warning, suspension, exclusion, expulsion, transfer, remediation, termination, or discharge. Disciplinary consequences will be sufficiently severe to try to deter violations and to appropriately discipline prohibited behavior. School district action taken for violation of this policy will be consistent with requirements of applicable collective bargaining agreements, Minnesota and federal law, and applicable school district policies and regulations.
- B. The school district is not authorized to disclose to a victim private educational or personnel data regarding an alleged perpetrator who is a student or employee of the school district. School officials will notify the targets or victims and alleged perpetrators of harassment or violence, the parent(s) or guardian(s) of targets or victims of harassment or violence and the parent(s) or guardian(s) of alleged perpetrators of harassment or violence who have been involved in a reported and confirmed harassment or violence incident of the remedial or disciplinary action taken, to the extent permitted by law.
- C. In order to prevent or respond to acts of harassment or violence committed by or directed against a child with a disability, the school district shall, where determined appropriate by the child's individualized education program (IEP) or Section 504 team, allow the child's IEP or Section 504 plan to be drafted to address the skills and proficiencies the child needs as a result of the child's disability to allow the child to respond to or not to engage in acts of harassment or violence.

VII. RETALIATION OR REPRISAL

The school district will discipline or take appropriate action against any student, teacher, administrator, or other school district personnel who commits an act of reprisal or who retaliates against any person who asserts, alleges, or makes a good faith report of alleged harassment or violence prohibited by this policy, who testifies, assists, or participates in an investigation of retaliation or alleged harassment or violence, or who testifies, assists, or participates in a proceeding or hearing relating to such harassment or violence. Retaliation includes, but is not limited to, any form of intimidation, reprisal, harassment, or intentional disparate treatment. Disciplinary consequences will be sufficiently severe to deter violations and to appropriately discipline the individual(s) who engaged in the harassment or violence. Remedial responses to the harassment or violence shall be tailored to the particular incident and nature of the conduct.

VIII. RIGHT TO ALTERNATIVE COMPLAINT PROCEDURES

These procedures do not deny the right of any individual to pursue other avenues of recourse which may include filing charges with the Minnesota Department of Human Rights or another state or federal agency, initiating civil action, or seeking redress under state criminal statutes and/or federal law.

IX. HARASSMENT OR VIOLENCE AS ABUSE

- A. Under certain circumstances, alleged harassment or violence may also be possible abuse under Minnesota law. If so, the duties of mandatory reporting under Minnesota Statutes, chapter 260E may be applicable.
- B. Nothing in this policy will prohibit the school district from taking immediate action to protect victims of alleged harassment, violence, or abuse.

X. DISSEMINATION OF POLICY AND TRAINING

- A. This policy shall be conspicuously posted throughout each school building in areas accessible to students and staff members.
- B. This policy shall be given to each school district employee and independent contractor who regularly interacts with students at the time of initial employment with the school district.
- C. This policy shall appear in the student handbook.
- D. The school district will develop a method of discussing this policy with students and employees.
- E. The school district may implement violence prevention and character development education programs to prevent and reduce policy violations. Such programs may offer instruction on character education including, but not limited to, character qualities such as attentiveness, truthfulness, respect for authority, diligence, gratefulness, self-discipline, patience, forgiveness, respect for others, peacemaking, resourcefulness, and/or sexual abuse prevention.
- F. This policy shall be reviewed at least annually for compliance with state and federal law.

Legal References: Minn. Stat. § 120B.232 (Character Development Education)
Minn. Stat. § 120B.234 (Child Sexual Abuse Prevention Education)
Minn. Stat. § 121A.03, Subd. 2 (Sexual, Religious, and Racial Harassment and Violence Policy)
Minn. Stat. § 121A.031 (School Student Bullying Policy)
Minn. Stat. Ch. 363A (Minnesota Human Rights Act)
Minn. Stat. § 609.341 (Definitions)
Minn. Stat. Ch. 260E (Reporting of Maltreatment of Minors)
20 U.S.C. §§ 1681-1688 (Title IX of the Education Amendments of 1972)
29 U.S.C. § 621 *et seq.* (Age Discrimination in Employment Act)
29 U.S.C. § 794 (Section 504 of the Rehabilitation Act of 1973)
42 U.S.C. § 1983 (Civil Action for Deprivation of Rights)
42 U.S.C. § 2000d *et seq.* (Title VI of the Civil Rights Act of 1964)
42 U.S.C. § 2000e *et seq.* (Title VII of the Civil Rights Act)
42 U.S.C. § 12101 *et seq.* (Americans with Disabilities Act)

Cross References: MSBA/MASA Model Policy 102 (Equal Educational Opportunity)
MSBA/MASA Model Policy 401 (Equal Employment Opportunity)
MSBA/MASA Model Policy 402 (Disability Nondiscrimination Policy)
MSBA/MASA Model Policy 403 (Discipline, Suspension, and Dismissal of School District Employees)
MSBA/MASA Model Policy 406 (Public and Private Personnel Data)
MSBA/MASA Model Policy 414 (Mandated Reporting of Child Neglect or Physical or Sexual Abuse)
MSBA/MASA Model Policy 415 (Mandated Reporting of Maltreatment of Vulnerable Adults)
MSBA/MASA Model Policy 506 (Student Discipline)
MSBA/MASA Model Policy 514 (Bullying Prohibition Policy)
MSBA/MASA Model Policy 515 (Protection and Privacy of Pupil Records)
MSBA/MASA Model Policy 521 (Student Disability Nondiscrimination)
MSBA/MASA Model Policy 522 (Title IX Sex Nondiscrimination, Grievance Procedures and Process)
MSBA/MASA Model Policy 524 (Internet Acceptable Use and Safety Policy)
MSBA/MASA Model Policy 525 (Violence Prevention)

MSBA/MASA Model Policy 526 (Hazing Prohibition)
MSBA/MASA Model Policy 528 (Student Parental, Family, and Marital Status
Nondiscrimination)

Replacing: Policy 4015
First Reading: 05-19-2015
Adopted: 06-16-2015
04-19-2016 ISD 709 (*Renumbering only*)
First Reading: 07-19-2016
Second Reading: 08-16-2016
First Reading: 04-15-2025
Second Reading: 05-13-2025
Adopted: 05-20-2025
Revised: 05-19-2026

413 HARASSMENT AND VIOLENCE

I. PURPOSE

The purpose of this policy is to maintain a learning and working environment free from harassment and violence on the basis of race, color, creed, religion, national origin, sex, age, marital status, familial status, status with regard to public assistance, sexual orientation, or disability (Protected Class).

II. GENERAL STATEMENT OF POLICY

- A. The policy of the school district is to maintain a learning and working environment free from harassment and violence on the basis of Protected Class. The school district prohibits any form of harassment or violence on the basis of Protected Class. Harassment and violence of any kind towards any individual is prohibited in Duluth Public Schools.
- B. A violation of this policy occurs when any student, teacher, administrator, or other school district personnel harasses a student, teacher, administrator, or other school district personnel or group of students, teachers, administrators, or other school district personnel through conduct or communication based on a person's Protected Class, as defined by this policy. (For purposes of this policy, school district personnel include school board members, school employees, agents, volunteers, contractors, or persons subject to the supervision and control of the district.)
- C. A violation of this policy occurs when any student, teacher, administrator, or other school district personnel inflicts, threatens to inflict, or attempts to inflict violence upon any student, teacher, administrator, or other school district personnel or group of students, teachers, administrators, or other school district personnel based on a person's Protected Class.
- D. The school district will act to investigate all complaints, either formal or informal, verbal or written, of harassment or violence based on a person's Protected Class, and to discipline or take appropriate action against any student, teacher, administrator, or other school district personnel found to have violated this policy.

III. DEFINITIONS

- A. "Assault" is:
 - 1. an act done with intent to cause fear in another of immediate bodily harm or death;
 - 2. the intentional infliction of or attempt to inflict bodily harm upon another; or
 - 3. the threat to do bodily harm to another with present ability to carry out the threat.
- B. "Harassment" prohibited by this policy consists of physical or verbal conduct, including, but not limited to, electronic communications, relating to an individual's or group of individuals' race, color, creed, religion, national origin, sex, age, marital status, familial status, status with regard to public assistance, sexual orientation, including gender identity or expression, or disability, when the conduct:
 - 1. has the purpose or effect of creating an intimidating, hostile, or offensive working or academic environment;

2. has the purpose or effect of substantially or unreasonably interfering with an individual's work or academic performance; or
 3. otherwise adversely affects an individual's employment or academic opportunities.
- C. "Immediately" means as soon as possible but in no event longer than 24 hours.
- D. Protected Classifications
1. "Disability" means, with respect to an individual who
 - a. has a physical sensory or mental impairment that materially limits one or more major life activities of such individual;
 - b. has a record of such an impairment;
 - c. is regarded as having such an impairment; or
 - d. has an impairment that is episodic or in remission and would materially limit a major life activity when active.
 2. "Familial status" means the condition of one or more minors having legal status or custody with:
 - a. the minor's parent or parents or the minor's legal guardian or guardians; or
 - b. the designee of the parent or parents or guardian or guardians with the written permission of the parent or parents or guardian or guardians. Familial status also means residing with and caring for one or more individuals who lack the ability to meet essential requirements for physical health, safety, or self-care because the individual or individuals are unable to receive and evaluate information or make or communicate decisions. The protections afforded against harassment or discrimination on the basis of family status apply to any person who is pregnant or is in the process of securing legal custody of an individual who has not attained the age of majority.
 3. "Marital status" means whether a person is single, married, remarried, divorced, separated, or a surviving spouse and, in employment cases, includes protection against harassment or discrimination on the basis of the identity, situation, actions, or beliefs of a spouse or former spouse.
 4. "National origin" means the place of birth of an individual or of any of the individual's lineal ancestors.
 5. "Sex" includes, but is not limited to, pregnancy, childbirth, and disabilities related to pregnancy or childbirth.
 6. "Sexual orientation" means to whom someone is, or is perceived of as being, emotionally, physically, or sexually attracted to based on sex or gender identity. A person may be attracted to men, women, both, neither, or to people who are genderqueer, androgynous, or have other gender identities.

7. "Status with regard to public assistance" means the condition of being a recipient of federal, state, or local assistance, including medical assistance, or of being a tenant receiving federal, state, or local subsidies, including rental assistance or rent supplements.
- E. "Remedial response" means a measure to stop and correct acts of harassment or violence, prevent acts of harassment or violence from recurring, and protect, support, and intervene on behalf of a student who is the target or victim of acts of harassment or violence.
- F. Sexual Harassment
1. Sexual harassment includes unwelcome sexual advances, requests for sexual favors, sexually motivated physical conduct, or other verbal or physical conduct or communication of a sexual nature when:
 - a. submission to that conduct or communication is made a term or condition, either explicitly or implicitly, of obtaining employment or an education; or
 - b. submission to or rejection of that conduct or communication by an individual is used as a factor in decisions affecting that individual's employment or education; or
 - c. that conduct or communication has the purpose or effect of substantially interfering with an individual's employment or education, or creating an intimidating, hostile, or offensive employment or educational environment.
 2. Sexual harassment may include, but is not limited to:
 - a. unwelcome verbal harassment or abuse;
 - b. unwelcome pressure for sexual activity;
 - c. unwelcome, sexually motivated, or inappropriate patting, pinching, or physical contact, other than necessary restraint of student(s) by teachers, administrators, or other school district personnel to avoid physical harm to persons or property;
 - d. unwelcome sexual behavior or words, including demands for sexual favors, accompanied by implied or overt threats concerning an individual's employment or educational status;
 - e. unwelcome sexual behavior or words, including demands for sexual favors, accompanied by implied or overt promises of preferential treatment with regard to an individual's employment or educational status; or
 - f. unwelcome behavior or words directed at an individual because of sexual orientation, including gender identity or expression.

G. Sexual Violence

1. Sexual violence is a physical act of aggression or force or the threat thereof that involves the touching of another's intimate parts or forcing a person to touch any person's intimate parts. Intimate parts, as defined in Minnesota Statutes, section 609.341, includes the primary genital area, groin, inner thigh, buttocks, or breast, as well as the clothing covering these areas.
2. Sexual violence may include, but is not limited to:
 - a. touching, patting, grabbing, or pinching another person's intimate parts
 - b. coercing, forcing, or attempting to coerce or force the touching of anyone's intimate parts;
 - c. coercing, forcing, or attempting to coerce or force sexual intercourse or a sexual act on another; or
 - d. threatening to force or coerce sexual acts, including the touching of intimate parts or intercourse, on another.

H. Violence

Violence prohibited by this policy is a physical act of aggression or assault upon another or group of individuals because of, or in a manner reasonably related to an individual's Protected Class.

IV. REPORTING PROCEDURES

- A. Any person who believes he or she has been the target or victim of harassment or violence on the basis of Protected Class by a student, teacher, administrator, or other school district personnel, or any person with knowledge or belief of conduct which may constitute harassment or violence prohibited by this policy toward a student, teacher, administrator, or other school district personnel or group of students, teachers, administrators, or other school district personnel should report the alleged acts immediately to an appropriate school district official designated by this policy. A person may report conduct that may constitute harassment or violence anonymously. If you choose to report anonymously, you will not be informed once an investigation is complete. However, the school district may not rely solely on an anonymous report to determine discipline or other remedial responses.
- B. The school district encourages the reporting party or complainant to use the report form available from the principal or building supervisor of each building or available from the school district office, but oral reports shall be considered complaints as well.
- C. Nothing in this policy shall prevent any person from reporting harassment or violence directly to a school district human rights officer or to the superintendent. If the complaint involves the building report taker, the complaint shall be made or filed directly with the superintendent or the school district human rights officer by the reporting party or complainant.
- D. In Each School Building

The building principal, the principal's designee, or the building supervisor (hereinafter the "building report taker") is the person responsible for receiving oral or written reports of harassment or violence prohibited by this policy at the building level. Any adult school district personnel who receives a report of harassment or violence prohibited by this policy shall inform the building report taker immediately. If the

complaint involves the building report taker, the complaint shall be made or filed directly with the superintendent or the school district human rights officer by the reporting party or complainant. The building report taker shall ensure that this policy and its procedures, practices, consequences, and sanctions are fairly and fully implemented and shall serve as a primary contact on policy and procedural matters.

- E. A teacher, school administrator, volunteer, contractor, or other school employee shall be particularly alert to possible situations, circumstances, or events that might include acts of harassment or violence. Any such person who witnesses, observes, receives a report of, or has other knowledge or belief of conduct that may constitute harassment or violence shall make reasonable efforts to address and resolve the harassment or violence and shall inform the building report taker immediately. School district personnel who fail to inform the building report taker of conduct that may constitute harassment or violence or who fail to make reasonable efforts to address and resolve the harassment or violence in a timely manner may be subject to disciplinary action.
- F. Upon receipt of a report, the building report taker must notify the school district human rights officer immediately, without screening or investigating the report. The building report taker may request, but may not insist upon, a written complaint. A written statement of the facts alleged will be forwarded as soon as practicable by the building report taker to the human rights officer. If the report was given verbally, the building report taker shall personally reduce it to written form within 24 hours and forward it to the human rights officer. Failure to forward any harassment or violence report or complaint as provided herein may result in disciplinary action against the building report taker.
- G. In the District

The school board hereby designates [Steven Johnson, Director of Human Resources, steven.johnson2@isd709.org](mailto:steven.johnson2@isd709.org) ~~Theresa Severance, Executive Director of Human Resources and Operations, theresa.severance@isd709.org~~ as the school district human rights officer(s) to receive reports or complaints of harassment or violence prohibited by this policy. If the complaint involves a human rights officer, the complaint shall be filed directly with the superintendent.
- H. The school district shall conspicuously post the name of the human rights officer(s), including mailing addresses and telephone numbers.
- I. Submission of a good faith complaint or report of harassment or violence prohibited by this policy will not affect the complainant or reporter's future employment, grades, work assignments, or educational or work environment.
- J. Use of formal reporting forms is not mandatory.
- K. Reports of harassment or violence prohibited by this policy are classified as private educational and/or personnel data and/or confidential investigative data and will not be disclosed except as permitted by law.
- L. The school district will respect the privacy of the complainant(s), the individual(s) against whom the complaint is filed, and the witnesses as much as possible, consistent with the school district's legal obligations to investigate, to take appropriate action, and to comply with any discovery or disclosure obligations.
- M. Retaliation against a victim, good faith reporter, or a witness of violence or harassment is prohibited.
- N. False accusations or reports of violence or harassment against another person are prohibited.

- O. A person who engages in an act of violence or harassment, reprisal, retaliation, or false reporting of violence or harassment, or permits, condones, or tolerates violence or harassment shall be subject to discipline or other remedial responses for that act in accordance with the school district's policies and procedures.

Consequences for students who commit, or are a party to, prohibited acts of violence or harassment or who engage in reprisal or intentional false reporting may range from remedial responses or positive behavioral interventions up to and including suspension and/or expulsion.

Consequences for employees who permit, condone, or tolerate violence or harassment or engage in an act of reprisal or intentional false reporting of violence or harassment may result in disciplinary action up to and including termination or discharge.

Consequences for other individuals engaging in prohibited acts of violence or harassment may include, but not be limited to, exclusion from school district property and events and/or termination of services and/or contracts.

V. INVESTIGATION

- A. By authority of the school district, the human rights officer, within three (3) days of the receipt of a report or complaint alleging harassment or violence prohibited by this policy, shall undertake or authorize an investigation. The investigation may be conducted by school district officials or by a third party designated by the school district.
- B. The investigation may consist of personal interviews with the complainant, the individual(s) against whom the complaint is filed, and others who may have knowledge of the alleged incident(s) or circumstances giving rise to the complaint. The investigation may also consist of any other methods and documents deemed pertinent by the investigator.
- C. In determining whether alleged conduct constitutes a violation of this policy, the school district should consider the surrounding circumstances, the nature of the behavior, past incidents or past or continuing patterns of behavior, the relationships between the parties involved, and the context in which the alleged incidents occurred. Whether a particular action or incident constitutes a violation of this policy requires a determination based on all the facts and surrounding circumstances.
- D. In addition, the school district may take immediate steps, at its discretion, to protect the target or victim, the complainant, and students, teachers, administrators, or other school district personnel pending completion of an investigation of alleged harassment or violence prohibited by this policy.
- E. The alleged perpetrator of the act(s) of harassment or violence shall be allowed the opportunity to present a defense during the investigation or prior to the imposition of discipline or other remedial responses.
- F. The investigation will be completed as soon as practicable. The school district human rights officer shall make a written report to the superintendent upon completion of the investigation. If the complaint involves the superintendent, the report may be filed directly with the school board. The report shall include a determination of whether the allegations have been substantiated as factual and whether they appear to be violations of this policy.

VI. SCHOOL DISTRICT ACTION

- A. Upon completion of an investigation that determines a violation of this policy has occurred, the school district will take appropriate action. Such action may include, but is not limited to, warning, suspension, exclusion, expulsion, transfer, remediation, termination, or discharge. Disciplinary consequences will be sufficiently severe to try to deter violations and to appropriately discipline prohibited behavior. School district action taken for violation of this policy will be consistent with requirements of applicable collective bargaining agreements, Minnesota and federal law, and applicable school district policies and regulations.
- B. The school district is not authorized to disclose to a victim private educational or personnel data regarding an alleged perpetrator who is a student or employee of the school district. School officials will notify the targets or victims and alleged perpetrators of harassment or violence, the parent(s) or guardian(s) of targets or victims of harassment or violence and the parent(s) or guardian(s) of alleged perpetrators of harassment or violence who have been involved in a reported and confirmed harassment or violence incident of the remedial or disciplinary action taken, to the extent permitted by law.
- C. In order to prevent or respond to acts of harassment or violence committed by or directed against a child with a disability, the school district shall, where determined appropriate by the child's individualized education program (IEP) or Section 504 team, allow the child's IEP or Section 504 plan to be drafted to address the skills and proficiencies the child needs as a result of the child's disability to allow the child to respond to or not to engage in acts of harassment or violence.

VII. RETALIATION OR REPRISAL

The school district will discipline or take appropriate action against any student, teacher, administrator, or other school district personnel who commits an act of reprisal or who retaliates against any person who asserts, alleges, or makes a good faith report of alleged harassment or violence prohibited by this policy, who testifies, assists, or participates in an investigation of retaliation or alleged harassment or violence, or who testifies, assists, or participates in a proceeding or hearing relating to such harassment or violence. Retaliation includes, but is not limited to, any form of intimidation, reprisal, harassment, or intentional disparate treatment. Disciplinary consequences will be sufficiently severe to deter violations and to appropriately discipline the individual(s) who engaged in the harassment or violence. Remedial responses to the harassment or violence shall be tailored to the particular incident and nature of the conduct.

VIII. RIGHT TO ALTERNATIVE COMPLAINT PROCEDURES

These procedures do not deny the right of any individual to pursue other avenues of recourse which may include filing charges with the Minnesota Department of Human Rights or another state or federal agency, initiating civil action, or seeking redress under state criminal statutes and/or federal law.

IX. HARASSMENT OR VIOLENCE AS ABUSE

- A. Under certain circumstances, alleged harassment or violence may also be possible abuse under Minnesota law. If so, the duties of mandatory reporting under Minnesota Statutes, chapter 260E may be applicable.
- B. Nothing in this policy will prohibit the school district from taking immediate action to protect victims of alleged harassment, violence, or abuse.

X. DISSEMINATION OF POLICY AND TRAINING

- A. This policy shall be conspicuously posted throughout each school building in areas accessible to students and staff members.
- B. This policy shall be given to each school district employee and independent contractor who regularly interacts with students at the time of initial employment with the school district.
- C. This policy shall appear in the student handbook.
- D. The school district will develop a method of discussing this policy with students and employees.
- E. The school district may implement violence prevention and character development education programs to prevent and reduce policy violations. Such programs may offer instruction on character education including, but not limited to, character qualities such as attentiveness, truthfulness, respect for authority, diligence, gratefulness, self-discipline, patience, forgiveness, respect for others, peacemaking, resourcefulness, and/or sexual abuse prevention.
- F. This policy shall be reviewed at least annually for compliance with state and federal law.

Legal References: Minn. Stat. § 120B.232 (Character Development Education)
Minn. Stat. § 120B.234 (Child Sexual Abuse Prevention Education)
Minn. Stat. § 121A.03, Subd. 2 (Sexual, Religious, and Racial Harassment and Violence Policy)
Minn. Stat. § 121A.031 (School Student Bullying Policy)
Minn. Stat. Ch. 363A (Minnesota Human Rights Act)
Minn. Stat. § 609.341 (Definitions)
Minn. Stat. Ch. 260E (Reporting of Maltreatment of Minors)
20 U.S.C. §§ 1681-1688 (Title IX of the Education Amendments of 1972)
29 U.S.C. § 621 *et seq.* (Age Discrimination in Employment Act)
29 U.S.C. § 794 (Section 504 of the Rehabilitation Act of 1973)
42 U.S.C. § 1983 (Civil Action for Deprivation of Rights)
42 U.S.C. § 2000d *et seq.* (Title VI of the Civil Rights Act of 1964)
42 U.S.C. § 2000e *et seq.* (Title VII of the Civil Rights Act)
42 U.S.C. § 12101 *et seq.* (Americans with Disabilities Act)

Cross References: MSBA/MASA Model Policy 102 (Equal Educational Opportunity)
MSBA/MASA Model Policy 401 (Equal Employment Opportunity)
MSBA/MASA Model Policy 402 (Disability Nondiscrimination Policy)
MSBA/MASA Model Policy 403 (Discipline, Suspension, and Dismissal of School District Employees)
MSBA/MASA Model Policy 406 (Public and Private Personnel Data)
MSBA/MASA Model Policy 414 (Mandated Reporting of Child Neglect or Physical or Sexual Abuse)
MSBA/MASA Model Policy 415 (Mandated Reporting of Maltreatment of Vulnerable Adults)
MSBA/MASA Model Policy 506 (Student Discipline)
MSBA/MASA Model Policy 514 (Bullying Prohibition Policy)
MSBA/MASA Model Policy 515 (Protection and Privacy of Pupil Records)
MSBA/MASA Model Policy 521 (Student Disability Nondiscrimination)
MSBA/MASA Model Policy 522 (Title IX Sex Nondiscrimination, Grievance Procedures and Process)
MSBA/MASA Model Policy 524 (Internet Acceptable Use and Safety Policy)

MSBA/MASA Model Policy 525 (Violence Prevention)
MSBA/MASA Model Policy 526 (Hazing Prohibition)
MSBA/MASA Model Policy 528 (Student Parental, Family, and Marital Status
Nondiscrimination)

Replacing: Policy 4015
First Reading: 05-19-2015
Adopted: 06-16-2015
04-19-2016 ISD 709 (*Renumbering only*)
First Reading: 07-19-2016
Second Reading: 08-16-2016
First Reading: 04-15-2025
Second Reading: 05-13-2025
Adopted: 05-20-2025
Revised:

511 FUNDRAISING

I. PURPOSE

The purpose of this policy is to address fundraising efforts by students and employees of the Duluth Public Schools.

II. GENERAL STATEMENT OF POLICY

The school board recognizes a desire and a need by some student organizations for fundraising. The school board also recognizes a need for some constraint to prevent fundraising activities from becoming too numerous and overly demanding on employees, students, and the general public. All fundraising activities must be approved by both administration and the School Board before they begin.

III. DEFINITION

- A. Fundraising examples include, but are not limited to, grocery bagging for tips, gift and discount card sales, book fairs, food sales, plant sales, Box Tops for Education, and crowdfunding activities. Any activity for the purpose of raising funds for a club, team, or school is considered a fundraiser.

III. RESPONSIBILITY

- A. The building administrators shall be responsible for developing recommendations to the superintendent that will result in a level of activity deemed acceptable by employees, parents, and students. Fundraising must be conducted in a manner that will not result in embarrassment on the part of individual students, employees, or the school.
- B. All fundraising activities must be approved, in advance, by both the administration and school board. Participation in nonapproved activities shall be considered a violation of school district policy.
- C. The superintendent shall be responsible for providing coordination of student fundraising throughout the school district as deemed appropriate.
- D. The school district expects all students who participate in approved fundraising activities to represent the school, the student organization, and the community in a responsible manner. All rules pertaining to student conduct and student discipline extend to student fundraising activities.
- E. The school district expects all employees who plan, supervise, coordinate, or participate in student fundraising activities to act in the best interests of the students and to represent the school, the student organization, and the community in a responsible manner.
- F. The building administrators shall be responsible for complying with the District's Wellness Policy (Policy 533).

- G. When a fundraising event is taking place at a district site, the Facility Use Coordinator must be contacted.

IV. MONTHLY REPORT

All fundraisers shall be reported to the school board on a monthly basis and will describe the nature and scope of student fundraising activities approved pursuant to this policy.

Legal References: Minn. Stat. § 120A.20 (Admission to Public School)
Minn. Stat. § 123B.09, Subd. 8 (Boards of Independent School Districts)
Minn. Stat. § 123B.36 (Authorized Fees)

Cross References: MSBA/MASA Model Policy 506 (Student Discipline)
MSBA/MASA Model Policy 713 (Student Activity Accounting)

Other References: 2019 UFARS Chapter 14 Student Activity Accounting

New Policy
Replacing: 1050
First Reading: 11-19-2019
Adopted: 12-17-2019
Revised: 05-19-2026

511 FUNDRAISING

I. PURPOSE

The purpose of this policy is to address fundraising efforts by students and employees of the Duluth Public Schools.

II. GENERAL STATEMENT OF POLICY

The school board recognizes a desire and a need by some student organizations for fundraising. The school board also recognizes a need for some constraint to prevent fundraising activities from becoming too numerous and overly demanding on employees, students, and the general public. All fundraising activities must be approved by both administration and the School Board before they begin.

III. DEFINITION

A. Fundraising examples include, but are not limited to, grocery bagging for tips, gift and discount card sales, book fairs, food sales, plant sales, Box Tops for Education, and crowdfunding activities. Any activity for the purpose of raising funds for a club, team, or school is considered a fundraiser.

III. RESPONSIBILITY

- A. The building administrators shall be responsible for developing recommendations to the superintendent that will result in a level of activity deemed acceptable by employees, parents, and students. Fundraising must be conducted in a manner that will not result in embarrassment on the part of individual students, employees, or the school.
- B. All fundraising activities must be approved, in advance, by both the administration and school board. Participation in nonapproved activities shall be considered a violation of school district policy.
- C. The superintendent shall be responsible for providing coordination of student fundraising throughout the school district as deemed appropriate.
- D. The school district expects all students who participate in approved fundraising activities to represent the school, the student organization, and the community in a responsible manner. All rules pertaining to student conduct and student discipline extend to student fundraising activities.
- E. The school district expects all employees who plan, supervise, coordinate, or participate in student fundraising activities to act in the best interests of the students and to represent the school, the student organization, and the community in a responsible manner.
- F. The building administrators shall be responsible for complying with the District's Wellness Policy (Policy 533).

- G. When a fundraising event is taking place at a district site, the Facility Use Coordinator must be contacted.

IV. MONTHLY ANNUAL REPORT

All fundraisers The superintendent shall be reported to the school board, at least annually, on a monthly basis and will describe the nature and scope of student fundraising activities approved pursuant to this policy.

Legal References: Minn. Stat. § 120A.20 (~~Age Limitations; Pupils Admission to Public School~~)
Minn. Stat. § 123B.09, Subd. 8 (~~Duties Boards of Independent School Districts~~)
Minn. Stat. § 123B.36 (Authorized Fees)

Cross References: MSBA/MASA Model Policy 506 (Student Discipline)
MSBA/MASA Model Policy 713 (Student Activity Accounting)

Other References: 2019 UFARS Chapter 14 Student Activity Accounting

New Policy
Replacing: 1050
First Reading: 11-19-2019
Adopted: 12-17-2019
Revised:

606 TEXTBOOKS AND INSTRUCTIONAL MATERIALS

I. PURPOSE

The purpose of this policy is to provide direction for selection of textbooks and instructional materials.

II. GENERAL STATEMENT OF POLICY

The school board recognizes that selection of textbooks and instructional materials is a vital component of the school district's curriculum. The school board also recognizes that it has the authority to make final decisions on selection of all textbooks and instructional materials.

III. RESPONSIBILITY OF SELECTION

- A. While the school board retains its authority to make final decisions on the selection of textbooks and instructional materials, the school board recognizes the expertise of the professional staff and the vital need of such staff to be primarily involved in the recommendation of textbooks and instructional materials. Accordingly, the school board delegates to the superintendent the responsibility to direct the professional staff in formulating recommendations to the school board on textbooks and other instructional materials.
- B. In reviewing textbooks and instructional materials during the selection process, the professional staff shall select materials that:
 - 1. support the goals and objectives of the education programs;
 - 2. consider the needs, age, and maturity of students;
 - 3. foster respect and appreciation for cultural diversity and varied opinion;
 - 4. fit within the constraints of the school district budget;
 - 5. are in the English language. Another language may be used, pursuant to Minnesota Statutes, 124D.59 to 124D.61;
 - 6. permit grade-level instruction for students to read and study America's founding documents, including documents that contributed to the foundation or maintenance of America's representative form of limited government, the Bill of Rights, our free-market economic system, and patriotism; and
 - 7. do not censor or restrain instruction in American or Minnesota state history or heritage based on religious references in original source documents, writings, speeches, proclamations, or records.
- C. The superintendent shall be responsible for developing procedures and guidelines to establish an orderly process for the review and recommendation of textbooks and other instructional materials by the professional staff. Such procedures and guidelines shall provide opportunity for input and consideration of the views of students, parents, and other interested members of the school district community. This procedure shall be coordinated with the school district's curriculum development effort and may utilize advisory committees.

IV. SELECTION OF TEXTBOOKS AND OTHER INSTRUCTIONAL MATERIALS

- A. The superintendent shall be responsible for keeping the school board informed of progress on the part of staff and others involved in the textbook and other instructional materials review and selection process.
- B. The superintendent shall present a recommendation to the school board on the selection of textbooks and other instructional materials after completion of the review process as outlined in this policy.

V. RECONSIDERATION OF TEXTBOOKS OR OTHER INSTRUCTIONAL MATERIALS

- A. The school board recognizes differences of opinion on the part of some members of the school district community relating to certain areas of the instruction program. Interested persons may request an opportunity to review materials and submit a request for reconsideration of the use of certain textbooks or instructional materials. Access to the materials in question shall not be restricted until the procedures listed below have been fully completed and a decision to remove or restrict the materials has been made.

B. Formal Request for Reconsideration of a Textbook or Other Instructional Resource

- 1. A Formal Request for Reconsideration of a textbook or other instructional resource is initiated upon submission of a completed [Formal Request for Reconsideration of Instructional Resource or Specific Library Collection Material](#) form. The form must be completed in its entirety for each resource that is subject to a request for reconsideration and submitted to the school principal. The principal shall notify the superintendent or the superintendent's designee of receipt of a completed Formal Request form.

The district will respond to Formal Request for Reconsideration within 60 school contract days. One challenge will be addressed by the committee at a time.

If specific instructional material is the subject of a Formal Request for Reconsideration and a final decision is made to retain the specific instructional material, then the specific instructional material shall not be subject to additional requests for reconsideration for three years following the date of final resolution of the initial Formal Request for Reconsideration.

- 2. The Superintendent or the superintendent's designee shall appoint an Instructional Materials Review Committee (Review Committee) upon receipt of a Formal Request for Reconsideration. This committee shall include:
 - a. One member of the school district administration
 - b. One principal
 - c. Two teachers of the discipline named in the complaint (one of which shall be the content area lead teacher)
 - d. Two members of the school district community with no direct connection with the request for reconsideration
 - e. Two student representatives (as appropriate to the specific request).
- 3. The Review Committee chair shall establish a date upon which it will discuss

the request and whether the specific instructional material conforms to the selection criteria set forth in this policy.

4. The Review Committee
 - a. may consult individuals, organizations, and other resources with relevant professional knowledge on instructional material;
 - b. shall examine the specific instructional material's area of concern;
 - c. shall examine the specific instructional material as to its conformance with the criteria for selection of instructional materials; and
 - d. shall submit a written report to the superintendent or the superintendent's designee containing the Review Committee's decision on whether to retain, to remove, or to take other action regarding the specific instructional material.
 5. The superintendent or the superintendent's designee shall inform the requestor and the school board of the Review Committee's decision.
 6. The requestor shall have the right to appeal the decision of the Review Committee to the superintendent and the school board.
- C. All instructional materials, including teacher's manuals, films, tapes, or other supplementary material which will be used in connection with any survey, analysis, or evaluation as part of any applicable program shall be available for inspection by the parents or guardians of the students.

Legal References: Minn. Stat. § 120A.22, Subd. 9 (Compulsory Instruction)
Minn. Stat. § 120B.235 (American Heritage Education)
Minn. Stat. § 123B.02, Subd. 2 (General Powers of Independent School Districts)
Minn. Stat. § 123B.09, Subd. 8 (School Board Responsibilities)
Minn. Stat. § 124D.59-124D.61 (Education for English Learners Act)
Minn. Stat. § 127A.10 (State Officials and School Board Members to be Disinterested; Penalty)
20 U.S.C. 1232h(a) (Protection of Pupil Rights)
Hazelwood Sch. Dist. v. Kuhlmeier, 484 U.S. 260 (1988)
Pratt v. Independent Sch. Dist. No. 831, 670 F.2d 771 (8th Cir. 1982)

Cross References: MSBA/MASA Model Policy 603 (Curriculum Development)
MSBA/MASA Model Policy 604 (Instructional Curriculum)

Replaces: Policies 6030, 6035 & 6040
First Reading: 12.19.2023
Second Reading: 01.23.2024
Adopted: 01.23.2024
Reviewed: 01.28.2025
Revised: 05.19.2026

606 TEXTBOOKS AND INSTRUCTIONAL MATERIALS

I. PURPOSE

The purpose of this policy is to provide direction for selection of textbooks and instructional materials.

II. GENERAL STATEMENT OF POLICY

The school board recognizes that selection of textbooks and instructional materials is a vital component of the school district's curriculum. The school board also recognizes that it has the authority to make final decisions on selection of all textbooks and instructional materials.

III. RESPONSIBILITY OF SELECTION

- A. While the school board retains its authority to make final decisions on the selection of textbooks and instructional materials, the school board recognizes the expertise of the professional staff and the vital need of such staff to be primarily involved in the recommendation of textbooks and instructional materials. Accordingly, the school board delegates to the superintendent the responsibility to direct the professional staff in formulating recommendations to the school board on textbooks and other instructional materials.
- B. In reviewing textbooks and instructional materials during the selection process, the professional staff shall select materials that:
 - 1. support the goals and objectives of the education programs;
 - 2. consider the needs, age, and maturity of students;
 - 3. foster respect and appreciation for cultural diversity and varied opinion;
 - 4. fit within the constraints of the school district budget;
 - 5. are in the English language. Another language may be used, pursuant to Minnesota Statutes, 124D.59 to 124D.61;
 - 6. permit grade-level instruction for students to read and study America's founding documents, including documents that contributed to the foundation or maintenance of America's representative form of limited government, the Bill of Rights, our free-market economic system, and patriotism; and
 - 7. do not censor or restrain instruction in American or Minnesota state history or heritage based on religious references in original source documents, writings, speeches, proclamations, or records.
- C. The superintendent shall be responsible for developing procedures and guidelines to establish an orderly process for the review and recommendation of textbooks and other instructional materials by the professional staff. Such procedures and guidelines shall provide opportunity for input and consideration of the views of students, parents, and other interested members of the school district community. This procedure shall be coordinated with the school district's curriculum development effort and may utilize advisory committees.

IV. SELECTION OF TEXTBOOKS AND OTHER INSTRUCTIONAL MATERIALS

- A. The superintendent shall be responsible for keeping the school board informed of progress on the part of staff and others involved in the textbook and other instructional materials review and selection process.
- B. The superintendent shall present a recommendation to the school board on the selection of textbooks and other instructional materials after completion of the review process as outlined in this policy.

V. RECONSIDERATION OF TEXTBOOKS OR OTHER INSTRUCTIONAL MATERIALS

- A. The school board recognizes differences of opinion on the part of some members of the school district community relating to certain areas of the instruction program. Interested persons may request an opportunity to review materials and submit a request for reconsideration of the use of certain textbooks or instructional materials. Access to the materials in question shall not be restricted until the procedures listed below have been fully completed and a decision to remove or restrict the materials has been made.

B. Formal Request for Reconsideration of a Textbook or Other Instructional Resource

- 1. A Formal Request for Reconsideration of a textbook or other instructional resource is initiated upon submission of a completed [Formal Request for Reconsideration of Instructional Resource or Specific Library Collection Material](#) form. The form must be completed in its entirety for each resource that is subject to a request for reconsideration and submitted to the school principal. The principal shall notify the superintendent or the superintendent's designee of receipt of a completed Formal Request form.

The district will respond to Formal Request for Reconsideration within 60 school contract days. One challenge will be addressed by the committee at a time.

If specific instructional material is the subject of a Formal Request for Reconsideration and a final decision is made to retain the specific instructional material, then the specific instructional material shall not be subject to additional requests for reconsideration for three years following the date of final resolution of the initial Formal Request for Reconsideration.

- 2. The Superintendent or the superintendent's designee shall appoint an Instructional Materials Review Committee (Review Committee) upon receipt of a Formal Request for Reconsideration. This committee shall include:
 - a. One member of the school district administration
 - b. One principal
 - c. Two teachers of the discipline named in the complaint (one of which shall be the content area lead teacher)
 - d. Two members of the school district community with no direct connection with the request for reconsideration
 - e. Two student representatives (as appropriate to the specific request).
- 3. The Review Committee chair shall establish a date upon which it will discuss

the request and whether the specific instructional material conforms to the selection criteria set forth in this policy.

4. The Review Committee

- a. may consult individuals, organizations, and other resources with relevant professional knowledge on instructional material;
- b. shall examine the specific instructional material's area of concern;
- c. shall examine the specific instructional material as to its conformance with the criteria for selection of instructional materials; and
- d. shall submit a written report to the superintendent or the superintendent's designee containing the Review Committee's decision on whether to retain, to remove, or to take other action regarding the specific instructional material.

5. The superintendent or the superintendent's designee shall inform the requestor and the school board of the Review Committee's decision.

6. The requestor shall have the right to appeal the decision of the Review Committee to the superintendent and the school board.

- C. All instructional materials, including teacher's manuals, films, tapes, or other supplementary material which will be used in connection with any survey, analysis, or evaluation as part of any applicable program shall be available for inspection by the parents or guardians of the students.

Legal References: Minn. Stat. § 120A.22, Subd. 9 (Compulsory Instruction ~~—Knowledge and Skills~~)
Minn. Stat. § 120B.235 (American Heritage Education)
Minn. Stat. § 123B.02, Subd. 2 (General Powers of Independent School Districts)
Minn. Stat. § 123B.09, Subd. 8 (School Board Responsibilities)
Minn. Stat. § 124D.59-124D.61 (Education for English Learners Act)
Minn. Stat. § 127A.10 (State Officials and School Board Members to be Disinterested; Penalty)
20 U.S.C. 1232h(a) (Protection of Pupil Rights)
Hazelwood Sch. Dist. v. Kuhlmeier, 484 U.S. 260 (1988)
Pratt v. Independent Sch. Dist. No. 831, 670 F.2d 771 (8th Cir. 1982)

Cross References: MSBA/MASA Model Policy 603 (Curriculum Development)
MSBA/MASA Model Policy 604 (Instructional Curriculum)

Replaces: Policies 6030, 6035 & 6040
First Reading: 12.19.2023
Second Reading: 01.23.2024
Adopted: 01.23.2024
Reviewed: 01.28.2025
Revised:

701 ESTABLISHMENT AND ADOPTION OF SCHOOL DISTRICT BUDGET

I. PURPOSE

The purpose of this policy is to establish lines of authority and procedures for the establishment of the school district's revenue and expenditure budgets.

II. GENERAL STATEMENT OF POLICY

The policy of the school district is to establish its revenue and expenditure budgets in accordance with the applicable provisions of law. Budget planning is an integral part of program planning so that the annual budget will effectively express and implement school board goals, and the mission, values and priorities of the school district.

III. REQUIREMENTS

- A. The superintendent or such other school official as designated by the superintendent or the school board, shall each year prepare preliminary revenue and expenditure budgets for review in April, by the school board or its designated committee or committees. When projected expenditures exceed projected revenues, the school board may consider use of an available fund balance, if one exists.
- B. Expenditures shall be reported in compliance with Minnesota Statutes section 123B.76.
- C. Prior to July 1 of each year, the school board must approve and adopt its revenue and expenditure budgets for the next school year. The budget document so adopted must be considered an expenditure authorizing or appropriations document. No funds shall be expended for any purpose in any school year prior to the adoption of the budget document which authorizes that expenditure for that year, or prior to the adoption of an amendment to that budget document by the school board to authorize that expenditure for that year.
- D. Each year, the school district must publish its adopted revenue and expenditure budgets for the current year, the actual revenues, expenditures, and fund balances for the prior year, and the projected fund balances for the current year in the form prescribed by the Commissioner of the Minnesota Department of Education (Commissioner) within one week of the acceptance of the final audit by the school board, or November 30, whichever is earlier. A statement must be included in the publication that the complete budget in detail may be inspected by any resident of the school district upon request to the superintendent. At the same time as this publication, the school district shall publish the other information required by Minnesota Statutes-, § section 123B.10.
- E. At the public hearing on the adoption of the school district's proposed property tax levy, the school board shall review its current budget and the proposed property taxes payable in the following calendar year.
- F. The school district must also post the materials specified in Paragraph III.D. above in a conspicuous place on the school district's official website, including a link to the school district's school report card on the Minnesota Department of Education's website.

IV. IMPLEMENTATION

- A. The school board places the responsibility for administering the adopted budget with the superintendent. The superintendent may delegate duties related thereto to other school officials, but maintains the ultimate responsibility for this function.
- B. The program-oriented budgeting system will be supported by a program-oriented accounting structure organized and operated on a fund basis as provided for in Minnesota statutes through the Uniform Financial Accounting and Reporting Standards for Minnesota School Districts (UFARS).
- C. The superintendent or the superintendent’s designee is authorized to make payments of claims or salaries authorized by the adopted or amended budget prior to school board approval.
- D. Supplies and capital equipment can be ordered prior to budget adoption only by authority of the school board. If additional personnel are provided in the proposed budget, actual hiring may not occur until the budget is adopted unless otherwise approved by the school board. Other funds to be expended in a subsequent school year may not be encumbered prior to budget adoption unless specifically approved by the school board.
- E. The school district shall make such reports to the Commissioner as required relating to initial allocations of revenue, reallocations of revenue, and expenditures of funds.

Legal References: Minn. Stat. § 123B.10 (Publication of Financial Information)
Minn. Stat. § 123B.76 (Expenditures; Reporting)
Minn. Stat. § 123B.77 (Accounting, Budgeting, and Reporting Requirements)

Cross References: MSBA/MASA Model Policy 701.1 (Modification of School District Budget)
MSBA/MASA Model Policy 702 (Accounting)

New Policy
Replacing: 3005, 3015, 3100, 3105, 3110
First Reading: 08-21-2018
Adopted: 09-18-2018
Revised: 05-19-2026

701 ESTABLISHMENT AND ADOPTION OF SCHOOL DISTRICT BUDGET

I. PURPOSE

The purpose of this policy is to establish lines of authority and procedures for the establishment of the school district's revenue and expenditure budgets.

II. GENERAL STATEMENT OF POLICY

The policy of the school district is to establish its revenue and expenditure budgets in accordance with the applicable provisions of law. Budget planning is an integral part of program planning so that the annual budget will effectively express and implement school board goals, **and the mission, values** and priorities of the school district.

III. REQUIREMENTS

- A. The superintendent or such other school official as designated by the superintendent or the school board, shall each year prepare preliminary revenue and expenditure budgets for review **in April**, by the school board or its designated committee or committees. ~~The preliminary budgets shall be accompanied by such written commentary as may be necessary for them to be clearly understood by the members of the school board and the public. The school board shall review the projected revenues and expenditures for the school district for the next fiscal year, and make such adjustments in the expenditure budget as necessary to carry out the education program within the revenues projected.~~ When projected expenditures exceed projected revenues, the school board may consider use of an available fund balance, if one exists.
- B. ~~The school district must maintain separate accounts to identify revenues and expenditures for each building.~~ Expenditures shall be reported in compliance with Minnesota Statutes, § section 123B.76.
- C. Prior to July 1 of each year, the school board **shall must** approve and adopt its **initial** revenue and expenditure budgets for the next school year. The ~~adopted expenditure budget document so adopted must shall~~ be considered ~~the school board's an expenditure authorizing or appropriations document authorization for that school year.~~ No funds ~~may shall~~ be expended for any purpose in any school year prior to the adoption of the budget document which authorizes that expenditure for that year, or prior to the adoption of an amendment to that budget document by the school board to authorize that expenditure for that year.
- D. Each year, the school district **shall must** publish its adopted revenue and expenditure budgets for the current year, the actual revenues, expenditures, and fund balances for the prior year, and the projected fund balances for the current year in the form prescribed by the Commissioner of the Minnesota Department of Education (Commissioner) within one week of the acceptance of the final audit by the school board, or November 30, whichever is earlier. A statement **shall must** be included in the publication that the complete budget in detail may be inspected by any resident of the school district upon request to the superintendent. ~~A summary of this information and the address of the school district's official website where the information can be found must be published in a newspaper of general circulation in the school district.~~ At the same time as this publication, the school district shall publish the other information required by Minnesota Statutes, § section 123B.10.

- E. At the public hearing on the adoption of the school district's proposed property tax levy, the school board shall review its current budget and the proposed property taxes payable in the following calendar year.
- F. The school district must also post the materials specified in Paragraph III.D. above **in a conspicuous place** on the school district's official website, including a link to the school district's school report card on the Minnesota Department of Education's website. ~~and publish a summary of information and the address of the school district's website where the information can be found in a qualified newspaper of general circulation in the district.~~

IV. IMPLEMENTATION

- A. The school board places the responsibility for administering the adopted budget with the superintendent. The superintendent may delegate duties related thereto to other school officials, but maintains the ultimate responsibility for this function.
- B. The program-oriented budgeting system will be supported by a program-oriented accounting structure organized and operated on a fund basis as provided for in Minnesota statutes through the Uniform Financial Accounting and Reporting Standards for Minnesota School Districts (UFARS).
- C. The superintendent or the superintendent's designee is authorized to make payments of claims or salaries authorized by the adopted or amended budget prior to school board approval.
- D. Supplies and capital equipment can be ordered prior to budget adoption only by authority of the school board. If additional personnel are provided in the proposed budget, actual hiring may not occur until the budget is adopted unless otherwise approved by the school board. Other funds to be expended in a subsequent school year may not be encumbered prior to budget adoption unless specifically approved by the school board.
- E. The school district shall make such reports to the Commissioner as required relating to initial allocations of revenue, reallocations of revenue, and expenditures of funds.

Legal References: Minn. Stat. § 123B.10 (Publication of Financial Information)
Minn. Stat. § 123B.76 (Expenditures; Reporting)
Minn. Stat. § 123B.77 (Accounting, Budgeting, and Reporting Requirements)

Cross References: MSBA/MASA Model Policy 701.1 (Modification of School District Budget)
MSBA/MASA Model Policy 702 (Accounting)
~~MSBA Service Manual, Chapter 7, Education Funding~~

New Policy
Replacing: 3005, 3015, 3100, 3105, 3110
First Reading: 08-21-2018
Adopted: 09-18-2018
Revised:

701 ESTABLISHMENT AND ADOPTION OF SCHOOL DISTRICT BUDGET

I. PURPOSE

The purpose of this policy is to establish lines of authority and procedures for the establishment of the school district's revenue and expenditure budgets.

II. GENERAL STATEMENT OF POLICY

The policy of the school district is to establish its revenue and expenditure budgets in accordance with the applicable provisions of law. Budget planning is an integral part of program planning so that the annual budget will effectively express and implement school board goals, and the mission, values and priorities of the school district.

III. REQUIREMENTS

- A. The superintendent or such other school official as designated by the superintendent or the school board, shall each year prepare preliminary revenue and expenditure budgets for review in April, by the school board or its designated committee or committees. When projected expenditures exceed projected revenues, the school board may consider use of an available fund balance, if one exists.
- B. Expenditures shall be reported in compliance with Minnesota Statutes section 123B.76.
- C. Prior to July 1 of each year, the school board must approve and adopt its revenue and expenditure budgets for the next school year. The budget document so adopted must be considered an expenditure authorizing or appropriations document. No funds shall be expended for any purpose in any school year prior to the adoption of the budget document which authorizes that expenditure for that year, or prior to the adoption of an amendment to that budget document by the school board to authorize that expenditure for that year.
- D. Each year, the school district must publish its adopted revenue and expenditure budgets for the current year, the actual revenues, expenditures, and fund balances for the prior year, and the projected fund balances for the current year in the form prescribed by the Commissioner of the Minnesota Department of Education (Commissioner) within one week of the acceptance of the final audit by the school board, or November 30, whichever is earlier. A statement must be included in the publication that the complete budget in detail may be inspected by any resident of the school district upon request to the superintendent. At the same time as this publication, the school district shall publish the other information required by Minnesota Statutes-, § section 123B.10.
- E. At the public hearing on the adoption of the school district's proposed property tax levy, the school board shall review its current budget and the proposed property taxes payable in the following calendar year.
- F. The school district must also post the materials specified in Paragraph III.D. above in a conspicuous place on the school district's official website, including a link to the school district's school report card on the Minnesota Department of Education's website.

IV. IMPLEMENTATION

- A. The school board places the responsibility for administering the adopted budget with the superintendent. The superintendent may delegate duties related thereto to other school officials, but maintains the ultimate responsibility for this function.
- B. The program-oriented budgeting system will be supported by a program-oriented accounting structure organized and operated on a fund basis as provided for in Minnesota statutes through the Uniform Financial Accounting and Reporting Standards for Minnesota School Districts (UFARS).
- C. The superintendent or the superintendent’s designee is authorized to make payments of claims or salaries authorized by the adopted or amended budget prior to school board approval.
- D. Supplies and capital equipment can be ordered prior to budget adoption only by authority of the school board. If additional personnel are provided in the proposed budget, actual hiring may not occur until the budget is adopted unless otherwise approved by the school board. Other funds to be expended in a subsequent school year may not be encumbered prior to budget adoption unless specifically approved by the school board.
- E. The school district shall make such reports to the Commissioner as required relating to initial allocations of revenue, reallocations of revenue, and expenditures of funds.

Legal References: Minn. Stat. § 123B.10 (Publication of Financial Information)
Minn. Stat. § 123B.76 (Expenditures; Reporting)
Minn. Stat. § 123B.77 (Accounting, Budgeting, and Reporting Requirements)

Cross References: MSBA/MASA Model Policy 701.1 (Modification of School District Budget)
MSBA/MASA Model Policy 702 (Accounting)

New Policy
Replacing: 3005, 3015, 3100, 3105, 3110
First Reading: 08-21-2018
Adopted: 09-18-2018
Revised: 05-19-2026

701.1 MODIFICATION OF SCHOOL DISTRICT BUDGET

I. PURPOSE

The purpose of this policy is to establish procedures for the modification of the school district's adopted revenue and expenditure budgets.

II. GENERAL STATEMENT OF POLICY

The policy of this school district is to modify its revenue and expenditure budgets in accordance with the applicable provisions of law.

III. REQUIREMENT

- A. The school district's adopted expenditure budget shall be considered the school board's expenditure authorization for that school year.
- B. If revisions or modifications in the adopted expenditure budget are determined to be advisable by the administration, the superintendent shall recommend the proposed changes to the school board. The proposed changes shall be accompanied by sufficient and appropriate background information on the revenue and policy issues involved to allow the school board to make an informed decision. A school board member may also propose modifications on that board member's own motion, provided, however, the school board member is encouraged to review the proposed modifications with the superintendent prior to their being proposed so that the administration may prepare necessary background materials for the school board prior to its consideration of those proposed modifications.
- C. If sufficient funds are not included in the expenditure budget in a particular fund to allow the proposed expenditure, funds for this purpose may not be expended from that fund prior to the adoption of an expenditure budget amendment by the school board to authorize that expenditure for that school year. An amended expenditure shall not exceed the projected revenues available for that purpose in that fund.
- D. The school district's revenue budget shall be amended from time to time during a fiscal year to reflect updated or revised revenue estimates. The superintendent shall make recommendations to the school board for appropriate revisions. If necessary, the school board shall also make necessary revisions in the expenditure budget if it appears that expenditures would otherwise exceed revenues and fund balances in a fund.

Legal References: Minn. Stat. § 123B.77 (Accounting, Budgeting, and Reporting Requirement)

Cross References: MSBA/MASA Model Policy 701 (Establishment and Adoption of School District Budget)

~~MSBA Service Manual, Chapter 7, Education Funding~~

New Policy
Replacing: 3010
First Reading: 08-21-2018
Adopted: 09-18-2018
Revised:

Monthly Committee of the Whole Board Meeting

Duluth Public Schools, ISD 709

Agenda

Tuesday, May 5, 2026

District Services Center

709 Portia Johnson Dr.

Duluth, MN 55811

4:30 PM

1. CALL TO ORDER

2. ROLL CALL

3. AGENDA ITEMS

A. Strategic Plan Alignment

1) Advancing Equity

a. District Analytics Strategy Discussion

2

b. Check and Connect

13

2) Supporting Every Student

a. Social Studies Curriculum Review & Adoption

14

b. Artificial Intelligence Project Update

21

3) Improving Systems

a. ALC Compliance Report and Next Steps

39

B. Teaching, Learning, and Equity Board Summary Report

1) Intra-City Student Council

50

C. Budget Update

1) Updated Fiscal Year 2026-27 Preliminary Budget

54

D. Other

4. ADJOURN

COW Agenda Cover Sheet

Meeting Date: May 5, 2026

Topic: District Analytics

Presenter(s): Ray Queener

Attachment: Yes

Brief Summary of Presentation or Topic (no more than a few sentences):

We are presenting a summary of the demographics study that was conducted by Teamworks. This study is an overview of our growth, projections and enrollment and should be used by the district to strategically consider space and facilities issues for our schools and community.

This Requires School Board Approval :

No

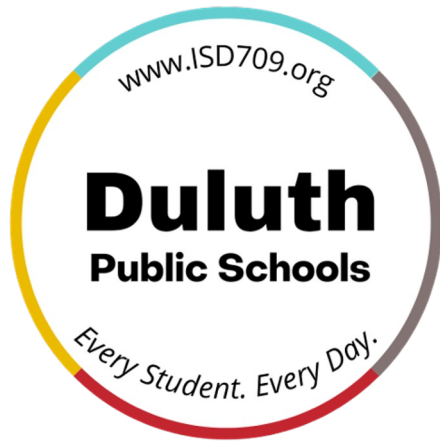

**SCHOOL BOARD COMMITTEE OF
THE WHOLE MEETING**

MAY 05, 2026

DISTRICT ANALYTICS STRATEGY DISCUSSION

Demographic · Housing · Enrollment · Market Share

PREPARED BY TEAMWORKS | EDUCATION LEADERSHIP SOLUTIONS

EXECUTIVE SUMMARY



Realities that must drive every strategic planning conversation

94,884

District Population

+1.4% since 2010

-26.4%

Resident Birth Decline

1,070 → 788 births (2010–2025)

-5.9%

K–12 Enrollment Decline

8,906 → 8,384 (2010–2026)

67.3%

Overall Market Share

Elementary lowest at 63.3%

+8.6%

Combined 10-yr Projection

Development + market share

32.7%

Students Choosing Non-DPS

Private, charter, open enroll

Strategic Bottom Line: Declining births and aging housing stock are structural — they cannot be reversed. Market share is the one variable entirely within district control. A focused market share strategy, alone, has the potential to more than offset every enrollment loss of the past 15 years.

COMMUNITY DEMOGRAPHICS



AGE TRENDS — A Community Growing Older

- 65+ cohort: +47.4% since 2010 — fastest-growing segment
- 65+ projected to reach 21.2% of population by 2030
- 0–4 year olds: -11.7% since 2010; projected -2.5% more by 2030
- 5–14 year olds: -0.5% since 2010; projected -3.4% by 2030
- Median age 37.4 today → rising to 38.7 by 2030

POPULATION BY AGE GROUP (2025 vs. 2030 Projected)

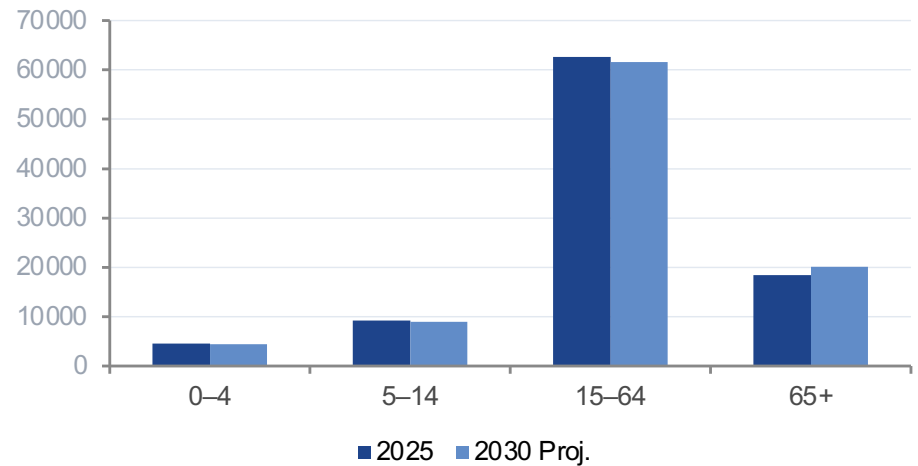

RACE & ETHNICITY — Slow But Steady Diversification

- White population: 84.1% (2025), down from 89.9% in 2010
- BIPOC population grew +56.5% (2010–2025): 8.6% → 13.3%
- Hispanic population grew +69.1% (2010–2025): 1.5% → 2.5%
- Student body: White 75.4% | Multi-Racial 10.7% | Black 4.7% | Hispanic 4.4%

INCOME SNAPSHOT

Median HH income: \$67,361 (2025) → \$72,940 by 2030 | Student HH median: \$84,048
 43% of student families live in households below \$75K | Free/Reduced Lunch: 37.7% | SPED: 22.4%

BIRTH TRENDS — THE UPSTREAM ENROLLMENT SIGNAL



-26.4%

Resident births since 2010
1,070 → 788

Regional Context

Surrounding district births also declined -15.1%.
This is a regional trend.

DISTRICT BIRTH TREND (2010–11 to 2024–25)

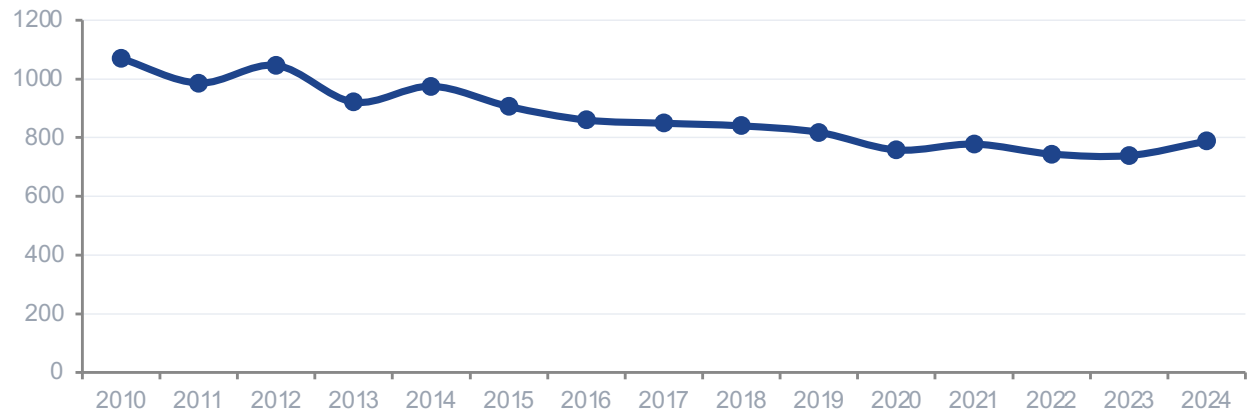

STEEPEST DECLINES

Myers-Wilkins: -50.0%
Congdon: -46.4%
Piedmont: -45.8%
Laura MacArthur: -45.2%

GROWTH AREAS

Lakewood: +75.8%
Homecroft: +9.5%
Lowell: +9.3%

HOUSING CHARACTERISTICS & STUDENT YIELD



HOUSING STOCK COMPOSITION

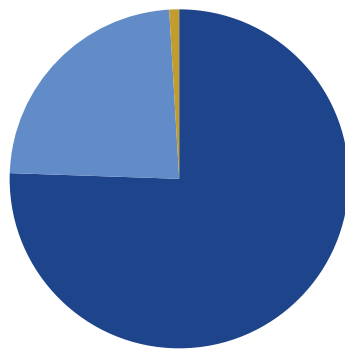

■ Single-Family 75.5%
 ■ Apartment/Rental 23.5%
 ■ Manufactured 0.9%

STUDENT YIELD PER HOUSING UNIT

- Single-Family: 0.24 students/unit
- Apartment/Rental: 0.07 students/unit
- Manufactured Home: 0.20 students/unit
- Yield rates must be embedded in all capacity planning as new development is approved

HOME SALES TRENDS & STRATEGIC CONTEXT

- 3,823 sales since 2020 | avg. price \$122,749
- District-wide price growth: +13.3% since 2010
- Highest growth: Lakewood (+76.6%), Laura MacArthur (+40.3%), Stowe (+32.5%)
- Only decline: Lester Park (-10.7%)
- Aging stock limits organic family attraction through resale market

Strategic Implication: This is a maintenance housing environment, not a growth engine. Target recruitment in Lakewood, Lowell, and other appreciation zones.

\$296K

Avg. Home Value

Single-family

75%

Built Pre-1970

Aging housing stock

91%

Students in SFR

Over 7,300 K-12 students

HISTORICAL ENROLLMENT TRENDS



K-12 ENROLLMENT: 2010-11 vs. 2025-26

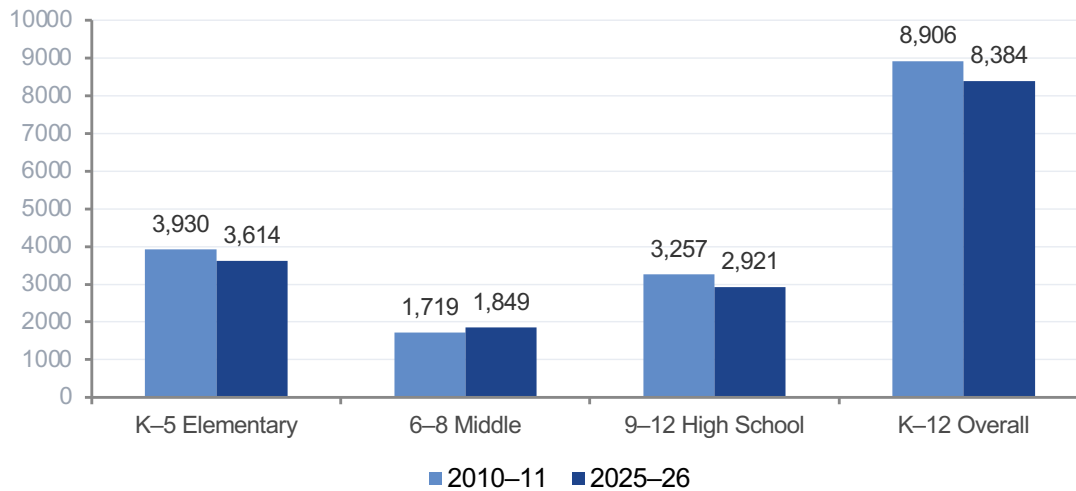

-8.0%
Elementary (K-5)
3,930 → 3,614

+7.6%
Middle (6-8)
1,719 → 1,849

-10.3%
High School (9-12)
3,257 → 2,921

COHORT SURVIVAL RATES (K-12 AVG: 102.1%)

- Elementary 98.0% | Middle 99.5% | High School 108.3%
- High school cohort > 100% signals strong retention and/or inbound transfers

NEIGHBORHOOD SCHOOL ATTENDANCE (2025-26)

- 84% of all K-12 students attend their neighborhood school
- Elementary 77.7% | Middle 94.0% | High School 85.4%

MARKET SHARE ANALYSIS — WHERE STUDENTS ARE GOING



67.3%

Overall K–12 Market Share

63.3%

Elementary (K–5)

65.7%

Middle (6–8)

74.5%

High School (9–12)

WHERE THE OTHER 32.7% ARE GOING

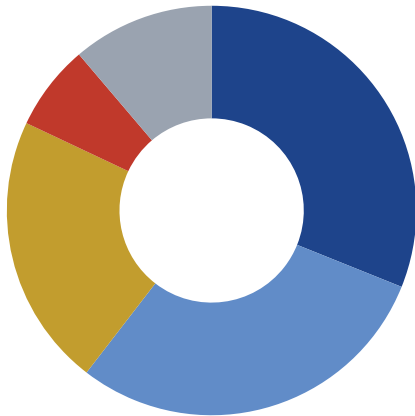

- Private (10.2%)
- Charter (9.6%)
- Open Enroll Out (7.1%)
- Homeschool (2.2%)
- Other (3.6%)

TOP DESTINATIONS — PRIVATE & CHARTER

- Diocese of Duluth: 597 (49.1% of private) | Marshall: 269 (22.1%)
- North Star Academy: 483 (42.0% of charter) | Harbor City: 205 (17.8%)
- Raleigh Primary: 170 (14.9%) | North Shore: 169 (14.7%)

OPEN ENROLLMENT — OUT & IN

- Open Enroll OUT: 844 students | Proctor: 44.9% | Hermantown: 19.9%
- Open Enroll IN: 341 students (4.1% of enrollment)
- Inbound: Lake Superior 33.3% | Proctor 32.1% | Hermantown 22.5%

Strategic Implication: Market share is the most controllable enrollment lever. The district has real regional draw (341 inbound). Strengthening program offerings, communication, and community trust are the highest-leverage actions available.

MARKET SHARE MODELING — THE ACHIEVABLE OPPORTUNITY



+1,219

additional students

if the district reaches a 70% market share floor across all block groups

Resulting overall share: 77.5%

This is not a passive outcome — it requires program investment, strategic communications, and intentional community engagement.

CURRENT MARKET SHARE vs. 70% TARGET

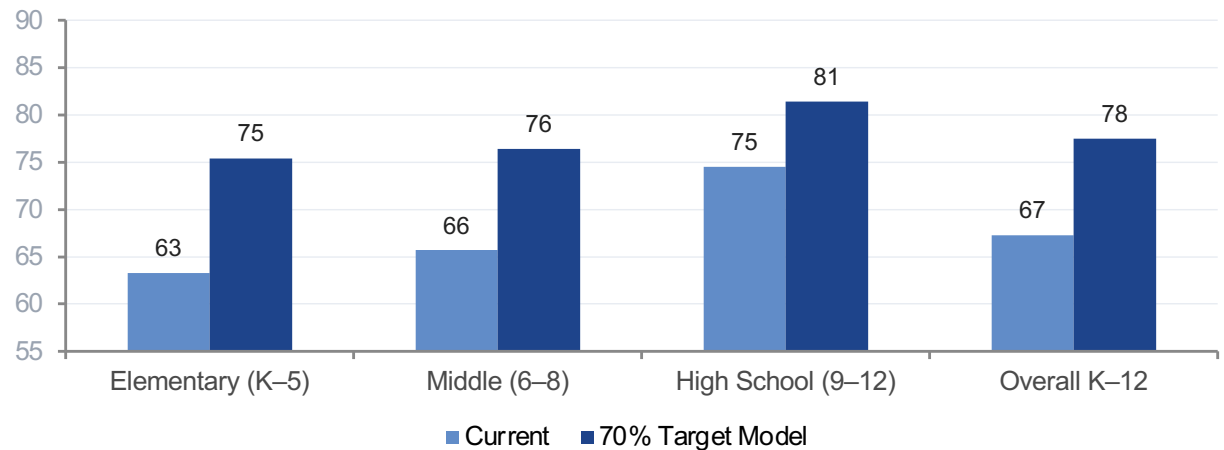

+672
Elementary Gain
 K-5 block groups

+293
Middle Gain
 6-8 block groups

+254
High School Gain
 9-12 block groups

10-YEAR ENROLLMENT PROJECTIONS — FOUR SCENARIOS



K-12 TOTAL ENROLLMENT: 2025-26 BASELINE vs. PROJECTED 2035 SCENARIOS

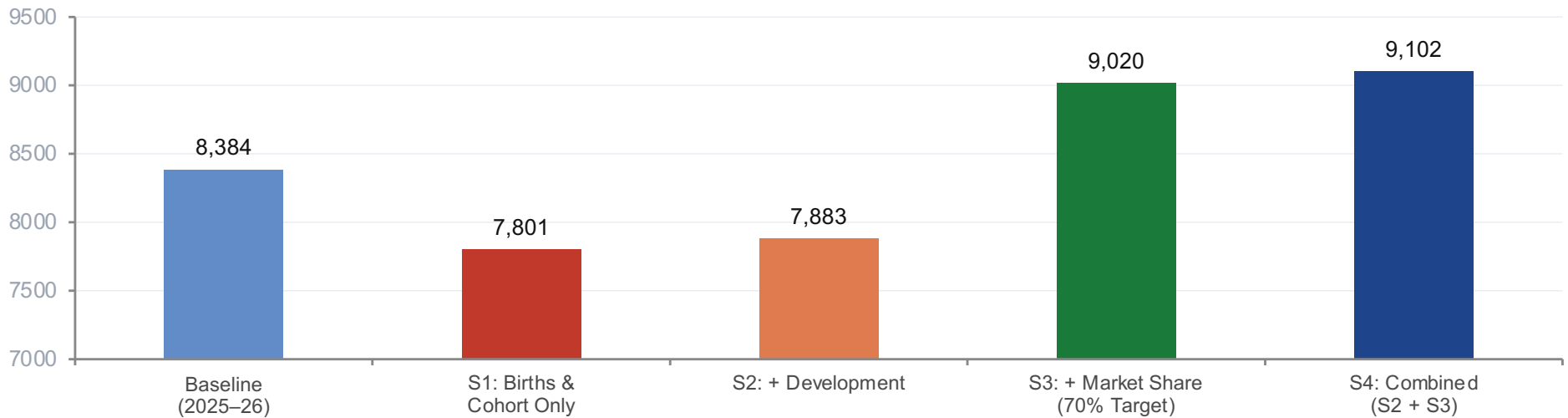

7,801
S1: Births & Cohort
 -7.0%

7,883
S2: + Development
 -6.0%

9,020
S3: + Market Share
 +7.6%

9,102
S4: Combined
 +8.6%

STRATEGIC PRIORITIES

What the data demands from leadership



01

MARKET SHARE RECOVERY

Develop a comprehensive plan to move from 67.3% to 75%+ market share. Identify the specific block groups, grade levels, and competitor alternatives where the district has the most recovery opportunity.

02

BIRTH ZONE STRATEGY

Differentiate capacity, staffing, and programming strategy by attendance area based on birth trends. Growth areas (Lakewood, Lowell, Homecroft) need different investments than areas with 45–50% birth declines.

03

FAMILY RECRUITMENT

Create a proactive family attraction strategy focused on neighborhoods with home price appreciation. This is the one lever that can supplement market share gains with new-resident enrollment.

04

PROGRAM DIFFERENTIATION

Understand why 1,150 resident students choose charter schools and 1,217 choose private schools. Close the program gap and communicate the district's unique value proposition more effectively.

05

CAPACITY PLANNING

Facility utilization data is pending the capacity study. When results arrive, integrate them directly with these projection scenarios — especially the -7% base case — to guide right-sizing decisions.

06

DECIDE WHICH FUTURE TO BUILD

The data presents four scenarios — from -7% to +8.6% over 10 years. The district's future is not fixed. Leadership must choose which scenario to plan and resource toward, then build backward from that goal.

COW Agenda Cover Sheet

Meeting Date: 5/5/26

Topic: Check & Connect

Presenter(s): Sarah Laulunen

Attachment: Verbal Presentation

Brief Summary of Presentation or Topic (no more than a few sentences):

Check & Connect will be providing the “Story Behind the Statistics”. We will have a panel discussion with students, caregivers, staff and MDE about how C&C has truly helped support the “family”.

This Requires School Board Approval : No

COW Agenda Cover Sheet

Meeting Date: May 5th, 2026

Topic: K-12 Social Studies Adoption

Presenter(s): Brenda Spartz, Jen Larva, Susan Schmidt, London Goode

Attachment: [Slides](#)

Brief Summary of Presentation or Topic (no more than a few sentences):

The Social Studies Committees have completed the process of researching and reviewing instructional resources for adoption to meet the new MN Social Studies Standards. The committee is asking for approval from the school board to make the purchase of materials to help meet compliance of the new state standards starting next year.

This Requires School Board Approval : yes

Social Studies Curriculum Review & Adoption

May Committee of the Whole

Brenda Spartz, Jen Larva, London Goode, Susan Schmidt



Major Shifts in the New Social Studies Standards

- **Increased use of inquiry process**
 - Students will be expected to ask questions, investigate problems and explore topics while teachers support their ability to do this
- **Focus on disciplinary literacy skills**
 - Students will be expected to read, write, speak, perform, and think critically as well as learn the content to master standards
- **Addition of Ethnic Studies strand in all grade levels**
 - K-12 standards that focus on the experience and perspective of people of color in our country and around the world
- **Kindergarten-8th grade interdisciplinary model**
 - The K-8 standards now center around a grade-level themes instead of social studies disciplines (history, economics, etc.)

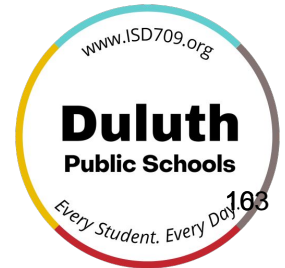

Social Studies Curriculum Adoption Process

- 2022-2023
 - K-12 Committee analyzed the new standards to learn about changes
- 2023-2024
 - K-12 Committee conducted needs assessment with staff, students, and community members
 - [List of priorities](#) from needs assessment
- 2024-2025
 - K-5 Committee reviewed available social studies resources using [Instructional Resources Evaluation Form](#) and [Equity, Diversity, and Inclusion Form](#)
 - K-6 Committee began revising written curriculum to meet new standards
- 2025-2026
 - K-5 Committee is currently piloted [Studies Weekly](#) and [Exploring Social Studies: Minnesota](#)
 - 6-12 Committee made recommendations for changes to course catalog
 - Provided professional development on new Social Studies standards for teaching staff
 - Teacher committees are revising written curriculum to meet new standards
 - Obtained feedback from District Advisory Committee
- 2026-2027
 - Implementation of 2021 Minnesota Social Studies Standards



Social Studies Curriculum Selection

- K-5 Social Studies Committee Selected [Exploring Social Studies: Minnesota](#)
 - Higher ratings in all categories, especially planning, instruction, assessment, culturally responsive instruction, and social justice
 - Full alignment to the MN Social Studies Standards, including all ethnic studies standards
 - Easier for teachers to implement in limited time
 - Less expensive than other options
 - Publishers consulted with representative from Fond du Lac Band of Lake Superior Chippewa
- 6th Grade Continued Yearly Purchase of Northern Lights
 - Reasons and benefits



Adoption Cost

- Exploring Social Studies: MN (K-5): \$244,989.35*
- Northern Lights (6th Grade): \$9,500
- Total Cost: **\$254,489.35**

*The cost for Exploring Social Studies: MN is a one-time purchase until the next adoption. No yearly consumables or subscription fees are necessary.



Contact Information



Brenda Spartz

Elementary Education
Director
brenda.spartz@isd709.org

Jen Larva

Secondary Education
Director
jen.larva@isd709.org

Dr. Dale Uselman

MTSS / Curriculum & Instruction
Coordinator
dale.uselman@isd709.org

Julie Stauber

MTSS / Curriculum & Instruction
Coordinator
julie.stauber@isd709.org

London Goode

Elementary Social Studies
Content Specialist
london.goode@isd709.org

Susan Schmidt

Secondary Social Studies
Content Specialist
susan.schmidt@isd709.org

COW Agenda Cover Sheet

Meeting Date: May 5, 2026

Topic: Artificial Intelligence Project Update

Presenter(s): Greg Krueger and Jen Larva

Attachment: AI Rollout Update for COW May 5, 2026

Brief Summary of Presentation or Topic (no more than a few sentences):

This presentation will update the board on the efforts for stakeholder engagement , including Thought Exchange survey results and future direction related to Artificial Intelligence.

This Requires School Board Approval : No

AI Rollout Update

May 5, 2026

Feedback considered

- Meeting held with University of Minnesota–Duluth professors
- School board listening sessions
- Student survey
- District Advisory Committee March meeting
- Results from secondary teacher survey following professional development

Specific feedback from District Advisory Committee

- Career readiness is important, employers seeking AI skills in candidates and expecting employees to leverage AI
- There is still much uncertainty about AI and its impact on student development
- Concerns about cheating and redesigning instructional approach
- Shift in pedagogy for how to assess student knowledge
- Preparing students for their future is key work of district

Feedback from high school student Thought Exchange

- Environmental impact needs to be considered
- Concerns surrounding ethics and cheating
- Many participants suggest we should use AI sparingly, with a desire to retain a substantial human-driven component of education
- Concerns about teachers use of AI, curricular content generated by AI, and varying quality of generated content
- District needs to consider impacts on mental health

Feedback from high school student Thought Exchange

- Students see how AI can be used as a tutor
- AI helps locate sources for research
- AI helps explain content in ways students understand, in different ways than their teacher
- Can support learning when used responsibly

Excerpts from student Thought Exchange

- “I think generative A.I. is very harmful and dangerous to our environment”
- “I feel like making sure the human/AI balance in submitted work and it's importance is reinforced”
- “I believe that AI does not belong in schools unless all ethical issues are addressed”
- “It can support learning when used responsibly”

Excerpts from student Thought Exchange

- “[AI] Helps me learn how to do things and give me new ways to figure things out that might help me more than what I was taught previously.”
- “AI...takes away from interpersonal relationships between students with their peers and their teachers.”
- “We need to teach people how to responsibly use it”
- “If we want to learn something it will teach us how to learn it”
- “Using AI to boost what you already know or give you ideas on how to start a project is a good use. It allows us to expand our knowledge and learn things that we wouldn't have normally.”

Information from the Staff Survey

Have you seen or heard evidence that students have used AI on assignments and called it their own work?

193 responses

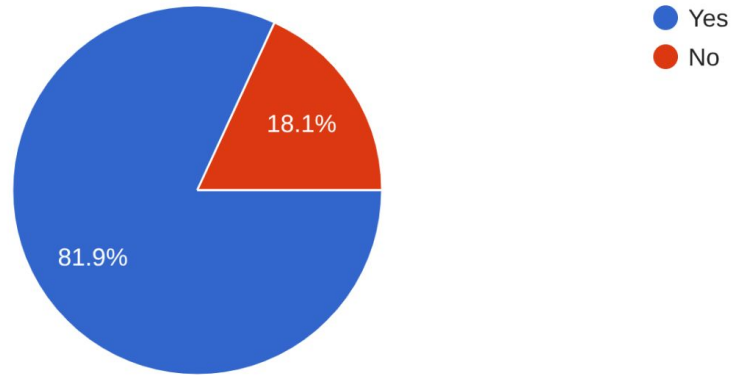

Once granted Gemini access, when are students allowed to use AI tools? (Select the best answer)

193 responses

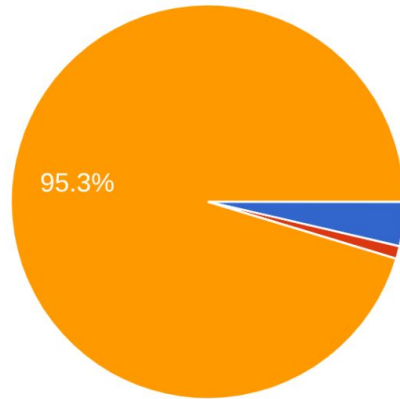

- At any time, for any purpose.
- Only for personal use, outside of schoolwork and never on district devices.
- Only when explicitly permitted by a teacher for a specific assignment.

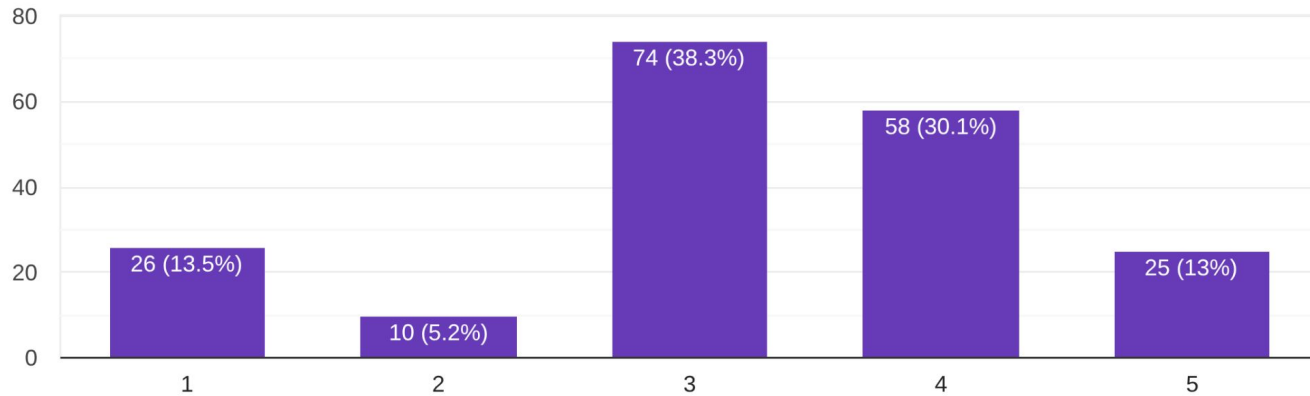

Rate your agreement: The Common Language Tool will help me have conversations with students about their ethical use of AI in my class or with my students.

193 responses



Common Language Tool

Can I Use AI on This Assignment?

Writing	Project	Building Understanding	Planning/ Organization	Creativity
				
<input type="checkbox"/> Topic/Genre Selection	<input type="checkbox"/> Brainstorm	<input type="checkbox"/> Explain a topic	<input type="checkbox"/> Breakdown tasks	<input type="checkbox"/> Idea generation
<input type="checkbox"/> Outline	<input type="checkbox"/> Plan	<input type="checkbox"/> Tutor	<input type="checkbox"/> Timeline development	<input type="checkbox"/> Image generation
<input type="checkbox"/> Research	<input type="checkbox"/> Research	<input type="checkbox"/> Give examples/ non-examples	<input type="checkbox"/> Organize and Summarize	<input type="checkbox"/> Media generation
<input type="checkbox"/> Grammar/Spell Check	<input type="checkbox"/> Creation	<input type="checkbox"/> Review		
<input type="checkbox"/> Draft	<input type="checkbox"/> Feedback	<input type="checkbox"/> Level Text		
<input type="checkbox"/> Feedback	<input type="checkbox"/> Speech or Discussion	<input type="checkbox"/> Summarize Reading		
<input type="checkbox"/> Revise	<input type="checkbox"/> Slide Creation			

<input checked="" type="checkbox"/>	YES
<input type="checkbox"/>	NO

Students are responsible for ensuring that all work reflects their own thinking, learning, and creativity. If unsure, students should ask for clarification before using any AI tool. Students may not use artificial intelligence tools, unless the teacher has given explicit permission and AI generated content is properly cited when applicable.

Misuse of AI is a form of academic dishonesty and may result in consequences.

Syllabus Statement

Students are responsible for ensuring that all work reflects their own thinking, learning, and creativity. If unsure, students should ask for clarification before using any AI tool. Students may not use artificial intelligence tools, unless the teacher has given explicit permission and AI generated content is properly cited when applicable. Misuse of AI is a form of academic dishonesty and may result in consequences.

Summary of what we've heard

- District should focus on intentional use of AI
- Seeking AI use be isolated to purposeful lessons
- Concerns about equity of access
- Environmental considerations
- Perceived overuse of technology, desire to limit screen time
- Potential for decline of critical thinking skills
- Societal experiment with undetermined results
- Ability to tutor students and enhance learning, help learn in new ways

Next steps

- Continued focus on building staff capacity and student readiness as we begin school in fall
- No student AI rollout date planned at this time
- Messaging to parents about district's plan and efforts
- William Grube (K-12 AI trainer) coming onsite to train teachers September 1
- Improvements to District AI website within Digital Innovation department
- Continue examining research around AI use and student learning & development
- Engage with AI Champions and peer districts
- Engage with student groups

Student and staff preparation

- Student lesson had been completed before February
- District Office AI training held in February
- Principal AI trainings held in March
- Continued work with AI in department meetings
- Contracting with Gruvy Education for next fall
- Continued student training

Key Messaging for Our Community

Why We Are Implementing AI

- **Preparing Students for the Future:** Employers are seeking AI-literate candidates. Fluency in these tools is becoming a vital skill for future career efficiency.
- **Deepening Critical Thinking:** When used appropriately, AI helps students gain a deeper understanding and encourages independent thinking.
- **Empowering Educators:** AI acts as an assistant, helping teachers with administrative tasks like standard alignment. This gives them more time for direct student interaction.
- **Proactive Response:** We are addressing the reality of AI usage in society; strict detection is no longer a viable sole strategy.

THE "SOCRATIC TUTOR" METHOD
(For Student AI Use)

Don't ban AI. **Teach students** how to use it the right way.

→ Shift AI from answer-giving ~~X~~ → thinking support

STUDENT PROMPT TEMPLATE

"Act as my expert Algebra 1 tutor. My goal is to truly understand how to solve the math problems I give you.

Rule 1: NEVER give me the final answer or all the steps at once.

Rule 2: Ask me a guiding question to help me figure out the first step. Wait for my response.

Rule 3: If I make a mistake, point it out gently and ask me to correct it before moving on.

Here is my first problem: [Insert Problem]"

HOW TO ENFORCE IT

- Require students to submit their AI chat link
- Grade the conversation, not just the answer
- Look for effort, thinking, and participation
- Reward the problem-solving process

WHAT THIS BUILDS

- Independent thinking
- Deeper understanding
- Academic integrity
- Confidence in problem solving

EACH ONE TEACH ONE @ellecrens324

Questions?

COW Agenda Cover Sheet

Meeting Date: May 5, 2026

Topic: ALC Compliance Report and Next Steps

Presenter(s): Jen Larva

Attachment:  Duluth review report with findings_April 20 2026.pdf

 MDE_Action_Plan_Final.xlsx

 Response to MDE

Brief Summary of Presentation or Topic (no more than a few sentences):

This report updates the board on the MDE ALC desk review finding and sanctions., the prepared response for MDE, and Corrective Action plan.

This Requires School Board Approval : No



Minnesota Department of Education
400 NE Stinson Blvd.
Minneapolis, MN 55413

April 20, 2026

Nathan Glockle
Area Learning Center
Duluth Public School District
11 Superior Street, Ste 450
Duluth, MN 55802-2013

Greetings,

As stated in the August 25, 2025, letter to the district, the Minnesota Department of Education (MDE), through the Career and College Success Division, initiated monitoring of the district's Area Learning Center (ALC) programs to review compliance with all applicable state statutes to ensure the programs maintain approved status. This review has gathered information regarding the statutory obligations of the ALC under Minnesota Statutes 2024, sections 123A.05 to 123A.08 - State Approved Alternative Programs, 124D.68 - Graduation Incentives, and 124D.128 - Learning Year Program. Minnesota Statutes 2024, section 123A.09, confers the authority of the commissioner of education to designate and approve that state-approved alternative programs (SAAPs) are meeting the provisions under sections 123A.05 to 123A.08.

The review is in response to the district's use of a Google form that indicated students could complete a short submission to be in attendance for independent study. This letter is a response to the documents submitted with findings and recommendations. Please find attached a monitoring report and statutory references.

In January 2026, MDE expanded monitoring request based on initial review of the documents provided in the first portion of the desk review and additional information received by Duluth Public School District regarding program design for the ALC including student schedule, teacher instructional time, and comprehensive programming.

MDE would like to take this opportunity to thank you and staff members of Duluth Public School District for their cooperation and assistance during the review process. If you have any questions regarding the enclosed information, please do not hesitate to contact MDE.AlternativeLearning@state.mn.us.

Sincerely,

Christy Irrgang
Alternative Education Specialist

CC: Eric Billiet, Supervisor, Career and College Success Division
Sally Reynolds, Director, Career and COLlege Success Division
Anthony Bonds, Assistant Superintendent, Duluth Public School District

Equal Opportunity Employer

Monitoring Report

Summary of Monitoring Process

MDE staff who participated in the monitoring process include Christy Irrgang, Eric Billiet, and Sally Reynolds of Career and College Success Division. Documents necessary for monitoring, including a list of students enrolled in independent study (IS) for fiscal year (FY) 2023 and FY 2024 and teacher schedules, licenses, and file folder numbers if providing IS instruction for FY 2023 and FY 2024, were requested by September 26, 2025. The district submitted the documents in part on September 11, 2025. On November 18, 2025, MDE indicated that continual learning plans (CLP) for each student participating in IS programming for FY 2023 and FY 2024 were needed to proceed with the desk review, and that the complete documents were needed by December 5. On December 22, 2025, MDE requested clarification if the documents submitted included complete records of the requested documents. Following several clarification emails between MDE and the district, MDE indicated that the district needed to submit evidence of the full requirements of the continual learning plans. This request was fulfilled in part by January 5, 2026, and the information is missing some required elements of the CLP.

In January 2025, the district reached out to school finance for technical assistance on reporting a four-day week and instructional time that would be labeled as “Outreach” in the SIS and count for instructional time, to bring the total instructional minutes for the day to 510. As a result of that question, additional conversation occurred between MDE staff, district student accounting staff, and district program staff. The result of this conversation indicated the need for additional information from the district in an expansion of the monitoring. MDE sent a letter on January 26 requesting, from the ALC programming in FY 2024 and FY 2025, transcripts, teacher and student schedules, enrollment procedures, and course catalog. The documents were requested by February 27, 2026. The district completed the request by February 6, 2026.

Elements Reviewed

Critical Element I — Organization and Administration

Sub Element	Status	Statute / Rule / Guidance
<p>The ALC must have received approval from MDE to operate as a SAAP. The ALC must be a site on MDE-ORG.</p> <p>"Site" means a separate facility. A program within a facility or within a district, such as a “school within a school” is a separate ALC site once the school board recognizes it as a site.</p>	<p><input type="checkbox"/> In Compliance</p> <p><input checked="" type="checkbox"/> Partial Compliance w/recommendations</p> <p><input type="checkbox"/> Not in compliance w/ findings</p>	<p>Minn. Stat. 123A.09</p> <p>Minn. Stat. 123B.04 subd. 1</p> <p>Minn. Stat. 124D.128, subd. 2</p>

Sub Element	Status	Statute / Rule / Guidance
<p>The ALC provides comprehensive educational services to enrolled secondary students throughout the entire year, including a daytime program for both high school and middle level.</p>	<input type="checkbox"/> In Compliance <input checked="" type="checkbox"/> Partial Compliance w/recommendations <input type="checkbox"/> Not in compliance w/ findings	Minn. Stat. 123A.05, subd. 1(b) Minn. Stat. 123A.06, subd. 3 Minn. Stat. 124D.128
<p>The ALC must develop and maintain a separate record system that permits identification of membership attributable to students participating in the program. The record system and identification must ensure that the program will not have the effect of increasing the total average daily membership attributable to an individual student as a result of a learning year program. The record system must include the date the student originally enrolled in a learning year program, the student's grade level, the date of each grade promotion, the average daily membership generated in each grade level, the number of credits or standards earned, and the number needed to graduate.</p>	<input type="checkbox"/> In Compliance <input type="checkbox"/> Partial Compliance w/recommendations <input checked="" type="checkbox"/> Not in compliance w/ findings	Minn. Stat. 124D.128, subd. 2

The following compliance issues were found.

- Online instruction is being implemented in a manner that does not align with statutory requirements or MDE guidance for state-approved alternative programs.
 - There is a lack of clarity on the attendance expectations and how records are kept to reflect the attendance policies and procedures.
- The ALC is operating on a four-day instructional week without receiving approval for a flexible learning year.
- The district does not follow IS requirements.
 - Enrollment records cannot blend between seat based and IS instruction in one record.
 - Students should not be required to complete a certain amount of “contact hours” to pass the class. They should be awarded credit when they pass and marked for attendance and membership per the [Independent Study Membership Hours Calculation for State-Approved Alternative Programs](#).
 - IS is blended into the school day schedule, and there is a lack of clarity on how the district is differentiating between these enrollment records and documented time and effort of teachers.
- Course catalog does not include some of the courses for which teachers are assigned to teach.
 - Student transcripts reflect IS courses that are not included in the annual IS report.

- The district’s recordkeeping system does not clearly identify student enrollment by course or instructional activity, nor does it demonstrate how average daily membership is generated and connected to coursework.
 - Teacher schedules are insufficiently documented to support instructional delivery and membership claims.
 - In some cases, students took 13 or more courses over a year in IS, and further data would be needed to analyze student schedules, MARSS record and ADM generated, and teacher instruction and attendance.

Critical Element II — Admissions

Sub Element	Status	Statute / Rule / Guidance
<p>A continual learning plan must be developed at least annually for each student with the participation of the student, parent or guardian, teachers, and other staff; each participant must sign and date the plan. The plan must specify the learning experiences that must occur during the entire fiscal year and are necessary for grade progression or, for secondary students, graduation.</p> <p>The CLP must include:</p> <ul style="list-style-type: none"> • the student's learning objectives and experiences, including courses or credits the student plans to complete each year and, for a secondary student, the graduation requirements the student must complete; • the assessment measurements used to evaluate a student's objectives; • requirements for grade level or other appropriate progression; and • for students generating more than one average daily membership in a given grade, an indication of which objectives were unmet. 	<ul style="list-style-type: none"> <input type="checkbox"/> In Compliance <input type="checkbox"/> Partial Compliance w/recommendations <input checked="" type="checkbox"/> Not in compliance w/ findings 	<p>Minn. Stat. 124D.128, subd. 3</p> <p>Minn Stat. 126C.05, subd. 15</p>

The following compliance issues were found.

- The district was unable to provide valid, compliant CLPs for enrolled students.
 - CLPs did not meet statutory requirements for annual development, participant involvement, signatures, or required content elements.
 - The district submitted the forms but not the completed CLPs with graduation requirements and courses. Clarification was sought on the completion of the records but the district was unable to

provide signed copies of the completed CLPs. In some cases it appears the referral form serves as the CLP.

Critical Element III – Programming

Sub Element	Status	Statute / Rule / Guidance
Districts providing online instruction in the ALC must meet the requirements of the online and digital instruction act and all SAAP statutes.	<input type="checkbox"/> In Compliance <input type="checkbox"/> Partial Compliance w/recommendations <input checked="" type="checkbox"/> Not in compliance w/ findings	Online Instruction in State-Approved Alternative Programs
Persons providing instruction are appropriately licensed with a Minnesota teaching license in the field and grade level being taught.	<input type="checkbox"/> In Compliance <input type="checkbox"/> Partial Compliance w/recommendations <input checked="" type="checkbox"/> Not in compliance w/ findings	Minn. Stat. 120A.22, subd. 10

The following compliance issues were found.

- Student instructional modality (seat-based, IS, or online instruction), schedules, and teacher contact time are not consistently or clearly documented across CLPs and teacher schedules.
- Instruction is provided in subject areas without appropriately licensed staff. Specifically, there is no licensed teacher assigned for chemistry instruction, and instruction in health, physical education, and music is provided by individuals without appropriate licensure.
- Teacher contact time was counted when students fill out a Google form, which does not meet the requirements for attendance for membership in independent study.

Next Steps

1. The district’s ALC will be reclassified as an alternative learning program starting July 1, 2026. The targeted services programs will be closed as of July 1, 2026. The independent study approval will be discontinued as of July 1, 2026.
2. The district must complete a full ALC application process, independent study application process, and targeted services application process.
3. Within thirty (30) days of receipt of this letter, the district must submit an action plan addressing compliance issues listed above. The plan should include specific steps, responsible staff, timelines for implementation, and evidence the district will provide to MDE to verify completion of tasks.

Failure to submit the required information and corrective action plan within the stated timelines may result in continued noncompliance and could place the program’s approval status at risk for fiscal year 2027.

Written Response

A response to this letter shall be directed towards MDE.AlternativeLearning@state.mn.us within 30 days of the letter's receipt indicating the action plan to complete the above items. The district is able to request a meeting with MDE within 30 days to receive any guidance on writing the action plan. We appreciate the time and effort to participate in this review process and look forward to continued partnership in supporting your program.

**Duluth Public Schools - Area Learning Center
Corrective Action Plan Dashboard**

Submitted to: Minnesota Department of Education
Prepared by: Jen Larva, Director of Secondary Education

Total Actions	20
In Progress	9
Not Started	10
Complete	1

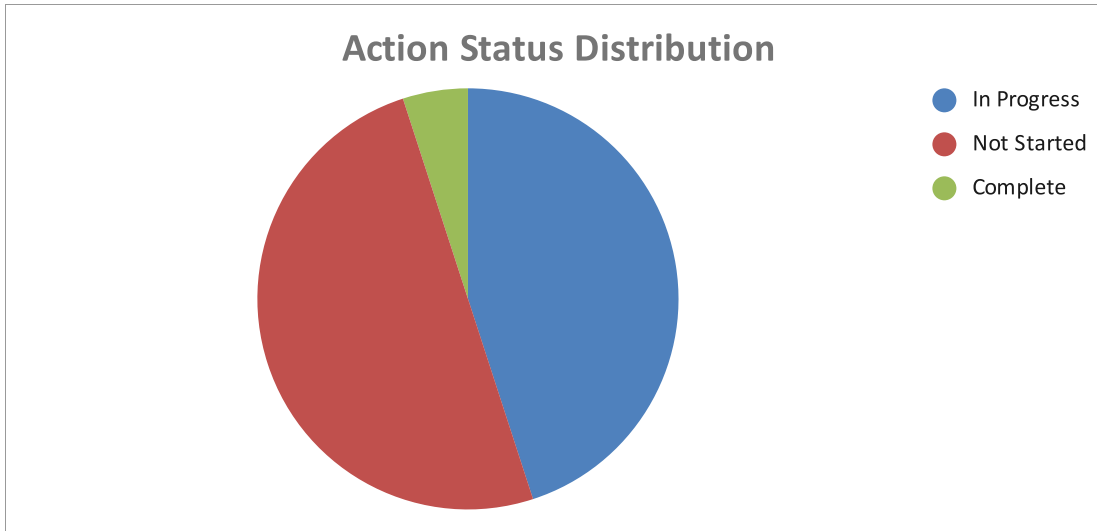

Duluth Public Schools

Official Response and Corrective Action Plan Submission

To: Minnesota Department of Education – Career and College Success Division

Attention: Christy Irrgang, Alternative Education Specialist

Date: April 30, 2026

Dear Ms. Irrgang,

On behalf of Duluth Public Schools, thank you for the comprehensive monitoring review of our Area Learning Center (ALC) programs and for the detailed feedback provided in your letter dated April 20, 2026. We appreciate the clarity of the findings and the opportunity to strengthen our systems to ensure full alignment with Minnesota statutes governing State-Approved Alternative Programs (SAAPs). We would also like to extend our sincere appreciation to you and Eric Billiet for meeting with our team virtually on Thursday, April 23, to answer questions and provide additional guidance regarding the findings and next steps. We value this support and the collaborative approach taken by MDE, and we look forward to continuing this partnership as we move forward.

We submit this response and accompanying Corrective Action Plan with a clear commitment to bring all ALC programming into full statutory compliance while preserving high-quality, student-centered pathways to graduation. The district acknowledges the findings across the three critical elements of Organization and Administration, Admissions (Continual Learning Plans), and Programming (Instructional Delivery and Licensure). The review identified several systemic issues, including a lack of clarity and separation between instructional models, inconsistent and noncompliant recordkeeping and ADM reporting practices, incomplete and noncompliant Continual Learning Plans, and misalignment between course offerings, staffing, and licensure requirements. We recognize that these issues reflect system-level misalignment rather than isolated concerns and therefore require a comprehensive, system-level response.

Since the time of the review, there has been a change in site leadership, and responsibility for implementation of corrective actions now rests with district leadership under the supervision of the Director of Secondary Education. This transition provides an important opportunity to re-establish clear systems of accountability, align program design with statutory expectations, and strengthen oversight of alternative programming across the district. While we are building upon work already initiated, this plan reflects a district-led and sustainable approach to compliance moving forward.

The district's corrective actions are centered on three primary areas. First, we are undertaking a structural realignment of the ALC program to ensure clear separation of instructional models, including seat-based instruction (School 611) and independent study (School 616), supported by a compliant and well-documented master schedule aligned to learning year requirements. This includes the submission of a Flexible Learning Year application for a one-year extension and implementation of a redesigned master schedule for the 2026–27 school year to ensure accurate and transparent ADM generation tied directly to instructional delivery. Second, we are implementing statutorily compliant systems for Continual Learning Plans, Independent Study programming, and student recordkeeping. New CLP processes are being developed to ensure that plans are completed annually, include all required elements, and are

created collaboratively with students, families, and staff. Independent Study programming is being aligned to competency-based credit attainment with clearly documented teacher-student engagement, and student record systems are being redesigned to ensure alignment between enrollment, coursework, attendance, and ADM reporting. Third, we are ensuring the integrity of instruction by taking immediate steps to align all course offerings with appropriately licensed staff and to ensure that online and independent learning models meet state requirements for instructional quality and engagement. A full licensure audit is currently underway, and staffing adjustments will be completed prior to the 2026–27 school year.

We respectfully request continued guidance as we complete the reapplication process for ALC, Independent Study, and Targeted Services programming, ensure alignment with all statutory and program approval requirements, and implement sustainable systems that meet both compliance expectations and student needs. We value our partnership with the Minnesota Department of Education and are committed to working collaboratively throughout this process. We welcome the opportunity to continue dialogue with your team to review progress, receive feedback, and ensure alignment throughout implementation.

Duluth Public Schools is fully committed to ensuring that our alternative learning programs meet the highest standards of compliance, integrity, and student-centered practice. This Corrective Action Plan reflects not only our response to identified findings, but our commitment to building a stronger, more coherent system that supports all learners in achieving graduation and postsecondary success. Thank you for your partnership and continued support in this work.

Sincerely,

Jennifer Larva, Director of Secondary Education

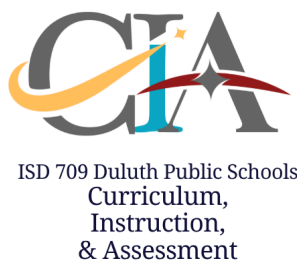

Jennifer Larva, Ed.S.

Director of Secondary Education

218-336-8700 ext. 1007

jennifer.larva@isd709.org

709 Portia Johnson Drive
Duluth, Minnesota 55811

COW Agenda Cover Sheet

Meeting Date: May 5, 2026

Topic: Intra-city Student Council (ICSC)

Presenter(s): Jen Larva

Attachment:  Board Summary Report: Intra-city student council

Brief Summary of Presentation or Topic (no more than a few sentences):

This report updates the board on ICSC progress.

This Requires School Board Approval : No

Board Summary Report: Intra-city Student Council

This report is designed for Department or Program Leaders to provide a concise, high-level overview of their area's status, activities, and future plans to the School Board.

Report Identification

Field	Information
Department/Program Name:	Secondary
Report Title:	Update on Intra-city Student Council
Report Leader:	Jen Larva
Date Submitted:	May 1, 2026
Date of Board Meeting:	May 5, 2026

Put Summary Report

I. Program Objectives & Goals (What are we trying to achieve?)

The Big Picture The Intra-City Student Council gives students from our high schools a direct way to talk to district leaders. Our goal is to make sure student perspectives are a regular part of how we make decisions.

Our Main Goals

- **Give Students a Voice:** Create a direct line for students to tell district leaders what is really happening in their schools.
- **Improve School Rules:** Let students give feedback on policies and programs before they are finalized.
- **Build Leadership Skills:** Help students from different backgrounds learn how to lead and work as a team.
- **Create a Better School Environment:** Make schools feel more inclusive and safe by listening to and acting on student concerns.

What We are Working on Right Now

- **Getting Started:** Moving from the planning stage to holding regular meetings (starting with the first group meeting on April 29).
- **Full Participation:** Making sure we have student representation
- **Setting a Routine:** Determining how meetings will run and how students will pick the topics they want to discuss.
- **Clear Communication:** Setting up a system (like a shared email and news updates) so the whole district knows what the council is working on.

II. Key Actions & Activities (What have we done recently?)

- **Action 1: Refined Program Design and Logistics.** While this project took longer to launch than originally intended, we used the "pause" to ensure the program would actually work for students. Early efforts included meeting with School Board Student Representatives to set a vision and create an application process. We then spent time restructuring the program to fit within the regular academic day and school calendar. This was a critical step to ensure that underclassmen could participate and that transportation needs were addressed so every student has a way to attend.
- **Action 2: Held the First Cross-City Meeting on April 29.** After navigating several scheduling conflicts on previous "Opportunity Days," we successfully brought students from the different sites together for the first time on April 29. It is important to note that because the planning phase was handled by district leadership and student board reps, the students currently on the council are now stepping into this new structure for the first time to begin their work.
- **Action 3: Transitioned Leadership to Schools.** With the first meeting complete, the project has been turned over to the high school principals who will work with their building staff to set agendas and

invite district participation. They will now lead the council's day-to-day activities, ensuring the work remains student-centered and grounded in each school building.

III. Outcomes & Results (What was the impact?)

The launch of the Intra-City Student Council on April 29 was successful. Five students from East High School, accompanied by the MTSS coordinator, traveled to Denfeld High School to join 18 Denfeld students and the Student Government coordinator for an afternoon of collaboration. The energy in the room was positive as students broke into small groups to discuss why this council matters.

The most impactful result was the students' own realization that they are stronger together. They shared that a city-wide council gives them a "collective voice" that can actually reach district leadership and the School Board. Beyond just talking about policy, the students focused on community building. They noted that meeting peers from across town helps break down old stereotypes and turns the cross-town rivalry into a positive partnership.

By the end of the meeting, the impact was visible through a list of student-led ideas. They moved quickly from "getting to know each other" to brainstorming real projects, such as joint fundraising for local non-profits, friendly school-spirit competitions like city-wide medallion hunts, and winter community events. The meeting proved that when we provide the space, our students are eager to lead and connect across school boundaries.

IV. Next Steps & Future Focus (What is planned for the future?)

- **Next Step 1: Formalize the Communication Loop.** To ensure student voices reach the highest level of leadership, the communication link to the School Board will now come directly through each site's School Board Student Representative. They will be responsible for reporting on the council's progress, priorities, and recommendations.
- **Next Step 2: Summer Planning & Governance (August 2026).** In early August, students and staff partners will meet to finalize the council's structure for the new school year. This includes launching a formal application process to ensure balanced representation (10 students each from East, Denfeld, and the ALC) and establishing a bi-weekly meeting schedule that fits within the academic day to ensure all students can participate.
- **Future Focus Area: Service and Community Building.** A major highlight of the council's future work will be launching district-wide community-building initiatives. Students are planning joint service projects, such as fundraising for local non-profits, and "friendly rivalry" events—like city-wide medallion hunts and winter competitions—to break down barriers between schools and foster a unified district spirit.
- **Future Focus Area: Shift to Student-Led Design.** This project is officially "flipping" from district-led initiative to one that is student-designed and student-driven. Moving forward, district and school site leadership will serve as partners who provide support and resources only upon invitation from the students. This ensures the council's work is authentic to the students' own vision.

COW Agenda Cover Sheet

Meeting Date: Tuesday, May 5, 2026

Topic: Updated Fiscal Year 2026-27 Preliminary Budget

Presenter(s): Simone Zunich, Executive Director of Finance & Business Services

Attachment: Yes - Fiscal Year 27 Budget Assumption - COW 05.05.26 Brief

Summary of Presentation or Topic (no more than a few sentences):

Simone Zunich will provide an update on the preliminary 2026-27 budget ahead of potential adoption in June.

This Requires School Board Approval :

In June, 2026

The logo is a circular emblem with a white center and a dark outer ring. The website address 'www.ISD709.org' is written in a curved path at the top of the ring. The school's name 'Duluth Public Schools' is centered in the white area. The motto 'Every Student. Every Day.' is written in a curved path at the bottom of the ring.

www.ISD709.org

Duluth
Public Schools

Every Student. Every Day.

UPDATES TO FISCAL YEAR 2026-27 PRELIMINARY BUDGET FINANCIAL PLANNING & PROJECTIONS

Prepared by: Simone Zunich

Presented: COW Meeting, May 5, 2026

Updates since April 7, 2026 Committee of the Whole:

We have finalized three key adjustments to the preliminary FY27 budget:

- **Fuel Services:** Increased expenditure by **\$85,000** to stabilize transportation operations.
- **Title Grants:** Reconciled all Title funding streams to align with current federal award notices.
- **Special Education:** Updated the R&E revenue projection to **\$32,995,988.74**, based on the state's latest 4.13 calculator scenario.

Federal Programs Funding - District Portion

Year	Title I	Title II	Title III	Title IV	Title ID
2023-24	\$2,710,620	\$288,435	\$7,710	\$141,716	\$175,925
2024-25	\$2,812,634	\$360,002	\$7,656	\$180,256 Transferred to Title I	\$124,566
2025-26	\$2,852,008	\$265,580	\$9,291	\$165,280 Transferred to Title I	\$83,264
2026-27	\$2,354,409	\$233,274	\$8,617	\$150,758 Transferred to Title I	TBD

Student Enrollment & Basic Revenue

Average Daily Membership (ADM): Projected at **8,175** (Increase from 8,125 in FY 26).

Basic Formula Allowance: Projected at **2.69%** increase or \$7,682 per pupil

Levy Updates: Revenue updated based on Pay 25 and Pay 26 cycles.

Compensatory Aid: * Currently budgeted at **\$9,312,178** (based on MDE report).

Special Education Funding

FY 27 Revenue Projection: \$27,530,933.

FY 26 Revenue Revision: Updated to \$31,341,962.

Special Education General Fund Impact: * Currently accounts for **40%** of general fund programs.

- Setting 4 costs estimated between **\$500,000 – \$1,000,000**.

Personnel & Benefit Assumptions

Staff: 2.5% average rollover applied

Lane Changes: Budgeted at 1.8%

Insurance Premiums: 15% estimated increase projected for both **Health** and **Liability** insurance

New Mandatory Obligations (Analytics Objects):

- **Minnesota Family Medical Leave Act Paid Leave (MFMLA) (Obj 219): 5%**
- **Summer Unemployment (Obj 281): 5%**
- **Fund 02 (Food & Nutrition): 5% for Obj 281**

Facilities & Site-Specific Needs

Inflation Strategy: 2.26% inflation applied *only* to Capital Projects (per Fed Reserve 5-yr projection)

- *Note:* Purchased services and supplies held flat to FY 26 levels

First Street Additional Staffing:

- **1st St downtown:** \$350,000 (3.0 FTE)
- **Support:** \$150,000 (2 Custodians, 1 PT Clerical)
- *Note:* These assumptions may require further increases/decreases

Unfunded Mandates & Contract Reviews

READ Act: Lane change costs of approx. **\$650,000** for FY 26 and and \$1,200,000 for FY 27.

MFMLA: While state-funded, the district must absorb the cost of substitutes.

Summer Unemployment: Funded by state through the end of FY 27.

Efficiency Spotlight: * Kelly Education: Contracted costs were \$1.2M in FY 25.

- Analysis shows the district would pay ~33% more if handled internally; current contract represents a significant saving.

Financial Outlook & Risk Assessment

Spending Trends:

- FY 25 Overspend: **\$7,000,000**
- FY 26 Projected Overspend: **Minimum \$4,207,549**
- FY 27 Planned Budget Reductions: **\$4,000,000**

Key Concerns:

- Special Education cost volatility
- Risk of **Statutory Operating Debt (SOD)** due to general fund depletion

PROPOSED FISCAL YEAR 2026/2027 BUDGET

REVENUES	Proposed FY 2027 Budget	EXPENDITURES	Proposed FY 2027 Budget	Dollar Change
01 General Fund	\$154,322,705.00	01 General Fund	\$158,179,470.00	-\$3,856,765
02 Food Service	\$6,283,279.00	02 Food Service	\$6,365,884.00	-\$82,605
04 Community Service	\$7,983,518.00	04 Community Service	\$7,855,857.00	\$127,661
06 Construction		06 Construction		\$0
07 Debt Service	\$28,913,419.00	07 Debt Service	\$28,453,464.00	\$459,955
08 Trust	\$305,000.00	08 Trust	\$285,842.00	\$19,158
20 Internal Service	\$1,201,126.00	20 Internal Service	\$1,309,828.00	-\$108,702
79 Student Activities	\$523,886.00	79 Student Activities	\$438,705.00	\$85,181
Subtotal - Revenues	\$199,532,933.00	Subtotal - Expenditures	\$202,889,050.00	-\$3,356,117

Questions & Concerns?

Policy Committee Meeting
Duluth Public Schools, ISD 709
Agenda
Tuesday, May 12, 2026
District Services Center
709 Portia Johnson Dr.
Duluth, MN 55811
4:30 PM

- 1. AGENDA ITEMS**
- 2. POLICIES FOR FIRST READING**
- 3. POLICIES FOR SECOND READING**
- 4. POLICIES FOR REVIEW**
 - A. 306 Administrator Code of Ethics 2
 - B. 413 Harassment and Violence 4
 - C. 511 Fundraising 13
 - D. 606 Textbooks and Instructional Materials 15
 - E. 701 Establishment and Adoption of School District Budget 18
 - F. 701.1 Modification of School District Budget 20
- 5. REGULATIONS AND FORMS - Informational**
 - A. 413R Harassment Complaint Form 21
 - B. 511R Fundraising 22
- 6. OTHER**

306 ADMINISTRATOR CODE OF ETHICS

I. PURPOSE

The purpose of this policy is to establish the requirements of the school board that school administrators adhere to the standards of ethics and professional conduct in this policy and Minnesota law.

II. GENERAL STATEMENT OF POLICY

The standards of professional conduct are as follows:

- A. A school administrator must provide professional educational services in a nondiscriminatory manner.
- B. A school administrator must take reasonable action to protect students and staff from conditions harmful to health and safety.
- C. A school administrator must take reasonable action to provide an atmosphere conducive to learning.
- D. A school administrator must not use professional relationships with students, parents and caregivers, staff, or colleagues to private advantage.
- E. A school administrator must disclose confidential information about individuals only when a compelling professional purpose is served in accordance with state and federal laws and school district policies.
- F. A school administrator must not knowingly falsify or misrepresent records or facts relating to the administrator's qualifications or to the qualifications of other staff or personnel.
- G. A school administrator must not knowingly make false or malicious statements about students, students' families, staff, or colleagues.
- H. A school administrator must not accept gratuities, gifts, or favors that impair professional judgment, nor offer any favor, service, or item of value to obtain special advantage.
- I. A school administrator must only accept a contract for a position when licensed for the position or when a school district is issued a variance by the Minnesota Board of School Administrators.
- J. A school administrator, in filling positions requiring licensure, must employ, recommend for employment, and assign only appropriately licensed personnel, or persons for whom the school district has been issued a variance by the appropriate state board or agency, unless, after making reasonable efforts to obtain a variance, an appropriately licensed person cannot be assigned and the position must be filled to meet a legitimate emergency educational need.
- K. A school administrator must not engage in conduct involving dishonesty, fraud, or misrepresentation in the performance of professional duties.

~~A. An educational administrator's professional behavior must conform to an ethical code. The code must be idealistic and at the same time practical, so that it can apply reasonably to all educational administrators. The administrator acknowledges that the schools belong to the public they serve for the purpose of providing educational opportunities to all. However, the administrator assumes responsibility for providing professional leadership in the school and community. This responsibility requires the administrator to maintain standards of exemplary professional conduct. It must be recognized that the administrator's actions will be viewed and appraised by the community, professional associates, and students. To these ends, the administrator must subscribe to the following standards.~~

~~B. The Educational Administrator:~~

- ~~1. Makes the well-being of students the fundamental value of all decision-making and actions.~~
- ~~2. Fulfills professional responsibilities with honesty and integrity.~~
- ~~3. Supports the principle of due process and protects the civil and human rights of all individuals.~~
- ~~4. Obeys local, state, and national laws and does not knowingly join or support organizations that advocate, directly or indirectly, the overthrow of the government.~~
- ~~5. Implements the school board's policies.~~
- ~~6. Pursues appropriate measures to correct those laws, policies, and regulations that are not consistent with sound educational goals.~~
- ~~7. Avoids using positions for personal gain through political, social, religious, economic, or other influence.~~
- ~~8. Accepts academic degrees or professional certification only from duly accredited institutions.~~
- ~~9. Maintains the standards and seeks to improve the effectiveness of the profession through research and continuing professional development.~~
- ~~10. Honors all contracts until fulfillment, release, or dissolution is mutually agreed upon by all parties to the contract.~~
- ~~11. Adheres to the Code of Ethics for School Administrators in Minnesota Rule.~~

Legal References: Minn. Stat. § 122A.14, Subd. 4 (Duties of Board of School Administrators)
Minn. Rules Part 3512.0100 (Definitions)
Minn. Rules Part 3512.5200 (Code of Ethics for School Administrators)

Cross References: None

First Reading: 10.21.2025
Second Reading: 11.13.2025
Adopted: 11.18.2025
Revised:

306 - 2 of 2

413 HARASSMENT AND VIOLENCE

I. PURPOSE

The purpose of this policy is to maintain a learning and working environment free from harassment and violence on the basis of race, color, creed, religion, national origin, sex, age, marital status, familial status, status with regard to public assistance, sexual orientation, or disability (Protected Class).

II. GENERAL STATEMENT OF POLICY

- A. The policy of the school district is to maintain a learning and working environment free from harassment and violence on the basis of Protected Class. The school district prohibits any form of harassment or violence on the basis of Protected Class. Harassment and violence of any kind towards any individual is prohibited in Duluth Public Schools.
- B. A violation of this policy occurs when any student, teacher, administrator, or other school district personnel harasses a student, teacher, administrator, or other school district personnel or group of students, teachers, administrators, or other school district personnel through conduct or communication based on a person's Protected Class, as defined by this policy. (For purposes of this policy, school district personnel include school board members, school employees, agents, volunteers, contractors, or persons subject to the supervision and control of the district.)
- C. A violation of this policy occurs when any student, teacher, administrator, or other school district personnel inflicts, threatens to inflict, or attempts to inflict violence upon any student, teacher, administrator, or other school district personnel or group of students, teachers, administrators, or other school district personnel based on a person's Protected Class.
- D. The school district will act to investigate all complaints, either formal or informal, verbal or written, of harassment or violence based on a person's Protected Class, and to discipline or take appropriate action against any student, teacher, administrator, or other school district personnel found to have violated this policy.

III. DEFINITIONS

- A. "Assault" is:
 - 1. an act done with intent to cause fear in another of immediate bodily harm or death;
 - 2. the intentional infliction of or attempt to inflict bodily harm upon another; or
 - 3. the threat to do bodily harm to another with present ability to carry out the threat.
- B. "Harassment" prohibited by this policy consists of physical or verbal conduct, including, but not limited to, electronic communications, relating to an individual's or group of individuals' race, color, creed, religion, national origin, sex, age, marital status, familial status, status with regard to public assistance, sexual orientation, including gender identity or expression, or disability, when the conduct:
 - 1. has the purpose or effect of creating an intimidating, hostile, or offensive working or academic environment;

2. has the purpose or effect of substantially or unreasonably interfering with an individual's work or academic performance; or
 3. otherwise adversely affects an individual's employment or academic opportunities.
- C. "Immediately" means as soon as possible but in no event longer than 24 hours.
- D. Protected Classifications
1. "Disability" means, with respect to an individual who
 - a. has a physical sensory or mental impairment that materially limits one or more major life activities of such individual;
 - b. has a record of such an impairment;
 - c. is regarded as having such an impairment; or
 - d. has an impairment that is episodic or in remission and would materially limit a major life activity when active.
 2. "Familial status" means the condition of one or more minors having legal status or custody with:
 - a. the minor's parent or parents or the minor's legal guardian or guardians; or
 - b. the designee of the parent or parents or guardian or guardians with the written permission of the parent or parents or guardian or guardians. Familial status also means residing with and caring for one or more individuals who lack the ability to meet essential requirements for physical health, safety, or self-care because the individual or individuals are unable to receive and evaluate information or make or communicate decisions. The protections afforded against harassment or discrimination on the basis of family status apply to any person who is pregnant or is in the process of securing legal custody of an individual who has not attained the age of majority.
 3. "Marital status" means whether a person is single, married, remarried, divorced, separated, or a surviving spouse and, in employment cases, includes protection against harassment or discrimination on the basis of the identity, situation, actions, or beliefs of a spouse or former spouse.
 4. "National origin" means the place of birth of an individual or of any of the individual's lineal ancestors.
 5. "Sex" includes, but is not limited to, pregnancy, childbirth, and disabilities related to pregnancy or childbirth.
 6. "Sexual orientation" means to whom someone is, or is perceived of as being, emotionally, physically, or sexually attracted to based on sex or gender identity. A person may be attracted to men, women, both, neither, or to people who are genderqueer, androgynous, or have other gender identities.

7. "Status with regard to public assistance" means the condition of being a recipient of federal, state, or local assistance, including medical assistance, or of being a tenant receiving federal, state, or local subsidies, including rental assistance or rent supplements.
- E. "Remedial response" means a measure to stop and correct acts of harassment or violence, prevent acts of harassment or violence from recurring, and protect, support, and intervene on behalf of a student who is the target or victim of acts of harassment or violence.
 - F. Sexual Harassment
 1. Sexual harassment includes unwelcome sexual advances, requests for sexual favors, sexually motivated physical conduct, or other verbal or physical conduct or communication of a sexual nature when:
 - a. submission to that conduct or communication is made a term or condition, either explicitly or implicitly, of obtaining employment or an education; or
 - b. submission to or rejection of that conduct or communication by an individual is used as a factor in decisions affecting that individual's employment or education; or
 - c. that conduct or communication has the purpose or effect of substantially interfering with an individual's employment or education, or creating an intimidating, hostile, or offensive employment or educational environment.
 2. Sexual harassment may include, but is not limited to:
 - a. unwelcome verbal harassment or abuse;
 - b. unwelcome pressure for sexual activity;
 - c. unwelcome, sexually motivated, or inappropriate patting, pinching, or physical contact, other than necessary restraint of student(s) by teachers, administrators, or other school district personnel to avoid physical harm to persons or property;
 - d. unwelcome sexual behavior or words, including demands for sexual favors, accompanied by implied or overt threats concerning an individual's employment or educational status;
 - e. unwelcome sexual behavior or words, including demands for sexual favors, accompanied by implied or overt promises of preferential treatment with regard to an individual's employment or educational status; or
 - f. unwelcome behavior or words directed at an individual because of sexual orientation, including gender identity or expression.

G. Sexual Violence

1. Sexual violence is a physical act of aggression or force or the threat thereof that involves the touching of another's intimate parts or forcing a person to touch any person's intimate parts. Intimate parts, as defined in Minnesota Statutes, section 609.341, includes the primary genital area, groin, inner thigh, buttocks, or breast, as well as the clothing covering these areas.
2. Sexual violence may include, but is not limited to:
 - a. touching, patting, grabbing, or pinching another person's intimate parts
 - b. coercing, forcing, or attempting to coerce or force the touching of anyone's intimate parts;
 - c. coercing, forcing, or attempting to coerce or force sexual intercourse or a sexual act on another; or
 - d. threatening to force or coerce sexual acts, including the touching of intimate parts or intercourse, on another.

H. Violence

Violence prohibited by this policy is a physical act of aggression or assault upon another or group of individuals because of, or in a manner reasonably related to an individual's Protected Class.

IV. REPORTING PROCEDURES

- A. Any person who believes he or she has been the target or victim of harassment or violence on the basis of Protected Class by a student, teacher, administrator, or other school district personnel, or any person with knowledge or belief of conduct which may constitute harassment or violence prohibited by this policy toward a student, teacher, administrator, or other school district personnel or group of students, teachers, administrators, or other school district personnel should report the alleged acts immediately to an appropriate school district official designated by this policy. A person may report conduct that may constitute harassment or violence anonymously. If you choose to report anonymously, you will not be informed once an investigation is complete. However, the school district may not rely solely on an anonymous report to determine discipline or other remedial responses.
- B. The school district encourages the reporting party or complainant to use the report form available from the principal or building supervisor of each building or available from the school district office, but oral reports shall be considered complaints as well.
- C. Nothing in this policy shall prevent any person from reporting harassment or violence directly to a school district human rights officer or to the superintendent. If the complaint involves the building report taker, the complaint shall be made or filed directly with the superintendent or the school district human rights officer by the reporting party or complainant.
- D. In Each School Building

The building principal, the principal's designee, or the building supervisor (hereinafter the "building report taker") is the person responsible for receiving oral or written reports of harassment or violence prohibited by this policy at the building level. Any adult school district personnel who receives a report of harassment or violence prohibited by this policy shall inform the building report taker immediately. If the

complaint involves the building report taker, the complaint shall be made or filed directly with the superintendent or the school district human rights officer by the reporting party or complainant. The building report taker shall ensure that this policy and its procedures, practices, consequences, and sanctions are fairly and fully implemented and shall serve as a primary contact on policy and procedural matters.

- E. A teacher, school administrator, volunteer, contractor, or other school employee shall be particularly alert to possible situations, circumstances, or events that might include acts of harassment or violence. Any such person who witnesses, observes, receives a report of, or has other knowledge or belief of conduct that may constitute harassment or violence shall make reasonable efforts to address and resolve the harassment or violence and shall inform the building report taker immediately. School district personnel who fail to inform the building report taker of conduct that may constitute harassment or violence or who fail to make reasonable efforts to address and resolve the harassment or violence in a timely manner may be subject to disciplinary action.
- F. Upon receipt of a report, the building report taker must notify the school district human rights officer immediately, without screening or investigating the report. The building report taker may request, but may not insist upon, a written complaint. A written statement of the facts alleged will be forwarded as soon as practicable by the building report taker to the human rights officer. If the report was given verbally, the building report taker shall personally reduce it to written form within 24 hours and forward it to the human rights officer. Failure to forward any harassment or violence report or complaint as provided herein may result in disciplinary action against the building report taker.
- G. In the District
The school board hereby designates Theresa Severance, Executive Director of Human Resources and Operations, theresa.severance@isd709.org as the school district human rights officer(s) to receive reports or complaints of harassment or violence prohibited by this policy. If the complaint involves a human rights officer, the complaint shall be filed directly with the superintendent.
- H. The school district shall conspicuously post the name of the human rights officer(s), including mailing addresses and telephone numbers.
- I. Submission of a good faith complaint or report of harassment or violence prohibited by this policy will not affect the complainant or reporter's future employment, grades, work assignments, or educational or work environment.
- J. Use of formal reporting forms is not mandatory.
- K. Reports of harassment or violence prohibited by this policy are classified as private educational and/or personnel data and/or confidential investigative data and will not be disclosed except as permitted by law.
- L. The school district will respect the privacy of the complainant(s), the individual(s) against whom the complaint is filed, and the witnesses as much as possible, consistent with the school district's legal obligations to investigate, to take appropriate action, and to comply with any discovery or disclosure obligations.
- M. Retaliation against a victim, good faith reporter, or a witness of violence or harassment is prohibited.
- N. False accusations or reports of violence or harassment against another person are prohibited.

- O. A person who engages in an act of violence or harassment, reprisal, retaliation, or false reporting of violence or harassment, or permits, condones, or tolerates violence or harassment shall be subject to discipline or other remedial responses for that act in accordance with the school district's policies and procedures.

Consequences for students who commit, or are a party to, prohibited acts of violence or harassment or who engage in reprisal or intentional false reporting may range from remedial responses or positive behavioral interventions up to and including suspension and/or expulsion.

Consequences for employees who permit, condone, or tolerate violence or harassment or engage in an act of reprisal or intentional false reporting of violence or harassment may result in disciplinary action up to and including termination or discharge.

Consequences for other individuals engaging in prohibited acts of violence or harassment may include, but not be limited to, exclusion from school district property and events and/or termination of services and/or contracts.

V. INVESTIGATION

- A. By authority of the school district, the human rights officer, within three (3) days of the receipt of a report or complaint alleging harassment or violence prohibited by this policy, shall undertake or authorize an investigation. The investigation may be conducted by school district officials or by a third party designated by the school district.
- B. The investigation may consist of personal interviews with the complainant, the individual(s) against whom the complaint is filed, and others who may have knowledge of the alleged incident(s) or circumstances giving rise to the complaint. The investigation may also consist of any other methods and documents deemed pertinent by the investigator.
- C. In determining whether alleged conduct constitutes a violation of this policy, the school district should consider the surrounding circumstances, the nature of the behavior, past incidents or past or continuing patterns of behavior, the relationships between the parties involved, and the context in which the alleged incidents occurred. Whether a particular action or incident constitutes a violation of this policy requires a determination based on all the facts and surrounding circumstances.
- D. In addition, the school district may take immediate steps, at its discretion, to protect the target or victim, the complainant, and students, teachers, administrators, or other school district personnel pending completion of an investigation of alleged harassment or violence prohibited by this policy.
- E. The alleged perpetrator of the act(s) of harassment or violence shall be allowed the opportunity to present a defense during the investigation or prior to the imposition of discipline or other remedial responses.
- F. The investigation will be completed as soon as practicable. The school district human rights officer shall make a written report to the superintendent upon completion of the investigation. If the complaint involves the superintendent, the report may be filed directly with the school board. The report shall include a determination of whether the allegations have been substantiated as factual and whether they appear to be violations of this policy.

VI. SCHOOL DISTRICT ACTION

- A. Upon completion of an investigation that determines a violation of this policy has occurred, the school district will take appropriate action. Such action may include, but is not limited to, warning, suspension, exclusion, expulsion, transfer, remediation, termination, or discharge. Disciplinary consequences will be sufficiently severe to try to deter violations and to appropriately discipline prohibited behavior. School district action taken for violation of this policy will be consistent with requirements of applicable collective bargaining agreements, Minnesota and federal law, and applicable school district policies and regulations.
- B. The school district is not authorized to disclose to a victim private educational or personnel data regarding an alleged perpetrator who is a student or employee of the school district. School officials will notify the targets or victims and alleged perpetrators of harassment or violence, the parent(s) or guardian(s) of targets or victims of harassment or violence and the parent(s) or guardian(s) of alleged perpetrators of harassment or violence who have been involved in a reported and confirmed harassment or violence incident of the remedial or disciplinary action taken, to the extent permitted by law.
- C. In order to prevent or respond to acts of harassment or violence committed by or directed against a child with a disability, the school district shall, where determined appropriate by the child's individualized education program (IEP) or Section 504 team, allow the child's IEP or Section 504 plan to be drafted to address the skills and proficiencies the child needs as a result of the child's disability to allow the child to respond to or not to engage in acts of harassment or violence.

VII. RETALIATION OR REPRISAL

The school district will discipline or take appropriate action against any student, teacher, administrator, or other school district personnel who commits an act of reprisal or who retaliates against any person who asserts, alleges, or makes a good faith report of alleged harassment or violence prohibited by this policy, who testifies, assists, or participates in an investigation of retaliation or alleged harassment or violence, or who testifies, assists, or participates in a proceeding or hearing relating to such harassment or violence. Retaliation includes, but is not limited to, any form of intimidation, reprisal, harassment, or intentional disparate treatment. Disciplinary consequences will be sufficiently severe to deter violations and to appropriately discipline the individual(s) who engaged in the harassment or violence. Remedial responses to the harassment or violence shall be tailored to the particular incident and nature of the conduct.

VIII. RIGHT TO ALTERNATIVE COMPLAINT PROCEDURES

These procedures do not deny the right of any individual to pursue other avenues of recourse which may include filing charges with the Minnesota Department of Human Rights or another state or federal agency, initiating civil action, or seeking redress under state criminal statutes and/or federal law.

IX. HARASSMENT OR VIOLENCE AS ABUSE

- A. Under certain circumstances, alleged harassment or violence may also be possible abuse under Minnesota law. If so, the duties of mandatory reporting under Minnesota Statutes, chapter 260E may be applicable.
- B. Nothing in this policy will prohibit the school district from taking immediate action to protect victims of alleged harassment, violence, or abuse.

X. DISSEMINATION OF POLICY AND TRAINING

- A. This policy shall be conspicuously posted throughout each school building in areas accessible to students and staff members.
- B. This policy shall be given to each school district employee and independent contractor who regularly interacts with students at the time of initial employment with the school district.
- C. This policy shall appear in the student handbook.
- D. The school district will develop a method of discussing this policy with students and employees.
- E. The school district may implement violence prevention and character development education programs to prevent and reduce policy violations. Such programs may offer instruction on character education including, but not limited to, character qualities such as attentiveness, truthfulness, respect for authority, diligence, gratefulness, self-discipline, patience, forgiveness, respect for others, peacemaking, resourcefulness, and/or sexual abuse prevention.
- F. This policy shall be reviewed at least annually for compliance with state and federal law.

Legal References: Minn. Stat. § 120B.232 (Character Development Education)
Minn. Stat. § 120B.234 (Child Sexual Abuse Prevention Education)
Minn. Stat. § 121A.03, Subd. 2 (Sexual, Religious, and Racial Harassment and Violence Policy)
Minn. Stat. § 121A.031 (School Student Bullying Policy)
Minn. Stat. Ch. 363A (Minnesota Human Rights Act)
Minn. Stat. § 609.341 (Definitions)
Minn. Stat. Ch. 260E (Reporting of Maltreatment of Minors)
20 U.S.C. §§ 1681-1688 (Title IX of the Education Amendments of 1972)
29 U.S.C. § 621 *et seq.* (Age Discrimination in Employment Act)
29 U.S.C. § 794 (Section 504 of the Rehabilitation Act of 1973)
42 U.S.C. § 1983 (Civil Action for Deprivation of Rights)
42 U.S.C. § 2000d *et seq.* (Title VI of the Civil Rights Act of 1964)
42 U.S.C. § 2000e *et seq.* (Title VII of the Civil Rights Act)
42 U.S.C. § 12101 *et seq.* (Americans with Disabilities Act)

Cross References: MSBA/MASA Model Policy 102 (Equal Educational Opportunity)
MSBA/MASA Model Policy 401 (Equal Employment Opportunity)
MSBA/MASA Model Policy 402 (Disability Nondiscrimination Policy)
MSBA/MASA Model Policy 403 (Discipline, Suspension, and Dismissal of School District Employees)
MSBA/MASA Model Policy 406 (Public and Private Personnel Data)
MSBA/MASA Model Policy 414 (Mandated Reporting of Child Neglect or Physical or Sexual Abuse)
MSBA/MASA Model Policy 415 (Mandated Reporting of Maltreatment of Vulnerable Adults)
MSBA/MASA Model Policy 506 (Student Discipline)
MSBA/MASA Model Policy 514 (Bullying Prohibition Policy)
MSBA/MASA Model Policy 515 (Protection and Privacy of Pupil Records)
MSBA/MASA Model Policy 521 (Student Disability Nondiscrimination)
MSBA/MASA Model Policy 522 (Title IX Sex Nondiscrimination, Grievance Procedures and Process)
MSBA/MASA Model Policy 524 (Internet Acceptable Use and Safety Policy)
MSBA/MASA Model Policy 525 (Violence Prevention)

MSBA/MASA Model Policy 526 (Hazing Prohibition)
MSBA/MASA Model Policy 528 (Student Parental, Family, and Marital Status
Nondiscrimination)

Replacing: Policy 4015
First Reading: 05-19-2015
Adopted: 06-16-2015
04-19-2016 ISD 709 (*Renumbering only*)
First Reading: 07-19-2016
Second Reading: 08-16-2016
First Reading: 04-15-2025
Second Reading: 05-13-2025
Adopted: 05-20-2025
Reviewed:

511 FUNDRAISING

I. PURPOSE

The purpose of this policy is to address fundraising efforts by students and employees of the Duluth Public Schools.

II. GENERAL STATEMENT OF POLICY

The school board recognizes a desire and a need by some student organizations for fundraising. The school board also recognizes a need for some constraint to prevent fundraising activities from becoming too numerous and overly demanding on employees, students, and the general public. All fundraising activities must be approved by both administration and the School Board before they begin.

III. DEFINITION

A. Fundraising examples include, but are not limited to, grocery bagging for tips, gift and discount card sales, book fairs, food sales, plant sales, Box Tops for Education, and crowdfunding activities. Any activity for the purpose of raising funds for a club, team, or school is considered a fundraiser.

III. RESPONSIBILITY

- A. The building administrators shall be responsible for developing recommendations to the superintendent that will result in a level of activity deemed acceptable by employees, parents, and students. Fundraising must be conducted in a manner that will not result in embarrassment on the part of individual students, employees, or the school.
- B. All fundraising activities must be approved, in advance, by both the administration and school board. Participation in nonapproved activities shall be considered a violation of school district policy.
- C. The superintendent shall be responsible for providing coordination of student fundraising throughout the school district as deemed appropriate.
- D. The school district expects all students who participate in approved fundraising activities to represent the school, the student organization, and the community in a responsible manner. All rules pertaining to student conduct and student discipline extend to student fundraising activities.
- E. The school district expects all employees who plan, supervise, coordinate, or participate in student fundraising activities to act in the best interests of the students and to represent the school, the student organization, and the community in a responsible manner.
- F. The building administrators shall be responsible for complying with the District's Wellness Policy (Policy 533).

- G. When a fundraising event is taking place at a district site, the Facility Use Coordinator must be contacted.

IV. MONTHLY ANNUAL REPORT

All fundraisers The superintendent shall be reported to the school board, at least annually, on a monthly basis and will describe the nature and scope of student fundraising activities approved pursuant to this policy.

Legal References: Minn. Stat. § 120A.20 (~~Age Limitations; Pupils Admission to Public School~~)
Minn. Stat. § 123B.09, Subd. 8 (~~Duties Boards of Independent School Districts~~)
Minn. Stat. § 123B.36 (Authorized Fees)

Cross References: MSBA/MASA Model Policy 506 (Student Discipline)
MSBA/MASA Model Policy 713 (Student Activity Accounting)

Other References: 2019 UFARS Chapter 14 Student Activity Accounting

New Policy
Replacing: 1050
First Reading: 11-19-2019
Adopted: 12-17-2019
Revised:

606 TEXTBOOKS AND INSTRUCTIONAL MATERIALS

I. PURPOSE

The purpose of this policy is to provide direction for selection of textbooks and instructional materials.

II. GENERAL STATEMENT OF POLICY

The school board recognizes that selection of textbooks and instructional materials is a vital component of the school district's curriculum. The school board also recognizes that it has the authority to make final decisions on selection of all textbooks and instructional materials.

III. RESPONSIBILITY OF SELECTION

- A. While the school board retains its authority to make final decisions on the selection of textbooks and instructional materials, the school board recognizes the expertise of the professional staff and the vital need of such staff to be primarily involved in the recommendation of textbooks and instructional materials. Accordingly, the school board delegates to the superintendent the responsibility to direct the professional staff in formulating recommendations to the school board on textbooks and other instructional materials.
- B. In reviewing textbooks and instructional materials during the selection process, the professional staff shall select materials that:
 - 1. support the goals and objectives of the education programs;
 - 2. consider the needs, age, and maturity of students;
 - 3. foster respect and appreciation for cultural diversity and varied opinion;
 - 4. fit within the constraints of the school district budget;
 - 5. are in the English language. Another language may be used, pursuant to Minnesota Statutes, 124D.59 to 124D.61;
 - 6. permit grade-level instruction for students to read and study America's founding documents, including documents that contributed to the foundation or maintenance of America's representative form of limited government, the Bill of Rights, our free-market economic system, and patriotism; and
 - 7. do not censor or restrain instruction in American or Minnesota state history or heritage based on religious references in original source documents, writings, speeches, proclamations, or records.
- C. The superintendent shall be responsible for developing procedures and guidelines to establish an orderly process for the review and recommendation of textbooks and other instructional materials by the professional staff. Such procedures and guidelines shall provide opportunity for input and consideration of the views of students, parents, and other interested members of the school district community. This procedure shall be coordinated with the school district's curriculum development effort and may utilize advisory committees.

IV. SELECTION OF TEXTBOOKS AND OTHER INSTRUCTIONAL MATERIALS

- A. The superintendent shall be responsible for keeping the school board informed of progress on the part of staff and others involved in the textbook and other instructional materials review and selection process.
- B. The superintendent shall present a recommendation to the school board on the selection of textbooks and other instructional materials after completion of the review process as outlined in this policy.

V. RECONSIDERATION OF TEXTBOOKS OR OTHER INSTRUCTIONAL MATERIALS

- A. The school board recognizes differences of opinion on the part of some members of the school district community relating to certain areas of the instruction program. Interested persons may request an opportunity to review materials and submit a request for reconsideration of the use of certain textbooks or instructional materials. Access to the materials in question shall not be restricted until the procedures listed below have been fully completed and a decision to remove or restrict the materials has been made.

B. Formal Request for Reconsideration of a Textbook or Other Instructional Resource

- 1. A Formal Request for Reconsideration of a textbook or other instructional resource is initiated upon submission of a completed [Formal Request for Reconsideration of Instructional Resource or Specific Library Collection Material](#) form. The form must be completed in its entirety for each resource that is subject to a request for reconsideration and submitted to the school principal. The principal shall notify the superintendent or the superintendent's designee of receipt of a completed Formal Request form.

The district will respond to Formal Request for Reconsideration within 60 school contract days. One challenge will be addressed by the committee at a time.

If specific instructional material is the subject of a Formal Request for Reconsideration and a final decision is made to retain the specific instructional material, then the specific instructional material shall not be subject to additional requests for reconsideration for three years following the date of final resolution of the initial Formal Request for Reconsideration.

- 2. The Superintendent or the superintendent's designee shall appoint an Instructional Materials Review Committee (Review Committee) upon receipt of a Formal Request for Reconsideration. This committee shall include:
 - a. One member of the school district administration
 - b. One principal
 - c. Two teachers of the discipline named in the complaint (one of which shall be the content area lead teacher)
 - d. Two members of the school district community with no direct connection with the request for reconsideration
 - e. Two student representatives (as appropriate to the specific request).
- 3. The Review Committee chair shall establish a date upon which it will discuss

the request and whether the specific instructional material conforms to the selection criteria set forth in this policy.

4. The Review Committee

- a. may consult individuals, organizations, and other resources with relevant professional knowledge on instructional material;
- b. shall examine the specific instructional material's area of concern;
- c. shall examine the specific instructional material as to its conformance with the criteria for selection of instructional materials; and
- d. shall submit a written report to the superintendent or the superintendent's designee containing the Review Committee's decision on whether to retain, to remove, or to take other action regarding the specific instructional material.

5. The superintendent or the superintendent's designee shall inform the requestor and the school board of the Review Committee's decision.

6. The requestor shall have the right to appeal the decision of the Review Committee to the superintendent and the school board.

- C. All instructional materials, including teacher's manuals, films, tapes, or other supplementary material which will be used in connection with any survey, analysis, or evaluation as part of any applicable program shall be available for inspection by the parents or guardians of the students.

Legal References: Minn. Stat. § 120A.22, Subd. 9 (Compulsory Instruction ~~—Knowledge and Skills~~)
Minn. Stat. § 120B.235 (American Heritage Education)
Minn. Stat. § 123B.02, Subd. 2 (General Powers of Independent School Districts)
Minn. Stat. § 123B.09, Subd. 8 (School Board Responsibilities)
Minn. Stat. § 124D.59-124D.61 (Education for English Learners Act)
Minn. Stat. § 127A.10 (State Officials and School Board Members to be Disinterested; Penalty)
20 U.S.C. 1232h(a) (Protection of Pupil Rights)
Hazelwood Sch. Dist. v. Kuhlmeier, 484 U.S. 260 (1988)
Pratt v. Independent Sch. Dist. No. 831, 670 F.2d 771 (8th Cir. 1982)

Cross References: MSBA/MASA Model Policy 603 (Curriculum Development)
MSBA/MASA Model Policy 604 (Instructional Curriculum)

Replaces: Policies 6030, 6035 & 6040
First Reading: 12.19.2023
Second Reading: 01.23.2024
Adopted: 01.23.2024
Reviewed: 01.28.2025
Revised:

701 ESTABLISHMENT AND ADOPTION OF SCHOOL DISTRICT BUDGET

I. PURPOSE

The purpose of this policy is to establish lines of authority and procedures for the establishment of the school district's revenue and expenditure budgets.

II. GENERAL STATEMENT OF POLICY

The policy of the school district is to establish its revenue and expenditure budgets in accordance with the applicable provisions of law. Budget planning is an integral part of program planning so that the annual budget will effectively express and implement school board goals, and the mission, values and priorities of the school district.

III. REQUIREMENTS

- A. The superintendent or such other school official as designated by the superintendent or the school board, shall each year prepare preliminary revenue and expenditure budgets for review in April, by the school board or its designated committee or committees. ~~The preliminary budgets shall be accompanied by such written commentary as may be necessary for them to be clearly understood by the members of the school board and the public. The school board shall review the projected revenues and expenditures for the school district for the next fiscal year, and make such adjustments in the expenditure budget as necessary to carry out the education program within the revenues projected.~~ When projected expenditures exceed projected revenues, the school board may consider use of an available fund balance, if one exists.
- B. ~~The school district must maintain separate accounts to identify revenues and expenditures for each building.~~ Expenditures shall be reported in compliance with Minnesota Statutes, § section 123B.76.
- C. Prior to July 1 of each year, the school board shall must approve and adopt its initial revenue and expenditure budgets for the next school year. The ~~adopted expenditure budget document so adopted must shall~~ be considered ~~the school board's an expenditure authorizing or appropriations document authorization for that school year.~~ No funds may shall be expended for any purpose in any school year prior to the adoption of the budget document which authorizes that expenditure for that year, or prior to the adoption of an amendment to that budget document by the school board to authorize that expenditure for that year.
- D. Each year, the school district shall must publish its adopted revenue and expenditure budgets for the current year, the actual revenues, expenditures, and fund balances for the prior year, and the projected fund balances for the current year in the form prescribed by the Commissioner of the Minnesota Department of Education (Commissioner) within one week of the acceptance of the final audit by the school board, or November 30, whichever is earlier. A statement shall must be included in the publication that the complete budget in detail may be inspected by any resident of the school district upon request to the superintendent. ~~A summary of this information and the address of the school district's official website where the information can be found must be published in a newspaper of general circulation in the school district.~~ At the same time as this publication, the school district shall publish the other information required by Minnesota Statutes, § section 123B.10.

- E. At the public hearing on the adoption of the school district's proposed property tax levy, the school board shall review its current budget and the proposed property taxes payable in the following calendar year.
- F. The school district must also post the materials specified in Paragraph III.D. above **in a conspicuous place** on the school district's official website, including a link to the school district's school report card on the Minnesota Department of Education's website. ~~and publish a summary of information and the address of the school district's website where the information can be found in a qualified newspaper of general circulation in the district.~~

IV. IMPLEMENTATION

- A. The school board places the responsibility for administering the adopted budget with the superintendent. The superintendent may delegate duties related thereto to other school officials, but maintains the ultimate responsibility for this function.
- B. The program-oriented budgeting system will be supported by a program-oriented accounting structure organized and operated on a fund basis as provided for in Minnesota statutes through the Uniform Financial Accounting and Reporting Standards for Minnesota School Districts (UFARS).
- C. The superintendent or the superintendent's designee is authorized to make payments of claims or salaries authorized by the adopted or amended budget prior to school board approval.
- D. Supplies and capital equipment can be ordered prior to budget adoption only by authority of the school board. If additional personnel are provided in the proposed budget, actual hiring may not occur until the budget is adopted unless otherwise approved by the school board. Other funds to be expended in a subsequent school year may not be encumbered prior to budget adoption unless specifically approved by the school board.
- E. The school district shall make such reports to the Commissioner as required relating to initial allocations of revenue, reallocations of revenue, and expenditures of funds.

Legal References: Minn. Stat. § 123B.10 (Publication of Financial Information)
Minn. Stat. § 123B.76 (Expenditures; Reporting)
Minn. Stat. § 123B.77 (Accounting, Budgeting, and Reporting Requirements)

Cross References: MSBA/MASA Model Policy 701.1 (Modification of School District Budget)
MSBA/MASA Model Policy 702 (Accounting)
~~MSBA Service Manual, Chapter 7, Education Funding~~

New Policy
Replacing: 3005, 3015, 3100, 3105, 3110
First Reading: 08-21-2018
Adopted: 09-18-2018
Revised:

701.1 MODIFICATION OF SCHOOL DISTRICT BUDGET

I. PURPOSE

The purpose of this policy is to establish procedures for the modification of the school district's adopted revenue and expenditure budgets.

II. GENERAL STATEMENT OF POLICY

The policy of this school district is to modify its revenue and expenditure budgets in accordance with the applicable provisions of law.

III. REQUIREMENT

- A. The school district's adopted expenditure budget shall be considered the school board's expenditure authorization for that school year.
- B. If revisions or modifications in the adopted expenditure budget are determined to be advisable by the administration, the superintendent shall recommend the proposed changes to the school board. The proposed changes shall be accompanied by sufficient and appropriate background information on the revenue and policy issues involved to allow the school board to make an informed decision. A school board member may also propose modifications on that board member's own motion, provided, however, the school board member is encouraged to review the proposed modifications with the superintendent prior to their being proposed so that the administration may prepare necessary background materials for the school board prior to its consideration of those proposed modifications.
- C. If sufficient funds are not included in the expenditure budget in a particular fund to allow the proposed expenditure, funds for this purpose may not be expended from that fund prior to the adoption of an expenditure budget amendment by the school board to authorize that expenditure for that school year. An amended expenditure shall not exceed the projected revenues available for that purpose in that fund.
- D. The school district's revenue budget shall be amended from time to time during a fiscal year to reflect updated or revised revenue estimates. The superintendent shall make recommendations to the school board for appropriate revisions. If necessary, the school board shall also make necessary revisions in the expenditure budget if it appears that expenditures would otherwise exceed revenues and fund balances in a fund.

Legal References: Minn. Stat. § 123B.77 (Accounting, Budgeting, and Reporting Requirement)

Cross References: MSBA/MASA Model Policy 701 (Establishment and Adoption of School District Budget)

~~MSBA Service Manual, Chapter 7, Education Funding~~

New Policy
Replacing: 3010
First Reading: 08-21-2018
Adopted: 09-18-2018
Revised:

Name of Person Filing Complaint (Complainant): _____

Address: _____

Telephone: _____ (Home) _____ (School/Work Location)

Status of Person Filing the Complaint: Student Employee Parent Other _____ (Specify)

Type of Complaint: Sexual General Protected Group (select group from list below)

Protected Group: Race Color Creed Religion National Origin Sex Age Marital Status
 Disability Public Assistance Sexual Orientation Gender Identity/Expression Other Protected Group

Name of Person You Are Reporting (Respondent): _____

Status of Person You Are Reporting: Student Employee Parent Other _____ (Specify)

Statement of Complaint (Include type of harassment/violence, who was involved in the specific incidents in which it occurred, names of witnesses, etc.): _____

(Continue on reverse side or attach pages as needed.)

I UNDERSTAND THAT IN ACCORDANCE WITH DISTRICT POLICY #413, INDEPENDENT SCHOOL DISTRICT 709 WILL ADDRESS THIS COMPLAINT.

Signature of Complainant: _____ Date: _____

Signature of Person Receiving The Complaint: _____ Date Received: _____

Printed Name of Person Receiving The Complaint: _____

Name of Building Administrator (if different from person receiving initial complaint): _____

Original to Human Resources Date Distributed: _____
(Human Resources will distribute a copy to the District's Climate Coordinator)

Copies Distributed To: Building Administrator Date Distributed: _____

(To be completed by Human Resources)
REPORT NUMBER: Year: _____ Building Code: _____ Number In Sequence By Year: _____

511R FUNDRAISING

The following information will help you coordinate your fundraising efforts and includes guidelines and procedures for District staff when wanting to initiate a fundraiser.

Note: Fundraising may not begin until approved by completing the following steps.

I. DEFINITIONS

There are two sections below based on the type of fundraising you want to do:

General fundraising (examples below, this is not an all-inclusive list)

- o Box Tops
- o Sale of coupon books
- o Bagging groceries
- o Percentage of sales at local businesses
- o Sale of wreaths, wrapping paper, food

Crowdfunding

- o The practice of funding a project or idea by raising small amounts of money from a large number of people, typically via the internet. The following is a list of approved crowdfunding sites:
 - Adopt-A-Classroom
 - ClassWish
 - DonorsChoose
 - GoFundMe
 - PledgeCents
 - TeacherLists
 - Boost My School

II. PROCEDURES

General fundraising

1. Building staff must complete the District Fundraising Google form indicating that there is an active fundraising request. General fundraising includes activities like Box Tops, ~~school pictures~~, sale of coupon books, bagging groceries, sale of clothing, food, etc.
 - Fundraisers completed by an outside organization (not the school itself) such as a PTA, parent group or school foundation are not reported to the Board.
 - If any monies from these fundraisers are donated to a school, they would be reported as a donation by the school's clerical staff using the District Google Donation form located on the [Business Services intranet page](#).
 - District Fundraising Google form located on the [Business Services intranet page](#).
 - Answer all the questions including staff person coordinating the fundraising, building and/or program, amount of request, description of use of funds, estimated gross and net revenues and start and end date of fundraising.
 - Ignore the crowdfunding questions as they do not apply to general fundraising (follow instructions on Google form).

- If the fundraising effort results in non-monetary items (supplies, equipment, etc.), the items must be sent to the District and become property of the District.
 - All monetary donations must be recorded by the District and deposited into a District account. A check should be requested to be mailed to the school in the District's name, not an individual person. The District will ensure appropriate accounting. Items cannot be purchased until the donation is received by the District and approved through the District finance department.
2. Business Services staff will compile all fundraiser information on a monthly basis and report it to the School Board for approval. The School Board currently meets on a monthly basis so plan accordingly.
 3. After the School Board meeting, Business Services staff will notify the fundraiser coordinators if their fundraising requests were approved or denied by the School Board.

Crowdfunding

1. Building staff must complete the District Fundraising Google form indicating that there is an active crowdfunding request. All requests must follow the Approval Criteria Guidelines. You will be asked to verify that you discussed with the appropriate parties and that they approve of your request:
 - Requests that involve **athletics** must have Athletic Director approval before moving to final approval.
 - Requests that involve **technology** must have Technology Department approval before moving to final approval. Examples include hardware such as Chromebooks, laptops, and software.
 - Requests that involve **curriculum**, such as workbooks, textbooks, or learning materials must have Curriculum Director approval before moving to final approval.
 - Requests that involve **facility** considerations, such as electrical, plumbing, or construction must have Facilities Manager approval before moving to final approval.
- ~~2. Once initial approvals occurs (step #1 above), Business Services will forward crowdfunding applications for final approval by District Cabinet. The District Cabinet meets every two weeks so plan accordingly.~~
 - ~~• District Cabinet will confirm data and approvals from appropriate directors.~~
 - ~~• District Cabinet will review Approval Criteria Guidelines to determine final approval.~~
 - ~~• Business Services will notify building administration or program directors of application status.~~
- 32.** Following notification of final approval, the staff member can create the crowdfunding page through one of the District approved crowdfunding sites. **The following is a list of approved crowdfunding sites:**
 - Adopt-A-Classroom
 - ClassWish

- DonorsChoose
 - GoFundMe
 - PledgeCents
 - TeacherLists
 - **Boost My School**
- Staff should be aware that some sites may retain a portion/percentage of the donations.
 - Staff should consider that if a specific goal is reached and there is no alternate designation for use of funds, any additional funds received would be returned to the donors.
 - If the crowdfunding effort results in non-monetary items (supplies, equipment, etc.), the items must be sent to the District and become property of the District.
 - No purchases can be made prior to successfully reaching the fundraising goal or the end of the crowdfunding campaign.
 - The District will not fund the remainder of projects receiving partial funding from donors.
 - All monetary donations must be recorded by the District and deposited into a District account. A check should be requested to be mailed to the school in the District's name, not an individual person. The District will ensure appropriate accounting. Items cannot be purchased until the donation is received by the District and approved through the District finance department.
 - The Business Office must be notified of any unspent funds and will determine the appropriate way to spend or return the unused funds.

III. APPROVAL CRITERIA GUIDELINES FOR ALL FUNDRAISING

- Proposals that support the curriculum must be standards-based.
- The proposal must not conflict with the current and/or planned curriculum and instruction activities set forth by the District.
- Proposals must support district priorities.
- Proposals may not request materials that could be substituted by similar materials that are already supplied by the District or could be supplied by the District.
- Proposals may not start a program that would require the continued use of materials or funding beyond what is obtained through the proposal.
- The proposal cannot result in demands on staff not involved in the proposal.
- The proposal cannot request athletic equipment in conflict with the athletic programs of the District.
- The proposal must not cast a negative light on the District or any of its programs or employees.
- Campaigns cannot benefit individuals.

- Proposals must follow District policy, including the Wellness Policy.
- Crowdfunding campaigns cannot be contingent on additional District spending or require matching funds from the District or other organization.
- Crowdfunding campaigns may not raise money to be used by outside groups or vendors such as booster clubs, PTA/PTO, scholarships, or foundations.
- Crowdfunding campaigns cannot contain language that suggests or states that an item for which the donations are being sought are required for or integral to a student’s special education program, necessary for a student to achieve their IEP goals, or necessary to ensure participation of a student of students with disabilities in school or any program offered by the District.

NOTE: The District will take into account the volume of requests as well as the above criteria and reserve the right to limit the number of requests approved.

IV. OTHER CONSIDERATIONS

- Under the Family Educational Rights and Privacy Act (FERPA), the publication of student images (or names) is not authorized except as to specified permitted categories of “directory information,” and even then for specific purposes. Even if directory information is used properly, parents have a right to opt their children out. ONLY PHOTOS OF UNIDENTIFIABLE CHILDREN (ex., the backs of heads) may be used on your crowdfunding application page.
- Administrators will verify that statements regarding special education programs are consistent with Free Appropriate Public Education (FAPE), Individuals with Disabilities Act (IDEA), and Health Insurance Portability and Accountability Act (HIPPA).
- All items/materials obtained through District approved crowdfunding are the property of the District. While preference is given for the items/materials to be used and maintained by the employee who originally obtained them through crowdfunding, the District reserves the right to transfer such items/materials to another classroom and/or teacher, where necessary.

Questions on Criteria or Eligibility should be sent to the District Finance Manager.

Questions on forms and submissions should be sent to Business Services.

Reviewed: 01-21-2020
Revised:

HR / Business Services Committee

Duluth Public Schools, ISD 709

Agenda

Monday, May 11, 2026

District Services Center

709 Portia Johnson Dr.

Duluth, MN 55811

4:30 PM

1. <u>Guest Presentations for this Meeting - 2026 LTFM Summer Project Update (ICS)</u>	2
2. <u>Department Reports</u>	
A. Human Resources	
1) HR Monthly Department Summary Report	11
B. Business Services	
1) Enrollment Report	13
2) Child Nutrition Department Report	18
3) Facilities Department Report	19
4) Health & Safety Report	20
5) Technology Department Report	21
6) Transportation Department Report	22
3. <u>Recommended Resolutions</u>	
A. B-5-26-4165 - Acceptance of Donations to Duluth Public Schools	23
B. B-5-26-4166 - Acceptance of Grant Awards to Duluth Public Schools	28
4. <u>Consent Agenda</u>	
A. HR Staffing Report	29
B. Finances	
1) Financial Report	30
2) Fundraisers	31
C. Bids, RFPs, and Quotes - None	
D. Contracts, Change Orders and Leases	
1) Change Order — Lakewood Elementary Boiler Replacement (A.G. O'Brien Plumbing and Heating Co.)	32
2) Contract — Duluth Public Schools 2025 LTFM Phase 1 Projects (Amendment)	38
5. <u>Miscellaneous Informational Items (no action required)</u>	
A. District Properties Update	41
B. Expenditure Contracts	44
C. No Cost Contracts	201
D. Revenue Contracts	221
E. Grant Applications	228
F. Change Orders Signed	229



2025 LTFM Projects

May 11, 2026



DULUTH PUBLIC SCHOOLS

Agenda

- Project Summary
- Project Update
- Schedule
- Budget

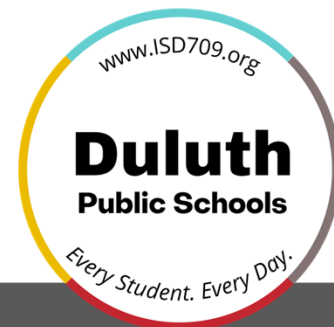

Project Summary

Winter 2026

- Lowell Elementary Lighting Replacement
- Lincoln Lighting Replacement

Summer 2026

- Lakewood Elementary Boiler Replacement
- Stowe Elementary Roofing Replacement

Summer 2027

- Denfeld High School HVAC and Controls
- Lincoln Park Middle School HVAC and Controls

Summer 2028

- East High School HVAC and Controls
- Ordean East Middle School HVAC and Controls



Project Updates

Construction Progress

- Lincoln Park Middle School Lighting Replacement
 - Project is 86% complete
 - Lighting Controls, misc. lighting and exterior lighting remain
- Lowell Elementary Lighting Replacement
 - Project is 80% complete
 - Misc. interior lighting and exterior lighting remain

Pre-Construction

- Lakewood Boiler Plant Replacement
 - Contractor & material procurement are in progress
- Stowe Roofing Replacement
 - Work scheduled to start in June
- Denfeld & Lincoln HVAC and Controls Projects
 - Both projects are in the Schematic Design phase
 - The work is planned for summer of 2027

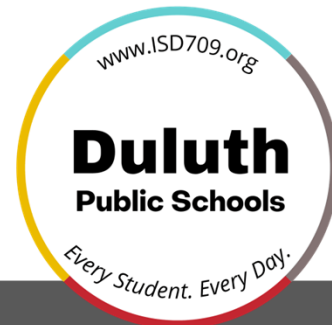

Construction Progress Lincoln Middle



Construction Progress Lowell Elementary

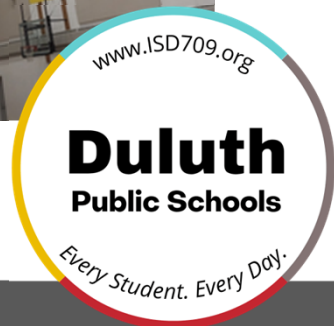

Project Budget



Duluth Public Schools

2025 Referendum
ICS Project # TBD

Date Printed 5/8/2026

OVERALL PROJECT SUMMARY

	ORIGINAL BUDGET	ADJUSTMENTS	REVISED BUDGET WITH ADJUSTMENTS	COST TO DATE	PENDING COSTS / ADJUSTMENTS	BUDGETED COST TO COMPLETE
FUNDING:						
1 FUNDING SOURCE(S)						
1.01 2025 LTFM	\$ 38,660,200	\$ -	\$ 38,660,200	\$ -	\$ -	\$ 38,660,200
TOTAL REVENUE:	\$ 38,660,200	\$ -	\$ 38,660,200	\$ -	\$ -	\$ 38,660,200
COSTS:						
2 PERMITS / OWNER COSTS / OFF SITE COSTS						
2.03 Building Permit / Plan Review	\$ 200,000	\$ -	\$ 200,000	\$ 1,881	\$ -	\$ 198,119
SUBTOTAL:	\$ 200,000	\$ -	\$ 200,000	\$ 1,881	\$ -	\$ 198,119
3 FEES / SERVICES / BUDGETS						
3.01 Program Management Fees	\$ 4,271,200	\$ -	\$ 4,271,200	\$ 1,020,200	\$ 243,200	\$ 3,007,800
3.02 Program Management Reimbursable	\$ 250,000	\$ -	\$ 250,000	\$ -	\$ -	\$ 250,000
3.03 Construction Phase Site Services	\$ 980,000	\$ -	\$ 980,000	\$ -	\$ -	\$ 980,000
3.04 Site Surveys	\$ 40,000	\$ -	\$ 40,000	\$ -	\$ -	\$ 40,000
3.05 Soil Investigation	\$ 40,000	\$ -	\$ 40,000	\$ -	\$ -	\$ 40,000
3.06 Construction Testing	\$ 150,000	\$ -	\$ 150,000	\$ -	\$ -	\$ 150,000
3.07 Bond Finance/Issuance Costs	\$ 450,000	\$ -	\$ 450,000	\$ -	\$ -	\$ 450,000
3.08 Insurance - Builders Risk	\$ 65,000	\$ -	\$ 65,000	\$ -	\$ -	\$ 65,000
3.09 Legal, Etc.	\$ 50,000	\$ -	\$ 50,000	\$ -	\$ -	\$ 50,000
3.10 Moving / Relocation / Transportation Costs	\$ 150,000	\$ -	\$ 150,000	\$ -	\$ -	\$ 150,000
3.11 Other District Project Expenses	\$ 100,000	\$ -	\$ 100,000	\$ -	\$ -	\$ 100,000
SUBTOTAL:	\$ 6,546,200	\$ -	\$ 6,546,200	\$ 1,020,200	\$ 243,200	\$ 5,282,800
4 FURNITURE / EQUIPMENT / TECHNOLOGY						
SUBTOTAL:	\$ -	\$ -	\$ -	\$ -	\$ -	\$ -
5 CONSTRUCTION COSTS						
5.01 Re-Cx Solutions	\$ 1,350,000	\$ -	\$ 1,350,000	\$ -	\$ (243,200)	\$ 1,593,200
5.02 Lakewood Elementary Boiler Replacement	\$ 650,000	\$ 279,515	\$ 929,515	\$ -	\$ -	\$ 929,515
5.03 Stowe Elementary Roof Replacement	\$ 3,484,090	\$ -	\$ 3,484,090	\$ -	\$ -	\$ 3,484,090
5.04 Lincoln Park Lighting Updates	\$ 1,800,000	\$ (844,800)	\$ 955,200	\$ 788,678	\$ -	\$ 166,521
5.05 Lowell Elementary School Lighting Updates	\$ 600,000	\$ (55,545)	\$ 544,455	\$ 413,769	\$ -	\$ 130,686
5.06 Denfeld High School	\$ 7,150,000	\$ -	\$ 7,150,000	\$ -	\$ -	\$ 7,150,000
5.07 Lincoln Park Middle School	\$ 800,000	\$ -	\$ 800,000	\$ -	\$ -	\$ 800,000
5.08 East High School	\$ 5,000,000	\$ -	\$ 5,000,000	\$ -	\$ -	\$ 5,000,000
5.09 Ordean East Middle School	\$ 5,100,000	\$ -	\$ 5,100,000	\$ -	\$ -	\$ 5,100,000
5.10 Roofing & Misc. Repair	\$ 3,915,910	\$ 633,676	\$ 4,549,586	\$ -	\$ -	\$ 4,549,586
5.11 General Conditions Allowance	\$ 550,000	\$ -	\$ 550,000	\$ -	\$ -	\$ 550,000
SUBTOTAL:	\$ 30,400,000	\$ 12,845	\$ 30,412,845	\$ 1,202,447	\$ (243,200)	\$ 29,453,598
6 CONSTRUCTION CONTINGENCY						
6.01 Construction Contingency	\$ 1,500,000	\$ (12,845)	\$ 1,487,155	\$ -	\$ -	\$ 1,487,155
SUBTOTAL:	\$ 1,500,000	\$ (12,845)	\$ 1,487,155	\$ -	\$ -	\$ 1,487,155
TOTAL COSTS:	\$ 38,646,200	\$ (0)	\$ 38,646,200	\$ 2,224,528	\$ -	\$ 36,421,672
OVERALL PROJECT BALANCE:	\$ 14,000					

Questions?



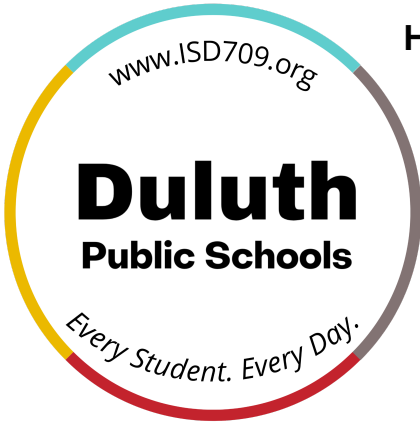

Human Resources Report for May 2026 School Board Meeting Highlighting April 2026 Activities

Department: Human Resources

HR|Business Services Committee: 05.11.2026

Regular Board Meeting: 05.19.2026

Report Prepared By: Steven Johnson

Manager’s Minutes:

- We continue to meet with unions and employees regarding the displacements.
- Posting for our Executive Director of Business, Finance and Operations.
- Posting for an American Indian Coordinator.
- Para mentors have been identified for each site and we are working to begin the mentorship program. These same mentors will be in place again for Semester 1 of the 26-27 SY. Starting semester 2, we will reach out to Principals for their next pick.

What We’re Working On:

- Open Enrollment for health insurance is open from 05/01/2026 through 05/15/2026. 33 members have made changes so far. Benefits is working on processing enrollments in Skyward.
- 24 pending MN Paid leave requests still in review with the state.

Upcoming Changes/Improvements to the Department:

- Working on skyward training for the department and changing some of the day to day duties in our office with skyward.

Staffing Report:

- | | |
|------------------------------|-------------------------------|
| • Certified Appointments -4 | Non-Certified Appointments -8 |
| • Certified Leaves -0 | Non-Certified Leaves - 0 |
| • Certified Retirements -0 | Non-Certified Retirements - 4 |
| • Certified Resignations - 3 | Non-Certified Resignations-2 |

Open Positions:

Certified:

Teachers (17)
Special Education (12)
High School (2)
Middle School (1)
Duluth Adult Education (1)
Summer School (1)

Non-Certified:

Administrative (2)
Elementary Principal (1)
American Indian Coordinator (1)
 Child Nutrition (6)
 Maintenance (7)
Second Shift Engineer I (3)
Master Electrician (1)

Second Shift Engineer II (1)

Custodian I/II/III (2)

Paraprofessionals (18)

Certified/Pre-Certified Educational Sign Language Interpreter (4)

Instructional Para (1)

Sign Language Facilitator (1)

SpEd Building Wide Para (2)

SpEd Program Para LTS (8)

SpEd Student Specific (2)

2025-2026	Total	Total	K	1	2	3	4	5	6	7	8	9	10	11	12	
School	Enroll	Gr 1-5														
Congdon Park 435	489.67	415.00	74.67	78.00	83.00	84.00	80.00	90.00	0.00	0.00	0.00	0.00	0.00	0.00	0.00	
Homecroft 475	460.00	372.00	88.00	75.00	69.00	72.00	81.00	75.00	0.00	0.00	0.00	0.00	0.00	0.00	0.00	
Lakewood 500	244.00	206.00	38.00	39.00	34.00	42.00	45.00	46.00	0.00	0.00	0.00	0.00	0.00	0.00	0.00	
Lester Park 510	519.00	429.00	90.00	74.00	83.00	98.00	81.00	93.00	0.00	0.00	0.00	0.00	0.00	0.00	0.00	
Lowell 520	313.00	270.00	43.00	60.00	53.00	48.00	60.00	49.00	0.00	0.00	0.00	0.00	0.00	0.00	0.00	
Lowell Sp Immersion 521	183.00	147.00	36.00	38.00	26.00	29.00	26.00	28.00	0.00	0.00	0.00	0.00	0.00	0.00	0.00	
MacArthur 525	253.00	213.00	40.00	39.00	43.00	41.00	47.00	43.00	0.00	0.00	0.00	0.00	0.00	0.00	0.00	
Myers Wilkins 540	454.00	376.00	78.00	85.00	74.00	70.00	80.00	67.00	0.00	0.00	0.00	0.00	0.00	0.00	0.00	
Piedmont 550	402.00	326.00	76.00	67.00	74.00	62.00	62.00	61.00	0.00	0.00	0.00	0.00	0.00	0.00	0.00	
Stowe 565	247.00	207.00	40.00	35.00	50.00	45.00	36.00	41.00	0.00	0.00	0.00	0.00	0.00	0.00	0.00	
Lincoln Middle 225	680.86	0.00	0.00	0.00	0.00	0.00	0.00	0.00	220.00	233.00	227.86	0.00	0.00	0.00	0.00	
Ordean East Middle 335	1120.34	0.00	0.00	0.00	0.00	0.00	0.00	0.00	383.00	357.00	380.34	0.00	0.00	0.00	0.00	
AE Online 650	173.93											0.28	17.07	58.96	57.61	40.01
Denfeld 215	917.47											0.00	238.15	235.22	214.03	230.07
East 220	1365.05											0.00	374.07	355.68	322.79	312.51
Merritt Creek Academy 81	89.00	34.00	3.00	6.00	4.00	6.00	12.00	6.00	6.00	16.00	10.00	8.00	6.00	6.00	0.00	
ALC 611	78.00	0.00	0.00	0.00	0.00	0.00	0.00	0.00	0.00	0.00	0.00	0.00	14.00	38.00	26.00	
Chester Creek Academy 575	31.00	15.00	1.00	3.00	2.00	4.00	5.00	1.00	2.00	2.00	2.00	4.00	3.00	2.00	0.00	
Rock Ridge Academy 580	45.00	14.00	3.00	3.00	2.00	4.00	2.00	3.00	5.00	6.00	4.00	5.00	3.00	3.00	2.00	
Arrowhead Academy 605	15.00	0.00	0.00	0.00	0.00	0.00	0.00	0.00	0.00	0.00	2.00	2.00	5.00	5.00	1.00	
Bethany Crisis Shelter 615	0.50	0.00	0.00	0.00	0.00	0.00	0.00	0.00	0.00	0.00	0.00	0.00	0.50	0.00	0.00	
Hospitals 630	29.00	4.00	0.00	0.00	0.00	3.00	0.00	1.00	3.00	5.00	5.00	5.00	4.00	2.00	1.00	
The Bridge 950	20.00	0.00	0.00	0.00	0.00	0.00	0.00	0.00	0.00	0.00	0.00	0.00	0.00	0.00	20.00	
Total:	8129.82	3028.00	610.67	602.00	597.00	608.00	617.00	604.00	619.00	619.00	631.48	653.29	685.36	650.43	632.59	

687 students - 43 Open Enrolled, 31 FT Residents, 613 PT Residents
average enrollment 0.25 or 2 classes

2025-2026 Month to Month Enrollment Changes by School

Month to Month	EOY	Total	Total	Total	Total	Total	Total	Total	Total	Total	Total	Current	MtoM	YTD	FROM	FROM	FROM
2025-2026	24-25	Sept	Oct	Nov	Dec	Jan	Feb	Mar	Apr	May	Jun	Month Dif	Net		Current Month-EOY	May '25	Current Month-Apr '25
Congdon Park 435	474.00	486.00	484.00	483.00	486.00	485.00	484.00	485.00	482.67	489.67	0.00	7.00		3.67	15.67	474.23	15.44
Homecroft 475	451.00	464.00	465.00	462.00	463.00	459.00	465.00	465.00	465.00	460.00	0.00	-5.00		-4.00	9.00	450.48	9.52
Lakewood 500	252.00	240.00	243.00	242.00	241.00	243.00	243.00	242.00	243.00	244.00	0.00	1.00		4.00	-8.00	254.01	-10.01
Lester Park 510	512.00	512.00	519.00	518.00	514.00	514.00	516.00	521.00	519.00	519.00	0.00	0.00		7.00	7.00	512.01	6.99
Lowell 520	306.00	304.00	303.00	305.00	305.00	307.00	312.00	312.00	313.00	313.00	0.00	0.00		9.00	7.00	309.03	3.97
Lowell Immersion 521	327.00	182.00	182.00	184.00	183.00	183.00	183.00	183.00	183.00	183.00	0.00	0.00		1.00	-144.00	328.00	-145.00
MacArthur 525	270.00	260.00	255.00	255.00	257.00	258.00	260.00	258.00	252.67	253.00	0.00	0.33		-7.00	-17.00	270.22	-17.22
Myers Wilkins 540	312.15	454.00	462.00	463.00	458.56	452.00	453.00	453.00	452.00	454.00	0.00	2.00		0.00	141.85	309.06	144.94
Piedmont 550	387.00	401.00	400.00	404.00	399.00	404.00	405.00	404.00	404.00	402.00	0.00	-2.00		1.00	15.00	386.00	16.00
Stowe 565	238.00	235.00	233.00	235.00	237.00	237.00	241.00	239.00	239.00	247.00	0.00	8.00	11.33	12.00	9.00	237.02	9.98
Lincoln Middle 225	667.87	719.86	698.86	701.86	703.86	700.86	687.86	689.86	684.86	680.86	0.00	-4.00		-39.00	12.99	670.89	9.97
Ordean East Middle 335	1073.61	1142.27	1130.27	1116.27	1119.27	1116.27	1121.27	1115.34	1114.34	1120.34	0.00	6.00	2.00	-21.93	46.73	1073.09	47.25
AE Online 650	166.24	49.67	112.16	133.16	142.22	134.27	179.71	182.16	179.17	173.93	0.00	-5.24		124.26	7.69	170.53	3.40
Denfeld 215	896.17	1040.60	1000.41	973.29	944.74	948.25	931.95	927.06	924.49	917.47	0.00	-7.02		-123.13	21.30	901.46	16.01
East 220	1382.11	1541.90	1460.81	1448.57	1432.62	1428.77	1390.90	1378.21	1377.22	1365.05	0.00	-12.17	-24.43	-176.85	-17.06	1386.68	-21.63
Merritt Creek Academy 81	84.33	80.00	83.00	82.00	85.86	82.00	85.00	83.00	83.00	89.00	0.00	6.00		9.00	4.67	84.00	5.00
ALC Seat Based 611	92.72	63.00	81.00	80.00	83.86	80.00	81.71	82.00	81.00	78.00	0.00	-3.00		15.00	-14.72	98.72	-20.72
Chester Creek Academy 575	31.00	28.00	30.00	31.00	29.00	29.00	30.00	31.00	33.00	31.00	0.00	-2.00		3.00	0.00	27.00	4.00
WHA RRA 580	46.00	38.00	43.00	43.00	44.00	41.00	44.00	43.00	44.00	45.00	0.00	1.00		7.00	-1.00	46.00	-1.00
Arrowhead Academy 605	22.33	8.00	24.00	18.00	23.00	15.00	16.00	16.00	15.00	15.00	0.00	0.00		7.00	-7.33	19.00	-4.00
Bethany Crisis Shelter 615	0.25	0.00	0.50	0.00	0.00	0.25	0.25	0.50	0.75	0.50	0.00	-0.25		0.50	0.25	0.00	0.50
Hospitals 630	23.00	2.00	20.00	16.00	19.86	16.00	22.00	21.00	25.00	29.00	0.00	4.00		27.00	6.00	22.00	7.00
The Bridge 950	16.00	23.58	24.58	23.58	24.58	24.58	25.00	24.00	23.00	20.00	0.00	-3.00	2.75	-3.58	4.00	17.00	3.00
Total:	8030.78	8274.88	8254.59	8217.73	8196.43	8158.25	8177.65	8155.13	8138.17	8129.82	0.00		-8.35	-136.71	99.04	8046.43	83.39
Change		244.10	-20.29	-36.86	-21.30	-38.18	19.40	-22.52	-16.96	-8.35	0.00						
Duluth Adult Education		367.00	525.00	612.00	689.00	726.00	775.00	876.00	966.00	1063.00		97.00					

2025-2026 Month to Month Enrollment Changes by Grade

Month to Month	Total	Total	Total	Total	Total	Total	Total	Total	Total	Total	Current	MtoM	YTD	Current
2025-2026	Sept	Oct	Nov	Dec	Jan	Feb	Mar	Apr	May	Jun	Month Dif	Net		Avg
EC	151.06	211.04	299.03	337.06	347.07	364.07	369.07	376.08	382.12	0.00	6.04		231.06	315.18
PK	21.94	19.96	81.94	80.94	79.93	79.93	79.93	76.91	75.90	0.00	-1.01	5.03	53.96	66.38
KA	132.00	144.25	147.00	150.00	152.00	155.00	154.00	153.67	157.67	0.00	4.00		25.67	149.51
KG	460.00	457.00	456.00	451.56	454.00	457.00	454.00	454.00	453.00	0.00	-1.00		-7.00	455.17
1	593.00	595.00	597.00	597.00	593.00	599.00	603.00	601.00	602.00	0.00	1.00		9.00	597.78
2	595.00	596.00	595.00	591.00	592.00	595.00	594.00	594.00	597.00	0.00	3.00		2.00	594.33
3	609.00	603.00	604.00	602.00	601.00	608.00	607.00	607.00	608.00	0.00	1.00		-1.00	605.44
4	614.00	623.00	618.00	618.00	614.00	617.00	616.00	612.67	617.00	0.00	4.33		3.00	616.63
5	600.00	604.00	607.00	604.00	603.00	604.00	607.00	603.00	604.00	0.00	1.00		4.00	604.00
6	631.00	623.00	616.00	621.00	616.00	615.00	614.00	616.00	619.00	0.00	3.00	16.33	-12.00	619.00
7	618.00	611.00	610.00	615.00	612.00	612.00	614.00	611.00	619.00	0.00	8.00		1.00	613.56
8	654.41	642.41	640.41	638.41	639.41	635.41	632.48	633.48	631.48	0.00	-2.00	6.00	-22.93	638.66
9	655.58	660.00	654.85	652.28	650.99	648.15	647.29	652.40	653.29	0.00	0.89		-2.29	652.76
10	701.00	708.56	706.00	699.99	700.81	706.10	700.21	697.07	685.36	0.00	-11.71		-15.64	700.57
11	684.72	685.09	672.28	667.78	658.85	658.28	662.43	656.43	650.43	0.00	-6.00		-34.29	666.25
12	727.17	702.28	694.19	688.41	671.19	667.71	649.72	646.45	632.59	0.00	-13.86	-30.68	-94.58	675.52
K 12 Total:	8274.88	8254.59	8217.73	8196.43	8158.25	8177.65	8155.13	8138.17	8129.82	0.00	-8.35	-8.35	-145.06	8189.18
Change		-20.29	-36.86	-21.30	-38.18	19.40	-22.52	-16.96	-8.35	0.00				

ISD 709 ACTIVE ENROLLMENT BY MONTH (K-12)

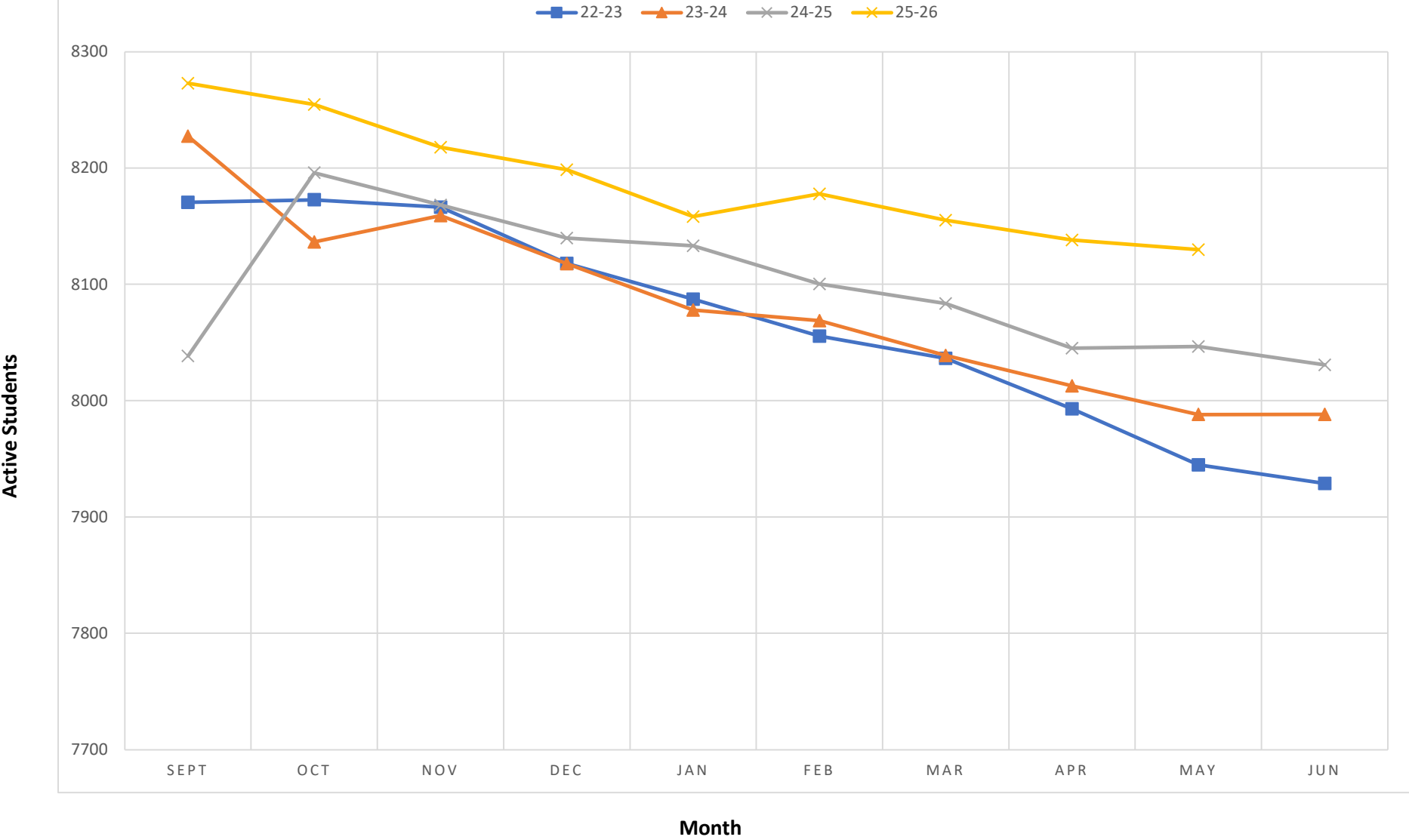

ISD 709 ACTIVE ENROLLMENT BY MONTH (K-12)

■ 22-23 ■ 23-24 ■ 24-25 ■ 25-26

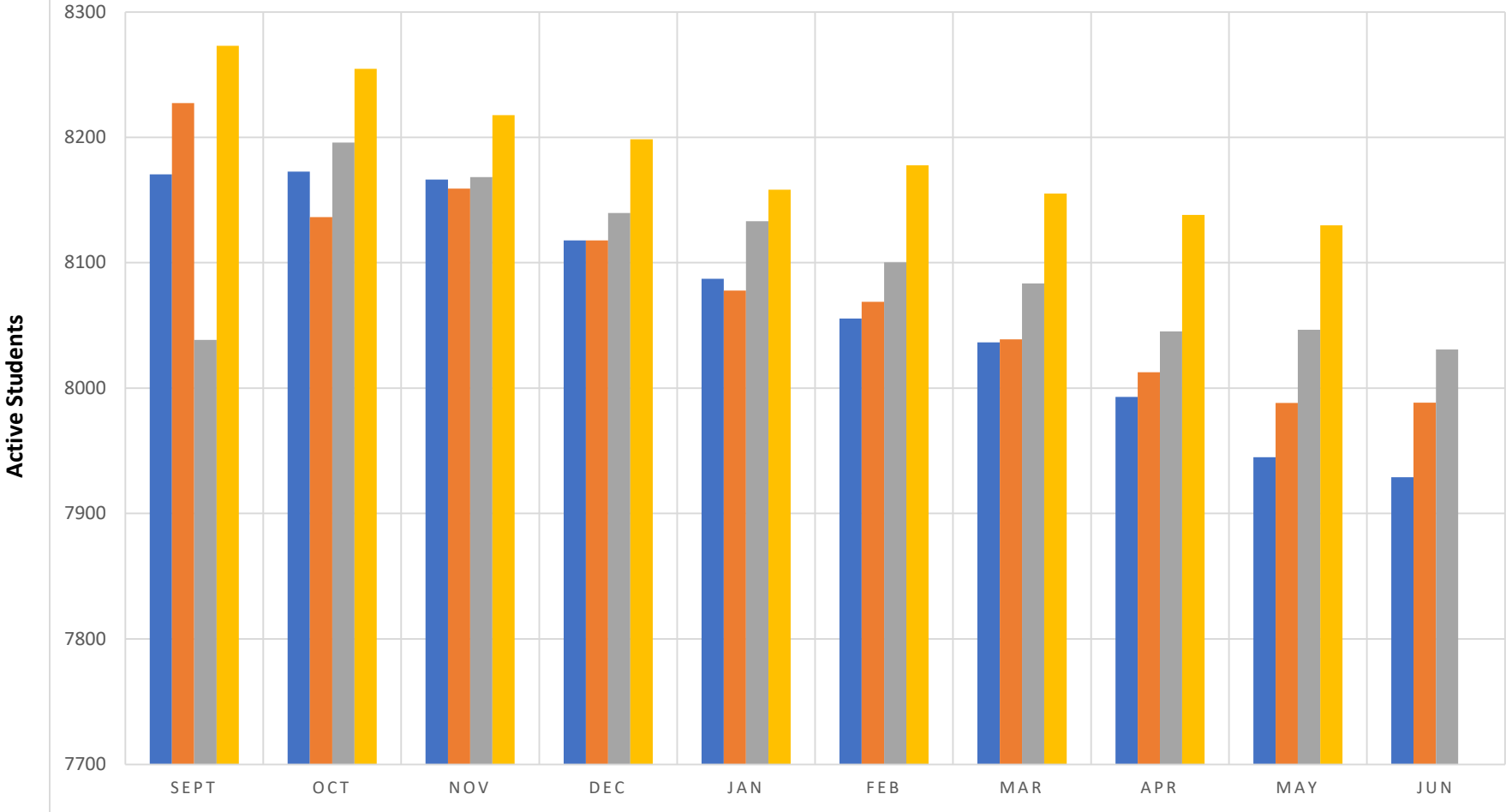

Month



Child Nutrition Report for May 2026 School Board Meeting Highlighting April 2026 Activities

Department:	Child Nutrition
HR Business Services Committee:	05.11.2026
Regular Board Meeting:	05.19.2026
Report Prepared By:	Sheila Oak

What We're Working On:

- Submitted the application for the Summer Meals program with the State of Minnesota. Sites were approved for:
Laura Macarthur, Denfeld, Lincoln Park, Myers, Lowell and Piedmont
We will also have community partnered sites with Boys and Girls clubs, AICHO, and a couple shelters.
More information about hours of operation, etc will be forthcoming.

Staffing Report:

- Assistant jobs open at:
Lincoln Park
East
Piedmont
Denfeld
Congdon
East
- Managers Jobs Open at:
Homecroft Elementary
Ordean Middle School
- Retirements:
Congratulations to Jodi Puff, Homecroft manager, who retired after spending 28 years in the Child Nutrition Program.
Congratulations to Debbie McKowski, Ordean East Manager, who will be retiring at the end of the school year. Debbie has spent 34 years with the Child Nutrition Program.

Facilities Report for May 2026 School Board Meeting Highlighting April 2026 Activities



Department: Facilities
HR|Business Services Committee: 05.11.2026
Regular Board Meeting: 05.19.2026
Report Prepared By: Bryan J. Brown

What We're Working On:

1. Efforts to staff our buildings are ongoing, with three positions recently filled following successful interviews.
2. Various summer training sessions are scheduled for Engineers, custodians, SSEI, and SSEII staff.
3. Recent project completions include floor finishing at the First Street Buildout building and lighting upgrades at Lowell Elementary and Lincoln Park Middle School.
4. Construction at First Street Buildout is progressing, supported by weekly onsite meetings.
5. Upcoming major maintenance includes a June start for the Stowe Elementary roofing project and ongoing planning for boiler upgrades at Lakewood Elementary.
6. Collaborative safety and utility initiatives are underway, including sprinkler system compliance upgrades with Summit Fire Protection and participation in the City of Duluth's Private Stormwater BMP Program to secure utility discounts.
7. Maintenance and inspections continue with Life Safety items at Myers-Wilkins, Stowe, Lowell, and Congdon Park; elevator maintenance at Laura MacArthur; and chiller debris encapsulation at Denfeld High School.
8. Proposals are being developed for the following initiatives:
 - a. Lincoln Park Middle School expansion joint repairs
 - b. Stowe Elementary playscape fence removal
 - c. Lester Park Elementary Forest creek cleanup
 - d. Rockridge Academy waterproofing
 - e. Congdon Park Elementary Pre-School fencing
 - f. District-wide pest treatment programming

Staffing Report:

- Vacant positions across several school buildings are currently posted and being actively recruited.

Safety Report for May 2026 School Board Meeting Highlighting April 2026 Activities



Department: Safety

HR|Business Services Committee: 05.11.2026

Regular Board Meeting: 05.19.2026

Report Prepared By: August Leopold

Health and Safety Topics:

- **Regulatory Requirements**

- Lead in Water testing has begun and is scheduled to be completed before the end of May
- AHERA asbestos three-year inspections have been completed
- Playground safety inspections have begun and will be completed before the end of May
- Annual operable wall basketball hoops inspections will be scheduled to be done by the end of June

- **Trainings and Planning**

- Lifeguard training has been completed
- Lock Out Tag Out (LOTO) standard operating procedure review has been completed
- Health, Safety, and Emergency Management breakout group presentation and Q&A was completed on the May 4th PD day
- Walkthroughs with Critical Response Group (CRG) have been scheduled for mid-May, CRG will be assisting in creating maps to be shared with first responders

- **Employee Injury Update for February**

- Our total case injury rate (TCIR) for March 2026 was 3.36, this is higher than last month. The increased TCIR for this month is likely due to the decrease in actual hours worked this month compared to last still with two recordable injuries. Our year to date TCIR is now 2.36. We had a total of 21 reports of injury with two of them being OSHA recordable. One recordable injury was from a student, the other from a fall on a school bus. Our highest category for reported injuries remains injured by student.

Incidents - Total Case Incident Rate



3.3572

April

Incidents - Employee Injuries by Cause of Injury (Primary)

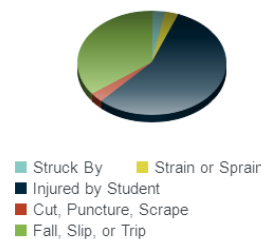

Year to Date

Technology Report for May 2026 School Board Meeting Highlighting April 2026 Activities



Department: Technology
HR|Business Services Committee: 05.11.2026
Regular Board Meeting: 05.19.2026
Report Prepared By: Greg Krueger

Manager's Minutes:

- Our department is reviewing a variety of proposed service and subscription renewals for the coming fiscal year. Several of our higher-cost services have rapidly escalated in cost. We're making changes to services in an effort to stay within our budget, working to right-size each contract and considering alternatives to existing services when practical. This year's review process should wrap up in June.
- Additional feedback on Artificial Intelligence implementation was sought from the District Advisory Committee and via a Thought Exchange survey sent to high school students. We're actively reviewing stakeholder feedback and discussing AI plans with district leadership.

What We're Working On:

- Our datacenter contract renewal has been finalized for the coming five years beginning this May. The contract reflects a reduction in occupied space, less electrical consumption allocation, and a lower overall cost in comparison to our present agreement.
- Technical preparations are underway for a change to our wide area network setup and addition of our First Street building to the district's network. These changes will be implemented by early July.
- Chromebooks have been ordered for next year's incoming class of students at Ordean and Lincoln Park middle schools.
- Additional interactive panels will be ordered to make use of the remainder of our department's budget this fiscal year.

Staffing Report:

- No staffing changes to report



Transportation Report for May 2026 School Board Meeting Highlighting April 2026 Activities

Department:	Transportation
HR Business Services Committee:	05.11.2026
Regular Board Meeting:	05.19.2026
Report Prepared By:	Jeremy Kasapidis

Manager's Minutes:

With the current school year concluding, we are turning our attention toward the summer and the 2026-2027 academic term. Our team is enthusiastic about several routing enhancements designed to provide more reliable and efficient service for our families next year. We also want to thank the staff members whose participation in our bi-weekly meetings remains essential to our ongoing service improvements.

What We're Working On:

- Refining and modifying current routes to facilitate a smoother transition into the 2026-2027 academic year
- Initiating early bus maintenance and mechanical reviews to ensure all vehicles meet DOT inspection standards

Upcoming Changes/Improvements to the Department:

- Working on transitioning over to Google forms for more of our driver reports

Staffing Report:

- We are currently holding at just enough drivers and helpers to keep routes running with minimal interruptions

RESOLUTION

Acceptance of Donations to Duluth Public Schools

WHEREAS, Minnesota Statute 465.03 requires a school district to accept donations by resolution expressed in the terms prescribed by the donor in full; and,

WHEREAS, acceptance of the donations in accordance with the donor's terms is in the best interest of the Duluth Public Schools:

NOW, THEREFORE, BE IT RESOLVED that the Duluth Public Schools does accept the below-described donations from said organizations in accordance with the terms set forth herein.

BE IT FURTHER RESOLVED that the Duluth Public Schools wishes to extend its grateful appreciation to these various individuals and organizations.

SCHOOL	DONOR	AMOUNT	RESTRICTION	COMMENTS
Denfeld	UMD Med School (SMED)	In-kind (Value \$3,500.00)	Tracey Holecek her Denfeld Nursing Assistant Class	(25) Blood Pressure Cuffs worth \$20 each = \$500 and (25) Stethoscopes worth \$120 each = \$3000
Denfeld	UMD Med School (SMED)	In Kind donations valued at \$565.00	Beth Rakowsky in the Denfeld Nursing Office	1 Blood Pressure Cuff worth \$20 and 1 Otoscope Set worth \$540 and 100 Otoscope Covers worth \$5.
Denfeld	Zachary Vavra	In-kind	Used for the Denfeld Automotive program	Donation of 1999 Ford Ranger. VIN: 1FTZR15V1XPB77486
Districtwide	Jennie Wabrowetz	In-kind - \$500 Dollar Value Clarinet	A donation for a band student in need - donated to the music curriculum specialist	
East	Michael Sharland	\$2,000.00	Donated to the Duluth East Band Program	
East	Nikolas Bayuk	\$200.00	For the Duluth East Band trip to New Orleans	
Lakewood	Anonymous	\$500.00	Lakewood Drama Club	
Lester Park	Lester Park Foundation	In-kind	New Laminator for the Office	New Laminator for the Office
Lester Park	Lester Park Foundation	In-kind	K-3rd Grades	Since we are no longer able to ask families for donations toward student Scholastic Magazines, the Foundation is covering the expense for next school year
Lester Park	Lester Park Foundation	In-kind	For Tanya Hallgren	To improve writing resources in Tanya Hallgren's 3rd grade classroom
Lincoln Park	Irving Community	\$500.00	For LPMS	To use in the school in the general activity fund

	Association Charitable Gambling Account			
Lincoln Park	Anonymous	In-kind	Give to families that are in need of these items	5 Sweaters/Sweatshirts, 6 Flannels, 3 shirts, 9 pairs women Pants
Lincoln Park	Anonymous	\$25.00	8th Grade Education Enrichment	BoostMySchool Donation
Lincoln Park	Jessica Lehet	\$100.00	\$50 for 8th Grade Education Enrichment; \$25 for One Book One Day; \$25 for Community School Pantry	BoostMySchool Donation
Lincoln Park	Nathan & Joanna Helder	\$100.00	\$50 for 6th Grade Enrichments; \$50 for 8th Grade Enrichments	
Lincoln Park	Bob Nygaard	In-kind	No restrictions	To give to the staff of LPMS as a thank you for working in the district
Lincoln Park	Kent & Barbara Nettnay	\$250.00	This donation is intended to purchase band instruments as deemed appropriate by the LPMS Band Director for use by LPMS students in honor of our grandson, Wilder T. Craft	
Myers-Wilkins	PHI Sigma Sigma Foundation	\$1,300.00	To provide lunch for teachers during teacher appreciation week	
Myers-Wilkins	PHI Sigma Sigma	\$4,500.00	For Field Day	
Myers-Wilkins	PHI Sigma Sigma	\$7,105.00	T-shirts for field day - for all students and staff	
Myers-Wilkins	North Shore Bank of Commerce	\$250.00	N/A	
Ordean-East	Ordean East PTA	\$1,500.00	To purchase correctly-sized boots for existing cross-country ski equipment.	PTA grant for teacher

Ordean-East	Ordean East PTA	\$200.00	To cover speaker fees to have Minnesota author William Durbin come in to speak to all 6th graders.	PTA grant for teacher Jody Goodreau
Ordean-East	Ordean East PTA	\$500.00	To help cover 6th grade field trip costs for students unable to pay the fee.	PTA grant for Stephanie Kiero
Ordean-East	Anonymous	\$2,500.00	Real Talk - Usage for Real Talk programming including but not limited to training/field trip/group events	Anonymous
Ordean-East	Benjamin A Gates	\$2,500.00	Real Talk	
Ordean East Middle School	Katie Benziger	\$50.00	One Book, One Day	
Ordean East Middle School	Julie Teichroew	\$150.00	One Book, One Day	
Ordean East Middle School	Hillary Olsen	\$25.00	One Book, One Day	
Ordean East Middle School	Jeanie Peterson	\$25.00	One Book, One Day	
Ordean East Middle School	Kathleen Bray	\$50.00	One Book, One Day	
Ordean East Middle School	Anonymous	\$100.00	One Book, One Day	
Ordean East Middle School	Milissa Brooks-Ojibway	\$10.00	One Book, One Day	
Ordean East Middle School	Kari Ramberg	\$25.00	One Book, One Day	
Ordean East Middle School	Nick Hickey	\$10.00	One Book, One Day	
Ordean East Middle School	Anonymous	\$25.00	One Book, One Day	
Ordean East Middle School	Renee Pedersen	\$5.00	One Book, One Day	
Ordean East Middle School	Shannon Hoffman	\$25.00	One Book, One Day	
Ordean East Middle School	Anonymous	\$50.00	One Book, One Day	
Ordean East Middle School	Keith Cich	\$25.00	One Book, One Day	

Ordean East Middle School	Anonymous	\$25.00	One Book, One Day	
Ordean East Middle School	Monica Ihrke	\$15.00	One Book, One Day	
Ordean East Middle School	Erin Otis	\$25.00	One Book, One Day	
Ordean East Middle School	Natalie Harkness	\$25.00	One Book, One Day	
Ordean East Middle School	Laura Laaksonen	\$50.00	One Book, One Day	
Ordean East Middle School	Anonymous	\$50.00	One Book, One Day	
Ordean East Middle School	Bethany Nelson	\$25.00	One Book, One Day	
Ordean East Middle School	Tiffany Pearson	\$25.00	One Book, One Day	
Ordean East Middle School	Anonymous	\$100.00	One Book, One Day	
Ordean East Middle School	Payroll Processing Plus	\$500.00	One Book, One Day	
Ordean East Middle School	Christine Miller	\$50.00	One Book, One Day	
Ordean East Middle School	Anonymous	\$100.00	One Book, One Day	
Ordean East Middle School	Andrea Knutson	\$50.00	One Book, One Day	
Ordean East Middle School	Sarah Hartley	\$25.00	One Book, One Day	
Ordean East Middle School	SYDNEY PALEN	\$25.00	One Book, One Day	
Ordean East Middle School	Michelle Foshay	\$25.00	One Book, One Day	
Ordean East Middle School	Amanda Sundin	\$25.00	One Book, One Day	
Ordean East Middle School	Janel Broman	\$25.00	One Book, One Day	
Ordean East Middle School	Anonymous	\$100.00	One Book, One Day	
Ordean East Middle School	Anonymous	\$25.00	One Book, One Day	
Ordean East Middle School	Maggie Wiederin	\$50.00	One Book, One Day	
Ordean East Middle School	Michell Hueffmeier	\$15.00	One Book, One Day	

Ordean East Middle School	Karen Rissling	\$25.00	One Book, One Day	
Ordean East Middle School	Jordan Brost	\$100.00	One Book, One Day	
Ordean East Middle School	Elizabeth Moncrief	\$25.00	One Book, One Day	
Ordean East Middle School	Joe and Miranda Moore	\$200.00	One Book, One Day	
Ordean East Middle School	JoHannah Orman	\$10.00	One Book, One Day	
Ordean East Middle School	Anonymous	\$50.00	One Book, One Day	
Ordean East Middle School	Lori Thompson	\$15.00	One Book, One Day	
Ordean East Middle School	Suzanne Vavrosky	\$25.00	One Book, One Day	
Ordean East Middle School	Lauren Giammar	\$50.00	One Book, One Day	
Ordean East Middle School	Tony Stensland	\$200.00	One Book, One Day	
Ordean East Middle School	SYDNEY PALEN	\$25.00	One Book, One Day	
Ordean East Middle School	Sarah Crowell	\$25.00	One Book, One Day	

RESOLUTION

Acceptance of Grant Awards to Duluth Public Schools

WHEREAS, Minnesota Statute 465.03 requires a school district to accept grants by resolution expressed in the terms prescribed by the donor in full; and,

WHEREAS, acceptance of the grant in accordance with the donor's terms is in the best interest of the Duluth Public Schools:

NOW, THEREFORE, BE IT RESOLVED that the Duluth Public Schools does accept the below-described grant from said organization in accordance with the terms set forth herein.

BE IT FURTHER RESOLVED that the Duluth Public Schools wishes to extend its grateful appreciation to this organization.

Organization	Authors or Contacts	School	Award Amount	Terms
Education Minnesota Foundation	Alyssa Rapp	Early Childhood	\$2,579.00	Attending the NHSA Parent Family Engagement conference

HUMAN RESOURCES ACTION ITEMS FOR: MAY 19, 2026

<u>CERTIFIED APPOINTMENT</u>	<u>POSITION</u>	<u>EFFECTIVE DATES</u>
ANDERSON, LUCAS K	LTS ELEMENTARY ART/CONGDON, (BA) III, 8, 0.8 CONGDON, 0.2 MERRITT CREEK ACADEMY GRANKE S.	04/23/2026
MITCHELL, NATHAN P	LTS VOCAL MUSIC TEACER/ORDEAN EAST, (MA) IV, 9, 0.4, STARR E.	04/13/2026
PRIESTLEY, TAYLOR S	LTS, ENGLISH TEACHER/EAST, (BA) III, 1, 1.0, ZOBEL J.	04/24/2026
REDIG, KAEDYN D	LTS SEB SPECIALIST/MYERS-WILKINS, (BA+45) III, 1, 1.0, SMITH M.	04/06/2026
<u>CERTIFIED RESIGNATION</u>	<u>POSITION</u>	<u>EFFECTIVE DATES</u>
BACHINSKI, SUSAN D	LTS PRE K - LAURA MACARTHUR ES	04/17/2026
GORDON, MADISON M	SPED SETTING III/IV - LINCOLN PARK MS	07/31/2026
KARG, GRETCHEN A	LITERACY LEAD TOSA - DW	06/05/2026
<u>NON-CERT APPOINTMENT</u>	<u>POSITION</u>	<u>EFFECTIVE DATES</u>
BAKER, AMANDA M	PRESCHOOL 2ND PARA/STOWE, 23/38WKS, \$20.80/HR, WITUCKI-VETSCH A.	04/13/2026
BROOKS, JASMINE M	HOULRY MONITOR/MYERS-WILKINS, UP TO 23HRS/38WKS, \$15.00/HR	04/13/2026
KOSKI, MATTHEW L	SPED BUILDING WIDE PARA/MYERS-WILKINS, 31.25/38WKS, \$20.80/HR, GOERDT J.	04/20/2026
LINDBERG, JENNIE L	HOURLY MONITOR/HOMECROFT, UP TO 23HRS/38WKS, \$15.00/HR	04/15/2026
MORBERG, HEATHER M	ASSISTANT MANAGER OF FACILITIES AND MAINTENANCE TRADES/DISTRICT WIDE, \$1,569/WKS, DEGRAEF J.	04/13/2026
MUNSON, LAURA A.M.	ATTENDANCE IMPROVMENT CLASSROOM TUTOR PARA/DENFELD, UP TO 20HRS/38WKS, \$19.23/HR	04/23/2026
PETERS, TODD A	HOURLY FOOD SERVICE/DISTRICT WIDE, UP TO 12HRS/38WKS, \$14.00/HR	04/14/2026
SHEVCHUK, ROBERT L, SR	FLOAT CUSTODIAN/DISTRICT WIDE, 40/25WKS, \$19.04/HR	05/04/2026
<u>NON-CERT RESIGNATION</u>	<u>POSITION</u>	<u>EFFECTIVE DATES</u>
GUERNSEY, LACECELIA L	CULTURAL IMMERSION PROG PARA - LOWELL ES	05/08/2026
PLZAK, BENJAMIN P	SPED BW PARA - EAST HS	06/05/2026
<u>NON-CERT RETIREMENT</u>	<u>POSITION</u>	<u>EFFECTIVE DATES</u>
FILLMORE, JOHN B	SPED BW PARA - EAST HS	06/05/2026
FRONDEN, KAREN A	ECFE PARA - LESTER PARK ES	06/04/2026
MCKOWSKI, DEBRA A	CAFETERIA MANAGER - ORDEAN-EAST MS	06/05/2026
PUFF, JODI M	CAFETERIA MANAGER - HOMECROFT ES	05/01/2026
<u>NON-CERT PRESUMED RESIGNED</u>	<u>POSITION</u>	<u>EFFECTIVE DATES</u>
CHRAPKOWSKI, SARAH E	SCHOOL CUSTODIAN 1 - ORDEAN-EAST MS	05/19/2026

Duluth Public Schools

REVISED BUDGET

HR/BS Services Committee Monthly Fund Balance Report May 11, 2026 Committee Meeting

BUDGET SUMMARY

05/08/26

Percent spent

REVENUES	25-26		25-26		25-26		25-26		
	CURRENT YEAR ADOPTED BUDGET		CURRENT YEAR REVISED BUDG		RECEIVED TO YEAR TO DATE		RECEIVED ENCUMBERED		
	FUND	Jul-25	JULY 25-26	July - June	July - June	July - June	BUDGET BALANCE		
General	1	\$ 134,020,612.52	\$ 137,502,407.11	\$ 87,665,778.92	\$ 17,575.41	\$ 49,819,052.78			64%
REVISED REVENUE - SPECIAL EDUCATION			\$ 5,256,647.00						
REVISED REVENUE - + 32 ADM adjustment			\$ 239,392.00	TOTAL REVISED REV = \$5,496,039.00					
Food Service	2	\$ 6,120,000.00	\$ 6,120,000.00	\$ 4,150,487.57	\$ -	\$ 1,969,512.43			68%
Transportation	3	\$ 3,866,200.00	\$ 3,866,200.00	\$ 3,421,241.65	\$ 82.88	\$ 444,875.47			88%
Community Ed	4	\$ 8,187,495.00	\$ 8,187,495.00	\$ 4,760,071.54	\$ -	\$ 3,427,423.46			58%
Operating Capital	5	\$ 4,680,435.48	\$ 1,974,644.89	\$ 1,130,087.02	\$ -	\$ 844,557.87			57%
Building Construction	6	\$ -	\$ -	\$ -	\$ -	\$ -			
Debt Service Fund	7	\$ 27,857,301.00	\$ 27,857,301.00	\$ 2,212,780.97	\$ -	\$ 25,644,520.03			8%
Trust Fund	8	\$ 320,000.00	\$ 320,000.00	\$ -	\$ -	\$ 320,000.00			0%
Dental Insurance Fund	20	\$ 959,836.00	\$ 959,836.00	\$ 994,059.63	\$ -	\$ (34,223.63)			104%
Student Acitivity	79	\$ 106,940.00	\$ 110,490.00	\$ 395,954.68	\$ -	\$ (285,464.68)			358%
REVENUE	TOTALS:	\$ 186,118,820.00	\$ 192,394,413.00	\$ 104,730,461.98	\$ 17,658.29	\$ -	\$ 82,150,253.73		54%

EXPENSES	25-26		25-26		25-26		25-26		
	CURRENT YEAR ADOPTED BUDGET		CURRENT YEAR REVISED BUDG		EXPENSES TO YEAR TO DATE		EXPENSES ENCUMBERED		
	FUND	Jul-25	JULY 25-26	July - June	July - June	July - June	BUDGET BALANCE		
General	1	\$ 128,563,977.06	\$ 141,996,095.72	\$ 109,635,129.36	\$ 2,438,118.14	\$ 29,922,848.22			79%
Food Service	2	\$ 6,095,464.00	\$ 6,095,464.00	\$ 4,529,171.47	\$ 1,136,491.61	\$ 429,800.92			93%
Transportation	3	\$ 7,864,200.00	\$ 7,864,200.00	\$ 8,487,285.49	\$ 294,117.01	\$ (917,202.50)			112%
Community Ed	4	\$ 7,725,252.00	\$ 7,725,194.86	\$ 6,158,288.20	\$ 36,240.97	\$ 1,530,665.69			80%
Operating Captial	5	\$ 5,648,724.89	\$ 5,648,724.89	\$ 6,353,094.96	\$ 1,763,653.39	\$ (2,468,023.46)			144%
Building Construction	6	\$ -	\$ -	\$ 11,465,226.72	\$ 16,995,519.09	\$ (28,460,745.81)			
Debt Service Fund	7	\$ 27,394,520.00	\$ 27,394,520.00	\$ 27,396,084.69	\$ -	\$ (1,564.69)			100%
Trust Fund	8	\$ 270,842.00	\$ 270,842.00	\$ -	\$ -	\$ 270,842.00			0%
Dental Insurance Fund	20	\$ 1,025,548.00	\$ 1,025,548.00	\$ 1,150,781.13	\$ -	\$ (125,233.13)			112%
Student Acitivity	79	\$ 86,750.00	\$ 753,465.85	\$ 279,013.61	\$ 64,993.44	\$ 409,458.80			46%
EXPENSE	TOTALS	\$ 184,675,277.95	\$ 198,774,055.32	\$ 175,454,075.63	\$ 22,729,133.65	\$ -	\$ 590,846.04		100%

** special ed orginial budget R & E	\$26,085,315.00
adjusted w/ cross subsidy R	\$31,341,962.00
adjusted w/cross subsidy E	\$36,480,478.00
adjusted budget per sped	\$38,642,836.68

Extra Curricular Fund 01 Prog 298
Revenue \$ 518,435.40
Expense \$ 639,194.37

**Fundraisers Reported
April 2026**

The following fundraisers were reported in the above timeframe and per Policy 511–Fundraising, require School Board approval:

School	Organization Fundraising	Estimated Profit	Description of Fundraiser
East HS	Schoolwide	\$1,000.00	Flowers for Graduates (Bouquets available for pick up at commencement)
East HS	History Day Showcase	\$400.00	History Day Showcase - GoFundMe



ICS
 1331 Tyler Street NE, Suite 101
 Minneapolis, Minnesota 55413
 Phone: (763) 354-2670
 Fax: (763) 780-2866

Project: S25052-LkwdESBoiler - Duluth Public Schools, ISD #709 -
 Lakewood Elementary Boiler Replacement
 5207 N. Tischer Road
 Duluth, Minnesota 55804

Contract Change Order #001: CCO #01 AG Obrien

CONTRACT COMPANY:	A.G. O'Brien Plumbing and Heating Co. 4907 Lightning Drive Duluth, Minnesota 55811	CONTRACT FOR:	SC-S25052-LkwdESBoiler-001:WS 01 - Mechanical
DATE CREATED:	5/08/2026	CREATED BY:	Mark Needham (ICS - Minneapolis, MN)
CONTRACT STATUS:	Pending - In Review	REVISION:	0
REQUEST RECEIVED FROM:		LOCATION	
DESIGNATED REVIEWER:		REVIEWED BY:	
DUE DATE:		REVIEW DATE:	
INVOICED DATE:		PAID DATE:	
REFERENCE:		CHANGE REASON:	Client Request
PAID IN FULL:	No	EXECUTED:	No
ACCOUNTING METHOD:	Amount Based	SCHEDULE IMPACT:	
FIELD CHANGE:	No	TOTAL AMOUNT:	\$234,309.90

DESCRIPTION:
 CE #001 - Include Propane Tank Procurement & Installation
 Furnish and install of the propane tank per Work Scope 04 and specification 23 13 00.

ATTACHMENTS:
[CE #001 - Include Propane Tank Procurement & Installation.pdf](#)

CHANGE ORDER LINE ITEMS:
CCO #001

#	Cost Code	Description	Type	Amount
1	05-5.01 - WS 01 - A.G. O'Brien	Include Propane Tank Procurement & Installation	Other	\$ 234,309.90
Subtotal:				\$234,309.90
Grand Total:				\$234,309.90

The original (Contract Sum)	\$ 494,390.00
Net change by previously authorized Change Orders	\$ 0.00
The contract sum prior to this Change Order was	\$ 494,390.00
The contract sum would be changed by this Change Order in the amount of	\$ 234,309.90
The new contract sum including this Change Order will be	\$ 728,699.90
The contract time will not be changed by this Change Order by	

A.G. O'Brien Plumbing and Heating Co.
 4907 Lightning Drive
 Duluth Minnesota 55811

ICS - Minneapolis, MN
 1331 Tyler Street N.E., Suite 101
 Minneapolis Minnesota 55413

Duluth Public Schools ISD #709
 709 Portia Johnson Drive
 Duluth Minnesota 55811

SIGNATURE _____ DATE _____ SIGNATURE _____ DATE _____ SIGNATURE _____ DATE _____



ICS
1331 Tyler Street NE, Suite 101
Minneapolis, Minnesota 55413
Phone: (763) 354-2670
Fax: (763) 780-2866

Project: S25052-LkwdESBoiler - Duluth Public Schools, ISD #709 -
Lakewood Elementary Boiler Replacement
5207 N. Tischer Road
Duluth, Minnesota 55804

CE #001 - Include Propane Tank Procurement & Installation

CREATED BY:	Mark Needham	CREATED DATE:	5/8/2026
STATUS:	Under Review	POTENTIAL CHANGE ORDER:	(None)
ASSIGNEE:	Paul Konkler (A.G. O'Brien Plumbing and Heating Co.)		

DISTRIBUTION:

SCOPE DESCRIPTION:

Include Propane Tank Procurement & Installation

REQUEST DETAILS:

CE #001 - Include Propane Tank Procurement & Installation

Furnish and install of the propane tank per Work Scope 04 and specification 23 13 00.

ATTACHMENTS:

RESPONSES

Date	Response By	Quote Amount	Schedule Impact	Comments	Attachments/Details
05/08/2026	Mark Needham	\$234,309.90	0 days	Includes OH&P for AG Obrien Management	

CHANGE ORDER COMPONENTS

CCO: (None)

NEGOTIATED AMOUNT:

Edwards Oil, Inc
 820 Hoover Road North
 Virginia, MN 55792
 Phone: 218-741-9634
 sskalko@eoctrimark.com

Date	Estimate #
5/8/2026	5446

Name / Address
AG O'Brien 4907 Lightning Drive Duluth, MN 55811

Terms
50% DOWN

THIS ESTIMATE IS NULL AND VOID AFTER 7 DAYS FROM DATE OF ESTIMATE. This estimate is for completing the job as described above. It is based on our evaluation and does not include material price increases or additional labor and material which may be required should unforeseen problems or adverse weather conditions arise after the work has started.

PROJECT
Lakewood - LP

Item	Description	Qty	Cost
	Used 18,000 gallon propane tank installed with the following		
	-Precast piers (Includes all dirtwork needed to complete)-		
	Class 1 Div 1 electric vaporizer		
	-Vapor bypass system		
	-Vapor distribution piping the tank/vaporizer to the school-		
	All valves and piping needed to fill the tank via transport		
	Vaporizer, Regulators, and Piping sized to deliver 4.5 million BTU		
PROPANE TANK 18,000	USED 18,000 GALLON PROPANE TANK ((1960's ERA))	1	
FREIGHT	Tank Freight	1	
PIERS#7	109" X 8" - 0" PRE-CAST PIER	2	
MISCELLANEOUS SUPPLIES	EXCAVATION AND DIRT WORK FOR PIERS	1	
MISCELLANEOUS SUPPLIES	ROCK FOR PIER BASE	1	
P-PADS-1	FELT - HIGH DENSITY FOAM PAD	2	
MISCELLANEOUS SUPPLIES	CRANE FEE	1	
MISCELLANEOUS SUPPLIES	4'X4' CONCRETE PAD FOR VAPORIZER	1	
H284-250	2' SEMI-INTERNAL PRESSURE RELIEF	2	
ME830	VALVE-LIQUID LEVEL VENT 34/" MPT X 1/4" FPT	1	
65529	1/4" x 2" XH Nipple	2	
0467129	1/4 FS THD 90 ELBOW	1	
ASG4004	4" NH3 0-400 PSI 4" Dial Bottom Stem	1	
C6342-11-108	MAGNETEL GAUGE FOR 108 ID TK EM HEMI HEAD 2	1	
LP-ME931	1/2" ADAPTER GAUGE MODEL B	1	
MEJ701	6" THERMOMETER 2" DIAL SS 1/2"	1	
C477-24-37	3" FISHER INTERNAL VALVE	1	
C477-16	2" FISHER INTERNAL VALVE	3	
4186535	3" X 2" SWAG NIPPLE XH	1	
4186513	2" X 1 1/4" SWAGE NIPPLE XH	1	
4186511	2" X 1" X-HEAVY SWAGE NIPPLE	2	
A7513AP	2" GLOBE VALVE FPT	1	
AL312P A7509BP	1-1/4 GLOBE VALVE	1	
A7507AP	1" GLOBE VALVE	1	
AL311P	1" ANGLE VALVE	1	

	Sales Tax (8.875%)	
	PLUS ANY APPLICABLE SALES TAX	Total
		341

Edwards Oil, Inc
 820 Hoover Road North
 Virginia, MN 55792
 Phone: 218-741-9634
 sskalko@eoctrimark.com

Date	Estimate #
5/8/2026	5446

Name / Address
AG O'Brien 4907 Lightning Drive Duluth, MN 55811

Terms
50% DOWN

THIS ESTIMATE IS NULL AND VOID AFTER 7 DAYS FROM DATE OF ESTIMATE. This estimate is for completing the job as described above. It is based on our evaluation and does not include material price increases or additional labor and material which may be required should unforeseen problems or adverse weather conditions arise after the work has started.

PROJECT
Lakewood - LP

Item	Description	Qty	Cost
AL313P	1-1/4" ANGLE VALVE	1	
A7514AP	2" ANGLE VALVE	1	
ME980C-6	3/4" FPT EMERGENCY SHUT OFF VALVE WITH CABLE	1	
4186479	LATCH 1 x 3/4 Swage Nipple	1	
ME880-6/28	VALVE-EX FLO 28 GPM BRASS MARSHALL EXCELSIOR	1	
TCHS2-200 8MMT-20	2" X 20" SS FLEX CONNECTOR	1	
0467398	2" FS UNION	1	
0467136	2" FS 90 DEGREE ELBOW	2	
0467199	2" FS 45 DEGREE ELBOW	1	
65614	2" X 6" XH NIPPLE	6	
2BSXHPE	2" X 21' SCH 80 BLACK PIPE (PER FOOT)	10	
0467396	1 1/4" FS UNION	1	
0467134	1 1/4" FS 90 DEGREE ELBOW	2	
0467146	1 1/4" FS 45 DEGREE ELBOW	1	
65592	1 1/4" X 6" XH NIPPLE	6	
114BSXHPE	1 1/4" X 21' SCH80 BLACK PIPE (PER FOOT)	10	
0467395	1" FS UNION	1	
65579	1" X 5" XH NIPPLE	2	
0467133	1" FS 90 DEGREE ELBOW	1	
0467132	3/4" FS 90 DEGREE ELBOW	3	
0467394	3/4" FS UNION	2	
65568	3/4" X 5" XH NIPPLE	6	
LP-B112600-3/4	STRAINER 3/4"	1	
MEH225	HYDROSTATIC BRASS 1/4" RELIEF VALVE MPT 440	6	
0490543 0484104	2-1/2" DIAL 0-300 PSI DRY GAUGE	2	
0407928	2-1/2" DIAL 0-30PSI PRESSURE GAUGE	2	
LP-217	Needle Valve 1/4" MALE X 1/4" Female	4	
LP-ME202SS	#54 GAUGE SNUBBER	2	
34BSXHPE	3/4" SCH 80 Pipe XH	30	
TX100	TOREXX 50 GPH ELECTRIC VAPORIZER	1	
114BSTC	1 1/4" X 21' SCH 40 BLACK PIPE (PER FOOT)	30	
0427018	1 1/4" RUB FP VALVE	4	
466206	1 1/4" 90 DEGREE ELBOW	8	
466316	1 1/4" TEE	4	
466265	1-1/4" x 1/2" Reducer Coupling	1	

Sales Tax (8.875%)
Total
352



PLUS ANY APPLICABLE
SALES TAX

Edwards Oil, Inc
 820 Hoover Road North
 Virginia, MN 55792
 Phone: 218-741-9634
 sskalko@eoctrimark.com

Date	Estimate #
5/8/2026	5446

Name / Address
AG Obrien 4907 Lightning Drive Duluth, MN 55811

Terms
50% DOWN

THIS ESTIMATE IS NULL AND VOID AFTER 7 DAYS FROM DATE OF ESTIMATE. This estimate is for completing the job as described above. It is based on our evaluation and does not include material price increases or additional labor and material which may be required should unforeseen problems or adverse weather conditions arise after the work has started.

PROJECT
Lakewood - LP

Item	Description	Qty	Cost
66430	1/2" X CL NIPPLE	1	
0467052	1/2" SQ. HEAD SOLID PLUG	1	
91085800	1/2" JOMAR BALL VALVE	1	
4186489	1-1/4" X 1" SWAGE NIPPLE	2	
627-7710	FISHER 1ST STAGE 5-20# PSIG	2	
289H-43	1" FNPT AI 10-20 PSI RELIEF REGULATOR	2	
466382	1 1/4" X 1 1/4" X 1" REDUCING TEE	2	
66346	1 1/4" UNION	6	
48831	TALL SINGLE COLUMN STRUT BASE	2	
48886	2" STRUT CLAMP	1	
48882	3/4" STRUT CLAMP	4	
48884	1-1/4" STRUT CLAMP	6	
11241065	White 1 5/8" Plastic End Cap	10	
48424	1 5/8" X 1-5/8" PRE-GALVANIZED 12GA STEEL HALF SLOT STRUT (PER FOOT)	80	
ME503A-16	3 1/4" M ACME X 2" MPT ADAPTER W/SCREEN	1	
MEP168	CABLE AND CRIMP FERRULE ACME CAPS KIT	2	
ME233	2-1/4" X 1-1/4" ACME ADAPTER	1	
ME431F	2-1/4" CAP	1	
ME441F	3-1/4" CAP	1	
1000990	20LB ABC CLASS FIRE EXTINGUISHER W/WALL HOOK	1	
CUSTOM EMERGENC...	12 X 18 CUSTOM EMERGENCY GAS SHUT OFF	1	
STORAGE-DECALS	STORAGE TANK DECAL SET	2	
45521	AIRCRAFT CABLE (PER FOOT)	75	
0529016	SINGLE SWIVEL EYE PULLEY	5	
RT 45	RT 45 TRENCHING PER FOOT	150	
MISCELLANEOUS SU...	MOB FEE	1	
LP-IPS125	1 1/4" IPS POLY TUBING (PER FOOT)	150	
WIR THHN 14 SOL YEL	TRACER WIRE	160	
FEI75901	1 1/4" IPS PERMASERT RISER W/ MECH. ENDS	3	
0467061	1 1/4" FS SQ. HEAD SOLID PLUG	1	
FEI50327010	1 1/4" IPS PERMA TEE	1	
MISCELLANEOUS SU...	MISCELLANEOUS SUPPLIES		
MISCELLANEOUS SU...	Travel Expense		
LABOR	LABOR		

Sales Tax (8.875%)
Total
263

PLUS ANY APPLICABLE
SALES TAX

Estimate

Edwards Oil, Inc
 820 Hoover Road North
 Virginia, MN 55792
 Phone: 218-741-9634
 sskalko@eoctrimark.com

Date	Estimate #
5/8/2026	5446

Name / Address
AG O'Brien 4907 Lightning Drive Duluth, MN 55811

Terms
50% DOWN

THIS ESTIMATE IS NULL AND VOID AFTER 7 DAYS FROM DATE OF ESTIMATE. This estimate is for completing the job as described above. It is based on our evaluation and does not include material price increases or additional labor and material which may be required should unforeseen problems or adverse weather conditions arise after the work has started.

PROJECT
Lakewood - LP

Item	Description	Qty	Cost
TANK PAINT	PAINTING OF TANK, WHITE, AT FINAL PLACEMENT Exclusions: Electrical By Others, Existing Driveway Work for Fuel Delivery. Project Change Orders from Customer or General Contractor	1	

Pre Tax Total: \$195,645.57
Sales Tax (8.875%) \$17,363.54
Total \$213,009.11



PLUS ANY APPLICABLE SALES TAX

274

AIA® Document G802® – 2017

Amendment to the Professional Services Agreement

PROJECT: *(name and address)*
Duluth Schools 2025 LTFM Phase 1
Projects

AGREEMENT INFORMATION:
Date:
July 25, 2025

AMENDMENT INFORMATION:
Amendment Number:
001
Date:
04-07-2026

OWNER: *(name and address)*
Duluth Public Schools, ISD #709
709 Portia Johnson Drive
Duluth, MN 55811

ARCHITECT: *(name and address)*
ICS Consulting, LLC
1331 Tyler Street N.E., Suite 101
Minneapolis, MN 55413

The Owner and Architect amend the Agreement as follows:
This Amendment supplements the B132-2019, Standard Form of Agreement Between Owner and Architect, Construction Manager as Adviser Edition, and the C132-2019, Standard Form of Agreement Between Owner and Construction Manager as Adviser, dated July 25, 2025, between Duluth Public Schools, ISD #709 and ICS for the project known as Duluth Schools 2025 LTFM Phase 1 Projects.

General Summary:
This Amendment reallocates the value associated with re-commissioning select HVAC Systems and Equipment from 'Section 5 - Construction Costs' to 'Section 3 - Fees/Services/Budgets' section of the overall project budget summary following MDE guidelines of 0.8% for required project commissioning.

The Architect's compensation and schedule shall be adjusted as follows:

Compensation Adjustment:
Resulting Section 3 - Fees/Services/Budgets adjustment: \$243,200.00
Resulting Section 5 - Construction Costs adjustment: (\$243,200.00)

Total Project Budget: \$38,660,200.00 (no change)

Schedule Adjustment:
N/A

ARCHITECT *(Signature)*

BY: Andy Faulkner, President
(Printed name, title, and license number if required)

Date

Signed by:

OWNER *(Signature)*

BY: John Magas, Superintendent
(Printed name and title)

5/8/2026

Date

OWNER *(Signature)*

BY: Kelly Durick Eder, School Board Chair

(Printed name and title)

Date

Minimize



Duluth Public Schools

2025 Referendum
ICS Project # TBD

Date Printed 4/13/2026

OVERALL PROJECT SUMMARY						
FUNDING:	ORIGINAL BUDGET	ADJUSTMENTS	REVISED BUDGET WITH ADJUSTMENTS	COST TO DATE	PENDING COSTS / ADJUSTMENTS	BUDGETED COST TO COMPLETE
1 FUNDING SOURCE(S)						
1.01 G.O. Bond Proceeds	\$ 38,660,200	\$ -	\$ 38,660,200	\$ -	\$ -	\$ 38,660,200
TOTAL REVENUE:	\$ 38,660,200	\$ -	\$ 38,660,200	\$ -	\$ -	\$ 38,660,200
COSTS:						
2 PERMITS / OWNER COSTS / OFF SITE COSTS						
2.03 Building Permit / Plan Review	\$ 200,000	\$ -	\$ 200,000	\$ 1,881	\$ -	\$ 198,119
SUBTOTAL:	\$ 200,000	\$ -	\$ 200,000	\$ 1,881	\$ -	\$ 198,119
3 FEES / SERVICES / BUDGETS						
3.01 Program Management Fees	\$ 4,271,200	\$ -	\$ 4,271,200	\$ 667,078	\$ 243,200	\$ 3,360,922
3.02 Program Management Reimbursable	\$ 250,000	\$ -	\$ 250,000	\$ -	\$ -	\$ 250,000
3.03 Construction Phase Site Services	\$ 980,000	\$ -	\$ 980,000	\$ -	\$ -	\$ 980,000
3.04 Site Surveys	\$ 40,000	\$ -	\$ 40,000	\$ -	\$ -	\$ 40,000
3.05 Soil Investigation	\$ 40,000	\$ -	\$ 40,000	\$ -	\$ -	\$ 40,000
3.06 Construction Testing	\$ 150,000	\$ -	\$ 150,000	\$ -	\$ -	\$ 150,000
3.07 Bond Finance/Issuance Costs	\$ 450,000	\$ -	\$ 450,000	\$ -	\$ -	\$ 450,000
3.08 Insurance - Builders Risk	\$ 65,000	\$ -	\$ 65,000	\$ -	\$ -	\$ 65,000
3.09 Legal, Etc.	\$ 50,000	\$ -	\$ 50,000	\$ -	\$ -	\$ 50,000
3.10 Moving / Relocation / Transportation Costs	\$ 150,000	\$ -	\$ 150,000	\$ -	\$ -	\$ 150,000
3.11 Other District Project Expenses	\$ 100,000	\$ -	\$ 100,000	\$ -	\$ -	\$ 100,000
SUBTOTAL:	\$ 6,546,200	\$ -	\$ 6,546,200	\$ 667,078	\$ 243,200	\$ 5,635,922
4 FURNITURE / EQUIPMENT / TECHNOLOGY						
SUBTOTAL:	\$ -	\$ -	\$ -	\$ -	\$ -	\$ -
5 CONSTRUCTION COSTS						
5.01 Re-Cx Solutions	\$ 1,350,000	\$ -	\$ 1,350,000	\$ -	\$ (243,200)	\$ 1,593,200
5.02 Lakewood Elementary Boiler Replacement	\$ 650,000	\$ 245,205	\$ 895,205	\$ -	\$ -	\$ 895,205
5.03 Stowe Elementary Roof Replacement	\$ 3,484,090	\$ -	\$ 3,484,090	\$ -	\$ -	\$ 3,484,090
5.04 Lincoln Park Lighting Updates	\$ 1,800,000	\$ (845,409)	\$ 954,591	\$ 591,537	\$ -	\$ 363,054
5.05 Lowell Elementary School Lighting Updates	\$ 600,000	\$ (55,545)	\$ 544,455	\$ 263,026	\$ -	\$ 281,429
5.06 Denfeld High School	\$ 7,150,000	\$ -	\$ 7,150,000	\$ -	\$ -	\$ 7,150,000
5.07 Lincoln Park Middle School	\$ 800,000	\$ -	\$ 800,000	\$ -	\$ -	\$ 800,000
5.08 East High School	\$ 5,000,000	\$ -	\$ 5,000,000	\$ -	\$ -	\$ 5,000,000
5.09 Ordean East Middle School	\$ 5,100,000	\$ -	\$ 5,100,000	\$ -	\$ -	\$ 5,100,000
5.10 Roofing & Misc. Repair	\$ 3,915,910	\$ 667,986	\$ 4,583,896	\$ -	\$ -	\$ 4,583,896
5.11 General Conditions Allowance	\$ 550,000	\$ -	\$ 550,000	\$ -	\$ -	\$ 550,000
SUBTOTAL:	\$ 30,400,000	\$ 12,236	\$ 30,412,236	\$ 854,563	\$ (243,200)	\$ 29,800,874
6 CONSTRUCTION CONTINGENCY						
6.01 Construction Contingency	\$ 1,500,000	\$ (12,236)	\$ 1,487,764	\$ -	\$ -	\$ 1,487,764
SUBTOTAL:	\$ 1,500,000	\$ (12,236)	\$ 1,487,764	\$ -	\$ -	\$ 1,487,764
TOTAL COSTS:	\$ 38,646,200	\$ (0)	\$ 38,646,200	\$ 1,523,521	\$ -	\$ 37,122,679
OVERALL PROJECT BALANCE:	\$ 14,000					

Teaching Learning and Equity Department/Program Board Summary Report

This report is designed for Department or Program Leaders to provide a concise, high-level overview of their area's status, activities, and future plans to the School Board.

Report Identification

Field	Information
Department/Program Name:	1 st Street Building (Duluth Education Center, DNT)
Report Title:	Construction Progress
Report Leader:	Bryan Brown
Date Submitted:	5-7-2026
Date of Board Meeting:	

Summary Report

I. Program Objectives & Goals (What are we trying to achieve?)

Construction Progress at the 1st Street Building (former DNT building located at 424 W 1st St, Duluth, MN). The building size is 72,000 sq ft, 51,000 sq ft of the building has been designed for program space; approximately 21,000 sq ft of space in the basement level is for future considerations.

Programs include:

- STEPS
- T-12/Bridge Special Education
- District-Wide Staff
- ECSE & Early Childhood
- District Testing/Screening
- Community Education
- ALC/AEO – Middle School & High School
- Adult Education

The goal is to complete construction in the summer of 2026.

II. Key Actions & Activities (What have we done recently?)

Construction continues to advance on schedule, with notable progress on both the 1st and 2nd floors. Roofing work has begun and will continue through the summer. Approximately 50 contractors are on-site daily.

Recent Construction Highlights

2nd Floor:

Major construction activities are nearing completion on the 2nd floor. Finishes—including doors, casework, carpet, and lockers—are largely installed. Remaining work includes central bathrooms and ceiling tile installation. A preliminary punch list for the 2nd floor is scheduled for May.

1st Floor:

Work is focused on ceiling, above-ceiling infrastructure, and painting. Interior finishes, and flooring to start in May.

III. Outcomes & Results (What was the impact?)

The project remains on schedule for completion in summer 2026.

IV. Next Steps & Future Focus (What is planned for the future?)

Construction Priorities

- Continue 1st-floor flooring installation through May and June.
- Tile installation on both the 1st and 2nd floors.
- Mechanical and electrical finish work on the 1st floor and basement.
- Mechanical infrastructure installation on the 3rd floor.
- Elevator installation.
- Roof installation.

Budget Updates

The construction budget is updated monthly with each pay application.

Current Summary:

- Total Budget: \$15,724,044
- Cost to Date: \$10,273,569
- Contingency Remaining: \$49,980
- FF&E Remaining: \$250,000

F. Current Project Photos



Tack Boards through the ramp



New Door Installation



Casework and Plumbing in the Science Room



Roof Installation



Locker Installation



Tile Installation

**Expenditure Contracts Signed
April 2026**

For your information, the Superintendent or the CFO, Executive Director of Business Services has signed the following expenditure contracts during the above timeframe.

*** Not to Exceed:** If asterisk is noted, then the contract has a guaranteed maximum price; District may not pay more than the dollar amount listed (this does not mean the vendor will invoice this amount and may invoice much less).

**** Contract is paid via monies from:**

DR = Department Restricted (LTFM, Indian Education Funds, Compensatory, Achievement Integration)

DU = Department Unrestricted (General Fund)

G = Grant (external grants from foundations such as Northland, Duluth Superior Area Community)

SAF = Student Activity Funds (monies raised by students, gate fees, etc.)

Name	Amount*	Contract Source**	Description
ICS	\$28,000.00*	Office of the Superintendent (DU)	District-Wide Comprehensive Capacity Study
Lake Superior College	\$160.00*	Office of the Superintendent (DU)	Usage of LSC Conference Room S207 for upcoming meeting – 6/15/26
Lake Superior College	\$160.00*	Office of the Superintendent (DU)	Usage of LSC Conference Room S207 for upcoming meeting – 7/29/26
Captivate Media + Consulting	\$3,000.00*	Communications Office (DU)	Special Education AnimatED video production
Susan Lehna	\$12,000.00*	TLE (DR)	Provide substitute principal services for ALC
Adela Alvarez	\$40/person based on attendance	TLE/Professional Development (DR)	Provide a CPR presentation during 5/4/26 PD Day
Thomlin/Lindsay Swan	\$150.00*	TLE/Professional Development (DR)	Show a documentary presentation and host a Q&A session during 5/4/26 PD Day
CFS Interiors & Flooring	\$43,415.00	Facilities (DR)	Remove and dispose of existing vinyl base, supply and install eco nights rubber sports tile over existing rubber flooring at EHS
Stretar Masonry & Concrete	\$65,200.00*	Facilities (DR)	District-Wide Annual Bricklayer Labor
Larson Elevator Company	\$41,900.00*	Facilities (DR)	District-Wide Annual Elevator Service

Hunt Electric	\$7,418.29*	Facilities (DR)	District-Wide Annual Service & Maintenance of Emergency Generators
Regional Contracting & Painting	\$44,622.00*	Facilities (DR)	District-Wide Annual Painting Labor
The Jamar Company	\$74,000.00*	Facilities (DR)	District-Wide Annual Plumbing Labor Services
A.W. Kuettel & Sons, Inc.	\$60,150.00*	Facilities (DR)	District-Wide Annual Roofing Labor
Per Mar Security Services	\$47,033.64*	Facilities (DR)	District-Wide Security System and Fire Detection Monitoring Services
Kelly Education	TBD	Human Resources (DR)	Amendment Two for annual substitute teaching services District-Wide
Ark Data Centers	\$2,552.58/month	Technology (DU)	Ark Datacenter month to month services – 60 months
Ark Data Centers	\$675.00/month	Technology (DU)	Ark Datacenter month to month services – 1 month – Specific to 1-pair fiber cross connect within the designated data center
Stone Ridge SDA Christian School	\$0.38/mile reimbursement	Transportation (DR)	Transportation reimbursement for parents who drive students from Stone Ridge SDA Christian School to ISD 709
Ricky White	\$6,000.00*	Am. Indian Edu. (DR)	Cultural services
Less Gibbons	\$1,000.00*	Am. Indian Edu. (DR)	Provide MC services for school Powwow, traditional knowledge and culturally specific services
Alex Kmett	\$1,000.00*	Am. Indian Edu. (DR)	Perform culturally specific services, activities and cultural knowledge as a Spiritual Advisor
Michael Kesner	\$1,000.00*	Am. Indian Edu. (DR)	Perform culturally specific services and activities, drumming and singing
Thomas Cain	\$1,000.00*	Am. Indian Edu. (DR)	Drumming, singing, dancing and traditional activities and cultural knowledge
Kasey Christjohn	\$1,000.00*	Am. Indian Edu. (DR)	Perform culturally specific services and activities, drumming and singing
Rizal Agaton Howes	\$1,000.00*	Am. Indian Edu. (DR)	Perform culturally specific services and activities, drumming and singing
Mark Steeno	\$1,000.00*	Am. Indian Edu. (DR)	Perform culturally specific services and activities, drumming and singing
Phyllis Pohl	\$5,000.00*	Am. Indian Edu. (DR)	Creation of traditional shawls to be used by Am. Indian students during the LPMS Powwow 5/9/26

Jakob Wilson	\$1,000.00*	Am. Indian Edu. (DR)	Provide culturally specific drumming and singing services
Dehwaywin Deleary	\$1,000.00*	Am. Indian Edu. (DR)	Provide culturally specific drumming and singing services
Bayada Home Health Care, Inc.	\$75.00/hour for RN or \$65.00/hour for LPN	Special Services (DR)	Health care services for student from 4/22/26 – 5/28/26
Jes Podpeskar	\$900.00*	Federal Programs (DR)	Create and run family bingo night around mental health for Piedmont ES
LeAnna Hudson	\$25,000.00*	Families in Transition/Early Childhood (DR)	FY27 support services for FIT/EC programming
Wolf Ridge Environmental Learning Center	\$26,125.00	Lester Park ES (DR)	5 th grade field trip for SY26-27
Tom Wegren	\$250.00*	Congdon Park ES (DU)	Spring concert rehearsal and performances
University of Wisconsin Superior	\$2,262.98*	Ordean-East MS (DU)	Rental of Thering Fieldhouse and Mortorelli Gymnasium – 5/1/26, 5/15/26, 5/29/26
University of Wisconsin Superior	\$409.87*	Ordean-East MS (DU)	Rental of full Thering Fieldhouse – 5/29/26



A LEONARDO Company

Duluth Public Schools - ISD#709

709 Portia Johnson Dr.

Duluth, MN 55811



Proposal for ISD#709 District-Wide Comprehensive Capacity Study

May 1, 2026

525 S. Lake Avenue Suite 222, Duluth, Minnesota 55802
Ph: (763) 354-2670 / Fax: (763) 780-2866 / ics-builds.com

District-Wide – Comprehensive Capacity Study

Duluth Public Schools

- | | |
|----------------------------|---|
| I. Scope Overview | <p>ICS Consulting, LLC ("ICS") is pleased to present this proposal to provide a comprehensive capacity study. The overall student capacity will be evaluated across the District's school facilities. This analysis will examine general education classroom capacity at the building and district-wide level, using a consistent methodology to determine the total number of students the facilities are capable of supporting.</p> <p>Deliverables will include a summary of building-level and district-wide capacity metrics, and identified areas of over- or under-utilization. Findings will be presented in a clear, data-supported format using tables, narratives, and graphics that are accessible to district leadership and stakeholders. The information will provide an objective foundation to support planning discussions, scenario development, and future facility and capital planning decisions.</p> |
| II. Schedule | <p>ICS will work with ISD#709 Schools staff to commence work upon acceptance of this proposal and will complete the work described in a timely fashion. ICS has the bandwidth to complete this work upon approval. Timing for completion of this work will rely on obtaining all necessary information and background information from the district and will rely on availability and access to administrative leadership at each building.</p> |
| III. Basis of Compensation | <p>Compensation for this service is a lump sum amount of \$28,800.</p> <p>Reimbursable expenses (i.e., mileage, per diem, reproduction, printing, postage, etc.) will be billed at the anticipated estimated cost of \$0 for this project.</p> |
| IV. Acceptance | <p>If this proposal is acceptable, please authorize us by signing a copy of this document and returning it to ICS. ICS will proceed with our scope of work upon receipt of your signed proposal.</p> |

Signature Page

Duluth Public Schools – Comprehensive Capacity Study

5/1/2026

Authorization to Proceed

We appreciate the opportunity to present this proposal for a Comprehensive Capacity Study. Please sign and return both copies of this document to our office. Upon receipt of both signed copies, a fully executed original copy will be forwarded back to you for your records. We will begin the project at the time of signature acceptance of this proposal.

ISD#709 Duluth Public Schools

5/4/26

Date

John Magas

Printed Name

John Magas

Authorized Signature

ICS

5/5/26

Date

ANDY FAULKNER

Printed Name

Andy Faulkner

Authorized Signature



FACILITIES USE AGREEMENT GENERAL PURPOSE ON-CAMPUS ONLY

THIS FACILITIES USE AGREEMENT is between the State of Minnesota, by and through the Board of Trustees of the Minnesota State Colleges and Universities on behalf of **Lake Superior College, 2101 Trinity Road, Duluth, MN 55811** ("Minnesota State") and **Duluth Public Schools, 709 Portia Johnson Dr, Duluth, Minnesota 55811** ("Licensee").

1. FACILITIES.

For purposes of this Agreement, "Facilities" shall mean:
Lake Superior College, 2101 Trinity Road, Duluth, MN 55811
Conference Room 5207
Airtame - screen sharing system

Parking will be available to Licensee at the following location: **Any unmarked parking space/row.**

2. GRANT OF LICENSE.

Minnesota State grants to Licensee a license to use the Facilities solely for the following purpose(s):
Cabinet Work Session

The estimated number of people expected to participate or attend is: **12.**

Licensee acknowledges and agrees that Minnesota State, its agents, employees, invitees, licensees and students may use any portion of the Facilities for any purpose whatsoever and at any time during the term of the Agreement, provided that such use shall not unreasonably disturb Licensee's use of the Facilities as provided in this Agreement. Licensee shall use the Facilities in accordance with the terms and conditions of this Agreement, all Minnesota State policies and procedures including all federal, State and local laws, ordinances, rules and regulations.

The parties agree that this agreement does not create a landlord-tenant relationship between them. Minnesota State is permitting Licensee to use the Facilities according to the terms of this Agreement. It is specifically understood that the permission to use the Facilities and the period of use are not exclusive to Licensee, and Minnesota State shall have the right to enter and use the

Facilities at all reasonable times for purposes of inspecting the same or for such other purposes as may be required by Minnesota State.

3. TERM AND TIME OF USE.

Licensee may use the Facilities during the following dates and times:

- **Monday, June 15, from 7:30AM – 4:30PM CST**

4. FEE.

For its use of the Facilities, Licensee agrees to pay to Minnesota State a fee of **One Hundred Sixty and 00/100 Dollars (\$160.00)**, which amount shall be payable in advance when Licensee signs this Agreement and delivers it to Minnesota State. Except as set forth in paragraph 17, if the Minnesota State cancels this Agreement prior to Licensee's use of the Facilities, Minnesota State will refund the fee to Licensee.

5. NOTICE AND CONTRACT ADMINISTRATION.

All notices, requests, and other communications between Licensee and Minnesota State that are required or that Licensee and Minnesota State elect to deliver shall be deemed sufficiently given or rendered if in writing and delivered to either party personally, by a recognized overnight courier service or by United States mail, first-class, certified or registered, postage prepaid, (return receipt required) and such notice shall also be sent as courtesy via email, and shall be sent to the respective addressee at the respective address and email address set forth below or to such other address or email address as the parties may specify in writing addressed as follows:

a. Minnesota State: **Lake Superior College**

Name: **Nickoel Anderson**, or their successor
Title: **Vice President of Finance and Administration**
Address: **2101 Trinity Road, Duluth, MN 55811**
Telephone: **218-733-7724**
E-Mail: nickoel.anderson@lsc.edu

b. Licensee: **Duluth Public Schools**

Name: **John Magas**, or their successor
Title: **Superintendent**
Address: **709 Portia Johnson Drive**
Telephone: **218-366-8752**
E-Mail: superintendent@isd709.org

Notices shall be deemed effective upon the earlier of receipt when delivered, or if mailed, upon return receipt. A courtesy notice sent via email shall be delivered to the designated email address of said addressee

6. MAINTENANCE OF FACILITIES.

Licensee agrees to maintain the Facilities in a clean and sanitary condition. After Licensee finishes using the Facilities, Minnesota State will inspect the Facilities and make any repairs or replace any missing or destroyed property, as it deems appropriate. Minnesota State will then submit an invoice to Licensee for the repairs or replacement of missing items, which Licensee agrees to pay within thirty (30) days. However, if the cost of repairs or replacement is estimated to exceed \$500,

Minnesota State shall be entitled to obtain payment of such amount from Licensee in advance. This provision will survive the termination of this Facilities Use Agreement.

7. RULES AND REGULATIONS.

Licensee agrees to honor and abide by all rules and regulations set forth by Minnesota State during its occupancy of the Facilities.

8. LICENSEE'S INSURANCE.

Licensee shall not occupy the Space under this Agreement until Licensee has obtained, at its sole expense, general liability and property damage insurance requirements as described below and naming **both Minnesota State Colleges and Universities and Lake Superior College, 2101 Trinity Road, Duluth, MN 55811** as additional insured and has provided a certificate of insurance to Minnesota State and said insurance has been approved by Minnesota State/State of Minnesota. All policies shall remain in force and effect throughout the term of this Agreement. If this Agreement is signed by Licensee less than thirty (30) days prior to the event, Licensee shall submit such evidence of insurance upon the signing of this Agreement. **No occupancy or use by Licensee may take place until satisfactory evidence of insurance coverage is provided to Minnesota State.**

a. GENERAL INSURANCE REQUIREMENTS

i. POLICY REQUIREMENTS

1. Workers' Compensation Insurance

- a. Statutory Compensation Coverage
- b. Coverage B – Employers Liability with limits of not less than:
 - \$100,000 Bodily Injury by Disease per Employee
 - \$500,000 Bodily Injury by Disease Aggregate
 - \$100,000 Bodily Injury by Accident

2. General Liability Insurance

- a. Minimum Limits of Liability:
 - \$2,000,000 – Per Occurrence
 - \$2,000,000 – Annual Aggregate
 - \$2,000,000 – Annual Aggregate applying to Products/Completed Operations
- b. Coverages:
 - Premises and Operations Bodily Injury and Property Damage
 - Personal & Advertising Injury
 - Blanket Contractual
 - Products and Completed Operations
 - Other; if applicable, please list _____
 - State of Minnesota or Minnesota State Colleges and Universities named as Additional Insured

3. Additional Insurance Conditions

- a. Licensee's policy(ies) shall be primary insurance to any other valid and collectible insurance available to the State of Minnesota with respect to any claim arising out of the Licensee's performance under this Agreement.
- b. Licensee agrees to notify the State of Minnesota within five (5) business days with a copy of the cancellation notice, unless Licensee's policy(ies) contain a provision that coverage afforded under the policy(ies) will not be cancelled without at least thirty (30) days advance written notice to the State of Minnesota.

- c. Licensee is responsible for payment of Agreement related insurance premiums and deductibles.
- d. If Licensee is self-insured, a Certification of Self-Insurance must be attached.
- e. Licensee's policy(ies) shall include legal defense fees in addition to the liability policy limits.
- f. Licensee shall obtain insurance policy(ies) from insurance company(ies) having an "AM Best" rating of A- (minus), Financial Size Category of VII or better, and authorized to do business in the State of Minnesota.
- g. An Umbrella or Excess Liability insurance policy may be used to supplement the Licensee's policy limits to satisfy the full policy limits required by the Agreement.

9. LIABILITY AND HOLD HARMLESS.

Licensee shall indemnify and hold Minnesota State harmless for any suits, actions or claims, whether formal or informal, direct or indirect, for injury, death, property damage or loss, including loss as a result of theft or misappropriation, made by or on behalf of any person or persons, firm or corporation arising out of or relating to the conduct, management or use of the Facilities by Licensee or arising out of any work or thing done in or about the Facilities or structures or equipment in the Facilities when such has been authorized by Licensee, except as such injury, death or property damage or loss is attributable solely to Minnesota State's negligence as determined by a court of law. This provision will survive the termination of this Agreement.

10. MINNESOTA DATA PRACTICES ACT.

Licensee agrees to comply with the terms of the Minnesota Data Practices Act, Minnesota Statutes, Chapter 13, in handling all data related to this Agreement.

11. AMERICANS WITH DISABILITIES ACT (ADA) COMPLIANCE.

Licensee agrees that in occupying the Facilities, it is responsible for complying with the Americans with Disabilities Act, 42 U. S. C. section 12101, et seq., and any regulations promulgated pursuant to the Act. Minnesota State IS NOT responsible for issues or challenges related to compliance with the ADA beyond its own routine use of facilities, services, or other areas covered by the ADA.

12. AUDIT.

The books, records, documents, and accounting practices and procedures of Licensee relevant to this agreement shall be subject to examination by Minnesota State, and either the Minnesota Legislative Auditor or Minnesota State Auditor for a period of six (6) years following the termination of this Agreement.

13. NO ASSIGNMENT; AMENDMENTS.

Licensee shall neither assign nor transfer any rights or obligations under this agreement without the prior written consent of Minnesota State. All amendments to this agreement shall be in writing and executed by a duly authorized representative of each party.

14. CANCELLATION.

This agreement may be canceled by either party at any time, for any reason, upon ten (10) days written notice to the other party.

15. NON-WAIVER.

No waiver by any party of a default or non-performance by the other party shall be deemed a waiver of any subsequent default or non-performance.

IN WITNESS WHEREOF, the parties have caused this contract to be duly executed intending to be bound thereby.

APPROVED:

1. LICENSEE: DULUTH PUBLIC SCHOOL

Licensee certifies that the appropriate person(s) have executed the Agreement on behalf of Licensee as required by applicable articles, bylaws, resolutions, or ordinances.

By (authorized signature and printed name) <i>John Magas</i> <small>John Magas (Apr 13, 2026 16:58:22 CDT)</small>	John Magas
Title	Superintendent
Date	04/13/2026

**2. MINNESOTA STATE COLLEGES AND UNIVERSITIES
LAKE SUPERIOR COLLEGE:**

By (authorized signature and printed name) <i>Nickoel Anderson</i> <small>Nickoel Anderson (Apr 13, 2026 16:30:59 CDT)</small>	Nickoel Anderson
Title	Vice President of Finance and Administration
Date	04/13/2026

3. AS TO FORM AND EXECUTION:

By (authorized signature and printed name) <i>Michelle Phernetton</i>	Michelle Phernetton
Title	Director of Business Services
Date	04/14/2026



FACILITIES USE AGREEMENT GENERAL PURPOSE ON-CAMPUS ONLY

THIS FACILITIES USE AGREEMENT is between the State of Minnesota, by and through the Board of Trustees of the Minnesota State Colleges and Universities on behalf of **Lake Superior College, 2101 Trinity Road, Duluth, MN 55811** ("Minnesota State") and **Duluth Public Schools, 709 Portia Johnson Dr, Duluth, Minnesota 55811** ("Licensee").

1. FACILITIES.

For purposes of this Agreement, "Facilities" shall mean:

Lake Superior College, 2101 Trinity Road, Duluth, MN 55811
Conference Room 5207
Airtame - screen sharing system

Parking will be available to Licensee at the following location: **Any unmarked parking space/row.**

2. GRANT OF LICENSE.

Minnesota State grants to Licensee a license to use the Facilities solely for the following purpose(s):

Cabinet Work Session

The estimated number of people expected to participate or attend is: **12.**

Licensee acknowledges and agrees that Minnesota State, its agents, employees, invitees, licensees and students may use any portion of the Facilities for any purpose whatsoever and at any time during the term of the Agreement, provided that such use shall not unreasonably disturb Licensee's use of the Facilities as provided in this Agreement. Licensee shall use the Facilities in accordance with the terms and conditions of this Agreement, all Minnesota State policies and procedures including all federal, State and local laws, ordinances, rules and regulations.

The parties agree that this agreement does not create a landlord-tenant relationship between them. Minnesota State is permitting Licensee to use the Facilities according to the terms of this Agreement. It is specifically understood that the permission to use the Facilities and the period of use are not exclusive to Licensee, and Minnesota State shall have the right to enter and use the

Facilities at all reasonable times for purposes of inspecting the same or for such other purposes as may be required by Minnesota State.

3. TERM AND TIME OF USE.

Licensee may use the Facilities during the following dates and times:

- **Wednesday, July 29, from 7:30AM – 4:30PM CST**

4. FEE.

For its use of the Facilities, Licensee agrees to pay to Minnesota State a fee of **One Hundred Sixty and 00/100 Dollars (\$160.00)**, which amount shall be payable in advance when Licensee signs this Agreement and delivers it to Minnesota State. Except as set forth in paragraph 17, if the Minnesota State cancels this Agreement prior to Licensee's use of the Facilities, Minnesota State will refund the fee to Licensee.

5. NOTICE AND CONTRACT ADMINISTRATION.

All notices, requests, and other communications between Licensee and Minnesota State that are required or that Licensee and Minnesota State elect to deliver shall be deemed sufficiently given or rendered if in writing and delivered to either party personally, by a recognized overnight courier service or by United States mail, first-class, certified or registered, postage prepaid, (return receipt required) and such notice shall also be sent as courtesy via email, and shall be sent to the respective addressee at the respective address and email address set forth below or to such other address or email address as the parties may specify in writing addressed as follows:

a. **Minnesota State: Lake Superior College**

Name: **Nickoel Anderson**, or their successor
Title: **Vice President of Finance and Administration**
Address: **2101 Trinity Road, Duluth, MN 55811**
Telephone: **218-733-7724**
E-Mail: nickoel.anderson@lsc.edu

b. **Licensee: Duluth Public Schools**

Name: **John Magas**, or their successor
Title: **Superintendent**
Address: **709 Portia Johnson Drive**
Telephone: **218-366-8752**
E-Mail: superintendent@isd709.org

Notices shall be deemed effective upon the earlier of receipt when delivered, or if mailed, upon return receipt. A courtesy notice sent via email shall be delivered to the designated email address of said addressee

6. MAINTENANCE OF FACILITIES.

Licensee agrees to maintain the Facilities in a clean and sanitary condition. After Licensee finishes using the Facilities, Minnesota State will inspect the Facilities and make any repairs or replace any missing or destroyed property, as it deems appropriate. Minnesota State will then submit an invoice to Licensee for the repairs or replacement of missing items, which Licensee agrees to pay within thirty (30) days. However, if the cost of repairs or replacement is estimated to exceed \$500,

Minnesota State shall be entitled to obtain payment of such amount from Licensee in advance. This provision will survive the termination of this Facilities Use Agreement.

7. RULES AND REGULATIONS.

Licensee agrees to honor and abide by all rules and regulations set forth by Minnesota State during its occupancy of the Facilities.

8. LICENSEE'S INSURANCE.

Licensee shall not occupy the Space under this Agreement until Licensee has obtained, at its sole expense, general liability and property damage insurance requirements as described below and naming **both Minnesota State Colleges and Universities and Lake Superior College, 2101 Trinity Road, Duluth, MN 55811** as additional insured and has provided a certificate of insurance to Minnesota State and said insurance has been approved by Minnesota State/State of Minnesota. All policies shall remain in force and effect throughout the term of this Agreement. If this Agreement is signed by Licensee less than thirty (30) days prior to the event, Licensee shall submit such evidence of insurance upon the signing of this Agreement. **No occupancy or use by Licensee may take place until satisfactory evidence of insurance coverage is provided to Minnesota State.**

a. GENERAL INSURANCE REQUIREMENTS

i. POLICY REQUIREMENTS

1. Workers' Compensation Insurance

- a. Statutory Compensation Coverage
- b. Coverage B – Employers Liability with limits of not less than:
 - \$100,000 Bodily Injury by Disease per Employee
 - \$500,000 Bodily Injury by Disease Aggregate
 - \$100,000 Bodily Injury by Accident

2. General Liability Insurance

- a. Minimum Limits of Liability:
 - \$2,000,000 – Per Occurrence
 - \$2,000,000 – Annual Aggregate
 - \$2,000,000 – Annual Aggregate applying to Products/Completed Operations
- b. Coverages:
 - Premises and Operations Bodily Injury and Property Damage
 - Personal & Advertising Injury
 - Blanket Contractual
 - Products and Completed Operations
 - Other; if applicable, please list _____
 - State of Minnesota or Minnesota State Colleges and Universities named as Additional Insured

3. Additional Insurance Conditions

- a. Licensee's policy(ies) shall be primary insurance to any other valid and collectible insurance available to the State of Minnesota with respect to any claim arising out of the Licensee's performance under this Agreement.
- b. Licensee agrees to notify the State of Minnesota within five (5) business days with a copy of the cancellation notice, unless Licensee's policy(ies) contain a provision that coverage afforded under the policy(ies) will not be cancelled without at least thirty (30) days advance written notice to the State of Minnesota.

- c. Licensee is responsible for payment of Agreement related insurance premiums and deductibles.
- d. If Licensee is self-insured, a Certification of Self-Insurance must be attached.
- e. Licensee's policy(ies) shall include legal defense fees in addition to the liability policy limits.
- f. Licensee shall obtain insurance policy(ies) from insurance company(ies) having an "AM Best" rating of A- (minus), Financial Size Category of VII or better, and authorized to do business in the State of Minnesota.
- g. An Umbrella or Excess Liability insurance policy may be used to supplement the Licensee's policy limits to satisfy the full policy limits required by the Agreement.

9. LIABILITY AND HOLD HARMLESS.

Licensee shall indemnify and hold Minnesota State harmless for any suits, actions or claims, whether formal or informal, direct or indirect, for injury, death, property damage or loss, including loss as a result of theft or misappropriation, made by or on behalf of any person or persons, firm or corporation arising out of or relating to the conduct, management or use of the Facilities by Licensee or arising out of any work or thing done in or about the Facilities or structures or equipment in the Facilities when such has been authorized by Licensee, except as such injury, death or property damage or loss is attributable solely to Minnesota State's negligence as determined by a court of law. This provision will survive the termination of this Agreement.

10. MINNESOTA DATA PRACTICES ACT.

Licensee agrees to comply with the terms of the Minnesota Data Practices Act, Minnesota Statutes, Chapter 13, in handling all data related to this Agreement.

11. AMERICANS WITH DISABILITIES ACT (ADA) COMPLIANCE.

Licensee agrees that in occupying the Facilities, it is responsible for complying with the Americans with Disabilities Act, 42 U. S. C. section 12101, et seq., and any regulations promulgated pursuant to the Act. Minnesota State IS NOT responsible for issues or challenges related to compliance with the ADA beyond its own routine use of facilities, services, or other areas covered by the ADA.

12. AUDIT.

The books, records, documents, and accounting practices and procedures of Licensee relevant to this agreement shall be subject to examination by Minnesota State, and either the Minnesota Legislative Auditor or Minnesota State Auditor for a period of six (6) years following the termination of this Agreement.

13. NO ASSIGNMENT; AMENDMENTS.

Licensee shall neither assign nor transfer any rights or obligations under this agreement without the prior written consent of Minnesota State. All amendments to this agreement shall be in writing and executed by a duly authorized representative of each party.

14. CANCELLATION.

This agreement may be canceled by either party at any time, for any reason, upon ten (10) days written notice to the other party.

15. NON-WAIVER.

No waiver by any party of a default or non-performance by the other party shall be deemed a waiver of any subsequent default or non-performance.

16. SECURITY.

Licensee hereby assumes all responsibility for security throughout its use of the Facilities.

17. DEFAULT.

In the event of any default by Licensee under the terms of this Agreement, Minnesota State may immediately terminate this Agreement and retain the license fee, in addition to any other remedies at law or in equity to which the Minnesota State may be entitled. The parties agree that the amount of damages in the event of a breach are uncertain, and the license fee is a reasonable estimate of such damages.

18. GOVERNING LAW and VENUE.

This Agreement, including all exhibits, amendments and supplements thereto, shall be governed by the laws of the State of Minnesota. Venue for all legal proceedings arising out of this contract, or breach thereof, shall be in the state or federal court with competent jurisdiction in Ramsey County, Minnesota.

19. ENTIRE AGREEMENT.

This Agreement represents the entire agreement between the parties and with regard to the stated subject matter and supersedes any previous discussions or agreements, either verbal or written that occurred between the parties with respect to this subject matter. This Agreement may not be amended except by written agreement signed by the parties hereto. In the event of any conflict or inconsistency between this Agreement and any riders, exhibits, addenda, or other document incorporated herein, this Agreement shall govern.

20. CLERICAL ERROR

Notwithstanding Clauses "Assignment, Amendments, and Entire Agreement" of this agreement, Minnesota State reserves the right to unilaterally fix clerical errors, defined as misspellings, minor grammatical or typographical mistakes or omissions, that do not have a substantive impact on the terms of this agreement without executing an amendment. Minnesota State must inform Licensee of clerical errors that have been fixed pursuant to this paragraph within a reasonable period of time.

21. OTHER PROVISIONS.

- Licensee agrees to abide by, and ensure all attendees abide by, LSC Policy 5.22 Acceptable Use of Computers and Information Technology Resources and the related Minnesota State Policies, and LSC Procedure 5.22.1 Acceptable Use of Computers and Information Technology Resources.
- Use of campus electronics and provided technology services is allowed only as instructed. Removing of cables or attempting to install personal devices on the system is prohibited without campus IT permission. To discuss your needs please contact IT at (218) 733-1016.
- Licensee has read and agrees to follow LSC Policy 6.7.1 – Procedure – Facilities Usage and Rental.
- Date(s) and/or time(s) of Agreement may be rescheduled upon mutual agreement between parties due to unforeseen circumstances.
- The Licensee shall not use Minnesota State's trademarks or photos of the campus to advertise the event, unless otherwise provided for in this Agreement. All posters, banners, marketing materials, advertisements, etc., containing LSC information will be subject to approval by the Director of Communications and Marketing and/or designee.

- This Agreement shall not be deemed to imply or represent that Minnesota State sponsors or supports any activities conducted by Licensee on the Facilities or elsewhere. All posters, banners, marketing materials, etc., will be subject to approval by the Director of Communications and Marketing and/or designee.
- Licensee agrees to abide by, and ensure all attendees abide by, LSC Policy 6.12 - Signage and Visual Communications and Policy 6.12.1 - Signage and Visual Communications for wayfinding and other temporary event signage on/around the campus.

The rest of this page intentionally left blank. Signature page to follow.

IN WITNESS WHEREOF, the parties have caused this contract to be duly executed intending to be bound thereby.

APPROVED:

1. LICENSEE: DULUTH PUBLIC SCHOOL

Licensee certifies that the appropriate person(s) have executed the Agreement on behalf of Licensee as required by applicable articles, bylaws, resolutions, or ordinances.

By (authorized signature and printed name)	<i>John Magas</i>	John Magas
Title	Superintendent of Schools	
Date	04/14/2026	

**2. MINNESOTA STATE COLLEGES AND UNIVERSITIES
LAKE SUPERIOR COLLEGE:**

By (authorized signature and printed name)	<i>Nickoel Anderson</i>	Nickoel Anderson
Title	Vice President of Finance and Administration	
Date	04/14/2026	

3. AS TO FORM AND EXECUTION:

By (authorized signature and printed name)	<i>Michelle Phernetton</i>	Michelle Phernetton
Title	Director of Business Services	
Date	04/15/2026	



VIDEO PRODUCTION | MOTION GRAPHICS | GRAPHIC DESIGN | CONSULTING

Special Education AnimatED

Motion Graphics

STATEMENT OF WORK

Prepared For:
Simone Zunich
Duluth Public Schools

Prepared By:
Jake Sturgis

04 / 12 / 2026

www.captivatemedias.us
612-314-3314

029

This Statement of Work (SOW) is between Duluth Public Schools and Capture Video LLC d/b/a Captivate Media + Consulting ("Captivate"), effective 04 / 12 / 2026 (the "Agreement"). This SOW is subject to the terms and conditions attached hereto. Any term not otherwise defined herein shall have the meaning specified in the Agreement. In the event of any conflict or inconsistency between the terms of this SOW and the terms of this Agreement, the terms of this SOW shall govern and prevail.

1. Client Information

Duluth Public Schools
c/o Simone Zunich
709 Portia Johnson Drive
Duluth, MN 55811

2. Project Overview

Captivate and Client agree to the below project summary, the project contract price, and the more detailed production outline.

PROJECT NAME	TYPE OF SERVICE	DURATION	FIRST DRAFT	FINAL DELIVERY
Special Education	Motion Graphics	approx. 3.5 minutes	April 20	April 24

Project Scope

PERIOD OF PERFORMANCE

The work will be performed between April 13, 2026 - April 24, 2026

SCOPE OF WORK

Captivate will customize the templated Special Education motion graphics video that is approximately 3.5 minutes in length and is based on a Captivate written script. Client will provide district logo and requested customizations for Captivate to update and customize the video. We will provide a closed caption file in English.

Up to one round of revisions is included for each video. If revisions extend beyond the original scope and script/outline of the videos, a change order will be created.

Project Timeline:

1. Contract is signed	Contract is signed authorizing Captivate to begin work	April 13
2. Logos and customizations	Client submits logo(s) and customizations to Captivate	by April 15
3. Production begins	Captivate will begin production of your animated video in English	by April 16
4. First draft of video	We will deliver the first draft of the Special Education video for you and your team to review	by April 20
5. Feedback Due	Client will send requested edits and feedback of the first version of the video by this date	by April 22
6. Final version of video	We will deliver the final version of Special Education video	by April 24

3. Project Costs and Payment

Client agrees that fees for the work performed as outlined in this SOW shall be paid as invoiced by Captivate.

Company will perform the Services set forth in Section 2 above in the amount of \$3,000, to be paid by Client as follows:

Name	Price
Amount due upon signing agreement	\$0.00
Amount due upon final completion of project, or the end of the project	\$3,000.00
Total	\$3,000.00

Revisions

The scope set forth in Section 2 above includes Company making one round of revisions to the video, provided the revisions are made within the scope of the approved video script. Client requested revisions beyond such scope will be invoiced at a rate of \$165 per hour.

4. Services Term

The term of this Schedule shall commence on the Schedule Effective Date and continue for a period of no more than 30 days.

CAPTIVATE MEDIA + CONSULTING

Terms and Conditions

This Master Services Agreement is effective on the date last written and is by and between Duluth Public Schools ("Client"), and Capture Video, LLC, a Minnesota limited liability company dba Captivate Media + Consulting ("Captivate").

1. DEFINITIONS

- 1.1. "Client Materials" means scripts, storyboards, product props, production notes, music, talent, creative guidance, releases, and recordings to be used in the Services and/or Deliverables.
- 1.2. "Confidential Information" means all nonpublic information disclosed by Client to Captivate, including without limitation, Captivate IP, products, services, tools, techniques, processes, strategic information, customer lists, supplier lists, documentation, data, designs, drawings, technical information, and client lists. Confidential information shall not include information which was previously lawfully known to Captivate, information which becomes publicly available other than by unauthorized disclosure, information developed by Captivate independent of Captivate's access to Confidential Information, or information received by Captivate from a third party.
- 1.3. "Deliverables" means any and all work product, video, reports, artwork, graphics, animations, materials and other deliverables created or developed by Captivate in the performance of the Services.
- 1.4. "Services" means the services described in the Project Summary.

2. SERVICES AND DELIVERABLES

- 2.1. Client hereby retains Captivate to provide the Services and provide the Deliverables set forth in the applicable Statement of Work.

3. FURNISHING OF MATERIALS, SERVICES, AND RELEASES

- 3.1. Client shall supply Captivate with all Client Materials as outlined in Section 3 above so Captivate has needed assets to create content for Client.
- 3.2. Client shall be solely responsible for obtaining all consents, releases, waivers and assurances (written and otherwise) from all participants provided by Client to Captivate for inclusion in any production pursuant to this Agreement, including without limitation from the parents or guardians of participants who are minors, as necessary for Client to comply with the terms of this Agreement. Client acknowledges and agrees that, as between Client and Captivate, any failure to obtain such consents, releases, liability waivers, or assurances shall be the sole responsibility and liability of Client. In addition, and without limiting the terms of the foregoing, Captivate shall have the right in its discretion to have each participant sign a written waiver and release directly between each participant and Captivate.

4. CHANGES IN SPECIFICATIONS

- 4.1. Captivate reserves the right to edit Deliverables at its discretion, provided that Client shall have the right to approve all final Deliverables. If at any time, Client desires to make any changes or variations to the Deliverables, or from any material or work in progress, and such changes result in additional cost to

Captivate, Captivate agrees to notify Client of the amount before any such additional costs are incurred and Captivate shall proceed only after receiving approval (written or oral) from Client. Reimbursement for such additional costs shall be payable in accordance with the terms of this Agreement for final payment.

5. OWNERSHIP

5.1. Captivate shall retain all ownership of Captivate's products, software, hardware, video, artwork, graphics, designs, intellectual property, ideas, designs, methodologies, and all patent, copyright, trademark and other intellectual property rights owned or developed prior to the execution of this Agreement or developed separately therefrom ("Pre Existing Captivate IP").

5.2. Subject at all times to Client's satisfaction of its payment obligations under this Agreement, any and all photographs, negatives, video footage, images, renderings and other related materials created or produced by Captivate in connection with the Deliverables shall be deemed a "work made for hire" under Title 17 of the United States Code, as amended. To the extent that any portion of the work is not a work made for hire, Captivate hereby grants an irrevocable, royalty-free, worldwide license in the Work. Client shall not reverse engineer, deconstruct, or make derivatives of Pre Existing Captivate IP.

5.3. Until notified in writing by Client, Captivate shall have a revocable license to use the Deliverable strictly for promotional purposes.

6. CONFIDENTIALITY

6.1. Captivate shall use the Confidential Information solely for the purposes of administering and otherwise implementing the terms of this Agreement and in the course of performing Captivate's obligations or the exercise of its rights. Captivate shall restrict disclosure of Confidential Information solely to those persons and entities with a need to know in the ordinary course of business.

7. INDEPENDENT CONTRACTOR

7.1. It is understood that Captivate is an independent contractor hereunder and Captivate agrees, warrants and represents that the Deliverables referred to in this Agreement shall be produced in compliance with all national, state and local laws. Nothing in this Agreement shall constitute an employment relationship between Captivate and Client.

8. PAYMENT

8.1. Client understands that the specified terms of payment under this Agreement are based upon timely cash payments within 30 days. If Client chooses to defer payment beyond the due date, Captivate may, at its sole discretion, charge Client as additional consideration an amount equal to the current prime rate +2% (as charged by Captivate's bank from time to time) on unpaid amounts until paid, compounded monthly. Ownership of all items created under this Agreement does not transfer from Captivate to Client until full payment is received.

9. INDEMNIFICATION

9.1. Captivate agrees to indemnify, defend, and hold harmless Client and its officers, employees, agents and licensees from and against any and all claims, actions, damages, liabilities and expenses arising out of

the breach of any obligations, warranty or representation of Captivate in this Agreement.

9.2. Client agrees to indemnify, defend, and hold harmless Captivate and its officers, employees, agents and licensees from and against any and all claims, actions, damages, liabilities and expenses, arising out of the breach of any obligation, warranty, or representation of Client in this Agreement.

10. LIMITATION OF LIABILITY AND DISCLAIMER

10.1. Disclaimer: EXCEPT AS EXPRESSLY SET FORTH IN THIS AGREEMENT, CAPTIVATE DOES NOT MAKE ANY EXPRESS OR IMPLIED WARRANTIES, REPRESENTATIONS, OR ENDORSEMENTS OF ANY KIND WHATSOEVER (INCLUDING, WITHOUT LIMITATION, WARRANTIES OF MERCHANTABILITY, FITNESS FOR A PARTICULAR PURPOSE, TITLE OR NON-INFRINGEMENT) WITH REGARD TO THE SERVICE OF DELIVERABLES.

10.2. Limitation of Liability: EXCEPT WITH RESPECT TO CAPTIVATE'S GROSS NEGLIGENCE OR WILLFUL MISCONDUCT, TO THE MAXIMUM EXTENT PERMITTED BY APPLICABLE LAW, IN NO EVENT SHALL CAPTIVATE OR ITS AFFILIATES, EMPLOYEES, MEMBERS, MANAGERS, GOVERNORS, AGENTS, CONTRACTORS, SUPPLIERS, REPRESENTATIVES, SUCCESSORS AND ASSIGNS BE LIABLE FOR ANY DAMAGES EXCEPT TO THE EXTENT OF ACTUAL, DIRECT DAMAGES BY CLIENT, NOT TO EXCEED FEES PAID BY CLIENT TO CAPTIVATE UNDER THE AFFECTED SCHEDULE.

10.3. CLIENT HEREBY ACKNOWLEDGES AND AGREES THAT THE DISCLAIMERS AND LIMITATIONS OF LIABILITY IN THIS SECTION ARE FUNDAMENTAL ELEMENTS OF THIS AGREEMENT AND THE SERVICES AND DELIVERABLES WOULD NOT BE PROVIDED TO CLIENT ABSENT SUCH DISCLAIMERS AND LIMITATIONS OF LIABILITY.

10.4. Any claims arising in connection of this Agreement must be brought within one (1) year of the date of the event giving rise to such action.

11. TERM AND TERMINATION

11.1. The term of this Agreement will commence upon signature of this Agreement and remain in effect until terminated in accordance with the terms of this Agreement.

11.2. Termination for Convenience: either party may terminate this Agreement for convenience and without cause at any time upon at least thirty (30) days prior written notice to the other party.

11.3. Termination for Cause: in the event that this Agreement is terminated for cause, it shall result in the immediate ceasing of all Services under the Project Description. In the event that either party makes an assignment of all or substantially all of its assets for the benefit of creditors, or becomes the subject of a voluntary or involuntary bankruptcy or the subject of any proceeding relating to insolvency, receivership, liquidation, or composition for the benefit of creditors and such actions are not dismissed within sixty (60) days of filing, the other party may immediately terminate the Agreement for cause.

11.4. Termination for Material Breach: either party may terminate this Agreement for cause if the other party breaches a material term or condition and fails to cure such breach within thirty (30) days of the date that written notice of the breach is provided to the breaching party.

11.5. Effect of Termination: Unless otherwise provided, Client shall promptly pay for all Services performed by Captivate under the applicable Statement of Work up to and including the effective date of termination. If Client has pre-paid Services on a fixed fee basis, Captivate shall refund any unearned fees as

of the effective date of termination. Notwithstanding the foregoing, any deposit paid by Client shall be nonrefundable.

12. CANCELLATION AND DELAYS

12.1. A cancellation or postponement is defined as a rescheduling of the production to a later specific date caused or directed by Client or a total cancellation of the project. If Captivate blocks out a specific period of time with the agreement that it represents a firm commitment from the Client, then Captivate makes no further efforts to sell the time.

12.2. Cancellation and Postponement: Motion Graphics

12.2.1. If notice of cancellation or postponement is given more than halfway through the production schedule of the job, Client shall be liable to Captivate for the full cost of the job as bid.

12.2.2. If notice of cancellation or postponement is given less than halfway through the production schedule of the job, Client shall be liable to Captivate for all out of pocket costs, plus 50% of the full production fee on the job as noted above.

12.3. Client Delays

12.3.1. The Parties acknowledge that delays due to unresponsiveness of the Client can cause significant monetary damage to Captivate. If Client is unresponsive with communications for more than 21 calendar days, the project will be placed on hold. Captivate will make at least three attempts to contact the client via email and/or phone and the 21 calendar days will begin on the day of the first email or attempted phone contact being attempted. In addition to the costs outlined in Section 3 of the agreement, Client will be charged \$500 for costs related to additional time and meetings needed to restart the project in addition to the fees contemplated hereunder this agreement. If the Client does not want to restart the project, the Cancellation process outlined in section 12 of this agreement will be followed and the additional \$500 will not be charged. In the event of a delay due to client unresponsiveness of more than 21 calendar days, the invoicing schedule contemplated hereunder this agreement may be delayed by no more than 30 calendar days. Captivate is not obligated to meet agreed upon project deadlines if Client is unresponsive.

13. INTENTIONALLY DELETED

14. TAXES

14.1. Any sales tax, use tax, or other tax payable on the production and delivery of the items created under this Agreement shall be the responsibility of Client who shall pay, defend and hold harmless Captivate from payment of any such taxes.

15. ASSIGNMENT

15.1. This Agreement may not be assigned by either party without the written consent of the other.

16. DISPUTE RESOLUTION

16.1. Any controversy or claim arising out of or related to this Agreement shall be settled by arbitration administered by the American Arbitration Association in accordance with its Commercial Arbitration Rules conducted in Hennepin County, Minnesota by an arbitrator selected under the Commercial Arbitration Rules,

and judgment on the award rendered by the arbitrator may be entered in any court having jurisdiction thereof. This Section shall not apply to any cause of action for which a party may be entitled to injunctive relief. The prevailing party in any legal action shall be entitled to reasonable attorney's fees and costs in connection with the legal proceedings.

17. MODIFICATION

17.1. This Agreement and any Addends attached hereto shall constitute the entire agreement between Captivate and Client. Any amendments hereto must be in writing and signed by each party.

18. CAPTIONS

18.1. The captions are inserted only as a matter of convenience and for reference and in no way define, limit or describe the scope or intent of this Agreement or of any provision hereof.

19. NO WAIVER

19.1. Failure of any party to this Agreement to exercise any rights shall not constitute a waiver of those rights.

20. ENFORCEABILITY

20.1. If one or more of the provisions of this Agreement shall be held unenforceable, it shall not affect the enforceability of the other provisions.

21. APPLICABLE LAW

21.1. This Agreement shall be governed by, construed and enforce according to the laws of the state of Minnesota, without regard to its conflict or choice of law principles. Any action arising out of or relating to this Agreement shall be brought only in the state and federal courts of Hennepin County, Minnesota, and all parties expressly consent to such court's jurisdiction and irrevocably waive any objection with respect to the same.

AGREED AND SIGNED:

Client:

Capture Video LLC dba Captivate Media + Consulting

Simone Zurich

Jacob Sturgis

By: Simone Zurich

By: Jacob Sturgis

Its: Exec. Dir. of Finance & Business Services

Its: Founder & CEO

Date: 04 / 13 / 2026

Date: 04 / 12 / 2026



CERTIFICATE *of* SIGNATURE

REF. NUMBER
KEFJM-R99UV-KAUCQ-C2E9R

DOCUMENT COMPLETED BY ALL PARTIES ON
13 APR 2026 13:49:18
UTC

SIGNER

TIMESTAMP

SIGNATURE

JAKE STURGIS

EMAIL
SALES@CAPTIVATEMEDIA.US

SENT
12 APR 2026 23:44:22
SIGNED
12 APR 2026 23:44:22

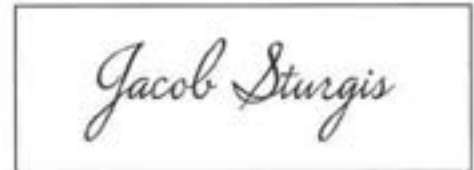

IP ADDRESS
69.180.171.244

LOCATION
PLYMOUTH, UNITED STATES

SIMONE ZUNICH

EMAIL
SIMONE.ZUNICH@ISD709.ORG

SHARED VIA
LINK

SENT
12 APR 2026 23:44:22
VIEWED
13 APR 2026 13:47:48
SIGNED
13 APR 2026 13:49:18



IP ADDRESS
24.158.25.245

LOCATION
DULUTH, UNITED STATES



AGREEMENT

THIS AGREEMENT, made and entered into this 27 day of April 2026 , by and between Independent School District #709, a public corporation, hereinafter called District, and Susan Lehna, an independent contractor, hereinafter called Contractor.

THE PURPOSE OF THE AGREEMENT is to set out the terms and conditions whereby Contractor will provide programs or services for the District at the times and locations set forth in this Agreement.

The terms and conditions of this Agreement are as follows: *(insert here or attach as appropriate)*

1. Dates of Service. This Agreement shall be deemed to be effective as of Tuesday, April 28, 2026 and shall remain in effect until June 30, 2026 , unless terminated earlier as provided for herein, or unless and until all obligations set forth in this Agreement have been satisfactorily fulfilled, whichever occurs first.

2. Performance. Provide substitute principal services for the Alternative Learning Center, including supervision of the seat-based program from 8:00 AM to 1:00 PM (or extended hours as needed) daily on Monday - Thursday, excluding the dates of May 10-19. The term for seat-based services will conclude on June 5, 2026. The contractor is available to extend services through June 30, 2026 depending on the programming required for summer session.

Substitute principal services include dealing with general school operations, general problem-solving and addressing student behaviors.

The work of the substitute principal will be overseen by the Director of Secondary Education. Time will be recorded and submitted for approval at the rate of \$80/hour not to exceed \$12,000 per contract on an Invoice/ Reimbursement form.

3. Background Check. *(applies to contractors working independent with students)*

Contractor must provide an executed criminal history consent form and a money order or check payable to the District in an amount equal to the actual cost of conducting a criminal history background check on all of its employees assigned to the program. Contractor is precluded from performance of contract until the results of the criminal background check(s) are on file.

If Contractor has already completed background checks for their business needs, Contractor stipulates that the background checks are completed, on file, and will be made available for review if the District should request.

Contractor will notify the District of any individual working in our schools with convictions of a gross misdemeanor or felony.

4. **Reimbursement.** In consideration of the performance of Contractor of its obligations pursuant to this Agreement, District hereby agrees to reimburse Contractor for its services and expenses in performing said obligations up to a sum not to exceed \$12,000 in total.

Contractor is required by Minnesota Statutes, Section 270.66, subd. 3, to provide their Taxpayer Identification Number (TIN) used in the enforcement of Federal and State tax laws. The TIN will be available to Federal and State tax authorities and State personnel involved in the payment of State obligations. This Agreement will not be approved unless TIN is provided.

5. **Requests for Reimbursement.** The terms of payment under this Agreement are as follows:

- a. Payment shall be made by the District within 30 days of submission of a proper invoice by the Contractor;
- b. Any other terms of payment in the performance of services are incorporated by reference in this Agreement.

6. **Propriety of Expenses.** The fact that the District has reimbursed Contractor for any expense claimed by Contractor shall not preclude District from questioning the propriety of any such item. District reserves the right to offset any overpayment or disallowance of any item or items at any time under this Agreement by reducing future payments to Contractor. This clause shall not be construed to bar any other legal remedies District may have to recover funds expended by Contractor for disallowed costs.

7. **Ownership of Materials.** The District reserves the rights to reproduce the programming in any fashion, or appropriate the contents of the programming, or any portion thereof, to its own use for any and all programs, forms and other materials that Contractor has provided, prepared, or utilized in performance of the terms of this Agreement.

8. **Independent Contractor.** Both the District and Contractor agree that they will act as an independent contractor in the performance of its duties under this Agreement. Nothing contained in this Agreement shall be construed as in any manner creating a relationship of joint venture between the parties, which shall remain independent contractors with respect to all actions performed pursuant to this Agreement.

Accordingly, Contractor shall be responsible for payment of all taxes, including Federal, State, and local taxes, arising out of Contractor's activities in accordance with this Agreement, including by way of illustration, but not limited to, Federal and State income tax, Social Security tax, Unemployment Insurance taxes, workers compensations, and any other taxes or business license fees as required.

9. **Indemnity and defense of the District.** Contractor hereby agrees to defend, indemnify and hold the District harmless from all claims relating to its work pursuant to this Agreement.

In the event that Contractor breaches its obligation to defend, indemnify and hold the District harmless, then in addition to its other damages the District shall be entitled to recover its attorney's fees and costs and disbursements incurred in enforcing this Agreement.

10. **Notices.** All notices to be given by Contractor to District shall be deemed to have been given by depositing the same in writing in the United States Mail: ISD 709, Duluth Public Schools, Attn: Jen Larva, Director of Secondary Education, 709 Portia Johnson Drive, Duluth, MN 55811.

All notices to be given by District to Contractor shall be deemed to have been given by depositing the same in writing in the United States Mail to 2935 Lady Nicole Lane, Duluth MN 55803.

11. **Assignment.** Contractor shall not in any way assign or transfer any of its rights, interests or obligations under this Agreement in any way whatsoever without the prior written approval of the District.

12. **Modification or Amendment.** No amendment, change or modification of this Agreement shall be valid unless in writing signed by the parties' hereto.

13. **Governing Laws.** This Agreement, together with all its paragraphs, terms and provisions is made in the State of Minnesota and shall be construed and interpreted in accordance with the laws of the State of Minnesota.

14. **Entire Agreement.** This Agreement contains the entire understanding of the parties hereto with respect to the subject matter hereof and shall not be changed or otherwise altered except by written agreement of the parties.

15. **Cancellation.** Either party shall have the right to terminate this Agreement, without cause, upon (30) days written notice to the other party as provided for in this Agreement.

16. **Data Practices.** Contractor further understands and agrees that it shall be bound by the Minnesota Government Data Practices Act (Minnesota Statutes 13.03-13.04) with respect to "data on individuals"; as defined in 13.02, subd. 5 of that Statute) which it collects, receives, stores, uses, creates or disseminates pursuant to this Agreement.

17. **Insurance.** (If applicable) Contractor shall not commence work under the contract until they have obtained all the insurance described below and Duluth Public Schools has approved such insurance. Contractor shall maintain such insurance in force and effect throughout the term of the contract.

Contractor is required to maintain and furnish satisfactory evidence of the following insurance policies:

Workers' Compensation Insurance: Contractor must provide Workers' Compensation insurance for all its employees and, in case any work is subcontracted, Contractor will require



the subcontractor to provide Workers' Compensation insurance in accordance with the statutory requirements of the State of Minnesota including Coverage B, Employer's Liability.

Commercial General Liability: Contractor is required to maintain insurance protecting it from claims for damages for bodily injury, including sickness or disease, death, and for care and loss of services as well as claims for property damage, including loss of use which may arise from operations under the Contract whether the operations are by the contractor or subcontractor or by anyone directly or indirectly employed under the contract.

18. **Conflict of Interest and Fiduciary Duty:** All contractors doing business with the District agree to follow Policy 307 - Conflicts of Interest and Fiduciary Duty. This policy is located on the District's website.

THE REMAINDER OF THIS PAGE IS LEFT INTENTIONALLY BLANK

AS EVIDENCE OF THEIR ASSENT TO THE TERMS AND CONDITIONS OF THIS AGREEMENT, set forth above, the parties hereto have caused this Agreement to be executed by their duly authorized officers as of the day and year first above written.

  4-28-26

Contractor Signature _____ SSN/Tax ID Number _____ Date 4-28-26



Program Director _____ Date _____

Please note: All signatures *must* be obtained AND the following *must* be completed by the Program Director before submission to the CFO for review and approval.

This contract is funded by either:

1. The following budget (include full 18 digit code); or
2. will be paid using Student Activity Funds; or
3. is no cost contract (e.g. Memorandum of Understanding).

Please check the appropriate line below:

X Check if the contract will be paid using District funds and enter the budget code in the top line below (enter in blank spots following the example).

Check if the contract will be paid using Student Activity Funds

Check if the contract is a no-cost contract such as a Memorandum of Understanding

01	E	611	211	303	305	000



James Quinn

4/29/26

Exec. Dir Finance & Business Services / Superintendent of Schools / Board Chair

Date

AGREEMENT

THIS AGREEMENT, made and entered into this 04/28/2026 by and between Independent School District #709, a public corporation, hereinafter called District, and Adela Alvarez, an independent contractor, hereinafter called Contractor.

THE PURPOSE OF THE AGREEMENT is to set out the terms and conditions whereby Contractor will provide programs or services for the District at the times and locations set forth in this Agreement.

The terms and conditions of this Agreement are as follows:

1. Dates of Service.

This Agreement shall be deemed to be effective on 04/28/2026 unless terminated earlier as provided for herein, or unless and until all obligations set forth in this Agreement have been satisfactorily fulfilled, whichever occurs first.

2. Performance.

Adela Alvarez will provide a CPR presentation on 05/04/2026 at Denfeld High School.

3. Background Check. (applies to contractors working independent with students)

Contractor must provide an executed criminal history consent form and a money order or check payable to the District in an amount equal to the actual cost of conducting a criminal history background check on all of its employees assigned to the program. Contractor is precluded from performance of contract until the results of the criminal background check(s) are on file.

If Contractor has already completed background checks for their business needs, Contractor stipulates that the background checks are completed, on file, and will be made available for review if the District should request.

Contractor will notify the District of any individual working in our schools with convictions of a gross misdemeanor or felony.

4. Reimbursement.

In consideration of the performance of Contractor of its obligations pursuant to this Agreement, District hereby agrees to reimburse Contractor for its services and expenses a sum of \$40 per person (based on actual attendance)..

Contractor is required by Minnesota Statutes, Section 270.66, subd. 3, to provide their Taxpayer Identification Number (TIN) used in the enforcement of Federal and State tax laws. The TIN will be available to Federal and State tax authorities and State personnel involved in the payment of State obligations. This Agreement will not be approved unless TIN is provided.

5. Requests for Reimbursement. The terms of payment under this Agreement are as follows:

- a. Payment shall be made by the District within 30 days of submission of a proper invoice by the Contractor;
- b. Any other terms of payment in the performance of services are incorporated by reference in this Agreement.

6. Propriety of Expenses.

The fact that the District has reimbursed Contractor for any expense claimed by Contractor shall not preclude District from questioning the propriety of any such item. District reserves the right to offset any overpayment or disallowance of any item or items at any time under this Agreement by reducing future payments to Contractor. This clause shall not be construed to bar any other legal remedies District may have to recover funds expended by Contractor for disallowed costs.

7. Ownership of Materials.

The District reserves the rights to reproduce the programming in any fashion, or appropriate the contents of the programming, or any portion thereof, to its own use for any and all programs, forms and other materials that Contractor has provided, prepared, or utilized in performance of the terms of this Agreement.

8. Independent Contractor.

Both the District and Contractor agree that they will act as an independent contractor in the performance of its duties under this Agreement. Nothing contained in this Agreement shall be construed as in any manner creating a relationship of joint venture between the parties, which shall remain independent contractors with respect to all actions performed pursuant to this Agreement.

Accordingly, Contractor shall be responsible for payment of all taxes, including Federal, State, and local taxes, arising out of Contractor's activities in accordance with this Agreement, including by way of illustration, but not limited to, Federal and State income tax, Social Security tax, Unemployment Insurance taxes, workers compensations, and any other taxes or business license fees as required.

9. Indemnity and defense of the District.

Contractor hereby agrees to defend, indemnify and hold the District harmless from all claims relating to its work pursuant to this Agreement. In the event that Contractor breaches its obligation to defend, indemnify and hold the District harmless, then in addition to its other damages the District shall be entitled to recover its attorney's fees and costs and disbursements incurred in enforcing this Agreement.

10. Notices.

All notices to be given by Contractor to District shall be deemed to have been given by depositing the same in writing in the United States Mail: ISD 709, Duluth Public

Schools, Attn: Annemarie Schilling , 709 Portia Johnson Drive, Duluth, MN 55811.
All notices to be given by District to Contractor shall be deemed to have been given by depositing the same in writing in the United States Mail to Adela Alvarez, 2816 Hagberg Street, Duluth MN 55811

11. Assignment.

Contractor shall not in any way assign or transfer any of its rights, interests or obligations under this Agreement in any way whatsoever without the prior written approval of the District.

12. Modification or Amendment.

No amendment, change or modification of this Agreement shall be valid unless in writing signed by the parties' hereto.

13. Governing Laws.

This Agreement, together with all its paragraphs, terms and provisions is made in the State of Minnesota and shall be construed and interpreted in accordance with the laws of the State of Minnesota.

14. Entire Agreement.

This Agreement contains the entire understanding of the parties hereto with respect to the subject matter hereof and shall not be changed or otherwise altered except by written agreement of the parties.

15. Cancellation.

Either party shall have the right to terminate this Agreement, without cause, upon (30) days written notice to the other party as provided for in this Agreement.

16. Data Practices.

Contractor further understands and agrees that it shall be bound by the Minnesota Government Data Practices Act (Minnesota Statutes 13.03-13.04) with respect to "data on individuals"; as defined in 13.02, subd. 5 of that Statute) which it collects, receives, stores, uses, creates or disseminates pursuant to this Agreement.

17. Insurance. (If applicable)

Contractor shall not commence work under the contract until they have obtained all the insurance described below and Duluth Public Schools has approved such insurance. Contractor shall maintain such insurance in force and effect throughout the term of the contract.

Contractor is required to maintain and furnish satisfactory evidence of the following insurance policies:

Workers' Compensation Insurance: Contractor must provide Workers' Compensation insurance for all its employees and, in case any work is subcontracted, Contractor will require the subcontractor to provide Workers' Compensation insurance in accordance with the statutory requirements of the State of Minnesota including Coverage B, Employer's Liability.

Commercial General Liability: Contractor is required to maintain insurance protecting it from claims for damages for bodily injury, including sickness or disease, death, and for care and loss of services as well as claims for property damage, including loss of use which may arise from operations under the Contract whether the operations are by the contractor or subcontractor or by anyone directly or indirectly employed under the contract.

18. Conflict of Interest and Fiduciary Duty.

All contractors doing business with the District agree to follow Policy 307 - Conflicts of Interest and Fiduciary Duty. This policy is located on the District's website.

THE REMAINDER OF THIS PAGE IS LEFT INTENTIONALLY BLANK

AS EVIDENCE OF THEIR ASSENT TO THE TERMS AND CONDITIONS OF THIS AGREEMENT, set forth above, the parties hereto have caused this Agreement to be executed by their duly authorized officers as of the day and year first above written.



 Contractor Signature SSN/Tax ID Number [REDACTED] Date 4/28/2026



 Program Director Date 4/29/2026

Please note: All signatures must be obtained AND the following must be completed by the Program Director before submission to the CFO for review and approval.

This contract is funded by either:

1. The following budget (include full 18 digit code); or
2. will be paid using Student Activity Funds; or
3. is no cost contract (e.g. Memorandum of Understanding).

Please check the appropriate line below:

Check if the contract will be paid using District funds and enter the budget code in the top line below (enter in blank spots following the example).

01	E	005	640	316	305	000
XX	X	XXX	XXX	XXX	XXX	XXX

_____ Check if the contract will be paid using Student Activity Funds

_____ Check if the contract is a no-cost contract such as a Memorandum of Understanding



 CFO / Superintendent of Schools / Board Chair Date 5/5/26

AGREEMENT

THIS AGREEMENT, made and entered into this 04/28/2026 by and between Independent School District #709, a public corporation, hereinafter called District, and Thomlin Swan, an independent contractor, hereinafter called Contractor.

THE PURPOSE OF THE AGREEMENT is to set out the terms and conditions whereby Contractor will provide programs or services for the District at the times and locations set forth in this Agreement.

The terms and conditions of this Agreement are as follows:

1. Dates of Service.

This Agreement shall be deemed to be effective on 04/28/2026 unless terminated earlier as provided for herein, or unless and until all obligations set forth in this Agreement have been satisfactorily fulfilled, whichever occurs first.

2. Performance.

Thomlin Swan will show a documentary presentation and host a question and answer session on 05/04/2026 at Denfeld High School.

3. Background Check. (applies to contractors working independent with students)

Contractor must provide an executed criminal history consent form and a money order or check payable to the District in an amount equal to the actual cost of conducting a criminal history background check on all of its employees assigned to the program. Contractor is precluded from performance of contract until the results of the criminal background check(s) are on file.

If Contractor has already completed background checks for their business needs, Contractor stipulates that the background checks are completed, on file, and will be made available for review if the District should request.

Contractor will notify the District of any individual working in our schools with convictions of a gross misdemeanor or felony.

4. Reimbursement.

In consideration of the performance of Contractor of its obligations pursuant to this Agreement, District hereby agrees to reimburse Contractor for its services and expenses a sum of \$150.

Contractor is required by Minnesota Statutes, Section 270.66, subd. 3, to provide their Taxpayer Identification Number (TIN) used in the enforcement of Federal and State tax laws. The TIN will be available to Federal and State tax authorities and State personnel involved in the payment of State obligations. This Agreement will not be approved unless TIN is provided.

5. Requests for Reimbursement. The terms of payment under this Agreement are as follows:

- a. Payment shall be made by the District within 30 days of submission of a proper invoice by the Contractor;
- b. Any other terms of payment in the performance of services are incorporated by reference in this Agreement.

6. Propriety of Expenses.

The fact that the District has reimbursed Contractor for any expense claimed by Contractor shall not preclude District from questioning the propriety of any such item. District reserves the right to offset any overpayment or disallowance of any item or items at any time under this Agreement by reducing future payments to Contractor. This clause shall not be construed to bar any other legal remedies District may have to recover funds expended by Contractor for disallowed costs.

7. Ownership of Materials.

The District reserves the rights to reproduce the programming in any fashion, or appropriate the contents of the programming, or any portion thereof, to its own use for any and all programs, forms and other materials that Contractor has provided, prepared, or utilized in performance of the terms of this Agreement.

8. Independent Contractor.

Both the District and Contractor agree that they will act as an independent contractor in the performance of its duties under this Agreement. Nothing contained in this Agreement shall be construed as in any manner creating a relationship of joint venture between the parties, which shall remain independent contractors with respect to all actions performed pursuant to this Agreement.

Accordingly, Contractor shall be responsible for payment of all taxes, including Federal, State, and local taxes, arising out of Contractor's activities in accordance with this Agreement, including by way of illustration, but not limited to, Federal and State income tax, Social Security tax, Unemployment Insurance taxes, workers compensations, and any other taxes or business license fees as required.

9. Indemnity and defense of the District.

Contractor hereby agrees to defend, indemnify and hold the District harmless from all claims relating to its work pursuant to this Agreement. In the event that Contractor breaches its obligation to defend, indemnify and hold the District harmless, then in addition to its other damages the District shall be entitled to recover its attorney's fees and costs and disbursements incurred in enforcing this Agreement.

10. Notices.

All notices to be given by Contractor to District shall be deemed to have been given by depositing the same in writing in the United States Mail: ISD 709, Duluth Public

Schools, Attn: Annemarie Schilling , 709 Portia Johnson Drive, Duluth, MN 55811.
All notices to be given by District to Contractor shall be deemed to have been given by depositing the same in writing to email thomlinswan@gmail.com

11. Assignment.

Contractor shall not in any way assign or transfer any of its rights, interests or obligations under this Agreement in any way whatsoever without the prior written approval of the District.

12. Modification or Amendment.

No amendment, change or modification of this Agreement shall be valid unless in writing signed by the parties' hereto.

13. Governing Laws.

This Agreement, together with all its paragraphs, terms and provisions is made in the State of Minnesota and shall be construed and interpreted in accordance with the laws of the State of Minnesota.

14. Entire Agreement.

This Agreement contains the entire understanding of the parties hereto with respect to the subject matter hereof and shall not be changed or otherwise altered except by written agreement of the parties.

15. Cancellation.

Either party shall have the right to terminate this Agreement, without cause, upon (30) days written notice to the other party as provided for in this Agreement.

16. Data Practices.

Contractor further understands and agrees that it shall be bound by the Minnesota Government Data Practices Act (Minnesota Statutes 13.03-13.04) with respect to "data on individuals"; as defined in 13.02, subd. 5 of that Statute) which it collects, receives, stores, uses, creates or disseminates pursuant to this Agreement.

17. Insurance. (If applicable)

Contractor shall not commence work under the contract until they have obtained all the insurance described below and Duluth Public Schools has approved such insurance. Contractor shall maintain such insurance in force and effect throughout the term of the contract.

Contractor is required to maintain and furnish satisfactory evidence of the following insurance policies:

Workers' Compensation Insurance: Contractor must provide Workers' Compensation insurance for all its employees and, in case any work is subcontracted, Contractor will require the subcontractor to provide Workers' Compensation insurance in accordance with the statutory requirements of the State of Minnesota including Coverage B, Employer's Liability.

Commercial General Liability: Contractor is required to maintain insurance protecting it from claims for damages for bodily injury, including sickness or disease, death, and for care and loss of services as well as claims for property damage, including loss of use which may arise from operations under the Contract whether the operations are by the contractor or subcontractor or by anyone directly or indirectly employed under the contract.

18. Conflict of Interest and Fiduciary Duty.

All contractors doing business with the District agree to follow Policy 307 - Conflicts of Interest and Fiduciary Duty. This policy is located on the District's website.

THE REMAINDER OF THIS PAGE IS LEFT INTENTIONALLY BLANK

AS EVIDENCE OF THEIR ASSENT TO THE TERMS AND CONDITIONS OF THIS

AGREEMENT, set forth above, the parties hereto have caused this Agreement to be executed by their duly authorized officers as of the day and year first above written.

Lindsay Swan [REDACTED] 4/29/26
 Contractor Signature SSN/Tax ID Number Date

[Signature] 4/29/2026
 Program Director Date

Please note: All signatures must be obtained AND the following must be completed by the Program Director before submission to the CFO for review and approval.

- This contract is funded by either:**
1. The following budget (include full 18 digit code); or
 2. will be paid using Student Activity Funds; or
 3. is no cost contract (e.g. Memorandum of Understanding).

Please check the appropriate line below:

X Check if the contract will be paid using District funds and enter the budget code in the top line below (enter in blank spots following the example).

01	E	005	640	316	305	000
XX	X	XXX	XXX	XXX	XXX	XXX

- Check if the contract will be paid using Student Activity Funds
- Check if the contract is a no-cost contract such as a Memorandum of Understanding

[Signature] 5/5/26
 CFO / Superintendent of Schools / Board Chair Date



INTERIORS & FLOORING

940 Apollo Road, Suite 110
Eagan, MN 55121
Ph: (651) 681-8100 Fax: (651) 681-1385

Proposal

Attn: BRYAN BROWN

From: JEFF NEYSSEN

Estimator: _____

Admin: Lauralee Blahnik

Revision #: _____

Date: 4/27/2026

Bid Due Date: 4/27/2026

Plan Date: _____

Addendum: _____

To

ISD 709 DULUTH PUBLIC SCHOOLS
709 PORTIA JOHNSON DRIVE
DULUTH, MN 55811

Phone: _____

Project

EAST HIGH SCHOOL – WEIGHT ROOMS
SWIFT # 241171
301 NORTH 40TH AVENUE EAST
DULUTH, MN 55804

Remove & Dispose of existing Vinyl Base. Supply & Install Eco Nights Rubber Interlocking Sports Tile over existing Rubber Flooring. Install new 6" Vinyl Cove Base.

TOTAL (APPLICABLE TAX INCLUDED) \$ 43,415.00

Notes –

Proposal based on work performed during regular business hours (no overtime)

Proposal includes minor Floor Prep for installation of new Rubber Flooring, additional Prep if discovered necessary, will be Billed on a Time & Material basis.

Handwritten notes:
1. 13
2. 24

****CFS Interiors & Flooring will not be held responsible for any delays related to supply-chain issues or labor shortages.****

These delays are beyond our control, therefore CPS will not accept any back-charges or liquidated damages at this time. The construction industry is experiencing frequent and prolonged delays from both manufacturing and shipping companies. Please take these issues into account when placing orders or scheduling your projects. Physical samples for submittals may take in excess of 14 business days to process. Consider processing digital submittals whenever possible.

Commercial Flooring Services, LLC will furnish, deliver, and install the above material in accordance with all transmitted plans, specifications and general conditions for the listed price. The price includes all applicable freight and taxes, unless otherwise noted. Unless specifically included in this proposal: excludes all demolition, repair or take-up of existing flooring; excludes vacuuming, damp mopping, buffing, waxing or floor protection; excludes floor floating, leveling or repair; excludes sealing of floor, cleaning or removal of oil, grease, solvents, paints, plaster or other foreign substances; excludes asbestos control/abatement; includes no site stock of material beyond installation coverage; includes work only during regular hours and for a single phase job; excludes any furniture movement; excludes any addenda beyond the base bid; Per CRF-104-96, 8.3 site conditions: The owner or general contractor must submit to the flooring contractor a written report on moisture and surface alkalinity of the slab to determine its suitability as a substrate for the material to be installed. Floor preparation will be billed on a time and material basis at the current rate per man-hour plus the cost of the materials. Client is subject to payment for stored materials. Commercial Flooring Services, LLC will not accept charge backs of damage or cleaning without the option to inspect claim(s) to repair or without the option to make arrangements for acceptable repairs at their expense. Commercial Flooring Services, LLC is not responsible for any claims that might result from product delivery date changes beyond their control. If a manufacturer requires a deposit to manufacture/ship certain items, client will pay that amount. This proposal is valid for thirty (30) days. Full payment is due ten (10) days from receipt of invoice unless otherwise specified.

WARRANTY DOES NOT INCLUDE ANY MOISTURE RELATED SUBFLOOR FAILURES

1. P&I (PRODUCT & INSTALLATION)

ISD 709 DULUTH PUBLIC SCHOOLS *PS-B*

Signed: 
JEFF NEYSSEN

Signed: _____

Proposal Total: \$43,415.00

Proposed Installation Start Date: 7/1/2025

Ernie Zwick 4.28.26

Memorandum

To: Simone Zunich, Executive Director of Business Services
School Board Members

From: Bryan Brown
Manager of Facilities

Date: April 15, 2026

Re: Annual Quotes for District Wide Contract Services

The following RFPs are for services to be performed from July 1, 2026 through June 30, 2027, with the option to renew for two (2) additional one-year periods if acceptable to both parties.

RFP #342 – District-Wide Annual Bricklayer Labor

Stretar Masonry & Concrete - Total Annual cost estimated at \$65,200.00

RFP #343 – District-Wide Annual Elevator Service

Larson Elevator Company – Total Annual Cost estimated at \$41,900.00

RFP #344 – District-Wide Annual Service & Maintenance of Emergency Generators

Hunt Electric – Total Annual Cost estimated at \$7,418.29

RFP #345 – District-Wide Annual Painting Labor

Regional Contracting & Painting – Total Annual Cost estimated at \$44,622.00

RFP #346 – District-Wide Annual Plumbing Labor Services

The Jamar Company – Total Annual Cost estimated at \$74,000.00

RFP #347 – District-Wide Annual Roofing Labor

A.W. Kuettel & Sons, Inc. – Total Annual Cost estimated at \$60,150.00

The Facilities Department, Bryan Brown and Heather Morberg reviewed the bids.

Recommendation

I recommend the Duluth School Board approve entering into a contract with each contractor based on their low quote. A quote tabulation is attached for each quote for your reference. If you concur, please sign all copies of the attached agreements.

Program: Facilities

Fund Custodian: Bryan Brown Facilities

Attachments

Memorandum

To: Simone Zurich, Executive Director of Business Services
School Board Members

From: Bryan Brown
Manager of Facilities

Date: April 15, 2026

Re: Annual Quotes for District Wide Contract Services

The following RFPs are for services to be performed from July 1, 2026 through June 30, 2027, with the option to renew for two (2) additional one-year periods if acceptable to both parties.

RFP #342 – District-Wide Annual Bricklayer Labor
Stretar Masonry & Concrete - Total Annual cost estimated at \$65,200.00

RFP #343 – District-Wide Annual Elevator Service
Larson Elevator Company – Total Annual Cost estimated at \$41,900.00

RFP #344 – District-Wide Annual Service & Maintenance of Emergency Generators
Hunt Electric – Total Annual Cost estimated at \$7,418.29

RFP #345 – District-Wide Annual Painting Labor
Regional Contracting & Painting – Total Annual Cost estimated at \$44,622.00

RFP #346 – District-Wide Annual Plumbing Labor Services
The Jamar Company – Total Annual Cost estimated at \$74,000.00

RFP #347 – District-Wide Annual Roofing Labor
A.W. Kuettel & Sons, Inc. – Total Annual Cost estimated at \$60,150.00

The Facilities Department, Bryan Brown and Heather Morberg reviewed the bids.

Recommendation

I recommend the Duluth School Board approve entering into a contract with each contractor based on their low quote. A quote tabulation is attached for each quote for your reference. If you concur, please sign all copies of the attached agreements.

Program: Facilities

Fund Custodian: Bryan Brown Facilities

Attachments

BID TABULATION

ANNUAL ELEVATOR SERVICE

for the period of July 1, 2026 through June 30, 2027

RF# 4343

Wednesday, April 15, 2026, 10:15 a.m.

ELEVATOR SERVICE/TESTING	MEI - Total Elevator Solutions			All City Elevator			Larsen Elevator Company		
	regular	overtime	holiday	regular	overtime	holiday	regular	overtime	holiday
1 Congdon Park ES	\$729.88			\$1,134.00					
2 Congdon Park ES - Lift	\$469.31			\$1,134.00					
3 Denfield HS	\$729.86			\$1,134.00					
4 Denfield HS	\$729.86			\$1,134.00					
5 East HS	\$729.86			\$1,134.00					
6 Homestead ES	\$729.86			\$1,134.00					
7 Laura MacArthur ES	\$729.86			\$1,134.00					
8 Laura MacArthur ES	\$729.86			\$1,134.00					
9 Lester Park ES	\$729.86			\$1,134.00					
10 Lincoln Park MS	\$729.86			\$1,134.00					
11 Mayers Wilkins ES	\$729.86			\$1,134.00					
12 Orlean East MS - South	\$729.86			\$1,134.00					
13 Orlean East MS - North	\$729.86			\$1,134.00					
14 Piedmont ES	\$729.86			\$1,134.00					
15 DSC Administration Building	\$707.25			\$1,134.00					
Total Annual Amount of Service/Tras	\$10,665.00			\$17,010.00					\$12,240.00
HOURLY SERVICES									
Mechanic in Charge	\$284.00	\$336.00	\$351.00	\$255.00	\$450.00	\$550.00	\$225.00	\$382.50	\$450.00
Mechanic	\$186.00	\$207.00	\$207.00	\$200.00	\$383.00	\$450.00	\$175.00	\$297.50	\$356.00
Apprentice 4th Year	\$186.00	\$207.00	\$207.00	\$200.00	\$383.00	\$450.00	\$86.00	\$146.30	\$172.00
Apprentice 3rd Year	\$186.00	\$207.00	\$207.00	\$200.00	\$383.00	\$450.00	\$83.00	\$141.10	\$168.00
Apprentice 2nd Year	\$186.00	\$207.00	\$207.00	\$200.00	\$383.00	\$450.00	\$76.00	\$129.30	\$152.00
Apprentice 1st Year	\$186.00	\$207.00	\$207.00	\$200.00	\$383.00	\$450.00	\$73.00	\$124.10	\$146.00
Probation Apprentice	\$186.00	\$207.00	\$207.00	\$200.00	\$383.00	\$450.00	\$78.00	\$119.00	\$140.00
Helper	\$186.00	\$207.00	\$207.00	\$200.00	\$383.00	\$450.00	\$78.00	\$119.00	\$140.00
Total Amount of Labor	\$50,720.00			\$45,500.00			\$29,660.00		
TOTAL ANNUAL AMOUNT OF BID	\$61,385.00			\$62,510.00			\$41,900.00		

Memorandum

To: Simone Zunich, Executive Director of Business Services
School Board Members

From: Bryan Brown
Manager of Facilities

Date: April 15, 2026

Re: Annual Quotes for District Wide Contract Services

The following RFPs are for services to be performed from July 1, 2026 through June 30, 2027, with the option to renew for two (2) additional one-year periods if acceptable to both parties.

RFP #342 – District-Wide Annual Bricklayer Labor
Stretar Masonry & Concrete - Total Annual cost estimated at \$65,200.00

RFP #343 – District-Wide Annual Elevator Service
Larson Elevator Company – Total Annual Cost estimated at \$41,900.00

RFP #344 – District-Wide Annual Service & Maintenance of Emergency Generators
Hunt Electric – Total Annual Cost estimated at \$7,418.29

RFP #345 – District-Wide Annual Painting Labor
Regional Contracting & Painting – Total Annual Cost estimated at \$44,622.00

RFP #346 – District-Wide Annual Plumbing Labor Services
The Jamar Company – Total Annual Cost estimated at \$74,000.00

RFP #347 – District-Wide Annual Roofing Labor
A.W. Kuettel & Sons, Inc. – Total Annual Cost estimated at \$60,150.00

The Facilities Department, Bryan Brown and Heather Morberg reviewed the bids.

Recommendation

I recommend the Duluth School Board approve entering into a contract with each contractor based on their low quote. A quote tabulation is attached for each quote for your reference. If you concur, please sign all copies of the attached agreements.

Program: Facilities

Fund Custodian: Bryan Brown Facilities

Attachments

QUOTE TABULATION
ANNUAL SERVICE AND MAINTENANCE OF EMERGENCY GENERATORS
for the period of July 1, 2026 through June 30, 2027

RFP #344

Wednesday, April 15, 2026, 10:30 a.m.

		Wescom Inc.	Hunt Electric	Interstate PowerSystems	Lighthouse Power
1	Congdon Park		\$436.37	\$718.60	
2	Denfield HS		\$436.37	\$718.60	
3	East HS		\$436.37	\$718.60	
4	Homecroft		\$436.37	\$718.98	
5	Lakewood		\$436.37	\$788.40	
6	Laura MacArthur		\$436.37	\$734.01	
7	Lester Park		\$436.37	\$734.01	
8	Lincoln Park MS		\$436.37	\$879.10	
9	Lowell		\$436.37	\$743.19	
10	Myers-Wilkins		\$436.37	\$718.60	
11	Ordean East MS		\$436.37	\$894.51	
12	Piedmont		\$436.37	\$734.01	
13	Rockridge		\$436.37	\$687.59	
14	Stowe		\$436.37	\$770.83	
15	Facilities		\$436.37	\$700.64	
16	Transportation		\$436.37	\$700.64	
17	DSC Administration		\$436.37	\$700.64	
TOTAL ANNUAL AMOUNT		No Bid	\$7,418.29	\$12,660.97	No Bid
ADDITIONAL WORK AND EMERGENCY SERVICES HOURLY RATE					
	Normal Working Hours		\$136.40	\$175.00	
	After Normal Working Hours		\$204.06	\$262.50	
	Sunday/Holiday Working Hours		\$271.71	\$350.00	
	Factory Trained Personnel		Generac	All	

Memorandum

To: Simone Zunich, Executive Director of Business Services
School Board Members

From: Bryan Brown
Manager of Facilities

Date: April 15, 2026

Re: Annual Quotes for District Wide Contract Services

The following RFPs are for services to be performed from July 1, 2026 through June 30, 2027, with the option to renew for two (2) additional one-year periods if acceptable to both parties.

RFP #342 – District-Wide Annual Bricklayer Labor

Stretar Masonry & Concrete - Total Annual cost estimated at \$65,200.00

RFP #343 – District-Wide Annual Elevator Service

Larson Elevator Company – Total Annual Cost estimated at \$41,900.00

RFP #344 – District-Wide Annual Service & Maintenance of Emergency Generators

Hunt Electric – Total Annual Cost estimated at \$7,418.29

RFP #345 – District-Wide Annual Painting Labor

Regional Contracting & Painting – Total Annual Cost estimated at \$44,622.00

RFP #346 – District-Wide Annual Plumbing Labor Services

The Jamar Company – Total Annual Cost estimated at \$74,000.00

RFP #347 – District-Wide Annual Roofing Labor

A.W. Kuettel & Sons, Inc. – Total Annual Cost estimated at \$60,150.00

The Facilities Department, Bryan Brown and Heather Morberg reviewed the bids.

Recommendation

I recommend the Duluth School Board approve entering into a contract with each contractor based on their low quote. A quote tabulation is attached for each quote for your reference. If you concur, please sign all copies of the attached agreements.

Program: Facilities

Fund Custodian: Bryan Brown Facilities

Attachments

**BID TABULATION
PAINTING LABOR**

for the period of July 1, 2026 through June 30, 2027
RFP #345

Wednesday, April 15, 2026 - 10:45 a.m.

Vendor	Painter		Drywall Taper		Plasterers		Total Annual Hourly Bid (500 hrs)
	Foreman regular hourly rate overtime hourly rate	Apprentice regular hourly rate overtime hourly rate	Journeyman regular hourly rate overtime hourly rate	Apprentice regular hourly rate overtime hourly rate	Journeyman regular hourly rate overtime hourly rate		
Lakehead Painting Company, Inc. 910 Hammond Avenue Superior, Wisconsin 54880 phone: 715-394-5799							No Bid
Northland Painting of Duluth 5506 Thompson Hill Road Duluth, Minnesota 55810 phone: 218-348-1327							No Bid
Calco Painting 5904 McQuade Rd Duluth, MN 55804 phone: 218-525-2137							No Bid
Regional Contracting & Painting PO Box 16661 Duluth, Minnesota 55816 phone: 218-341-4683	regular hourly rate \$98.86 overtime hourly rate \$118.63	regular hourly rate \$80.00 overtime hourly rate \$108.00	regular hourly rate \$96.36 overtime hourly rate \$115.63	regular hourly rate \$78.00 overtime hourly rate \$105.30	regular hourly rate \$93.00 overtime hourly rate \$111.60		\$44,622.00
Steinbrecher Painting, Inc. 1408 7th Street North Princeton, Minnesota 55371 phone: 763-389-3887							No Bid
Swanson & Youngdale, Inc. 3905 Prosperity Road Duluth, Minnesota 55811 phone: 218-727-6682							No Bid

Memorandum

To: Simone Zunich, Executive Director of Business Services
School Board Members

From: Bryan Brown
Manager of Facilities

Date: April 15, 2026

Re: Annual Quotes for District Wide Contract Services

The following RFPs are for services to be performed from July 1, 2026 through June 30, 2027, with the option to renew for two (2) additional one-year periods if acceptable to both parties.

RFP #342 – District-Wide Annual Bricklayer Labor

Stretar Masonry & Concrete - Total Annual cost estimated at \$65,200.00

RFP #343 – District-Wide Annual Elevator Service

Larson Elevator Company – Total Annual Cost estimated at \$41,900.00

RFP #344 – District-Wide Annual Service & Maintenance of Emergency Generators

Hunt Electric – Total Annual Cost estimated at \$7,418.29

RFP #345 – District-Wide Annual Painting Labor

Regional Contracting & Painting – Total Annual Cost estimated at \$44,622.00

RFP #346 – District-Wide Annual Plumbing Labor Services

The Jamar Company – Total Annual Cost estimated at \$74,000.00

RFP #347 – District-Wide Annual Roofing Labor

A.W. Kuettel & Sons, Inc. – Total Annual Cost estimated at \$60,150.00

The Facilities Department, Bryan Brown and Heather Morberg reviewed the bids.

Recommendation

I recommend the Duluth School Board approve entering into a contract with each contractor based on their low quote. A quote tabulation is attached for each quote for your reference. If you concur, please sign all copies of the attached agreements.

Program: Facilities

Fund Custodian: Bryan Brown Facilities

Attachments

**BID TABULATION
PLUMBING LABOR**

for the period of July 1, 2026 through June 30, 2027
RFP #346

Wednesday, April 15, 2026 - 11:00 a.m.

Vendor	PLUMBER Hourly Rates			SHEET METAL Hourly Rates			INSULATOR Hourly Rates			Total Annual Amount of Bid	
	Hourly Rate	Foreman	Journeyman	Apprentice	Foreman	Journeyman	Apprentice	Foreman	Journeyman		Apprentice
A.G. O'Brien Plumbing/Heating Co. 4907 Lighting Drive Duluth, Minnesota 55811	Regular Total Annual Overtime										No Bid
A.W. Kuettel & Sons, Inc. 3930 Alpark Boulevard Duluth, Minnesota 55811	Regular Total Annual Overtime										No Bid
Carlson Brothers Mechanical 2502 West Huron Street Duluth, Minnesota 55806	Regular Total Annual Overtime										No Bid
Carlson Duluth Company 2901 Helm Street Duluth, Minnesota 55806	Regular Total Annual Overtime										No Bid
General Heating & Mechanical 1922 West Superior Street Duluth, Minnesota 55806	Regular Total Annual Overtime										No Bid
The Jamar Company 4701 Mike Colalillo Drive Duluth, Minnesota 55807	Regular Total Annual Overtime	\$166.00 \$16,000.00 \$240.00	\$120.00 \$12,000.00 \$180.00	\$90.00 \$9,000.00 \$135.00	\$160.00 \$8,000.00 \$240.00	\$120.00 \$6,000.00 \$180.00	\$90.00 \$4,500.00 \$135.00	\$160.00 \$8,000.00 \$240.00	\$120.00 \$6,000.00 \$180.00	\$90.00 \$4,500.00 \$135.00	\$74,000.00

Memorandum

To: Simone Zunich, Executive Director of Business Services
School Board Members

From: Bryan Brown
Manager of Facilities

Date: April 15, 2026

Re: Annual Quotes for District Wide Contract Services

The following RFPs are for services to be performed from July 1, 2026 through June 30, 2027, with the option to renew for two (2) additional one-year periods if acceptable to both parties.

RFP #342 – District-Wide Annual Bricklayer Labor
Stretar Masonry & Concrete - Total Annual cost estimated at \$65,200.00

RFP #343 – District-Wide Annual Elevator Service
Larson Elevator Company – Total Annual Cost estimated at \$41,900.00

RFP #344 – District-Wide Annual Service & Maintenance of Emergency Generators
Hunt Electric – Total Annual Cost estimated at \$7,418.29

RFP #345 – District-Wide Annual Painting Labor
Regional Contracting & Painting – Total Annual Cost estimated at \$44,622.00

RFP #346 – District-Wide Annual Plumbing Labor Services
The Jamar Company – Total Annual Cost estimated at \$74,000.00

RFP #347 – District-Wide Annual Roofing Labor
A.W. Kuettel & Sons, Inc. – Total Annual Cost estimated at \$60,150.00

The Facilities Department, Bryan Brown and Heather Morberg reviewed the bids.

Recommendation

I recommend the Duluth School Board approve entering into a contract with each contractor based on their low quote. A quote tabulation is attached for each quote for your reference. If you concur, please sign all copies of the attached agreements.

Program: Facilities

Fund Custodian: Bryan Brown Facilities

Attachments

**BID TABULATION
ROOFING LABOR**

for the period of July 1, 2026 through June 30, 2027
RFP #347

Wednesday, April 15, 2026 - 11:15 a.m.

Vendor	Hourly Rate	ROOFING Hourly Rates				Cranal Operator (55)	SHEET METAL Hourly Rates			Total Annual Amount of Bid
		Foreman	Journeyman	Apprentice	Laborer		Foreman	Journeyman	Apprentice	
A. W. Kuettel & Sons, Inc.	regular	\$110.00	\$100.00	\$75.00	\$65.00	\$190.00	\$115.00	\$110.00	\$88.00	
3930 Airpark Boulevard	total annual	\$11,000.00	\$10,000.00	\$7,500.00	\$6,500.00	\$9,500.00	\$5,750.00	\$5,500.00	\$4,400.00	\$60,150.00
Duluth, Minnesota 55811	overtime	\$133.00	\$122.00	\$100.00	\$90.00	\$245.00	\$140.00	\$133.00	\$100.00	
Commercial Roofing, Inc.	regular	\$120.00	\$117.00	\$95.00	\$95.00	\$140.00	\$130.00	\$127.00	\$119.00	
P.O. Box 167	total annual	\$12,000.00	\$11,700.00	\$9,500.00	\$9,500.00	\$7,000.00	\$6,500.00	\$6,350.00	\$5,950.00	\$68,500.00
Barnum, Minnesota 55707	overtime	\$132.00	\$128.00	\$105.00	\$105.00	\$159.00	\$150.00	\$146.00	\$128.00	
The Jamar Company	regular	\$135.00	\$115.00	\$90.00	\$90.00	\$190.00	\$135.00	\$115.00	\$90.00	
4701 Mike Colalillo Drive	total annual	\$13,500.00	\$11,500.00	\$9,000.00	\$9,000.00	\$9,500.00	\$6,750.00	\$5,750.00	\$4,500.00	\$69,500.00
Duluth, Minnesota 55807	overtime	\$202.50	\$172.50	\$135.00	\$135.00	\$285.00	\$202.50	\$172.50	\$135.00	
Ed Oman Construction	regular									
5092 Howard Gnesen Road	total annual									No Bid
Duluth, MN 55803	overtime									
C Binsfield Construction Inc.	regular									
1920 E 5th Street	total annual									No Bid
Duluth, MN 55812	overtime									
	regular									
	total annual									
	overtime									

Memorandum

To: Simone Zunich, Executive Director of Business Services
School Board Members

From: Bryan Brown
Manager of Facilities

Date: April 30, 2026

Re: Annual Quote for District Wide Contract Services

The following RFP is for services to be performed from July 1, 2026 through June 30, 2027, with the option to renew for four (4) additional one-year periods if acceptable to both parties.

RFP #348 – District-Wide Security System and Fire Detection Monitoring Services
Per Mar Security - Total Annual cost estimated at \$47,033.64

The Facilities Department, Bryan Brown, Heather Morberg, and Kris Brown reviewed the bids.

Recommendation

I recommend the Duluth School Board approve entering into a contract with this contractor based on their low quote. A quote tabulation is attached for your reference. If you concur, please sign the copy of the attached agreement.

Program: Facilities

Fund Custodian: Bryan Brown Facilities

Attachment

QUOTE TABULATION
SECURITY SYSTEM AND FIRE DETECTION MONITORING SERVICES

for the period of July 1, 2026 through June 30, 2027
RFP #348

Wednesday, April 15, 2026, 11:30 a.m.

	ARS-Arrowhead Radio and Security	Security 101	Per Mar Security
1	Congdon Park ES		\$253.09
2	Denfield HS		\$253.09
3	East HS		\$253.09
4	Laura MacArthur ES		\$253.09
5	Lester Park ES		\$261.95
6	Lincoln Park ES		\$261.95
7	Myers-Wilkins ES		\$261.95
8	Orlean East MS		\$261.95
9	Piedmont ES		\$261.95
10	Rockridge Academy		\$248.53
11	First Street Building/DNT		TBD
12	Homecroft ES		\$253.09
13	Lakewood ES		\$244.23
14	Lowell ES		\$244.23
15	DSC		\$123.27
16	Facilities		\$116.51
17	Stowe ES		\$244.23
18	Transportation Center		\$123.27
TOTAL MONTHLY AMOUNT			\$3,919.47
TOTAL ANNUAL AMOUNT OF QUOTE			No Bid No Bid \$47,033.64

SERVICE TECHNICIAN (for repair of non-vendor owned equipment)

Normal Working Hours		\$176.00
After Normal Working Hours including Saturday		\$264.00
Sunday and Holiday Working Hours		\$264.00



**AMENDMENT TWO
EXTENSION OF TERM**

This Amendment ("Amendment Two"), between Kelly Services, Inc. ("Kelly"), with its principal offices located at 3001 Metro Drive, Suite 200, Bloomington, MN 55425, and Duluth Public Schools ("Customer"), is for the purpose of extending the term of their Agreement.

RECITALS

- A. Kelly and Customer entered into Agreement Renewal ("Agreement"), dated July 1, 2024.
- B. The term of the Agreement expires on June 30, 2026.
- C. Kelly and Customer wish to modify the Agreement to extend the term of the Agreement, as set forth below.

AGREEMENT

Kelly and Customer therefore agree as follows:

- 1. **Extension of Term.** The term of the Agreement will continue in effect unless cancelled by either party upon allowing not less than ninety (90) days prior written notice to the other party.
- 2. **Miscellaneous.** This Amendment will become effective when both parties have signed it. The date on which the last party has signed this Amendment (as indicated by the date associated with that party's signature) will be deemed the date of this Amendment. Kelly and Customer restate all other provisions of the Agreement and agree that all such provisions remain in effect. To the extent there is a conflict between this Amendment Two and the Agreement, the terms of Amendment Two will control.

Kelly Services, Inc.

Signature: Jennifer Lile
 Name: Jennifer Lile
 Title: Vice President, Client Services
 Date: 06-May-2026 | 9:00 AM PDT

Duluth Public Schools

Signature: Suzanne Zunicke
 Name: Suzanne Zunicke
 Title: Exec. Dir. Finance, Business Services
 Date: 5/5/26

Service Order



PREPARED FOR:

Account Name Independent School District No. 709 a/k/a Duluth Public Schools

Contact Name Greg Krueger
Billing Address 709 Portia Johnson Dr, Duluth, Minnesota, 55811

Contract Term 60 months
Account Number 0000004954

SERVICE ORDER # Q-14321

Proposal Name Independent School District No. 709 a/k/a Duluth Public Scho[]Colo 2 Rack Renewal Opportunity
Date 4/24/2026

Account Manager Dom Ciavolella
Phone
Email dciavolella@arkdna.com

Effective as of the Service Start Date (defined below), this Service Order # Q-14321 terminates, replaces, and supersedes Service Order(s) as amended from time to time # Q-08465, in its entirety (the "Service Order").

I. SERVICES:

Monthly Recurring Services

QTY	Product Name	Product Code	Specifications	UNIT PRICE	EXT PRICE
6.00	SecurePower Colocation	INV-COLO-All-In-Duluth Tech Drive	Sold per kW, includes N+1 power delivery, cabinet spaces, and fixed power expense.	\$360.43	\$2,162.58
2.00	Fiber Pair Cross Connect	INV-XCON-FP-Duluth Tech Drive		\$195.00	\$390.00
Monthly Recurring Services TOTAL:					\$2,552.58

USAGE CHARGES ABOVE COMMITTED AMOUNT, if any:

II. DESCRIPTION OF IMPLEMENTATION REQUIREMENTS, IF ANY, WHICH SHALL NOT BE AN AMENDMENT TO THE DESCRIPTION OF SERVICES:

A. Summary Overview of Services, if any:

B. Projected number of days from Effective Date on which Services listed are expected to begin, if different than the table in Section III below:

III. PROJECTED SERVICE START DATE:

This Service Order is a renewal of existing Services. The Term shall begin on 5/1/2026 (the "Service Start Date").

IV. TERM and TERMINATION:

A. This Service Order is made effective as of the last date shown in the signature block below (the "Effective Date") and shall continue until the earlier of the end of the Term (defined below), or termination in accordance with the terms of the Master Services Agreement, dated as of 5/23/2013, entered into between the Parties (as amended, the "MSA").

B. The Services will begin on the Service Start Date, and unless terminated earlier as provided in this Service Order, will continue through the completion of that period of time stated above as the Contract Term (the "Initial Term").

C. Unless terminated earlier as provided herein, upon expiration of the Initial Term, this Service Order shall automatically renew for successive one (1) year terms on the same terms and conditions as set forth herein, with Monthly Recurring Service Charges adjusted to Ark's then-current list prices, rates and fees, available upon request (each a "Renewal Term," and together with the Initial Term, referred to collectively as the "Term").

D. Either Party may terminate this Service Order at the end of the Initial Term by providing written notice to the other at least ninety (90) days prior to the end of the Initial Term. Either Party may terminate this Service Order at the end of any Renewal Term by providing written notice to the other at least thirty (30) days prior to the end of any Renewal Term. Either Party may terminate this Service Order: (a) upon thirty (30) days written notice, or five (5) days in the event of non-payment of Service Charges, to the other Party of the other Party's material breach of the Agreement or this Service Order, provided that such material breach is not cured within such thirty (30) day or such five (5) day period; or (b) immediately, in the event that the other Party liquidates, is adjudicated as bankrupt, makes an assignment for the benefit of creditors, invokes any provision of law for general relief from its debtors, initiates any proceeding seeking general protection from its creditors, or is removed or delisted from a trading exchange (any such termination described in clause (a) or (b), a termination for "Cause"). Ark additionally has the right terminate Service(s) in the event that, after entering into this Service Order, Ark, in its sole discretion, determines it is unable to accommodate or provide the Service(s).

E. In the event Client terminates this Service Order for any reason other than for Cause, Client shall promptly pay Ark the full amount of the Monthly Recurring Service Charges that Client would have been charged for the remainder of the Initial Term or the then-current Renewal Term, reimburse Ark for all volume, Term or other discounts, rebates, promotions, and credits provided in anticipation of full performance of Client's obligations and any unpaid portion of any installation fee set forth in this Service Order, and reimburse Ark for any third-party costs associated with the terminated Service(s).# If Ark terminates this Service Order without Cause, Ark will refund any pre-paid monies on a pro-rated basis for Services not rendered.

V. INVOICING; PAYMENT TERMS:

- A. *Invoicing.* Except as expressly provided Section II above, Ark shall invoice Client as follows:
- i. Monthly Recurring Service Charges shall be invoiced beginning immediately after the Service Start Date;
 - ii. Non-Recurring Service Charges shall be invoiced upon the Effective Date; and
 - iii. Hardware shall be invoiced when shipped.
- B. *Payment Terms.* Client shall pay all Monthly Recurring Service Charges monthly in advance, within fifteen (15) days after the date on each invoice, for each Service, from the Service Start Date through the end of Term.# Client shall pay all other fees and charges within fifteen (15) days after the date on each invoice. All taxes and governmental fees and charges, if applicable, are not included in the above referenced pricing.

VI. TERMS & CONDITIONS:

- A. This Service Order is incorporated into and made a part of the MSA. Capitalized terms used but not defined in this Service Order have the meanings given to such terms in the MSA. The Ark Terms and Conditions (the "Terms & Conditions") as found at <https://www.arkdna.com/terms/> are incorporated herein by this reference.
- B. Product Codes in the table in Section I above are defined in the applicable Service Description(s), available at sd.arkdna.com (each, a "Service Description"), which are incorporated herein by this reference.
- C. Any number of hours set forth in the table in Section I above under the "QTY" heading are an estimate only, based on the information provided to Ark by Client as of the Effective Date. In the event information changes, or new information becomes available, the estimate of hours may not be sufficient to complete the applicable project. Notwithstanding anything to the contrary herein, Client agrees to pay Ark for the actual hours expended by Ark in performance of the Services.
- D. If there is a conflict between the "Specifications" (as set forth in the table in Section I) and a Service Description, the Service Description shall govern and control.

VII. SUPPLEMENTAL SERVICES:

- A. Ark will provide services outside the scope of this Service Order on a time plus materials and expenses basis (a) when requested and authorized by the Authorized Client Representative during Normal Business Hours (defined below); and/or (b) when requested and authorized by any agent

of Client outside Normal Business Hours. "Normal Business Hours" shall mean 8:00AM to 5:00PM local time, Mondays through Fridays, exclusive of holidays. For all work performed outside the scope of this Service Order, Ark shall prepare and submit invoices to Client on the 15th and last business day of each month. Service Charges will be based on the then-current Ark IT Services Rate Card ("Standard Rates") plus travel expenses (if services are provided other than inside the data center) and any applicable sales tax. Standard Rates are from 8:00AM to 5:00PM local time. Service Charges for nights and weekends are 1.5 times Standard Rates, and holidays are two (2) times Standard Rates.

B. Travel expenses are billed at actual cost and mileage at the current IRS rate, portal to portal. Travel expenses include applicable lodging, meals, airfare, and car rental.

VIII. CONFIDENTIALITY:

Client agrees that this Service Order, including without limitation the description of services and the pricing, is the sole and exclusive property of Ark, and shall treat them as Confidential Information pursuant to the terms of the MSA or any confidentiality agreement between the Parties, or if none, under and as defined in the non-disclosure terms & conditions found at <https://www.arkdna.com/nda/>.

IX. ACCEPTANCE:

Each of the undersigned represents that the undersigned has (i) read and understands this Service Order and has full power and authority to sign it, and (ii) agrees and acknowledges that this Service Order is governed by and incorporated into the MSA.

***** Remainder of Page Left Blank Intentionally - Signature Page to Follow *****

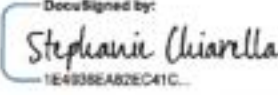
Client (legal name): Independent School District No. 709 a/k/a Duluth Public Schools	ark data centers, LLC
Individual signing: Simone Zurich	Individual signing: Stephanie Chiarella
Signature:  <p>Signed by: Simone Zurich ED8A9815704094DE...</p>	Signature:  <p>DocuSigned by: Stephanie Chiarella 1E4938EA82EC41C...</p>
Title: Exec Director of BS Services	Title: CFO
Signing Date: 4/29/2026	Signing Date: 4/30/2026
Purchase Order #:	
Email (for Notice of Service Start Date):	

Service Order



PREPARED FOR:

Account Name Independent School
District No. 709 a/k/a
Duluth Public Schools

Contact Name Greg Krueger
Billing Address 709 Portia Johnson Dr,
Duluth,
Minnesota,
55811

Contract Term 1 month
Account Number 0000004954

SERVICE ORDER # Q-14358

Proposal Name Independent School
District No. 709 a/k/a
Duluth Public Scho[
]Cross Connect - M2M
renewal
Date 4/30/2026

Account Manager Kevin Avenius
Phone
Email kavenius@arkdna.com

I. SERVICES:

Monthly Recurring Service Charges

QTY	Product Name	Product Code	Specifications	UNIT PRICE	EXT PRICE
3.00	Fiber Pair Cross Connect	INV-XCON-FP-Duluth Tech Drive	1-pair fiber cross connect within the designated data center.	\$225.00	\$675.00
Monthly Recurring Service Charges TOTAL:					\$675.00

USAGE CHARGES ABOVE COMMITTED AMOUNT, if any:

II. DESCRIPTION OF IMPLEMENTATION REQUIREMENTS, IF ANY, WHICH SHALL NOT BE AN AMENDMENT TO THE DESCRIPTION OF SERVICES:

A. Summary Overview of Services, if any:

B. Projected number of days from Effective Date on which Services listed are expected to begin, if different than the table in Section III below:

III. PROJECTED SERVICE START DATE:

This Service Order is a renewal of existing Services. The Term shall begin on 5/1/2026 (the "Service Start Date").

IV. TERM and TERMINATION:

A. This Service Order is made effective as of the last date shown in the signature block below (the "Effective Date") and shall continue until the earlier of the end of the Term (defined below), or termination in accordance with the terms of the Master Services Agreement, dated as of 5/23/2013, entered into between the Parties (as amended, the "MSA").

B. The Services will begin on the Service Start Date, and unless terminated earlier as provided in this Service Order, will continue through the completion of that period of time stated above as the Contract Term (the "Initial Term").

C. Unless terminated earlier as provided herein, upon expiration of the Initial Term, this Service Order shall automatically renew on a month-to-month basis on the same terms and conditions as set forth herein, with Monthly Recurring Service Charges adjusted to Ark's then-current list prices, rates and fees, available upon request (each a "Renewal Term," and together with the Initial Term, referred to collectively as the "Term").

D. Either Party may terminate this Service Order at the end of the Initial Term by providing written notice to the other at least thirty (30) days prior to the end of the Initial Term. Either Party may terminate this Service Order at the end of any Renewal Term by providing written notice to the other at least thirty (30) days prior to the end of any Renewal Term. Either Party may terminate this Service Order: (a) upon thirty (30) days written notice, or five (5) days in the event of non-payment of Service Charges, to the other Party of the other Party's material breach of the Agreement or this Service Order, provided that such material breach is not cured within such thirty (30) day or such five (5) day period; or (b) immediately, in the event that the other Party liquidates, is adjudicated as bankrupt, makes an assignment for the benefit of creditors, invokes any provision of law for general relief from its debtors, initiates any proceeding seeking general protection from its creditors, or is removed or delisted from a trading exchange (any such termination described in clause (a) or (b), a termination for "Cause"). Ark additionally has the right terminate Service(s) in the event that, after entering into this Service Order, Ark, in its sole discretion, determines it is unable to accommodate or provide the Service(s).

E. In the event Client terminates this Service Order for any reason other than for Cause, Client shall promptly pay Ark the full amount of the Monthly Recurring Service Charges that Client would have been charged for the remainder of the Initial Term or the then-current Renewal Term, reimburse Ark for all volume, Term or other discounts, rebates, promotions, and credits provided in anticipation of full performance of Client's obligations and any unpaid portion of any installation fee set forth in this Service Order, and reimburse Ark for any third-party costs associated with the terminated Service(s). If Ark terminates this Service Order without Cause, Ark will refund any pre-paid monies on a pro-rated basis for Services not rendered.

V. INVOICING; PAYMENT TERMS:

- A. *Invoicing.* Except as expressly provided Section II above, Ark shall invoice Client as follows:
- i. Monthly Recurring Service Charges shall be invoiced beginning immediately after the Service Start Date;
 - ii. Non-Recurring Service Charges shall be invoiced upon the Effective Date; and
 - iii. Hardware shall be invoiced when shipped.
- B. *Payment Terms.* Client shall pay all Monthly Recurring Service Charges monthly in advance, within fifteen (15) days after the date on each invoice, for each Service, from the Service Start Date through the end of Term. Client shall pay all other fees and charges within fifteen (15) days after the date on each invoice. All taxes and governmental fees and charges, if applicable, are not included in the above referenced pricing.

VI. TERMS & CONDITIONS:

- A. This Service Order is incorporated into and made a part of the MSA. Capitalized terms used but not defined in this Service Order have the meanings given to such terms in the MSA. The Ark Terms and Conditions (the "Terms & Conditions") as found at <https://www.arkdna.com/terms/> are incorporated herein by this reference.
- B. Product Codes in the table in Section I above are defined in the applicable Service Description(s), available at sd.arkdna.com (each, a "Service Description"), which are incorporated herein by this reference.
- C. Any number of hours set forth in the table in Section I above under the "QTY" heading are an estimate only, based on the information provided to Ark by Client as of the Effective Date. In the event information changes, or new information becomes available, the estimate of hours may not be sufficient to complete the applicable project. Notwithstanding anything to the contrary herein, Client agrees to pay Ark for the actual hours expended by Ark in performance of the Services.
- D. If there is a conflict between the "Specifications" (as set forth in the table in Section I) and a Service Description, the Service Description shall govern and control.

VII. SUPPLEMENTAL SERVICES:

- A. Ark will provide services outside the scope of this Service Order on a time plus materials and expenses basis (a) when requested and authorized by the Authorized Client Representative during Normal Business Hours (defined below); and/or (b) when requested and authorized by any agent of Client outside Normal Business Hours. "Normal Business Hours" shall mean 8:00AM to 5:00PM local time, Mondays through Fridays, exclusive of holidays. For all work performed outside the scope of this Service Order, Ark shall prepare and submit invoices to Client on the 15th and last business day of each month. Service Charges will be based on the then-current Ark IT Services Rate Card ("Standard Rates") plus travel expenses (if services are provided other than inside the data center) and any applicable sales tax. Standard Rates are from 8:00AM to 5:00PM local time. Service Charges for nights and weekends are 1.5 times Standard Rates, and holidays are two (2) times Standard Rates.

B. Travel expenses are billed at actual cost and mileage at the current IRS rate, portal to portal. Travel expenses include applicable lodging, meals, airfare, and car rental.

VIII. CONFIDENTIALITY:

Client agrees that this Service Order, including without limitation the description of services and the pricing, is the sole and exclusive property of Ark, and shall treat them as Confidential Information pursuant to the terms of the MSA or any confidentiality agreement between the Parties, or if none, under and as defined in the non-disclosure terms & conditions found at <https://www.arkdna.com/nda/>.

IX. ACCEPTANCE:

Each of the undersigned represents that the undersigned has (i) read and understands this Service Order and has full power and authority to sign it, and (ii) agrees and acknowledges that this Service Order is governed by and incorporated into the MSA.

***** Remainder of Page Left Blank Intentionally - Signature Page to Follow *****

Client (legal name): Independent School District No. 709 a/k/a Duluth Public Schools	ark data centers, LLC
Individual signing: Simone Zunich	Individual signing: Stephanie Chiarella
Signature: <small>Signed by:</small>  <small>EB6815704094DE...</small>	Signature: <small>DocuSigned by:</small>  <small>1E49382A82EC419C...</small>
Title: Exec Director of Bs Services	Title: CFO
Signing Date: 5/4/2026	Signing Date: 5/4/2026
Purchase Order #:	
Email (for Notice of Service Start Date):	

Stone Ridge SDA Christian School

Guidelines for

TRANSPORTATION REIMBURSEMENT

2025-2026

1. Each parent is to submit an initial odometer reading from home to school. ISD 709 will determine Maximum Mileage allowed based on District Transportation Routing Software. The initial request should include your school's calendar for the year.
2. ISD 709 Transportation Department will complete the "Invoice/Reimbursement Form" (Form 3000) for each month. Please submit your information monthly, to include mileage and days attended for each family, listing all students in the family. Reimbursement is calculated by:

$$\underline{\hspace{2cm}} \text{ days } \times \underline{\hspace{2cm}} \text{ miles } \times 38 \text{ Cents per mile} = \text{reimbursement.}$$

(One round trip from home to school)

3. Email "DRIVING REIMBURSEMENT REQUEST FORM" to the Transportation Department. A check will be sent to your school in 3-4 weeks from the date received at the Transportation Department.
4. Reimbursement is per family when Duluth Public Schools are in session and only for their mileage. Car pool mileage should not be submitted. For the 2025-2026 school year one family reimbursement is a maximum of \$346.00.
5. All reimbursement claims must be received at ISD 709 by June 5, 2026.

Stone Ridge SDA Christian School

BY _____
Its Director

INDEPENDENT SCHOOL DISTRICT NO. 709

BY *Shirley Zurch* 4.28.26
Director of Business Services

AGREEMENT

THIS AGREEMENT, made and entered into this 27th day of April, 2026, by and between Independent School District #709, a public corporation, hereinafter called District, and Ricky White, an independent contractor, hereinafter called Contractor.

THE PURPOSE OF THE AGREEMENT is to set out the terms and conditions whereby Contractor will provide programs or services for the District at the times and locations set forth in this Agreement.

The terms and conditions of this Agreement are as follows: *(insert here or attach as appropriate)*

1. **Dates of Service.** This Agreement shall be deemed to be effective as of 4-27-2026 and shall remain in effect until 6-30-2026, unless terminated earlier as provided for herein, or unless and until all obligations set forth in this Agreement have been satisfactorily fulfilled, whichever occurs first.

2. **Performance.** *(insert or attach a list of programs/services to be performed by contractor)*

3. **Background Check.** *(applies to contractors working independent with students)*

Contractor must provide an executed criminal history consent form and a money order or check payable to the District in an amount equal to the actual cost of conducting a criminal history background check on all of its employees assigned to the program. Contractor is precluded from performance of contract until the results of the criminal background check(s) are on file.

If Contractor has already completed background checks for their business needs, Contractor stipulates that the background checks are completed, on file, and will be made available for review if the District should request.

Contractor will notify the District of any individual working in our schools with convictions of a gross misdemeanor or felony.

4. **Reimbursement.** In consideration of the performance of Contractor of its obligations pursuant to this Agreement, District hereby agrees to reimburse Contractor for its services and expenses in performing said obligations up to a sum not to exceed \$ 462.00 hourly and \$ 6,000 in total.

Contractor is required by Minnesota Statutes, Section 270.66, subd. 3, to provide their Taxpayer Identification Number (TIN) used in the enforcement of Federal and State tax laws. The TIN will be available to Federal and State tax authorities and State personnel involved in the payment of State obligations. This Agreement will not be approved unless TIN is provided.

5. **Requests for Reimbursement.** The terms of payment under this Agreement are as follows:

- a. Payment shall be made by the District within 30 days of submission of a proper invoice by the Contractor;
- b. Any other terms of payment in the performance of services are incorporated by reference in this Agreement.

6. **Propriety of Expenses.** The fact that the District has reimbursed Contractor for any expense claimed by Contractor shall not preclude District from questioning the propriety of any such item. District reserves the right to offset any overpayment or disallowance of any item or items at any time under this Agreement by reducing future payments to Contractor. This clause shall not be construed to bar any other legal remedies District may have to recover funds expended by Contractor for disallowed costs.

7. **Ownership of Materials.** The District reserves the rights to reproduce the programming in any fashion, or appropriate the contents of the programming, or any portion thereof, to its own use for any and all programs, forms and other materials that Contractor has provided, prepared, or utilized in performance of the terms of this Agreement.

8. **Independent Contractor.** Both the District and Contractor agree that they will act as an independent contractor in the performance of its duties under this Agreement. Nothing contained in this Agreement shall be construed as in any manner creating a relationship of joint venture between the parties, which shall remain independent contractors with respect to all actions performed pursuant to this Agreement.

Accordingly, Contractor shall be responsible for payment of all taxes, including Federal, State, and local taxes, arising out of Contractor's activities in accordance with this Agreement, including by way of illustration, but not limited to, Federal and State income tax, Social Security tax, Unemployment Insurance taxes, workers compensations, and any other taxes or business license fees as required.

9. **Indemnity and defense of the District.** Contractor hereby agrees to defend, indemnify and hold the District harmless from all claims relating to its work pursuant to this Agreement.

In the event that Contractor breaches its obligation to defend, indemnify and hold the District harmless, then in addition to its other damages the District shall be entitled to recover its attorney's fees and costs and disbursements incurred in enforcing this Agreement.

10. **Notices.** All notices to be given by Contractor to District shall be deemed to have been given by depositing the same in writing in the United States Mail: ISD 709, Duluth Public Schools, Attn: American Indian Education 709 Portia Johnson Drive, Duluth, MN 55811.

All notices to be given by District to Contractor shall be deemed to have been given by depositing the same in writing in the United States Mail to (mailing address with zip)



11 **Assignment.** Contractor shall not in any way assign or transfer any of its rights, interests or obligations under this Agreement in any way whatsoever without the prior written approval of the District.

12. **Modification or Amendment.** No amendment, change or modification of this Agreement shall be valid unless in writing signed by the parties' hereto.

13. **Governing Laws.** This Agreement, together with all its paragraphs, terms and provisions is made in the State of Minnesota and shall be construed and interpreted in accordance with the laws of the State of Minnesota.

14. **Entire Agreement.** This Agreement contains the entire understanding of the parties hereto with respect to the subject matter hereof and shall not be changed or otherwise altered except by written agreement of the parties.

15. **Cancellation.** Either party shall have the right to terminate this Agreement, without cause, upon (30) days written notice to the other party as provided for in this Agreement.

16. **Data Practices.** Contractor further understands and agrees that it shall be bound by the Minnesota Government Data Practices Act (Minnesota Statutes 13.03-13.04) with respect to "data on individuals"; as defined in 13.02, subd. 5 of that Statute) which it collects, receives, stores, uses, creates or disseminates pursuant to this Agreement.

17. **Insurance.** (If applicable) Contractor shall not commence work under the contract until they have obtained all the insurance described below and Duluth Public Schools has approved such insurance. Contractor shall maintain such insurance in force and effect throughout the term of the contract.

Contractor is required to maintain and furnish satisfactory evidence of the following insurance policies:

Workers' Compensation Insurance: Contractor must provide Workers' Compensation insurance for all its employees and, in case any work is subcontracted, Contractor will require the subcontractor to provide Workers' Compensation insurance in accordance with the statutory requirements of the State of Minnesota including Coverage B, Employer's Liability.

Commercial General Liability: Contractor is required to maintain insurance protecting it from claims for damages for bodily injury, including sickness or disease, death, and for care and loss of services as well as claims for property damage, including loss of use which may arise from operations under the Contract whether the operations are by the contractor or subcontractor or by anyone directly or indirectly employed under the contract.

18 **Conflict of Interest and Fiduciary Duty:** All contractors doing business with the District agree to follow Policy 307 - Conflicts of Interest and Fiduciary Duty. This policy is located on the District's website.

THE REMAINDER OF THIS PAGE IS LEFT INTENTIONALLY BLANK

AS EVIDENCE OF THEIR ASSENT TO THE TERMS AND CONDITIONS OF THIS AGREEMENT, set forth above, the parties hereto have caused this Agreement to be executed by their duly authorized officers as of the day and year first above written.

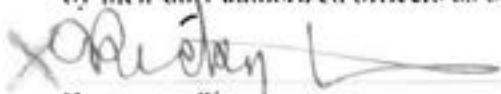
Contractor Signature

SSN/Tax ID Number

4-27-2026
Date

Program Director

4-27-26
Date

Please note: All signatures *must* be obtained AND the following *must* be completed by the Program Director before submission to the Executive Director of Finance & Business Services for review and approval.

This contract is funded by either:

1. The following budget (include full 18 digit code); or
2. will be paid using Student Activity Funds; or
3. is no cost contract (e.g. Memorandum of Understanding).

Please check the appropriate line below:

Check if the contract will be paid using District funds and enter the budget code in the top line below (enter in blank spots following the example).

01	E	005	605	320		340
XX	X	XXX	XXX	XXX	XXX	XXX

Check if the contract will be paid using Student Activity Funds

Check if the contract is a no-cost contract such as a Memorandum of Understanding

Exec. Dir. of Finance & Business Services / Superintendent of Schools / Board Chair

4.27.26
Date

AGREEMENT

THIS AGREEMENT, made and entered into this 13th day of April, 2026, by and between Independent School District #709, a public corporation, hereinafter called District, and Less Gibbons, an independent contractor, hereinafter called Contractor.

THE PURPOSE OF THE AGREEMENT is to set out the terms and conditions whereby Contractor will provide programs or services for the District at the times and locations set forth in this Agreement.

The terms and conditions of this Agreement are as follows: *(insert here or attach as appropriate)*

1. **Dates of Service.** This Agreement shall be deemed to be effective as of **April 13, 2026** and shall remain in effect until **June 30th, 2026**, unless terminated earlier as provided for herein, or unless and until all obligations set forth in this Agreement have been satisfactorily fulfilled, whichever occurs first.

2. **Performance.** *(Must be included)* **Provide MC services for school Powwow, traditional knowledge and cultural specific services.**

3. **Background Check.** *(applies to contractors working independent with students)*

Contractor must provide an executed criminal history consent form and a money order or check payable to the District in an amount equal to the actual cost of conducting a criminal history background check on all of its employees assigned to the program. Contractor is precluded from performance of contract until the results of the criminal background check(s) are on file.

If Contractor has already completed background checks for their business needs, Contractor stipulates that the background checks are completed, on file, and will be made available for review if the District should request.

Contractor will notify the District of any individual working in our schools with convictions of a gross misdemeanor or felony.

4. **Reimbursement.** In consideration of the performance of Contractor of its obligations pursuant to this Agreement, District hereby agrees to reimburse Contractor for its services and expenses in performing said obligations up to a sum not to exceed **\$ 50 / per hour and \$1000_ in total.**

Contractor is required by Minnesota Statutes, Section 270.66, subd. 3, to provide their Taxpayer Identification Number (TIN) used in the enforcement of Federal and State tax laws. The TIN will

be available to Federal and State tax authorities and State personnel involved in the payment of State obligations. This Agreement will not be approved unless TIN is provided.

5. Requests for Reimbursement. The terms of payment under this Agreement are as follows:

- a. Payment shall be made by the District within 30 days of submission of a proper invoice by the Contractor;
- b. Any other terms of payment in the performance of services are incorporated by reference in this Agreement.

6. Propriety of Expenses. The fact that the District has reimbursed Contractor for any expense claimed by Contractor shall not preclude District from questioning the propriety of any such item. District reserves the right to offset any overpayment or disallowance of any item or items at any time under this Agreement by reducing future payments to Contractor. This clause shall not be construed to bar any other legal remedies District may have to recover funds expended by Contractor for disallowed costs.

7. Ownership of Materials. The District reserves the rights to reproduce the programming in any fashion, or appropriate the contents of the programming, or any portion thereof, to its own use for any and all programs, forms and other materials that Contractor has provided, prepared, or utilized in performance of the terms of this Agreement.

8. Independent Contractor. Both the District and Contractor agree that they will act as an independent contractor in the performance of its duties under this Agreement. Nothing contained in this Agreement shall be construed as in any manner creating a relationship of joint venture between the parties, which shall remain independent contractors with respect to all actions performed pursuant to this Agreement.

Accordingly, Contractor shall be responsible for payment of all taxes, including Federal, State, and local taxes, arising out of Contractor's activities in accordance with this Agreement, including by way of illustration, but not limited to, Federal and State income tax, Social Security tax, Unemployment Insurance taxes, workers compensations, and any other taxes or business license fees as required.

9. Indemnity and defense of the District. Contractor hereby agrees to defend, indemnify and hold the District harmless from all claims relating to its work pursuant to this Agreement.

In the event that Contractor breaches its obligation to defend, indemnify and hold the District harmless, then in addition to its other damages the District shall be entitled to recover its attorney's fees and costs and disbursements incurred in enforcing this Agreement.

10. Notices. All notices to be given by Contractor to District shall be deemed to have been given by depositing the same in writing in the United States Mail: ISD 709, Duluth Public Schools, Attn: Duluth American Indian Education , 709 Portia Johnson Drive, Duluth, MN 55811.

All notices to be given by District to Contractor shall be deemed to have been given by depositing the same in writing in the United States Mail to (mailing address with zip) 1011 W 4th St. Duluth MN 55806.

11. Assignment. Contractor shall not in any way assign or transfer any of its rights, interests or obligations under this Agreement in any way whatsoever without the prior written approval of the District.

12. Modification or Amendment. No amendment, change or modification of this Agreement shall be valid unless in writing signed by the parties' hereto.

13. Governing Laws. This Agreement, together with all its paragraphs, terms and provisions is made in the State of Minnesota and shall be construed and interpreted in accordance with the laws of the State of Minnesota.

14. Entire Agreement. This Agreement contains the entire understanding of the parties hereto with respect to the subject matter hereof and shall not be changed or otherwise altered except by written agreement of the parties.

15. Cancellation. Either party shall have the right to terminate this Agreement, without cause, upon (30) days written notice to the other party as provided for in this Agreement.

16. Data Practices. Contractor further understands and agrees that it shall be bound by the Minnesota Government Data Practices Act (Minnesota Statutes 13.03-13.04) with respect to "data on individuals"; as defined in 13.02, subd. 5 of that Statute) which it collects, receives, stores, uses, creates or disseminates pursuant to this Agreement.

17. Insurance. (If applicable) Contractor shall not commence work under the contract until they have obtained all the insurance described below and Duluth Public Schools has approved such insurance. Contractor shall maintain such insurance in force and effect throughout the term of the contract.

Contractor is required to maintain and furnish satisfactory evidence of the following insurance policies:

Workers' Compensation Insurance: Contractor must provide Workers' Compensation insurance for all its employees and, in case any work is subcontracted, Contractor will require the subcontractor to provide Workers' Compensation insurance in accordance with the statutory requirements of the State of Minnesota including Coverage B, Employer's Liability.

Commercial General Liability: Contractor is required to maintain insurance protecting it from claims for damages for bodily injury, including sickness or disease, death, and for care and loss of services as well as claims for property damage, including loss of use which may arise from operations under the Contract whether the operations are by the contractor or subcontractor or by anyone directly or indirectly employed under the contract.

18. Conflict of Interest and Fiduciary Duty: All contractors doing business with the District agree to follow Policy 307 - Conflicts of Interest and Fiduciary Duty. This policy is located on the District's website.

THE REMAINDER OF THIS PAGE IS LEFT INTENTIONALLY BLANK

AGREEMENT

THIS AGREEMENT, made and entered into this 16 th day of April, 2026 , by and between Independent School District #709, a public corporation, hereinafter called District, and Alex Kmett, an independent contractor, hereinafter called Contractor.

THE PURPOSE OF THE AGREEMENT is to set out the terms and conditions whereby Contractor will provide programs or services for the District at the times and locations set forth in this Agreement.

The terms and conditions of this Agreement are as follows: *(insert here or attach as appropriate)*

1. **Dates of Service.** This Agreement shall be deemed to be effective as of April 16 th, 2026 and shall remain in effect until June 30, 2026 , unless terminated earlier as provided for herein, or unless and until all obligations set forth in this Agreement have been satisfactorily fulfilled, whichever occurs first.

2. **Performance.** **(Perform culturally specific services, activities and cultural knowledge as a Spiritual Advisor).**

3. **Background Check.** *(applies to contractors working independent with students.)*

Contractor must provide an executed criminal history consent form and a money order or check payable to the District in an amount equal to the actual cost of conducting a criminal history background check on all of its employees assigned to the program. Contractor is precluded from performance of contract until the results of the criminal background check(s) are on file.

If Contractor has already completed background checks for their business needs, Contractor stipulates that the background checks are completed, on file, and will be made available for review if the District should request.

Contractor will notify the District of any individual working in our schools with convictions of a gross misdemeanor or felony.

4. **Reimbursement.** In consideration of the performance of Contractor of its obligations pursuant to this Agreement, District hereby agrees to reimburse Contractor for its services and expenses in performing said obligations up to a sum not to exceed \$ 50.00 (fifty dollars) hourly / for each performance and \$ 1000.00 (one thousand dollars) in total.

Contractor is required by Minnesota Statutes, Section 270.66, subd. 3, to provide their Taxpayer Identification Number (TIN) used in the enforcement of Federal and State tax laws. The TIN will be available to Federal and State tax authorities and State personnel involved in the payment of State obligations. This Agreement will not be approved unless TIN is provided.

5. **Requests for Reimbursement.** The terms of payment under this Agreement are as follows:

- a. Payment shall be made by the District within 30 days of submission of a proper invoice by the Contractor;
- b. Any other terms of payment in the performance of services are incorporated by reference in this Agreement.

6. **Propriety of Expenses.** The fact that the District has reimbursed Contractor for any expense claimed by Contractor shall not preclude District from questioning the propriety of any such item. District reserves the right to offset any overpayment or disallowance of any item or items at any time under this Agreement by reducing future payments to Contractor. This clause shall not be construed to bar any other legal remedies District may have to recover funds expended by Contractor for disallowed costs.

7. **Ownership of Materials.** The District reserves the rights to reproduce the programming in any fashion, or appropriate the contents of the programming, or any portion thereof, to its own use for any and all programs, forms and other materials that Contractor has provided, prepared, or utilized in performance of the terms of this Agreement.

8. **Independent Contractor.** Both the District and Contractor agree that they will act as an independent contractor in the performance of its duties under this Agreement. Nothing contained in this Agreement shall be construed as in any manner creating a relationship of joint venture between the parties, which shall remain independent contractors with respect to all actions performed pursuant to this Agreement.

Accordingly, Contractor shall be responsible for payment of all taxes, including Federal, State, and local taxes, arising out of Contractor's activities in accordance with this Agreement, including by way of illustration, but not limited to, Federal and State income tax, Social Security tax, Unemployment Insurance taxes, workers compensations, and any other taxes or business license fees as required.

9. **Indemnity and defense of the District.** Contractor hereby agrees to defend, indemnify and hold the District harmless from all claims relating to its work pursuant to this Agreement.

In the event that Contractor breaches its obligation to defend, indemnify and hold the District harmless, then in addition to its other damages the District shall be entitled to recover its attorney's fees and costs and disbursements incurred in enforcing this Agreement.

10. **Notices.** All notices to be given by Contractor to District shall be deemed to have been given by depositing the same in writing in the United States Mail: ISD 709, Duluth Public Schools, Attn: Duluth American Indian Education Department , 709 Portia Johnson Drive, Duluth, MN 55811.

All notices to be given by District to Contractor shall be deemed to have been given by depositing the same in writing in the United States Mail to (mailing address with zip)

Alex Kmett, 1632 Airport Rd., Cloquet MN 55720

11. **Assignment.** Contractor shall not in any way assign or transfer any of its rights, interests or obligations under this Agreement in any way whatsoever without the prior written approval of the District.

12. **Modification or Amendment.** No amendment, change or modification of this Agreement shall be valid unless in writing signed by the parties' hereto.

13. **Governing Laws.** This Agreement, together with all its paragraphs, terms and provisions is made in the State of Minnesota and shall be construed and interpreted in accordance with the laws of the State of Minnesota.

14. **Entire Agreement.** This Agreement contains the entire understanding of the parties hereto with respect to the subject matter hereof and shall not be changed or otherwise altered except by written agreement of the parties.

15. **Cancellation.** Either party shall have the right to terminate this Agreement, without cause, upon (30) days written notice to the other party as provided for in this Agreement.

16. **Data Practices.** Contractor further understands and agrees that it shall be bound by the Minnesota Government Data Practices Act (Minnesota Statutes 13.03-13.04) with respect to "data on individuals"; as defined in 13.02, subd. 5 of that Statute) which it collects, receives, stores, uses, creates or disseminates pursuant to this Agreement.

17. **Insurance.** (If applicable) Contractor shall not commence work under the contract until they have obtained all the insurance described below and Duluth Public Schools has approved such insurance. Contractor shall maintain such insurance in force and effect throughout the term of the contract.

Contractor is required to maintain and furnish satisfactory evidence of the following insurance policies:

Workers' Compensation Insurance: Contractor must provide Workers' Compensation insurance for all its employees and, in case any work is subcontracted, Contractor will require the subcontractor to provide Workers' Compensation insurance in accordance with the statutory requirements of the State of Minnesota including Coverage B, Employer's Liability.

Commercial General Liability: Contractor is required to maintain insurance protecting it from claims for damages for bodily injury, including sickness or disease, death, and for care and loss of services as well as claims for property damage, including loss of use which may arise from operations under the Contract whether the operations are by the contractor or subcontractor or by anyone directly or indirectly employed under the contract.

18. **Conflict of Interest and Fiduciary Duty:** All contractors doing business with the District agree to follow Policy 307 - Conflicts of Interest and Fiduciary Duty. This policy is located on the District's website.

THE REMAINDER OF THIS PAGE IS LEFT INTENTIONALLY BLANK

AS EVIDENCE OF THEIR ASSENT TO THE TERMS AND CONDITIONS OF THIS AGREEMENT, set forth above, the parties hereto have caused this Agreement to be executed by their duly authorized officers as of the day and year first above written.

[REDACTED]
4/16/2026

Contractor Signature
SSN/Tax ID Number
Date

Program Director Date

Please note: All signatures *must* be obtained AND the following *must* be completed by the Program Director before submission to the CFO for review and approval.

This contract is funded by either:

1. The following budget (include full 18 digit code); or
2. will be paid using Student Activity Funds; or
3. is no cost contract (e.g. Memorandum of Understanding).

Please check the appropriate line below:

Check if the contract will be paid using District funds and enter the budget code in the top line below (enter in blank spots following the example).

Check if the contract will be paid using Student Activity Funds

Check if the contract is a no-cost contract such as a Memorandum of Understanding

01	E	225	216	401	303	638
XX	X	XXX	XXX	XXX	XXX	XXX

5/5/26

Exec. Dir Finance & Business Services / Superintendent of Schools / Board Chair
Date

AGREEMENT

THIS AGREEMENT, made and entered into this 16th day of April, 2026, by and between Independent School District #709, a public corporation, hereinafter called District, and **Michael Kesner**, an independent contractor, hereinafter called Contractor.

THE PURPOSE OF THE AGREEMENT is to set out the terms and conditions whereby Contractor will provide programs or services for the District at the times and locations set forth in this Agreement.

The terms and conditions of this Agreement are as follows: *(insert here or attach as appropriate)*

1. **Dates of Service.** This Agreement shall be deemed to be effective as of April 16th, 2026 and shall remain in effect until June 30, 2026, unless terminated earlier as provided for herein, or unless and until all obligations set forth in this Agreement have been satisfactorily fulfilled, whichever occurs first.

2. **Performance.** (**Perform culturally specific services and activities, drumming and singing.**)

3. **Background Check.** *(applies to contractors working independent with students.)*

Contractor must provide an executed criminal history consent form and a money order or check payable to the District in an amount equal to the actual cost of conducting a criminal history background check on all of its employees assigned to the program. Contractor is precluded from performance of contract until the results of the criminal background check(s) are on file.

If Contractor has already completed background checks for their business needs, Contractor stipulates that the background checks are completed, on file, and will be made available for review if the District should request.

Contractor will notify the District of any individual working in our schools with convictions of a gross misdemeanor or felony.

4. **Reimbursement.** In consideration of the performance of Contractor of its obligations pursuant to this Agreement, District hereby agrees to reimburse Contractor for its services and expenses in performing said obligations up to a sum not to exceed \$ 150.00 (One hundred and fifty dollars) hourly / for each performance (1 drum and singers) and \$ 1000.00 (one thousand dollars) in total.

Contractor is required by Minnesota Statutes, Section 270.66, subd. 3, to provide their Taxpayer Identification Number (TIN) used in the enforcement of Federal and State tax laws. The TIN will

be available to Federal and State tax authorities and State personnel involved in the payment of State obligations. This Agreement will not be approved unless TIN is provided.

5. Requests for Reimbursement. The terms of payment under this Agreement are as follows:

- a. Payment shall be made by the District within 30 days of submission of a proper invoice by the Contractor;
- b. Any other terms of payment in the performance of services are incorporated by reference in this Agreement.

6. Propriety of Expenses. The fact that the District has reimbursed Contractor for any expense claimed by Contractor shall not preclude District from questioning the propriety of any such item. District reserves the right to offset any overpayment or disallowance of any item or items at any time under this Agreement by reducing future payments to Contractor. This clause shall not be construed to bar any other legal remedies District may have to recover funds expended by Contractor for disallowed costs.

7. Ownership of Materials. The District reserves the rights to reproduce the programming in any fashion, or appropriate the contents of the programming, or any portion thereof, to its own use for any and all programs, forms and other materials that Contractor has provided, prepared, or utilized in performance of the terms of this Agreement.

8. Independent Contractor. Both the District and Contractor agree that they will act as an independent contractor in the performance of its duties under this Agreement. Nothing contained in this Agreement shall be construed as in any manner creating a relationship of joint venture between the parties, which shall remain independent contractors with respect to all actions performed pursuant to this Agreement.

Accordingly, Contractor shall be responsible for payment of all taxes, including Federal, State, and local taxes, arising out of Contractor's activities in accordance with this Agreement, including by way of illustration, but not limited to, Federal and State income tax, Social Security tax, Unemployment Insurance taxes, workers compensations, and any other taxes or business license fees as required.

9. Indemnity and defense of the District. Contractor hereby agrees to defend, indemnify and hold the District harmless from all claims relating to its work pursuant to this Agreement.

In the event that Contractor breaches its obligation to defend, indemnify and hold the District harmless, then in addition to its other damages the District shall be entitled to recover its attorney's fees and costs and disbursements incurred in enforcing this Agreement.

10. Notices. All notices to be given by Contractor to District shall be deemed to have been given by depositing the same in writing in the United States Mail: ISD 709, Duluth Public Schools, Attn: Duluth American Indian Education Department , 709 Portia Johnson Drive, Duluth, MN 55811.

All notices to be given by District to Contractor shall be deemed to have been given by depositing the same in writing in the United States Mail to (mailing address with zip)

Michael Kesner, 909 Spruce St. Cloquet MN, 55720

11. **Assignment.** Contractor shall not in any way assign or transfer any of its rights, interests or obligations under this Agreement in any way whatsoever without the prior written approval of the District.

12. **Modification or Amendment.** No amendment, change or modification of this Agreement shall be valid unless in writing signed by the parties' hereto.

13. **Governing Laws.** This Agreement, together with all its paragraphs, terms and provisions is made in the State of Minnesota and shall be construed and interpreted in accordance with the laws of the State of Minnesota.

14. **Entire Agreement.** This Agreement contains the entire understanding of the parties hereto with respect to the subject matter hereof and shall not be changed or otherwise altered except by written agreement of the parties.

15. **Cancellation.** Either party shall have the right to terminate this Agreement, without cause, upon (30) days written notice to the other party as provided for in this Agreement.

16. **Data Practices.** Contractor further understands and agrees that it shall be bound by the Minnesota Government Data Practices Act (Minnesota Statutes 13.03-13.04) with respect to "data on individuals"; as defined in 13.02, subd. 5 of that Statute) which it collects, receives, stores, uses, creates or disseminates pursuant to this Agreement.

17. **Insurance.** (If applicable) Contractor shall not commence work under the contract until they have obtained all the insurance described below and Duluth Public Schools has approved such insurance. Contractor shall maintain such insurance in force and effect throughout the term of the contract.

Contractor is required to maintain and furnish satisfactory evidence of the following insurance policies:

Workers' Compensation Insurance: Contractor must provide Workers' Compensation insurance for all its employees and, in case any work is subcontracted, Contractor will require the subcontractor to provide Workers' Compensation insurance in accordance with the statutory requirements of the State of Minnesota including Coverage B, Employer's Liability.

Commercial General Liability: Contractor is required to maintain insurance protecting it from claims for damages for bodily injury, including sickness or disease, death, and for care and loss of services as well as claims for property damage, including loss of use which may arise from operations under the Contract whether the operations are by the contractor or subcontractor or by anyone directly or indirectly employed under the contract.

18. **Conflict of Interest and Fiduciary Duty:** All contractors doing business with the District agree to follow Policy 307 - Conflicts of Interest and Fiduciary Duty. This policy is located on the District's website.

THE REMAINDER OF THIS PAGE IS LEFT INTENTIONALLY BLANK

AS EVIDENCE OF THEIR ASSENT TO THE TERMS AND CONDITIONS OF THIS AGREEMENT, set forth above, the parties hereto have caused this Agreement to be executed by their duly authorized officers as of the day and year first above written.

Michael Kesner [REDACTED] 4/23/26

Contractor Signature SSN/Tax ID Number Date

Program Director Date

Please note: All signatures *must* be obtained AND the following *must* be completed by the Program Director before submission to the CFO for review and approval.

This contract is funded by either:

1. The following budget (include full 18 digit code); or
2. will be paid using Student Activity Funds; or
3. is no cost contract (e.g. Memorandum of Understanding).

Please check the appropriate line below:

Check if the contract will be paid using District funds and enter the budget code in the top line below (enter in blank spots following the example).

Check if the contract will be paid using Student Activity Funds

Check if the contract is a no-cost contract such as a Memorandum of Understanding

01	E	225	216	401	303	638
XX	X	XXX	XXX	XXX	XXX	XXX

Ernie Zwick 5/5/26

Exec. Dir Finance & Business Services / Superintendent of Schools / Board Chair Date

AGREEMENT

THIS AGREEMENT, made and entered into this **14th day of April, 2026**, by and between Independent School District #709, a public corporation, hereinafter called District, and **Thomas Cain**, an independent contractor, hereinafter called Contractor.

THE PURPOSE OF THE AGREEMENT is to set out the terms and conditions whereby Contractor will provide programs or services for the District at the times and locations set forth in this Agreement.

The terms and conditions of this Agreement are as follows: *(insert here or attach as appropriate)*

1. **Dates of Service.** This Agreement shall be deemed to be effective as of **April 14th, 2026** and shall remain in effect until **June 30, 2026**, unless terminated earlier as provided for herein, or unless and until all obligations set forth in this Agreement have been satisfactorily fulfilled, whichever occurs first.

2. **Performance.** *(insert or attach a list of programs/services to be performed by contractor)*

Drumming, Singing, dancing, traditional activities and cultural knowledge.

3. **Background Check.** *(applies to contractors working independent with students)*

Contractor must provide an executed criminal history consent form and a money order or check payable to the District in an amount equal to the actual cost of conducting a criminal history background check on all of its employees assigned to the program. Contractor is precluded from performance of contract until the results of the criminal background check(s) are on file.

If Contractor has already completed background checks for their business needs, Contractor stipulates that the background checks are completed, on file, and will be made available for review if the District should request.

Contractor will notify the District of any individual working in our schools with convictions of a gross misdemeanor or felony.

4. **Reimbursement.** In consideration of the performance of Contractor of its obligations pursuant to this Agreement, District hereby agrees to reimburse Contractor for its services and expenses in performing said obligations up to a sum not to exceed **\$ 150 dollars (one hundred and fifty dollars) hourly (for 1 drum and singers) and \$ 1000.00 in total.**

Contractor is required by Minnesota Statutes, Section 270.66, subd. 3, to provide their Taxpayer Identification Number (TIN) used in the enforcement of Federal and State tax laws. The TIN will be available to Federal and State tax authorities and State personnel involved in the payment of State obligations. This Agreement will not be approved unless TIN is provided.

5. Requests for Reimbursement. The terms of payment under this Agreement are as follows:

- a. Payment shall be made by the District within 30 days of submission of a proper invoice by the Contractor;
- b. Any other terms of payment in the performance of services are incorporated by reference in this Agreement.

6. Propriety of Expenses. The fact that the District has reimbursed Contractor for any expense claimed by Contractor shall not preclude District from questioning the propriety of any such item. District reserves the right to offset any overpayment or disallowance of any item or items at any time under this Agreement by reducing future payments to Contractor. This clause shall not be construed to bar any other legal remedies District may have to recover funds expended by Contractor for disallowed costs.

7. Ownership of Materials. The District reserves the rights to reproduce the programming in any fashion, or appropriate the contents of the programming, or any portion thereof, to its own use for any and all programs, forms and other materials that Contractor has provided, prepared, or utilized in performance of the terms of this Agreement.

8. Independent Contractor. Both the District and Contractor agree that they will act as an independent contractor in the performance of its duties under this Agreement. Nothing contained in this Agreement shall be construed as in any manner creating a relationship of joint venture between the parties, which shall remain independent contractors with respect to all actions performed pursuant to this Agreement.

Accordingly, Contractor shall be responsible for payment of all taxes, including Federal, State, and local taxes, arising out of Contractor's activities in accordance with this Agreement, including by way of illustration, but not limited to, Federal and State income tax, Social Security tax, Unemployment Insurance taxes, workers compensations, and any other taxes or business license fees as required.

9. Indemnity and defense of the District. Contractor hereby agrees to defend, indemnify and hold the District harmless from all claims relating to its work pursuant to this Agreement.

In the event that Contractor breaches its obligation to defend, indemnify and hold the District harmless, then in addition to its other damages the District shall be entitled to recover its attorney's fees and costs and disbursements incurred in enforcing this Agreement.

10. Notices. All notices to be given by Contractor to District shall be deemed to have been given by depositing the same in writing in the United States Mail: ISD 709, Duluth Public Schools, Attn: American Indian Education _____, 709 Portia Johnson Drive, Duluth, MN 55811.

All notices to be given by District to Contractor shall be deemed to have been given by depositing the same in writing in the United States Mail to (mailing address with zip) Thomas Cain 12371 W. County Rd N Couderay, WI 54828.

11. **Assignment.** Contractor shall not in any way assign or transfer any of its rights, interests or obligations under this Agreement in any way whatsoever without the prior written approval of the District.

12. **Modification or Amendment.** No amendment, change or modification of this Agreement shall be valid unless in writing signed by the parties' hereto.

13. **Governing Laws.** This Agreement, together with all its paragraphs, terms and provisions is made in the State of Minnesota and shall be construed and interpreted in accordance with the laws of the State of Minnesota.

14. **Entire Agreement.** This Agreement contains the entire understanding of the parties hereto with respect to the subject matter hereof and shall not be changed or otherwise altered except by written agreement of the parties.

15. **Cancellation.** Either party shall have the right to terminate this Agreement, without cause, upon (30) days written notice to the other party as provided for in this Agreement.

16. **Data Practices.** Contractor further understands and agrees that it shall be bound by the Minnesota Government Data Practices Act (Minnesota Statutes 13.03-13.04) with respect to "data on individuals"; as defined in 13.02, subd. 5 of that Statute) which it collects, receives, stores, uses, creates or disseminates pursuant to this Agreement.

17. **Insurance.** (If applicable) Contractor shall not commence work under the contract until they have obtained all the insurance described below and Duluth Public Schools has approved such insurance. Contractor shall maintain such insurance in force and effect throughout the term of the contract.

Contractor is required to maintain and furnish satisfactory evidence of the following insurance policies:



Workers' Compensation Insurance: Contractor must provide Workers' Compensation insurance for all its employees and, in case any work is subcontracted, Contractor will require the subcontractor to provide Workers' Compensation insurance in accordance with the statutory requirements of the State of Minnesota including Coverage B, Employer's Liability.

Commercial General Liability: Contractor is required to maintain insurance protecting it from claims for damages for bodily injury, including sickness or disease, death, and for care and loss of services as well as claims for property damage, including loss of use which may arise from operations under the Contract whether the operations are by the contractor or subcontractor or by anyone directly or indirectly employed under the contract.

18. Conflict of Interest and Fiduciary Duty: All contractors doing business with the District agree to follow Policy 307 - Conflicts of Interest and Fiduciary Duty. This policy is located on the District's website.

THE REMAINDER OF THIS PAGE IS LEFT INTENTIONALLY BLANK

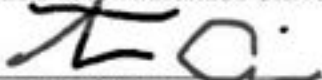
AS EVIDENCE OF THEIR ASSENT TO THE TERMS AND CONDITIONS OF THIS AGREEMENT, set forth above, the parties hereto have caused this Agreement to be executed by their duly authorized officers as of the day and year first above written.



4-14-2026
 Contractor Signature _____ SSN/Tax ID Number _____ Date

 Program Director _____ Date

Please note: All signatures *must* be obtained AND the following *must* be completed by the Program Director before submission to the Executive Director of Finance & Business Services for review and approval.

- This contract is funded by either:**
1. The following budget (include full 18 digit code); or
 2. will be paid using Student Activity Funds; or
 3. is no cost contract (e.g. Memorandum of Understanding).

Please check the appropriate line below:

_____ Check if the contract will be paid using District funds and enter the budget code in the top line below (enter in blank spots following the example).

01	E	225	216	401	303	638
XX	X	XXX	XXX	XXX	XXX	XXX

_____ Check if the contract will be paid using Student Activity Funds

_____ Check if the contract is a no-cost contract such as a Memorandum of Understanding

 Exec. Dir. of Finance & Business Services / Superintendent of Schools / Board Chair _____
5/5/26
Date

AGREEMENT

THIS AGREEMENT, made and entered into this 9th day of April, 2026, by and between Independent School District #709, a public corporation, hereinafter called District, and Kasey Christjohn, an independent contractor, hereinafter called Contractor.

THE PURPOSE OF THE AGREEMENT is to set out the terms and conditions whereby Contractor will provide programs or services for the District at the times and locations set forth in this Agreement.

The terms and conditions of this Agreement are as follows: *(insert here or attach as appropriate)*

1. **Dates of Service.** This Agreement shall be deemed to be effective as of April 9th, 2026 and shall remain in effect until June 30, 2026, unless terminated earlier as provided for herein, or unless and until all obligations set forth in this Agreement have been satisfactorily fulfilled, whichever occurs first.

2. **Performance.** **(Perform culturally specific services and activities, drumming, singing and cultural knowledge.)**

3. **Background Check.** *(applies to contractors working independent with students.)*

Contractor must provide an executed criminal history consent form and a money order or check payable to the District in an amount equal to the actual cost of conducting a criminal history background check on all of its employees assigned to the program. Contractor is precluded from performance of contract until the results of the criminal background check(s) are on file.

If Contractor has already completed background checks for their business needs, Contractor stipulates that the background checks are completed, on file, and will be made available for review if the District should request.

Contractor will notify the District of any individual working in our schools with convictions of a gross misdemeanor or felony.

4. **Reimbursement.** In consideration of the performance of Contractor of its obligations pursuant to this Agreement, District hereby agrees to reimburse Contractor for its services and expenses in performing said obligations up to a sum not to exceed \$ 50.00 (fifty dollars) hourly / for each performance and \$ 1000.00 (one thousand dollars) in total.

Contractor is required by Minnesota Statutes, Section 270.66, subd. 3, to provide their Taxpayer Identification Number (TIN) used in the enforcement of Federal and State tax laws. The TIN will be available to Federal and State tax authorities and State personnel involved in the payment of State obligations. This Agreement will not be approved unless TIN is provided.

5. **Requests for Reimbursement.** The terms of payment under this Agreement are as follows:

- a. Payment shall be made by the District within 30 days of submission of a proper invoice by the Contractor;
- b. Any other terms of payment in the performance of services are incorporated by reference in this Agreement.

6. **Propriety of Expenses.** The fact that the District has reimbursed Contractor for any expense claimed by Contractor shall not preclude District from questioning the propriety of any such item. District reserves the right to offset any overpayment or disallowance of any item or items at any time under this Agreement by reducing future payments to Contractor. This clause shall not be construed to bar any other legal remedies District may have to recover funds expended by Contractor for disallowed costs.

7. **Ownership of Materials.** The District reserves the rights to reproduce the programming in any fashion, or appropriate the contents of the programming, or any portion thereof, to its own use for any and all programs, forms and other materials that Contractor has provided, prepared, or utilized in performance of the terms of this Agreement.

8. **Independent Contractor.** Both the District and Contractor agree that they will act as an independent contractor in the performance of its duties under this Agreement. Nothing contained in this Agreement shall be construed as in any manner creating a relationship of joint venture between the parties, which shall remain independent contractors with respect to all actions performed pursuant to this Agreement.

Accordingly, Contractor shall be responsible for payment of all taxes, including Federal, State, and local taxes, arising out of Contractor's activities in accordance with this Agreement, including by way of illustration, but not limited to, Federal and State income tax, Social Security tax, Unemployment Insurance taxes, workers compensations, and any other taxes or business license fees as required.

9. **Indemnity and defense of the District.** Contractor hereby agrees to defend, indemnify and hold the District harmless from all claims relating to its work pursuant to this Agreement.

In the event that Contractor breaches its obligation to defend, indemnify and hold the District harmless, then in addition to its other damages the District shall be entitled to recover its attorney's fees and costs and disbursements incurred in enforcing this Agreement.

10. **Notices.** All notices to be given by Contractor to District shall be deemed to have been given by depositing the same in writing in the United States Mail: ISD 709, Duluth Public Schools, Attn: Duluth American Indian Education Department , 709 Portia Johnson Drive, Duluth, MN 55811.

All notices to be given by District to Contractor shall be deemed to have been given by depositing the same in writing in the United States Mail to (mailing address with zip) Kasey Christiohn, 1208 South Taylor St. #1, GreenBay WI, 54304.

11. **Assignment.** Contractor shall not in any way assign or transfer any of its rights, interests or obligations under this Agreement in any way whatsoever without the prior written approval of the District.

12. **Modification or Amendment.** No amendment, change or modification of this Agreement shall be valid unless in writing signed by the parties' hereto.

13. **Governing Laws.** This Agreement, together with all its paragraphs, terms and provisions is made in the State of Minnesota and shall be construed and interpreted in accordance with the laws of the State of Minnesota.

14. **Entire Agreement.** This Agreement contains the entire understanding of the parties hereto with respect to the subject matter hereof and shall not be changed or otherwise altered except by written agreement of the parties.

15. **Cancellation.** Either party shall have the right to terminate this Agreement, without cause, upon (30) days written notice to the other party as provided for in this Agreement.

16. **Data Practices.** Contractor further understands and agrees that it shall be bound by the Minnesota Government Data Practices Act (Minnesota Statutes 13.03-13.04) with respect to "data on individuals"; as defined in 13.02, subd. 5 of that Statute) which it collects, receives, stores, uses, creates or disseminates pursuant to this Agreement.

17. **Insurance.** (If applicable) Contractor shall not commence work under the contract until they have obtained all the insurance described below and Duluth Public Schools has approved such insurance. Contractor shall maintain such insurance in force and effect throughout the term of the contract.

Contractor is required to maintain and furnish satisfactory evidence of the following insurance policies:

Workers' Compensation Insurance: Contractor must provide Workers' Compensation insurance for all its employees and, in case any work is subcontracted, Contractor will require the subcontractor to provide Workers' Compensation insurance in accordance with the statutory requirements of the State of Minnesota including Coverage B, Employer's Liability.

Commercial General Liability: Contractor is required to maintain insurance protecting it from claims for damages for bodily injury, including sickness or disease, death, and for care and loss of services as well as claims for property damage, including loss of use which may arise from operations under the Contract whether the operations are by the contractor or subcontractor or by anyone directly or indirectly employed under the contract.

18. **Conflict of Interest and Fiduciary Duty:** All contractors doing business with the District agree to follow Policy 307 - Conflicts of Interest and Fiduciary Duty. This policy is located on the District's website.

THE REMAINDER OF THIS PAGE IS LEFT INTENTIONALLY BLANK

AS EVIDENCE OF THEIR ASSENT TO THE TERMS AND CONDITIONS OF THIS AGREEMENT, set forth above, the parties hereto have caused this Agreement to be executed by their duly authorized officers as of the day and year first above written.

[REDACTED]
4-14-2026

Contractor Signature
SSN/Tax ID Number
Date

Program Director
Date

Please note: All signatures *must* be obtained AND the following *must* be completed by the Program Director before submission to the CFO for review and approval.

This contract is funded by either:

1. The following budget (include full 18 digit code); or
2. will be paid using Student Activity Funds; or
3. is no cost contract (e.g. Memorandum of Understanding).

Please check the appropriate line below:

Check if the contract will be paid using District funds and enter the budget code in the top line below (enter in blank spots following the example).

Check if the contract will be paid using Student Activity Funds

Check if the contract is a no-cost contract such as a Memorandum of Understanding

01	E	225	216	401	303	638
XX	X	XXX	XXX	XXX	XXX	XXX

5/5/26

Exec. Dir Finance & Business Services / Superintendent of Schools / Board Chair
Date

AGREEMENT

THIS AGREEMENT, made and entered into this 16th day of April, 2026, by and between Independent School District #709, a public corporation, hereinafter called District, and **Rizal Agaton Howes**, an independent contractor, hereinafter called Contractor.

THE PURPOSE OF THE AGREEMENT is to set out the terms and conditions whereby Contractor will provide programs or services for the District at the times and locations set forth in this Agreement.

The terms and conditions of this Agreement are as follows: *(insert here or attach as appropriate)*

1. **Dates of Service.** This Agreement shall be deemed to be effective as of April 16th, 2026 and shall remain in effect until June 30, 2026, unless terminated earlier as provided for herein, or unless and until all obligations set forth in this Agreement have been satisfactorily fulfilled, whichever occurs first.

2. **Performance.** **(Perform culturally specific services and activities, drumming and singing.)**

3. **Background Check.** *(applies to contractors working independent with students.)*

Contractor must provide an executed criminal history consent form and a money order or check payable to the District in an amount equal to the actual cost of conducting a criminal history background check on all of its employees assigned to the program. Contractor is precluded from performance of contract until the results of the criminal background check(s) are on file.

If Contractor has already completed background checks for their business needs, Contractor stipulates that the background checks are completed, on file, and will be made available for review if the District should request.

Contractor will notify the District of any individual working in our schools with convictions of a gross misdemeanor or felony.

4. **Reimbursement.** In consideration of the performance of Contractor of its obligations pursuant to this Agreement, District hereby agrees to reimburse Contractor for its services and expenses in performing said obligations up to a sum not to exceed \$ 150.00 (One hundred and fifty dollars) hourly / for each performance (1 drum and singers) and \$ 1000.00 (one thousand dollars) in total.

Contractor is required by Minnesota Statutes, Section 270.66, subd. 3, to provide their Taxpayer Identification Number (TIN) used in the enforcement of Federal and State tax laws. The TIN will

be available to Federal and State tax authorities and State personnel involved in the payment of State obligations. This Agreement will not be approved unless TIN is provided.

5. **Requests for Reimbursement.** The terms of payment under this Agreement are as follows:

- a. Payment shall be made by the District within 30 days of submission of a proper invoice by the Contractor;
- b. Any other terms of payment in the performance of services are incorporated by reference in this Agreement.

6. **Propriety of Expenses.** The fact that the District has reimbursed Contractor for any expense claimed by Contractor shall not preclude District from questioning the propriety of any such item. District reserves the right to offset any overpayment or disallowance of any item or items at any time under this Agreement by reducing future payments to Contractor. This clause shall not be construed to bar any other legal remedies District may have to recover funds expended by Contractor for disallowed costs.

7. **Ownership of Materials.** The District reserves the rights to reproduce the programming in any fashion, or appropriate the contents of the programming, or any portion thereof, to its own use for any and all programs, forms and other materials that Contractor has provided, prepared, or utilized in performance of the terms of this Agreement.

8. **Independent Contractor.** Both the District and Contractor agree that they will act as an independent contractor in the performance of its duties under this Agreement. Nothing contained in this Agreement shall be construed as in any manner creating a relationship of joint venture between the parties, which shall remain independent contractors with respect to all actions performed pursuant to this Agreement.

Accordingly, Contractor shall be responsible for payment of all taxes, including Federal, State, and local taxes, arising out of Contractor's activities in accordance with this Agreement, including by way of illustration, but not limited to, Federal and State income tax, Social Security tax, Unemployment Insurance taxes, workers compensations, and any other taxes or business license fees as required.

9. **Indemnity and defense of the District.** Contractor hereby agrees to defend, indemnify and hold the District harmless from all claims relating to its work pursuant to this Agreement.

In the event that Contractor breaches its obligation to defend, indemnify and hold the District harmless, then in addition to its other damages the District shall be entitled to recover its attorney's fees and costs and disbursements incurred in enforcing this Agreement.

10. **Notices.** All notices to be given by Contractor to District shall be deemed to have been given by depositing the same in writing in the United States Mail: ISD 709, Duluth Public Schools, Attn: Duluth American Indian Education Department , 709 Portia Johnson Drive, Duluth, MN 55811.

All notices to be given by District to Contractor shall be deemed to have been given by depositing the same in writing in the United States Mail to (mailing address with zip)
Rizal Agaton Howes, 3197 Maple Dr. Cloquet, MN 55720.

11. **Assignment.** Contractor shall not in any way assign or transfer any of its rights, interests or obligations under this Agreement in any way whatsoever without the prior written approval of the District.

12. **Modification or Amendment.** No amendment, change or modification of this Agreement shall be valid unless in writing signed by the parties' hereto.

13. **Governing Laws.** This Agreement, together with all its paragraphs, terms and provisions is made in the State of Minnesota and shall be construed and interpreted in accordance with the laws of the State of Minnesota.

14. **Entire Agreement.** This Agreement contains the entire understanding of the parties hereto with respect to the subject matter hereof and shall not be changed or otherwise altered except by written agreement of the parties.

15. **Cancellation.** Either party shall have the right to terminate this Agreement, without cause, upon (30) days written notice to the other party as provided for in this Agreement.

16. **Data Practices.** Contractor further understands and agrees that it shall be bound by the Minnesota Government Data Practices Act (Minnesota Statutes 13.03-13.04) with respect to "data on individuals"; as defined in 13.02, subd. 5 of that Statute) which it collects, receives, stores, uses, creates or disseminates pursuant to this Agreement.

17. **Insurance.** (If applicable) Contractor shall not commence work under the contract until they have obtained all the insurance described below and Duluth Public Schools has approved such insurance. Contractor shall maintain such insurance in force and effect throughout the term of the contract.

Contractor is required to maintain and furnish satisfactory evidence of the following insurance policies:

Workers' Compensation Insurance: Contractor must provide Workers' Compensation insurance for all its employees and, in case any work is subcontracted, Contractor will require the subcontractor to provide Workers' Compensation insurance in accordance with the statutory requirements of the State of Minnesota including Coverage B, Employer's Liability.

Commercial General Liability: Contractor is required to maintain insurance protecting it from claims for damages for bodily injury, including sickness or disease, death, and for care and loss of services as well as claims for property damage, including loss of use which may arise from operations under the Contract whether the operations are by the contractor or subcontractor or by anyone directly or indirectly employed under the contract.

18. **Conflict of Interest and Fiduciary Duty:** All contractors doing business with the District agree to follow Policy 307 - Conflicts of Interest and Fiduciary Duty. This policy is located on the District's website.

THE REMAINDER OF THIS PAGE IS LEFT INTENTIONALLY BLANK

AS EVIDENCE OF THEIR ASSENT TO THE TERMS AND CONDITIONS OF THIS AGREEMENT, set forth above, the parties hereto have caused this Agreement to be executed by their duly authorized officers as of the day and year first above written.

Riyal Ash [REDACTED] 04/22/2026

Contractor Signature **SSN/Tax ID Number** **Date**

Program Director **Date**

Please note: All signatures *must* be obtained AND the following *must* be completed by the Program Director before submission to the CFO for review and approval.

This contract is funded by either:

1. The following budget (include full 18 digit code); or
2. will be paid using Student Activity Funds; or
3. is no cost contract (e.g. Memorandum of Understanding).

Please check the appropriate line below:

Check if the contract will be paid using District funds and enter the budget code in the top line below (enter in blank spots following the example).

Check if the contract will be paid using Student Activity Funds

Check if the contract is a no-cost contract such as a Memorandum of Understanding

01	E	225 5	216	401	303	638
XX	X	XXX	XXX	XXX	XXX	XXX

Simone Zunic 5/5/26

Exec. Dir Finance & Business Services / Superintendent of Schools / Board Chair **Date**

AGREEMENT

THIS AGREEMENT, made and entered into this 14th day of April, 2026 , by and between Independent School District #709, a public corporation, hereinafter called District, and **Mark Steeno** , an independent contractor, hereinafter called Contractor.

THE PURPOSE OF THE AGREEMENT is to set out the terms and conditions whereby Contractor will provide programs or services for the District at the times and locations set forth in this Agreement.

The terms and conditions of this Agreement are as follows: *(insert here or attach as appropriate)*

1. **Dates of Service.** This Agreement shall be deemed to be effective as of April 14th, 2026 and shall remain in effect until June 30, 2026 , unless terminated earlier as provided for herein, or unless and until all obligations set forth in this Agreement have been satisfactorily fulfilled, whichever occurs first.

2. **Performance.** (**Perform culturally specific services and activities, drumming, singing and provide cultural knowledge.**)

3. **Background Check.** *(applies to contractors working independent with students.)*

Contractor must provide an executed criminal history consent form and a money order or check payable to the District in an amount equal to the actual cost of conducting a criminal history background check on all of its employees assigned to the program. Contractor is precluded from performance of contract until the results of the criminal background check(s) are on file.

If Contractor has already completed background checks for their business needs, Contractor stipulates that the background checks are completed, on file, and will be made available for review if the District should request.

Contractor will notify the District of any individual working in our schools with convictions of a gross misdemeanor or felony.

4. **Reimbursement.** In consideration of the performance of Contractor of its obligations pursuant to this Agreement, District hereby agrees to reimburse Contractor for its services and expenses in performing said obligations up to a sum not to exceed \$ 150.00 (One hundred and fifty dollars) hourly / for each performance (1 drum and singers) and \$ 1000.00 (one thousand dollars) in total.

Contractor is required by Minnesota Statutes, Section 270.66, subd. 3, to provide their Taxpayer Identification Number (TIN) used in the enforcement of Federal and State tax laws. The TIN will

be available to Federal and State tax authorities and State personnel involved in the payment of State obligations. This Agreement will not be approved unless TIN is provided.

5. Requests for Reimbursement. The terms of payment under this Agreement are as follows:

- a. Payment shall be made by the District within 30 days of submission of a proper invoice by the Contractor;
- b. Any other terms of payment in the performance of services are incorporated by reference in this Agreement.

6. Propriety of Expenses. The fact that the District has reimbursed Contractor for any expense claimed by Contractor shall not preclude District from questioning the propriety of any such item. District reserves the right to offset any overpayment or disallowance of any item or items at any time under this Agreement by reducing future payments to Contractor. This clause shall not be construed to bar any other legal remedies District may have to recover funds expended by Contractor for disallowed costs.

7. Ownership of Materials. The District reserves the rights to reproduce the programming in any fashion, or appropriate the contents of the programming, or any portion thereof, to its own use for any and all programs, forms and other materials that Contractor has provided, prepared, or utilized in performance of the terms of this Agreement.

8. Independent Contractor. Both the District and Contractor agree that they will act as an independent contractor in the performance of its duties under this Agreement. Nothing contained in this Agreement shall be construed as in any manner creating a relationship of joint venture between the parties, which shall remain independent contractors with respect to all actions performed pursuant to this Agreement.

Accordingly, Contractor shall be responsible for payment of all taxes, including Federal, State, and local taxes, arising out of Contractor's activities in accordance with this Agreement, including by way of illustration, but not limited to, Federal and State income tax, Social Security tax, Unemployment Insurance taxes, workers compensations, and any other taxes or business license fees as required.

9. Indemnity and defense of the District. Contractor hereby agrees to defend, indemnify and hold the District harmless from all claims relating to its work pursuant to this Agreement.

In the event that Contractor breaches its obligation to defend, indemnify and hold the District harmless, then in addition to its other damages the District shall be entitled to recover its attorney's fees and costs and disbursements incurred in enforcing this Agreement.

10. Notices. All notices to be given by Contractor to District shall be deemed to have been given by depositing the same in writing in the United States Mail: ISD 709, Duluth Public Schools, Attn: Duluth American Indian Education Department , 709 Portia Johnson Drive, Duluth, MN 55811.

All notices to be given by District to Contractor shall be deemed to have been given by depositing the same in writing in the United States Mail to (mailing address with zip)

Mark Steeno, N6490 Evergreen Dr., Oneida Wisconsin 54155

11. **Assignment.** Contractor shall not in any way assign or transfer any of its rights, interests or obligations under this Agreement in any way whatsoever without the prior written approval of the District.

12. **Modification or Amendment.** No amendment, change or modification of this Agreement shall be valid unless in writing signed by the parties' hereto.

13. **Governing Laws.** This Agreement, together with all its paragraphs, terms and provisions is made in the State of Minnesota and shall be construed and interpreted in accordance with the laws of the State of Minnesota.

14. **Entire Agreement.** This Agreement contains the entire understanding of the parties hereto with respect to the subject matter hereof and shall not be changed or otherwise altered except by written agreement of the parties.

15. **Cancellation.** Either party shall have the right to terminate this Agreement, without cause, upon (30) days written notice to the other party as provided for in this Agreement.

16. **Data Practices.** Contractor further understands and agrees that it shall be bound by the Minnesota Government Data Practices Act (Minnesota Statutes 13.03-13.04) with respect to "data on individuals"; as defined in 13.02, subd. 5 of that Statute) which it collects, receives, stores, uses, creates or disseminates pursuant to this Agreement.

17. **Insurance.** (If applicable) Contractor shall not commence work under the contract until they have obtained all the insurance described below and Duluth Public Schools has approved such insurance. Contractor shall maintain such insurance in force and effect throughout the term of the contract.

Contractor is required to maintain and furnish satisfactory evidence of the following insurance policies:

Workers' Compensation Insurance: Contractor must provide Workers' Compensation Insurance for all its employees and, in case any work is subcontracted, Contractor will require the subcontractor to provide Workers' Compensation insurance in accordance with the statutory requirements of the State of Minnesota including Coverage B, Employer's Liability.

Commercial General Liability: Contractor is required to maintain insurance protecting it from claims for damages for bodily injury, including sickness or disease, death, and for care and loss of services as well as claims for property damage, including loss of use which may arise from operations under the Contract whether the operations are by the contractor or subcontractor or by anyone directly or indirectly employed under the contract.

18. **Conflict of Interest and Fiduciary Duty:** All contractors doing business with the District agree to follow Policy 307 - Conflicts of Interest and Fiduciary Duty. This policy is located on the District's website.

THE REMAINDER OF THIS PAGE IS LEFT INTENTIONALLY BLANK

AS EVIDENCE OF THEIR ASSENT TO THE TERMS AND CONDITIONS OF THIS AGREEMENT, set forth above, the parties hereto have caused this Agreement to be executed by their duly authorized officers as of the day and year first above written.

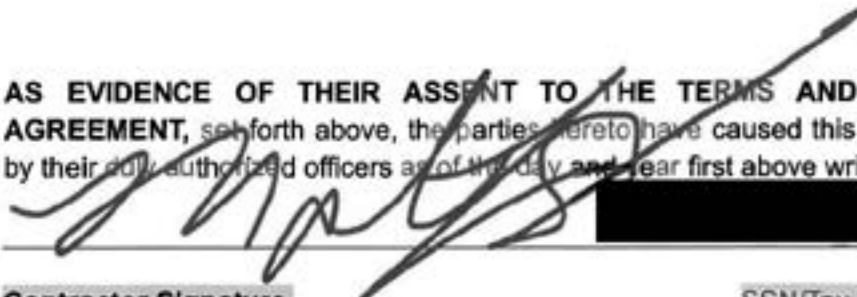
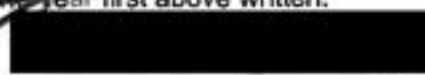
  4/23/26
 Contractor Signature SSN/Tax ID Number Date

 Program Director Date

Please note: All signatures *must* be obtained AND the following *must* be completed by the Program Director before submission to the CFO for review and approval.

This contract is funded by either:

1. The following budget (include full 18 digit code); or
2. will be paid using Student Activity Funds; or
3. is no cost contract (e.g. Memorandum of Understanding).

Please check the appropriate line below:

- Check if the contract will be paid using District funds and enter the budget code in the top line below (enter in blank spots following the example).
- Check if the contract will be paid using Student Activity Funds
- Check if the contract is a no-cost contract such as a Memorandum of Understanding

01	E	225	216	401	303	638
xx	x	xxx	xxx	xxx	xxx	xxx

 5/5/26
 Exec. Dir Finance & Business Services / Superintendent of Schools / Board Chair Date

AGREEMENT

THIS AGREEMENT, made and entered into this 23rd day of April, 2026, by and between Independent School District #709, a public corporation, hereinafter called District, and Phyllis Pohl, an independent contractor, hereinafter called Contractor.

THE PURPOSE OF THE AGREEMENT is to set out the terms and conditions whereby Contractor will provide programs or services for the District at the times and locations set forth in this Agreement.

The terms and conditions of this Agreement are as follows: *(insert here or attach as appropriate)*

1. **Dates of Service.** This Agreement shall be deemed to be effective as of 4-23-26 and shall remain in effect until 6-30-26, unless terminated earlier as provided for herein, or unless and until all obligations set forth in this Agreement have been satisfactorily fulfilled, whichever occurs first.

2. **Performance.** *(insert or attach a list of programs/services to be performed by contractor)*

3. **Background Check.** *(applies to contractors working independent with students)*

Contractor must provide an executed criminal history consent form and a money order or check payable to the District in an amount equal to the actual cost of conducting a criminal history background check on all of its employees assigned to the program. Contractor is precluded from performance of contract until the results of the criminal background check(s) are on file.

If Contractor has already completed background checks for their business needs, Contractor stipulates that the background checks are completed, on file, and will be made available for review if the District should request.

Contractor will notify the District of any individual working in our schools with convictions of a gross misdemeanor or felony.

4. **Reimbursement.** In consideration of the performance of Contractor of its obligations pursuant to this Agreement, District hereby agrees to reimburse Contractor for its services and expenses in performing said obligations up to a sum not to exceed \$— hourly and \$5,000 in total.

Contractor is required by Minnesota Statutes, Section 270.66, subd. 3, to provide their Taxpayer Identification Number (TIN) used in the enforcement of Federal and State tax laws. The TIN will be available to Federal and State tax authorities and State personnel involved in the payment of State obligations. This Agreement will not be approved unless TIN is provided.

5. **Requests for Reimbursement.** The terms of payment under this Agreement are as follows:

- a. Payment shall be made by the District within 30 days of submission of a proper invoice by the Contractor;
- b. Any other terms of payment in the performance of services are incorporated by reference in this Agreement.

6. **Propriety of Expenses.** The fact that the District has reimbursed Contractor for any expense claimed by Contractor shall not preclude District from questioning the propriety of any such item. District reserves the right to offset any overpayment or disallowance of any item or items at any time under this Agreement by reducing future payments to Contractor. This clause shall not be construed to bar any other legal remedies District may have to recover funds expended by Contractor for disallowed costs.

7. **Ownership of Materials.** The District reserves the rights to reproduce the programming in any fashion, or appropriate the contents of the programming, or any portion thereof, to its own use for any and all programs, forms and other materials that Contractor has provided, prepared, or utilized in performance of the terms of this Agreement.

8. **Independent Contractor.** Both the District and Contractor agree that they will act as an independent contractor in the performance of its duties under this Agreement. Nothing contained in this Agreement shall be construed as in any manner creating a relationship of joint venture between the parties, which shall remain independent contractors with respect to all actions performed pursuant to this Agreement.

Accordingly, Contractor shall be responsible for payment of all taxes, including Federal, State, and local taxes, arising out of Contractor's activities in accordance with this Agreement, including by way of illustration, but not limited to, Federal and State income tax, Social Security tax, Unemployment Insurance taxes, workers compensations, and any other taxes or business license fees as required.

9. **Indemnity and defense of the District.** Contractor hereby agrees to defend, indemnify and hold the District harmless from all claims relating to its work pursuant to this Agreement.

In the event that Contractor breaches its obligation to defend, indemnify and hold the District harmless, then in addition to its other damages the District shall be entitled to recover its attorney's fees and costs and disbursements incurred in enforcing this Agreement.

10. **Notices.** All notices to be given by Contractor to District shall be deemed to have been given by depositing the same in writing in the United States Mail: ISD 709, Duluth Public Schools, Attn: American Indian Education, 709 Portia Johnson Drive, Duluth, MN 55811.

All notices to be given by District to Contractor shall be deemed to have been given by depositing the same in writing in the United States Mail to (mailing address with zip)
3730 W 7th St, Duluth MN 55807

11. **Assignment.** Contractor shall not in any way assign or transfer any of its rights, interests or obligations under this Agreement in any way whatsoever without the prior written approval of the District.

12. **Modification or Amendment.** No amendment, change or modification of this Agreement shall be valid unless in writing signed by the parties' hereto.

13. **Governing Laws.** This Agreement, together with all its paragraphs, terms and provisions is made in the State of Minnesota and shall be construed and interpreted in accordance with the laws of the State of Minnesota.

14. **Entire Agreement.** This Agreement contains the entire understanding of the parties hereto with respect to the subject matter hereof and shall not be changed or otherwise altered except by written agreement of the parties.

15. **Cancellation.** Either party shall have the right to terminate this Agreement, without cause, upon (30) days written notice to the other party as provided for in this Agreement.

16. **Data Practices.** Contractor further understands and agrees that it shall be bound by the Minnesota Government Data Practices Act (Minnesota Statutes 13.03-13.04) with respect to "data on individuals"; as defined in 13.02, subd. 5 of that Statute) which it collects, receives, stores, uses, creates or disseminates pursuant to this Agreement.

17. **Insurance.** (If applicable) Contractor shall not commence work under the contract until they have obtained all the insurance described below and Duluth Public Schools has approved such insurance. Contractor shall maintain such insurance in force and effect throughout the term of the contract.

Contractor is required to maintain and furnish satisfactory evidence of the following insurance policies:

Workers' Compensation Insurance: Contractor must provide Workers' Compensation insurance for all its employees and, in case any work is subcontracted, Contractor will require the subcontractor to provide Workers' Compensation insurance in accordance with the statutory requirements of the State of Minnesota including Coverage B, Employer's Liability.

Commercial General Liability: Contractor is required to maintain insurance protecting it from claims for damages for bodily injury, including sickness or disease, death, and for care and loss of services as well as claims for property damage, including loss of use which may arise from operations under the Contract whether the operations are by the contractor or subcontractor or by anyone directly or indirectly employed under the contract.

18. **Conflict of Interest and Fiduciary Duty:** All contractors doing business with the District agree to follow Policy 307 - Conflicts of Interest and Fiduciary Duty. This policy is located on the District's website.

THE REMAINDER OF THIS PAGE IS LEFT INTENTIONALLY BLANK

AS EVIDENCE OF THEIR ASSENT TO THE TERMS AND CONDITIONS OF THIS AGREEMENT, set forth above, the parties hereto have caused this Agreement to be executed by their duly authorized officers as of the day and year first above written.

[REDACTED]
4/23/24
 Contractor Signature SSN/Tax ID Number Date

 Program Director Date

Please note: All signatures *must* be obtained AND the following *must* be completed by the Program Director before submission to the Executive Director of Finance & Business Services for review and approval.

This contract is funded by either:

1. The following budget (include full 18 digit code); or
2. will be paid using Student Activity Funds; or
3. is no cost contract (e.g. Memorandum of Understanding).

Please check the appropriate line below:

Check if the contract will be paid using District funds and enter the budget code in the top line below (enter in blank spots following the example).

01	E	005	605	320	305	340
XX	X	XXX	XXX	XXX	XXX	XXX

_____ Check if the contract will be paid using Student Activity Funds

_____ Check if the contract is a no-cost contract such as a Memorandum of Understanding

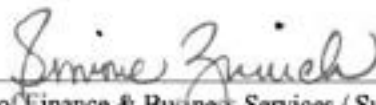
5/6/26
 Exec. Dir. of Finance & Business Services / Superintendent of Schools / Board Chair Date

Contracted Services

Explanation & Details of Services Rendered

We are contracting services with Phyllis Pohl for the creation of traditional shawls to be used by American Indian students during the Lincoln Park Pow wow on **May 9th**.

The contractor will utilize fabric and ribbon materials provided by our program to design and construct these shawls, which serve as important pieces of cultural regalia for dance and celebration.

This work supports student participation in culturally significant practices and helps ensure that students are able to engage fully and respectfully in the powwow.

The contractor is responsible for providing the labor, skill, and craftsmanship necessary to complete the shawls in a timely manner for the event.



Office of American Indian Education

Duluth Public Schools ISD709

Address: 709 Portia Johnson Dr, Duluth, Minnesota 55811

Phone: 218-336-8700 Ext.1034 or Email: melanie.black@isd709.org

04-23-2026

AGREEMENT

THIS AGREEMENT, made and entered into this **23rd of April 2026**, by and between Independent School District #709, a public corporation, hereinafter called District, and **Jakob Wilson**, an independent contractor, hereinafter called Contractor.

THE PURPOSE OF THE AGREEMENT is to set out the terms and conditions whereby Contractor will provide programs or services for the District at the times and locations set forth in this Agreement.

The terms and conditions of this Agreement are as follows: *(insert here or attach as appropriate)*

1. **Dates of Service.** This Agreement shall be deemed to be effective as of **April 23, 2026 and shall remain in effect until June 30, 2026**, unless terminated earlier as provided for herein, or unless and until all obligations set forth in this Agreement have been satisfactorily fulfilled, whichever occurs first.

2. **Performance.** *(insert or attach a list of programs/services to be performed by contractor)*

Provide cultural specific drumming and singing services.

3. **Background Check.** Contractor will not be working independently with students

Contractor must provide an executed criminal history consent form and a money order or check payable to the District in an amount equal to the actual cost of conducting a criminal history background check on all of its employees assigned to the program. Contractor is precluded from performance of contract until the results of the criminal background check(s) are on file.

If Contractor has already completed background checks for their business needs, Contractor stipulates that the background checks are completed, on file, and will be made available for review if the District should request.

Contractor will notify the District of any individual working in our schools with convictions of a gross misdemeanor or felony.

4. **Reimbursement.** In consideration of the performance of Contractor of its obligations pursuant to this Agreement, District hereby agrees to reimburse Contractor for its services and expenses in performing said obligations up to a sum not to exceed **\$ 150.00 (One hundred and fifty dollars) hourly for each performance (1 drum and singers) and \$ 1000.00 (one thousand dollars) in total.**

Contractor is required by Minnesota Statutes, Section 270.66, subd. 3, to provide their Taxpayer Identification Number (TIN) used in the enforcement of Federal and State tax laws. The TIN

will be available to Federal and State tax authorities and State personnel involved in the payment of State obligations. This Agreement will not be approved unless TIN is provided.

5. Requests for Reimbursement. The terms of payment under this Agreement are as follows:

- a. Payment shall be made by the District within 30 days of submission of a proper invoice by the Contractor;
- b. Any other terms of payment in the performance of services are incorporated by reference in this Agreement.

6. Propriety of Expenses. The fact that the District has reimbursed Contractor for any expense claimed by Contractor shall not preclude District from questioning the propriety of any such item. District reserves the right to offset any overpayment or disallowance of any item or items at any time under this Agreement by reducing future payments to Contractor. This clause shall not be construed to bar any other legal remedies District may have to recover funds expended by Contractor for disallowed costs.

7. Ownership of Materials. The District reserves the rights to reproduce the programming in any fashion, or appropriate the contents of the programming, or any portion thereof, to its own use for any and all programs, forms and other materials that Contractor has provided, prepared, or utilized in performance of the terms of this Agreement.

8. Independent Contractor. Both the District and Contractor agree that they will act as an independent contractor in the performance of its duties under this Agreement. Nothing contained in this Agreement shall be construed as in any manner creating a relationship of joint venture between the parties, which shall remain independent contractors with respect to all actions performed pursuant to this Agreement.

Accordingly, Contractor shall be responsible for payment of all taxes, including Federal, State, and local taxes, arising out of Contractor's activities in accordance with this Agreement, including by way of illustration, but not limited to, Federal and State income tax, Social Security tax, Unemployment Insurance taxes, workers compensations, and any other taxes or business license fees as required.

9. Indemnity and defense of the District. Contractor hereby agrees to defend, indemnify and hold the District harmless from all claims relating to its work pursuant to this Agreement.

In the event that Contractor breaches its obligation to defend, indemnify and hold the District harmless, then in addition to its other damages the District shall be entitled to recover its attorney's fees and costs and disbursements incurred in enforcing this Agreement.

10. Notices. All notices to be given by Contractor to District shall be deemed to have been given by depositing the same in writing in the United States Mail: ISD 709, Duluth Public Schools, Attn: Duluth American Indian Education ,709 Portia Johnson Drive , Duluth, MN 55811.

All notices to be given by District to Contractor shall be deemed to have been given by depositing the same in writing in the United States Mail to (mailing address with zip)
Jakob Wilson, 260 Gagwagin Road, Cloquet MN 55720.

11. **Assignment.** Contractor shall not in any way assign or transfer any of its rights, interests or obligations under this Agreement in any way whatsoever without the prior written approval of the District.

12. **Modification or Amendment.** No amendment, change or modification of this Agreement shall be valid unless in writing signed by the parties' hereto.

13. **Governing Laws.** This Agreement, together with all its paragraphs, terms and provisions is made in the State of Minnesota and shall be construed and interpreted in accordance with the laws of the State of Minnesota.

14. **Entire Agreement.** This Agreement contains the entire understanding of the parties hereto with respect to the subject matter hereof and shall not be changed or otherwise altered except by written agreement of the parties.

15. **Cancellation.** Either party shall have the right to terminate this Agreement, without cause, upon (30) days written notice to the other party as provided for in this Agreement.

16. **Data Practices.** Contractor further understands and agrees that it shall be bound by the Minnesota Government Data Practices Act (Minnesota Statutes 13.03-13.04) with respect to "data on individuals"; as defined in 13.02, subd. 5 of that Statute) which it collects, receives, stores, uses, creates or disseminates pursuant to this Agreement.

17. **Insurance.** (If applicable) Contractor shall not commence work under the contract until they have obtained all the insurance described below and Duluth Public Schools has approved such insurance. Contractor shall maintain such insurance in force and effect throughout the term of the contract.

Contractor is required to maintain and furnish satisfactory evidence of the following insurance policies:

Workers' Compensation Insurance: Contractor must provide Workers' Compensation insurance for all its employees and, in case any work is subcontracted, Contractor will require the subcontractor to provide Workers' Compensation insurance in accordance with the statutory requirements of the State of Minnesota including Coverage B, Employer's Liability.

Commercial General Liability: Contractor is required to maintain insurance protecting it from claims for damages for bodily injury, including sickness or disease, death, and for care and loss of services as well as claims for property damage, including loss of use which may arise from

operations under the Contract whether the operations are by the contractor or subcontractor or by anyone directly or indirectly employed under the contract.

18. Conflict of Interest and Fiduciary Duty: All contractors doing business with the District agree to follow Policy 307 - Conflicts of Interest and Fiduciary Duty. This policy is located on the District's website.

THE REMAINDER OF THIS PAGE IS LEFT INTENTIONALLY BLANK

AS EVIDENCE OF THEIR ASSENT TO THE TERMS AND CONDITIONS OF THIS AGREEMENT, set forth above, the parties hereto have caused this Agreement to be executed by their duly authorized officers as of the day and year first above written.

 _____ SSN/Tax ID Number  Date 4/23/2026

 _____ Date 5/5/26

Please note: All signatures *must* be obtained AND the following *must* be completed by the Program Director before submission to the CFO for review and approval.

This contract is funded by either:

1. The following budget (include full 18 digit code); or
2. will be paid using Student Activity Funds; or
3. is no cost contract (e.g. Memorandum of Understanding).

Please check the appropriate line below:

Check if the contract will be paid using District funds and enter the budget code in the top line below (enter in blank spots following the example).

01	E	225	216	401	305	638
XX	X	XXX	XXX	XXX	XXX	XXX

____ Check if the contract will be paid using Student Activity Funds

____ Check if the contract is a no-cost contract such as a Memorandum of Understanding

 _____ Date 5/6/26

Exec. Dir. of Finance & Business Services / Superintendent of Schools / Board Chair

AGREEMENT

THIS AGREEMENT, made and entered into this 30th day of April, 2026, by and between Independent School District #709, a public corporation, hereinafter called District, and Debra Win Deleary, an independent contractor, hereinafter called Contractor.

THE PURPOSE OF THE AGREEMENT is to set out the terms and conditions whereby Contractor will provide programs or services for the District at the times and locations set forth in this Agreement.

The terms and conditions of this Agreement are as follows: *(insert here or attach as appropriate)*

1. **Dates of Service.** This Agreement shall be deemed to be effective as of April 30, 2026__ and shall remain in effect until June 30, 2026__, unless terminated earlier as provided for herein, or unless and until all obligations set forth in this Agreement have been satisfactorily fulfilled, whichever occurs first.

2. **Performance.** (Must be included)

Cultural specific dancing and singing services.

3. **Background Check.** *(applies to contractors working independent with students)*

Contractor must provide an executed criminal history consent form and a money order or check payable to the District in an amount equal to the actual cost of conducting a criminal history background check on all of its employees assigned to the program. Contractor is precluded from performance of contract until the results of the criminal background check(s) are on file.

If Contractor has already completed background checks for their business needs, Contractor stipulates that the background checks are completed, on file, and will be made available for review if the District should request.

Contractor will notify the District of any individual working in our schools with convictions of a gross misdemeanor or felony.

4. **Reimbursement.** In consideration of the performance of Contractor of its obligations pursuant to this Agreement, District hereby agrees to reimburse Contractor for its services and expenses in performing said obligations up to a sum not to exceed \$ 50 (fifty dollars) per hour_ and \$1000 (one thousand dollars)___ in total.

Contractor is required by Minnesota Statutes, Section 270.66, subd. 3, to provide their Taxpayer Identification Number (TIN) used in the enforcement of Federal and State tax laws. The TIN will

be available to Federal and State tax authorities and State personnel involved in the payment of State obligations. This Agreement will not be approved unless TIN is provided.

5. Requests for Reimbursement. The terms of payment under this Agreement are as follows:

- a. Payment shall be made by the District within 30 days of submission of a proper invoice by the Contractor;
- b. Any other terms of payment in the performance of services are incorporated by reference in this Agreement.

6. Propriety of Expenses. The fact that the District has reimbursed Contractor for any expense claimed by Contractor shall not preclude District from questioning the propriety of any such item. District reserves the right to offset any overpayment or disallowance of any item or items at any time under this Agreement by reducing future payments to Contractor. This clause shall not be construed to bar any other legal remedies District may have to recover funds expended by Contractor for disallowed costs.

7. Ownership of Materials. The District reserves the rights to reproduce the programming in any fashion, or appropriate the contents of the programming, or any portion thereof, to its own use for any and all programs, forms and other materials that Contractor has provided, prepared, or utilized in performance of the terms of this Agreement.

8. Independent Contractor. Both the District and Contractor agree that they will act as an independent contractor in the performance of its duties under this Agreement. Nothing contained in this Agreement shall be construed as in any manner creating a relationship of joint venture between the parties, which shall remain independent contractors with respect to all actions performed pursuant to this Agreement.

Accordingly, Contractor shall be responsible for payment of all taxes, including Federal, State, and local taxes, arising out of Contractor's activities in accordance with this Agreement, including by way of illustration, but not limited to, Federal and State income tax, Social Security tax, Unemployment Insurance taxes, workers compensations, and any other taxes or business license fees as required.

9. Indemnity and defense of the District. Contractor hereby agrees to defend, indemnify and hold the District harmless from all claims relating to its work pursuant to this Agreement.

In the event that Contractor breaches its obligation to defend, indemnify and hold the District harmless, then in addition to its other damages the District shall be entitled to recover its attorney's fees and costs and disbursements incurred in enforcing this Agreement.

10. Notices. All notices to be given by Contractor to District shall be deemed to have been given by depositing the same in writing in the United States Mail: ISD 709, Duluth Public Schools, Attn: Duluth Public Schools , 709 Portia Johnson Drive, Duluth, MN 55811.

All notices to be given by District to Contractor shall be deemed to have been given by depositing the same in writing in the United States Mail to (mailing address with zip)

1020 Glen place Drive Apt 7, Duluth MN 55806

11. Assignment. Contractor shall not in any way assign or transfer any of its rights, interests or obligations under this Agreement in any way whatsoever without the prior written approval of the District.

12. Modification or Amendment. No amendment, change or modification of this Agreement shall be valid unless in writing signed by the parties' hereto.

13. Governing Laws. This Agreement, together with all its paragraphs, terms and provisions is made in the State of Minnesota and shall be construed and interpreted in accordance with the laws of the State of Minnesota.

14. Entire Agreement. This Agreement contains the entire understanding of the parties hereto with respect to the subject matter hereof and shall not be changed or otherwise altered except by written agreement of the parties.

15. Cancellation. Either party shall have the right to terminate this Agreement, without cause, upon (30) days written notice to the other party as provided for in this Agreement.

16. Data Practices. Contractor further understands and agrees that it shall be bound by the Minnesota Government Data Practices Act (Minnesota Statutes 13.03-13.04) with respect to "data on individuals"; as defined in 13.02, subd. 5 of that Statute) which it collects, receives, stores, uses, creates or disseminates pursuant to this Agreement.

17. Insurance. (If applicable) Contractor shall not commence work under the contract until they have obtained all the insurance described below and Duluth Public Schools has approved such insurance. Contractor shall maintain such insurance in force and effect throughout the term of the contract.

Contractor is required to maintain and furnish satisfactory evidence of the following insurance policies:

Workers' Compensation Insurance: Contractor must provide Workers' Compensation insurance for all its employees and, in case any work is subcontracted, Contractor will require the subcontractor to provide Workers' Compensation insurance in accordance with the statutory requirements of the State of Minnesota including Coverage B, Employer's Liability.

Commercial General Liability: Contractor is required to maintain insurance protecting it from claims for damages for bodily injury, including sickness or disease, death, and for care and loss of services as well as claims for property damage, including loss of use which may arise from operations under the Contract whether the operations are by the contractor or subcontractor or by anyone directly or indirectly employed under the contract.

18. **Conflict of Interest and Fiduciary Duty:** All contractors doing business with the District agree to follow Policy 307 - Conflicts of Interest and Fiduciary Duty. This policy is located on the District's website.

THE REMAINDER OF THIS PAGE IS LEFT INTENTIONALLY BLANK

AS EVIDENCE OF THEIR ASSENT TO THE TERMS AND CONDITIONS OF THIS AGREEMENT, set forth above, the parties hereto have caused this Agreement to be executed by their duly authorized officers as of the day and year first above written.

[Signature] _____ [Redacted] 04/30/2026

Contractor Signature _____ SSN/Tax ID Number _____ Date 5/6/26

Program Director _____ Date _____

Please note: All signatures *must* be obtained AND the following *must* be completed by the Program Director before submission to the CFO for review and approval.

This contract is funded by either:

1. The following budget (include full 18 digit code); or
2. will be paid using Student Activity Funds; or
3. is no cost contract (e.g. Memorandum of Understanding).

Please check the appropriate line below:

Check if the contract will be paid using District funds and enter the budget code in the top line below (enter in blank spots following the example).

Check if the contract will be paid using Student Activity Funds

Check if the contract is a no-cost contract such as a Memorandum of Understanding

01	E	005	605	320	305	340
XX	X	XXX	XXX	XXX	XXX	XXX

[Signature] _____ 5.7.26

Exec. Dir Finance & Business Services / Superintendent of Schools / Board Chair _____ Date

**CONTRACT FOR STUDENT NURSING SERVICES
PERTAINING TO [REDACTED]**

This AGREEMENT is made and entered into this 22nd day of April 2026, by **BAYADA Home Health Care, Inc.**, with a service office located at 742 1st Street South, Waite Park, MN 56387 (hereinafter referred to as **BAYADA**) and **ISD 709**, located at 709 Portia Johnson Drive, Duluth, Minnesota 55811, (hereinafter referred to as **SCHOOL**).

BAYADA is a Home Care Agency, licensed to provide services in the states where care is rendered, and **SCHOOL** has identified a need for **STUDENT** nursing care of its student, [REDACTED] (hereinafter referred to as **STUDENT**).

WHEREAS it is the desire of both parties to make provision for nursing services, to include any setting where student is receiving educational services, in accordance with the terms of this Agreement.

THEREFORE, in consideration for the mutual covenants expressed herein, **BAYADA** and **SCHOOL** agree to the terms and conditions outlined herein:

I. RESPONSIBILITIES OF BAYADA

- A. Qualifications of Personnel. The Nurse supplied by **BAYADA** will be a Registered Nurse (RN) or Licensed Practical Nurse (LPN) who will hold a current license, registration or certification as requested by the **SCHOOL** and will provide services pursuant to the applicable state laws.
- B. Personnel Records Inspection. **BAYADA** will make available for inspection, upon the request of **SCHOOL**, the personnel files of its nurses who are caring for **STUDENT**. The contents of such file must include:
1. Verification of current licensure or certification as applicable; and
 2. Completed application for employment or resume; and
 3. Verified references; and
 4. Evidence of annual performance evaluation; and
 5. A criminal record check, conducted upon hire, if required by state law; and
 6. Evidence of at least one annual in-service education or training in accordance with applicable state regulations.
 7. Completed and Verified Sexual Misconduct/Child Abuse Disclosure forms.
 8. Attestation of employee vaccination or exemption status where applicable.
- C. Service. **BAYADA** will provide an RN or LPN to care for **STUDENT** each day that said student attends school. Nursing services will be provided subject to the availability of a qualified nurse. The services to be provided may include escorting **STUDENT** to and from **SCHOOL** on the school transport and providing care to **STUDENT** during the school day. Upon execution of this Agreement, **SCHOOL** will provide **BAYADA** with a schedule of the school calendar including all scheduled days off.
1. **BAYADA** RN Clinical Manager will be responsible for initial and ongoing assessment of **STUDENTS** clinical needs while attending school. Responsibilities include:
 - a. Will work with physician to develop a Plan of Care ("POC") and update the plan per **BAYADA** policy.
 - b. Will conduct supervisory visits to monitor employees and confirm the efficacy of the Plan of Care.

- c. Will collaborate with school nurse and teachers as needed to ensure best possible experience for the **STUDENT**.
 - d. Be ultimately responsible for the **STUDENT's** clinical care under this Agreement.
- D. Place of Performance. **BAYADA** will provide services primarily at schools located within the **SCHOOL's** district to include any setting where student is receiving educational services, in accordance with the terms of this Agreement. **SCHOOL** acknowledges and understands that **BAYADA** cannot guarantee services. All services will be provided subject to the availability of a qualified nurse.
- E. Insurance.
- 1. **BAYADA** will maintain general liability and professional liability coverage for any negligent acts or omissions of **BAYADA** employees, which may give rise to liability under this Agreement.
 - 2. **BAYADA** will maintain Workers' Compensation insurance for its employees providing services to **STUDENT**.
- F. Indemnification. **BAYADA** agrees to indemnify and hold **SCHOOL** harmless with respect to all claims and expenses arising out of, or resulting from, the sole negligence or omission of **BAYADA** or its employees or agents while on assignment to **SCHOOL**.
- G. Equipment and Supplies. **BAYADA** will supply **BAYADA** employee with all Personal Protective Equipment (PPE).
- H. Payment of Personnel. **BAYADA**, as an employer, will remain responsible for the payment of wages and other compensation, reimbursement of expenses and compliance with Federal, State and local tax withholdings, Workers' Compensation, Social Security, employment and other insurance requirements for its personnel.

II. RESPONSIBILITIES OF SCHOOL

- A. Payment for Services. **SCHOOL** will remain responsible to compensate **BAYADA** for services rendered pursuant to this Agreement. Section III hereunder shall govern billing terms and compensation.
- B. Orientation to the school environment. nurses' station; emergency equipment, administrative office, and school geography.
- C. Transport Safety: (If applicable) **SCHOOL** is responsible for ensuring **STUDENT** transport vehicle is safe and **STUDENT** is properly secured in transport vehicle equipment.
- D. Insurance.

 - 1. **SCHOOL** shall maintain at its sole expense valid policies of general liability insurance, covering the negligent acts or omissions of **SCHOOL** acting through its directors, agents, employees or other personnel which may give rise to liability under this Agreement.
 - 2. **SCHOOL** shall maintain, at its sole expense, Workers' Compensation insurance for its employees.

- C. Indemnification. **SCHOOL** agrees to indemnify, defend, and hold **BAYADA** harmless with respect to all claims and expenses arising from, relating to, or resulting from (1) any act or omission of **SCHOOL** or its employees or agents in connection with the performance of this Agreement, (2) those acts of **BAYADA** employees while working under the direction of **SCHOOL**, its staff or its policies or procedures.
- D. Equipment and Supplies. **SCHOOL** will supply **BAYADA**'s RN/LPN with all necessary equipment, tools, materials and supplies necessary to perform services under this Agreement.
- E. Employment Status. **SCHOOL** understands and agrees that the RN/LPN is an employee of **BAYADA**, and **SCHOOL** will not attempt to solicit the RN/LPN to work privately for **SCHOOL**, without written authorization from **BAYADA**, during the term of this Agreement and for one (1) year following its termination or expiration. **SCHOOL** recognizes the recruiting, training and retention expenses that **BAYADA** encounters as an employer and acknowledges that **BAYADA** is not a placement or referral service. Should **SCHOOL** desire to hire one of **BAYADA**'s employees, **SCHOOL** agrees to provide **BAYADA** with written notice and pay a liquidated damages fee equal to four (4) months of the specific employee's annual gross salary or \$10,000.00 whichever is greater. This fee shall apply to any **BAYADA** employee **SCHOOL** wishes to hire.
- F. Compliance Program. **BAYADA** values honesty and confidentiality in all business interactions. **SCHOOL** agrees to report questionable activities involving **BAYADA**'s employees to the local office Director named below or to the Compliance Hotline at 1-866-665-4295.

III. BILLING AND COMPENSATION

- A. **SCHOOL** agrees to compensate **BAYADA** at a rate of \$75.00/hour for RN or \$65.00/hour for LPN services provided under this Agreement. **SCHOOL** will also pay for all time the **BAYADA** employee spends transporting the client to and from **SCHOOL**. **SCHOOL** must provide **BAYADA** with a twenty-four (24) hour cancellation notice or will be subject to charges for services requested.
- B. **BAYADA** will forward to **SCHOOL** an itemized bill on a weekly basis. Each weekly bill will itemize the name of the **BAYADA** employee providing care, the date of service, the type and length of service provided.
- C. **SCHOOL** agrees to pay submitted bills within sixty (60) days of receipt. Any bill not paid within the sixty (60) day period will be considered delinquent. **BAYADA** reserves the right to pursue any collection remedies to resolve a delinquent account. **SCHOOL** agrees to reimburse **BAYADA** for all collection costs, including attorneys' fees and expenses.

IV. TERM AND TERMINATION

- A. This Agreement will come into effect beginning on April 22, 2026 and will remain in effect through May 28, 2026. This Agreement may be extended upon the written consent of each party outlining the terms and time for extension.

- B. Either party may terminate this Agreement, for any reason, upon thirty (30) days prior written notice. If less than thirty (30) day advance notice of cancellation is given, a service charge of fourteen (14) days will be incurred.
- C. Either party may terminate this Agreement for cause due to the occurrence of one of the following events by giving ten (10) days prior written notice:
 - 1. Dissolution or bankruptcy of either **BAYADA** or **SCHOOL**.
 - 2. Failure of either **BAYADA** or **SCHOOL** to maintain the insurance coverages required hereunder.
 - 3. Breach by **BAYADA** or **SCHOOL** of any of the material provisions in this Agreement.

V. ADDITIONAL TERMS

- A. Governing Law. This Agreement will be construed and governed in all respects according to the laws of the State of Minnesota.
- B. Relationship to Parties. The parties enter into this Agreement as independent contractors. Nothing contained in this Agreement will be construed to create a partnership, joint venture, agency or employment relationship between the parties.
- C. Assignment. This Agreement may not be assigned by either party, in whole or in part.
- D. Modification of Terms. No amendments or modifications to the terms of this Agreement will be binding unless evidenced in writing and signed by an authorized representative of each party hereto.
- E. Notices. Any Notice given in connection with this Agreement will be given in writing to the other party, at the party's address listed above. Any party may change its address as stated herein by giving Notice of the change of address in accordance with this Paragraph.
- F. Confidentiality. Except for acknowledging the existence of this Agreement, the parties understand and agree that the terms of this Agreement, including all payment terms, shall be kept confidential unless disclosure is required by law or the parties agree, in writing, to such disclosure. All methods and mode of conduct of business for **SCHOOL** and **BAYADA** are to be kept confidential by **SCHOOL** and **BAYADA** and not disclosed to any other party or used in part or whole without the permission of **SCHOOL** and/or **BAYADA**.
- G. Entire Agreement. This writing evidences the entire Agreement between **BAYADA** and **SCHOOL**; there are no prior written or oral promises or representations incorporated herein. Each Attachment, Fee Schedule, Exhibit or other documents referenced herein and/or attached to this Agreement are incorporated herein as if the same was set out in full in the text of this Agreement. This Agreement may be executed in two or more counterparts, each of which will be deemed an original, but all of which together will constitute one and the same instrument. Delivery of an executed signature page of this Agreement by facsimile or electronic (email) transmission shall be effective as delivery of a manually executed counterpart hereof.

Date: 04/22/2024

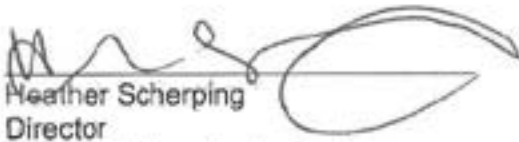

Heather Scherping
Director
Signing with authority for
BAYADA Home Health Care, Inc.

Date: 4/23/26

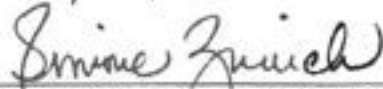

Simone Zurich, Executive Director of
Finance and Business Services
Signing with authority for
ISD 709

Date: 4/22/26

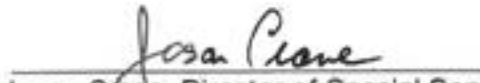

Jason Crane, Director of Special Services Department
Signing with authority for
ISD 709

Budget Code: 01 E 006 412 740 394 000

AGREEMENT

THIS AGREEMENT, made and entered into this 20th day of April, 2026, by Piedmont Elementary and between Independent School District #709, a public corporation, hereinafter called District, and Jes Podpeskar, an independent contractor, hereinafter called Contractor.

THE PURPOSE OF THE AGREEMENT is to set out the terms and conditions whereby Contractor will provide programs or services for the District at the times and locations set forth in this Agreement.

The terms and conditions of this Agreement are as follows: *(insert here or attach as appropriate)*

1. **Dates of Service.** This Agreement shall be deemed to be effective as of 4/20/26 and shall remain in effect until 5/14/26, unless terminated earlier as provided for herein, or unless and until all obligations set forth in this Agreement have been satisfactorily fulfilled, whichever occurs first.

2. **Performance.** Create and run a family bingo night around mental health for Piedmont Elementary school. This will include 3 hours of set up and running the bingo as well as three hours to prep materials.

3. **Background Check.** *(applies to contractors working independent with students)*

Contractor must provide an executed criminal history consent form and a money order or check payable to the District in an amount equal to the actual cost of conducting a criminal history background check on all of its employees assigned to the program. Contractor is precluded from performance of contract until the results of the criminal background check(s) are on file.

If Contractor has already completed background checks for their business needs, Contractor stipulates that the background checks are completed, on file, and will be made available for review if the District should request.

Contractor will notify the District of any individual working in our schools with convictions of a gross misdemeanor or felony.

4. **Reimbursement.** In consideration of the performance of Contractor of its obligations pursuant to this Agreement, District hereby agrees to reimburse Contractor for its services and expenses in performing said obligations \$150 per hour, up to a sum not to exceed \$ 900 in total.

Contractor is required by Minnesota Statutes, Section 270.66, subd. 3, to provide their Taxpayer Identification Number (TIN) used in the enforcement of Federal and State tax laws. The TIN will

be available to Federal and State tax authorities and State personnel involved in the payment of State obligations. This Agreement will not be approved unless TIN is provided.

5. Requests for Reimbursement. The terms of payment under this Agreement are as follows:

- a. Payment shall be made by the District within 30 days of submission of a proper invoice by the Contractor;
- b. Any other terms of payment in the performance of services are incorporated by reference in this Agreement.

6. Propriety of Expenses. The fact that the District has reimbursed Contractor for any expense claimed by Contractor shall not preclude District from questioning the propriety of any such item. District reserves the right to offset any overpayment or disallowance of any item or items at any time under this Agreement by reducing future payments to Contractor. This clause shall not be construed to bar any other legal remedies District may have to recover funds expended by Contractor for disallowed costs.

7. Ownership of Materials. The District reserves the rights to reproduce the programming in any fashion, or appropriate the contents of the programming, or any portion thereof, to its own use for any and all programs, forms and other materials that Contractor has provided, prepared, or utilized in performance of the terms of this Agreement.

8. Independent Contractor. Both the District and Contractor agree that they will act as an independent contractor in the performance of its duties under this Agreement. Nothing contained in this Agreement shall be construed as in any manner creating a relationship of joint venture between the parties, which shall remain independent contractors with respect to all actions performed pursuant to this Agreement.

Accordingly, Contractor shall be responsible for payment of all taxes, including Federal, State, and local taxes, arising out of Contractor's activities in accordance with this Agreement, including by way of illustration, but not limited to, Federal and State income tax, Social Security tax, Unemployment Insurance taxes, workers compensations, and any other taxes or business license fees as required.

9. Indemnity and defense of the District. Contractor hereby agrees to defend, indemnify and hold the District harmless from all claims relating to its work pursuant to this Agreement.

In the event that Contractor breaches its obligation to defend, indemnify and hold the District harmless, then in addition to its other damages the District shall be entitled to recover its attorney's fees and costs and disbursements incurred in enforcing this Agreement.

10. Notices. All notices to be given by Contractor to District shall be deemed to have been given by depositing the same in writing in the United States Mail: ISD 709, Duluth Public Schools, Attn: Sharie Blevins, 709 Portia Johnson Drive, Duluth, MN 55811.

All notices to be given by District to Contractor shall be deemed to have been given by depositing the same in writing in the **United States Mail to Sparrow Psychotherapy at 4140 Richard Ave Hermantown, MN 55811**

11. **Assignment.** Contractor shall not in any way assign or transfer any of its rights, interests or obligations under this Agreement in any way whatsoever without the prior written approval of the District.

12. **Modification or Amendment.** No amendment, change or modification of this Agreement shall be valid unless in writing signed by the parties' hereto.

13. **Governing Laws.** This Agreement, together with all its paragraphs, terms and provisions is made in the State of Minnesota and shall be construed and interpreted in accordance with the laws of the State of Minnesota.

14. **Entire Agreement.** This Agreement contains the entire understanding of the parties hereto with respect to the subject matter hereof and shall not be changed or otherwise altered except by written agreement of the parties.

15. **Cancellation.** Either party shall have the right to terminate this Agreement, without cause, upon (30) days written notice to the other party as provided for in this Agreement.

16. **Data Practices.** Contractor further understands and agrees that it shall be bound by the Minnesota Government Data Practices Act (Minnesota Statutes 13.03-13.04) with respect to "data on individuals"; as defined in 13.02, subd. 5 of that Statute) which it collects, receives, stores, uses, creates or disseminates pursuant to this Agreement.

17. **Insurance.** (If applicable) Contractor shall not commence work under the contract until they have obtained all the insurance described below and Duluth Public Schools has approved such insurance. Contractor shall maintain such insurance in force and effect throughout the term of the contract.

Contractor is required to maintain and furnish satisfactory evidence of the following insurance policies:

Workers' Compensation Insurance: Contractor must provide Workers' Compensation insurance for all its employees and, in case any work is subcontracted, Contractor will require the subcontractor to provide Workers' Compensation insurance in accordance with the statutory requirements of the State of Minnesota including Coverage B, Employer's Liability.

Commercial General Liability: Contractor is required to maintain insurance protecting it from claims for damages for bodily injury, including sickness or disease, death, and for care and loss of services as well as claims for property damage, including loss of use which may arise from

operations under the Contract whether the operations are by the contractor or subcontractor or by anyone directly or indirectly employed under the contract.

18. **Conflict of Interest and Fiduciary Duty:** All contractors doing business with the District agree to follow Policy 307 - Conflicts of Interest and Fiduciary Duty. This policy is located on the District's website.

THE REMAINDER OF THIS PAGE IS LEFT INTENTIONALLY BLANK

AS EVIDENCE OF THEIR ASSENT TO THE TERMS AND CONDITIONS OF THIS AGREEMENT, set forth above, the parties hereto have caused this Agreement to be executed by their duly authorized officers as of the day and year first above written.

Jessie R _____ [REDACTED] 4/20/26

Contractor Signature _____ **SSN/Tax ID Number** _____ **Date**

Katie Butler _____ Dave Sheldon _____ 4/20/26

Program Director _____ **Date**

Please note: All signatures *must* be obtained AND the following *must* be completed by the Program Director before submission to the CFO for review and approval.

This contract is funded by either:

1. The following budget (include full 18 digit code); or
2. will be paid using Student Activity Funds; or
3. is no cost contract (e.g. Memorandum of Understanding).

Please check the appropriate line below:

x Check if the contract will be paid using District funds and enter the budget code in the top line below (enter in blank spots following the example).

Check if the contract will be paid using Student Activity Funds

Check if the contract is a no-cost contract such as a Memorandum of Understanding

01	E	550	216	401	303	638
XX	X	XXX	XXX	XXX	XXX	XXX

Simone Zunic _____ 4/23/26

Exec. Dir Finance & Business Services / Superintendent of Schools / Board Chair _____ **Date**

AGREEMENT

THIS AGREEMENT, made and entered into this 24th day of April, 2026, by and between Independent School District #709, a public corporation, hereinafter called District, and LeAnna Hudson, an independent contractor, hereinafter called Contractor.

THE PURPOSE OF THE AGREEMENT is to set out the terms and conditions whereby Contractor will provide programs or services for the District at the times and locations set forth in this Agreement.

The terms and conditions of this Agreement are as follows: *(insert here or attach as appropriate)*

1. **Dates of Service.** This Agreement shall be deemed to be effective as of August 1, 2026 and shall remain in effect until June 30, 2027, unless terminated earlier as provided for herein, or unless and until all obligations set forth in this Agreement have been satisfactorily fulfilled, whichever occurs first.

2. **Performance.**

1. Determine needs of families and students
2. Meet with families in secondary schools, shelters, safe locations and identify barriers to attending school. Meeting families at their location will expedite the enrollment process and time that children spend unenrolled from school.
3. Collaborate with organizations within the community to meet the needs of youth and share common barriers that the youth face.
4. Have close contact with area youth shelters and assess shelter bed availability, refer for rapid VI-SPDAT assessment for the UHY that are seeking housing opportunities.
5. Help with obtaining vital documents for UHY that do not have access to such documents.
6. Public bus passes and requests for public school transportation via bus or van will also be coordinated as needed from the contracted staff.
7. Consult with the FIT Program Coordinator and FIT team about barriers, resources, and new enrollments within the team assigned schools
8. For the UHY seeking post-secondary education, the contracted staff will assist the Program Coordinator with verification letters needed for college applications, verifying homeless status, as well as assisting youth who are navigating the FAFSA with a homeless designation.
9. Heighten the understanding and sensitivity of educators and specialized instructional support personnel to the needs and rights of homeless children and youth, and the specific educational needs of runaway and homeless youths.
10. Refer homeless children and youth as needed for medical, dental, mental, or other health services.

11. Provide education to the parents and guardians of homeless children and youths about the rights of, and resources available to, such children, as well as other activities designed to increase meaningful involvement of parents and guardians in the education of their homeless children and youths.

3. Background Check. *(applies to contractors working independent with students)*

Contractor must provide an executed criminal history consent form and a money order or check payable to the District in an amount equal to the actual cost of conducting a criminal history background check on all of its employees assigned to the program. Contractor is precluded from performance of contract until the results of the criminal background check(s) are on file.

If Contractor has already completed background checks for their business needs, Contractor stipulates that the background checks are completed, on file, and will be made available for review if the District should request.

Contractor will notify the District of any individual working in our schools with convictions of a gross misdemeanor or felony.

4. Reimbursement. In consideration of the performance of Contractor of its obligations pursuant to this Agreement, District hereby agrees to reimburse Contractor for its services and expenses in performing said obligations up to a sum not to exceed \$40 hourly and \$25,000 in total.

Contractor is required by Minnesota Statutes, Section 270.66, subd. 3, to provide their Taxpayer Identification Number (TIN) used in the enforcement of Federal and State tax laws. The TIN will be available to Federal and State tax authorities and State personnel involved in the payment of State obligations. This Agreement will not be approved unless TIN is provided.

5. Requests for Reimbursement. The terms of payment under this Agreement are as follows:

- a. Payment shall be made by the District within 30 days of submission of a proper invoice by the Contractor;
- b. Any other terms of payment in the performance of services are incorporated by reference in this Agreement.

6. Propriety of Expenses. The fact that the District has reimbursed Contractor for any expense claimed by Contractor shall not preclude District from questioning the propriety of any such item. District reserves the right to offset any overpayment or disallowance of any item or items at any time under this Agreement by reducing future payments to Contractor. This clause shall not be construed to bar any other legal remedies District may have to recover funds expended by Contractor for disallowed costs.

7. Ownership of Materials. The District reserves the rights to reproduce the programming in any fashion, or appropriate the contents of the programming, or any portion thereof, to its own

use for any and all programs, forms and other materials that Contractor has provided, prepared, or utilized in performance of the terms of this Agreement.

8. Independent Contractor. Both the District and Contractor agree that they will act as an independent contractor in the performance of its duties under this Agreement. Nothing contained in this Agreement shall be construed as in any manner creating a relationship of joint venture between the parties, which shall remain independent contractors with respect to all actions performed pursuant to this Agreement.

Accordingly, Contractor shall be responsible for payment of all taxes, including Federal, State, and local taxes, arising out of Contractor's activities in accordance with this Agreement, including by way of illustration, but not limited to, Federal and State income tax, Social Security tax, Unemployment Insurance taxes, workers compensations, and any other taxes or business license fees as required.

9. Indemnity and defense of the District. Contractor hereby agrees to defend, indemnify and hold the District harmless from all claims relating to its work pursuant to this Agreement.

In the event that Contractor breaches its obligation to defend, indemnify and hold the District harmless, then in addition to its other damages the District shall be entitled to recover its attorney's fees and costs and disbursements incurred in enforcing this Agreement.

10. Notices. All notices to be given by Contractor to District shall be deemed to have been given by depositing the same in writing in the United States Mail: ISD 709, Duluth Public Schools, Attn: Lindsay Bruce , 709 Portia Johnson Drive, Duluth, MN 55811.

All notices to be given by District to Contractor shall be deemed to have been given by depositing the same in writing in the United States Mail to (mailing address with zip)

11. Assignment. Contractor shall not in any way assign or transfer any of its rights, interests or obligations under this Agreement in any way whatsoever without the prior written approval of the District.

12. Modification or Amendment. No amendment, change or modification of this Agreement shall be valid unless in writing signed by the parties' hereto.

13. Governing Laws. This Agreement, together with all its paragraphs, terms and provisions is made in the State of Minnesota and shall be construed and interpreted in accordance with the laws of the State of Minnesota.

14. Entire Agreement. This Agreement contains the entire understanding of the parties hereto with respect to the subject matter hereof and shall not be changed or otherwise altered except by written agreement of the parties.

15. **Cancellation.** Either party shall have the right to terminate this Agreement, without cause, upon (30) days written notice to the other party as provided for in this Agreement.

16. **Data Practices.** Contractor further understands and agrees that it shall be bound by the Minnesota Government Data Practices Act (Minnesota Statutes 13.03-13.04) with respect to "data on individuals"; as defined in 13.02, subd. 5 of that Statute) which it collects, receives, stores, uses, creates or disseminates pursuant to this Agreement.

17. **Insurance.** (If applicable) Contractor shall not commence work under the contract until they have obtained all the insurance described below and Duluth Public Schools has approved such insurance. Contractor shall maintain such insurance in force and effect throughout the term of the contract.

Contractor is required to maintain and furnish satisfactory evidence of the following insurance policies:

Workers' Compensation Insurance: Contractor must provide Workers' Compensation insurance for all its employees and, in case any work is subcontracted, Contractor will require the subcontractor to provide Workers' Compensation insurance in accordance with the statutory requirements of the State of Minnesota including Coverage B, Employer's Liability.

Commercial General Liability: Contractor is required to maintain insurance protecting it from claims for damages for bodily injury, including sickness or disease, death, and for care and loss of services as well as claims for property damage, including loss of use which may arise from operations under the Contract whether the operations are by the contractor or subcontractor or by anyone directly or indirectly employed under the contract.

18. **Conflict of Interest and Fiduciary Duty:** All contractors doing business with the District agree to follow Policy 307 - Conflicts of Interest and Fiduciary Duty. This policy is located on the District's website.

THE REMAINDER OF THIS PAGE IS LEFT INTENTIONALLY BLANK

AS EVIDENCE OF THEIR ASSENT TO THE TERMS AND CONDITIONS OF THIS AGREEMENT, set forth above, the parties hereto have caused this Agreement to be executed by their duly authorized officers as of the day and year first above written.

Jenna Hudson [Redacted] 4-24-26

Contractor Signature SSN/Tax ID Number Date

Lindsay Bruce 4/29/26

Program Director
Date

Please note: All signatures *must* be obtained AND the following *must* be completed by the Program Director before submission to the CFO for review and approval.

This contract is funded by either:

1. The following budget (include full 18 digit code); or
2. will be paid using Student Activity Funds; or
3. is no cost contract (e.g. Memorandum of Understanding).

Please check the appropriate line below:

Check if the contract will be paid using District funds and enter the budget code in the top line below (enter in blank spots following the example).

Check if the contract will be paid using Student Activity Funds

Check if the contract is a no-cost contract such as a Memorandum of Understanding

01	E	005	868 803	868	303	180
XX	X	XXX	XXX	XXX	XXX	XXX

Immae Zurch 5/5/26

Exec. Dir Finance & Business Services / Superintendent of Schools / Board Chair Date



WOLF RIDGESM

ENVIRONMENTAL LEARNING CENTER

Program Contract

School Groups

Paul Davis	paul.davis@isd709.org
Lester Park School 5300 Glenwood Street, Duluth MN 55804	Is the Coordinator's name correct? If not, please correct below: New Coordinator name: Email Address:
Deposit: You have made a reservation to stay for September 23, 2026 - September 25, 2026 with 125 participants. To hold your reservation we require a deposit of \$1,875.00. This contract is valid for 30 days after receipt.	
Cancellation Policy: Cancellations require 60 days' notice prior to your scheduled arrival date to receive a full deposit refund. *Notify us immediately if you need to cancel this reservation.	

By signing below, I agree to the terms listed above:

Printed Name: <i>Simone Zunich</i>	Title: <i>Exec. Dir. Business Services</i>	
Signed Name: <i>Simone Zunich</i>	Date: <i>5/5/26</i>	
Billing Contact: <i>AP Vendor</i>	Billing Address: <i>709 Patricia Johnson Dr. Duluth MN 55811</i>	
Billing email address: <i>ap.vendor@isd709.org</i>		
Cardholders Name: <input type="checkbox"/> same as billing contact	Cardholders address: <input type="checkbox"/> same as billing address	
Credit Card #	Exp Date:	CVV:
If unable to pay at this time, when can we expect your deposit?		

Return to: 6282 Cranberry Rd - Finland, MN 55603 or fax to: 218-353-7762

Today's Date: April 27, 2026

AGREEMENT

THIS AGREEMENT, made and entered into this 20th day of April, 2026, by and between Independent School District #709, a public corporation, hereinafter called District, and Tom Wegren, an independent contractor, hereinafter called Contractor.

THE PURPOSE OF THE AGREEMENT is to set out the terms and conditions whereby Contractor will provide programs or services for the District at the times and locations set forth in this Agreement.

The terms and conditions of this Agreement are as follows:

1. **Dates of Service.** This Agreement shall be deemed to be effective as of April 20, 2026 and shall remain in effect until May 8, 2026, unless terminated earlier as provided for herein, or unless and until all obligations set forth in this Agreement have been satisfactorily fulfilled, whichever occurs first.

2. **Performance.** Congdon Spring Concert - Rehearsal Thursday, May 7, 8-2, and 2 performances, Friday, May 8 at 8:30 and 12:30

3. **Background Check.**

Contractor must provide an executed criminal history consent form and a money order or check payable to the District in an amount equal to the actual cost of conducting a criminal history background check on all of its employees assigned to the program. Contractor is precluded from performance of contract until the results of the criminal background check(s) are on file.

If Contractor has already completed background checks for their business needs, Contractor stipulates that the background checks are completed, on file, and will be made available for review if the District should request.

Contractor will notify the District of any individual working in our schools with convictions of a gross misdemeanor or felony.

4. **Reimbursement.** In consideration of the performance of Contractor of its obligations pursuant to this Agreement, District hereby agrees to reimburse Contractor for its services and expenses in performing said obligations up to a sum not to exceed \$250 in total.

Contractor is required by Minnesota Statutes, Section 270.66, subd. 3, to provide their Taxpayer Identification Number (TIN) used in the enforcement of Federal and State tax laws. The TIN will be available to Federal and State tax authorities and State personnel involved in the payment of State obligations. This Agreement will not be approved unless TIN is provided.

5. **Requests for Reimbursement.** The terms of payment under this Agreement are as follows:

- a. Payment shall be made by the District within 30 days of submission of a proper invoice by the Contractor;
- b. Any other terms of payment in the performance of services are incorporated by reference in this Agreement.

6. **Propriety of Expenses.** The fact that the District has reimbursed Contractor for any expense claimed by Contractor shall not preclude District from questioning the propriety of any such item. District reserves the right to offset any overpayment or disallowance of any item or items at any time under this Agreement by reducing future payments to Contractor. This clause shall not be construed to bar any other legal remedies District may have to recover funds expended by Contractor for disallowed costs.

7. **Ownership of Materials.** The District reserves the rights to reproduce the programming in any fashion, or appropriate the contents of the programming, or any portion thereof, to its own use for any and all programs, forms and other materials that Contractor has provided, prepared, or utilized in performance of the terms of this Agreement.

8. **Independent Contractor.** Both the District and Contractor agree that they will act as an independent contractor in the performance of its duties under this Agreement. Nothing contained in this Agreement shall be construed as in any manner creating a relationship of joint venture between the parties, which shall remain independent contractors with respect to all actions performed pursuant to this Agreement.

Accordingly, Contractor shall be responsible for payment of all taxes, including Federal, State, and local taxes, arising out of Contractor's activities in accordance with this Agreement, including by way of illustration, but not limited to, Federal and State income tax, Social Security tax, Unemployment Insurance taxes, workers compensations, and any other taxes or business license fees as required.

9. **Indemnity and defense of the District.** Contractor hereby agrees to defend, indemnify and hold the District harmless from all claims relating to its work pursuant to this Agreement.

In the event that Contractor breaches its obligation to defend, indemnify and hold the District harmless, then in addition to its other damages the District shall be entitled to recover its attorney's fees and costs and disbursements incurred in enforcing this Agreement.

10. **Notices.** All notices to be given by Contractor to District shall be deemed to have been given by depositing the same in writing in the United States Mail: ISD 709, Duluth Public Schools, Attn: **Brett Messing**, 709 Portia Johnson Drive, Duluth, MN 55811.

All notices to be given by District to Contractor shall be deemed to have been given by depositing the same in writing in the United States Mail to (mailing address with zip)

Tom Wegren 102 W. Lewis St. Duluth, MN 55803

11. **Assignment.** Contractor shall not in any way assign or transfer any of its rights, interests or obligations under this Agreement in any way whatsoever without the prior written approval of the District.

12. **Modification or Amendment.** No amendment, change or modification of this Agreement shall be valid unless in writing signed by the parties' hereto.

13. **Governing Laws.** This Agreement, together with all its paragraphs, terms and provisions is made in the State of Minnesota and shall be construed and interpreted in accordance with the laws of the State of Minnesota.

14. **Entire Agreement.** This Agreement contains the entire understanding of the parties hereto with respect to the subject matter hereof and shall not be changed or otherwise altered except by written agreement of the parties.

15. **Cancellation.** Either party shall have the right to terminate this Agreement, without cause, upon (30) days written notice to the other party as provided for in this Agreement.

16. **Data Practices.** Contractor further understands and agrees that it shall be bound by the Minnesota Government Data Practices Act (Minnesota Statutes 13.03-13.04) with respect to "data on individuals"; as defined in 13.02, subd. 5 of that Statute) which it collects, receives, stores, uses, creates or disseminates pursuant to this Agreement.

17. **Insurance.** (If applicable) Contractor shall not commence work under the contract until they have obtained all the insurance described below and Duluth Public Schools has approved such insurance. Contractor shall maintain such insurance in force and effect throughout the term of the contract.

Contractor is required to maintain and furnish satisfactory evidence of the following insurance policies:

Workers' Compensation Insurance: Contractor must provide Workers' Compensation insurance for all its employees and, in case any work is subcontracted, Contractor will require the subcontractor to provide Workers' Compensation insurance in accordance with the statutory requirements of the State of Minnesota including Coverage B, Employer's Liability.

Commercial General Liability: Contractor is required to maintain insurance protecting it from claims for damages for bodily injury, including sickness or disease, death, and for care and loss of services as well as claims for property damage, including loss of use which may arise from operations under the Contract whether the operations are by the contractor or subcontractor or by anyone directly or indirectly employed under the contract.

18. **Conflict of Interest and Fiduciary Duty:** All contractors doing business with the District agree to follow Policy 307 - Conflicts of Interest and Fiduciary Duty. This policy is located on the District's website.

THE REMAINDER OF THIS PAGE IS LEFT INTENTIONALLY BLANK

AS EVIDENCE OF THEIR ASSENT TO THE TERMS AND CONDITIONS OF THIS AGREEMENT, set forth above, the parties hereto have caused this Agreement to be executed by their duly authorized officers as of the day and year first above written.

Roman J. Wegren [Redacted] 4/21/26

Contractor Signature

SSN/Tax ID Number

Date

R. J. [Redacted]

4/21/26

Program Director

Date

Please note: All signatures *must* be obtained AND the following *must* be completed by the Program Director before submission to the CFO for review and approval.

This contract is funded by either:

- 1. The following budget (include full 18 digit code); or
- 2. will be paid using Student Activity Funds; or
- 3. is no cost contract (e.g. Memorandum of Understanding).

Please check the appropriate line below:

Check if the contract will be paid using District funds and enter the budget code in the top line below (enter in blank spots following the example).

Check if the contract will be paid using Student Activity Funds

Check if the contract is a no-cost contract such as a Memorandum of Understanding

01	E	435	298	000	401	421
XX	X	XXX	XXX	XXX	XXX	XXX

Erin Z. [Redacted] 4/23/26

Exec. Dir Finance & Business Services / Superintendent of Schools / Board Chair

Date



Campus Recreation

UWS Campus Recreation
(715) 394-8361 (Wessman Stadium)
(715) 395-4609 (MWC/SCCU Stadium)
campusrec@uwsuper.edu (email)

Facility Use Agreement Form

In consideration of the fees and covenants herein expressed the Board of Regents for the University of Wisconsin on behalf of the University of Wisconsin-Superior, an agency of the State of Wisconsin, herein called the "permitter" does hereby give permission to:

Sponsoring Organization/Group: Ordean East Middle School 8th grade

Contact Person for Events: Jesse Plote

Address: 2900 E 4th St, Duluth, MN 55812 Phone No: 715-864-0014 E-mail: jesse.plote@isf709.org

Herein after called the "permittee", to use University of Wisconsin-Superior facilities described below, between the following hours on the following:

Table with 4 columns: Date of events, Time, Details, Additional Notes. Rows include dates 5/1/2026, 5/15/2026, and 5/29/2026 with details for Mortorelli Gym and Thering Fieldhouse.

For the purpose of: Local Field Experiences Days

With the understanding that all use agreements are subject to the provisions of Wisconsin Administrative Code, Section UWS, and Chapter 21.

This agreement is granted upon the following terms and conditions:

- 1. The permittee shall have the use of the Marcovich Wellness Center: Gym will be set with volleyball, basketball, pickleball, badminton, ping pong, bags and coloring on May 1 and 29. Fieldhouse will be set with volleyball, basketball, soccer, dodgeball, ping pong, bags and coloring on May 15th. There will be 120 sandwich bags of popcorn to go with the kids when they leave each day. The price is a little less this year due to needing to move the groups to the gymnasium on two of the dates. We are sorry about the conflicts.

Rate

Table listing rates for Thering Fieldhouse, Mortorelli Gymnasium, 5% Facility Fee, 360 sandwich bags of popcorn, 5.5% WI Tax, and Total Due of \$2,262.98.

Rate

- 2. The fees to be paid by the permittee to the permitter are in the amounts and on the basis and terms as follows:

Total Price - \$2,262.98 (as itemized above)**There will be a \$100.00 per incident fee assessed for any excessive cleanup.**

- a. Permittee agrees to deposit with the Facility Coordinator of the Marcovich Wellness Center "Facility" at the time of signing this agreement the sum of \$0.00 in cash, certified check or bank cashier's check payable to "UW-Superior Marcovich Wellness Center" and also agrees that all payments due under this agreement shall be made: Before or at the time of such event or within thirty days of receipt of invoice from permitter. (initials SHZ) Permittee agrees that full payment for facility use and additional costs not received by the above mentioned times and dates shall be subject to an interest charge not to exceed 18% annually. It is further agreed that if permittee fails to hold such event or events at the agreed time or times, said permittee shall pay to the permitter the sum of \$1,131.00 as liquidated damages, and that permitter may retain the deposit made hereinabove to apply on said liquidated damages. It is further agreed and understood that the permitter shall have first lien on box-office receipts to cover use fees, incidental expenses and liquidated damages under the terms and conditions of this agreement.
b. Permittee agrees to pay all use fees described in section 1 above due under this contract in cash, certified check, bank cashier's check or by credit card. At the time of making said payment permittee agrees to submit to the Facility Coordinator an itemized and detailed account of the ticket sales and other pertinent information requested by said Facility Coordinator. Permittee agrees to keep adequate financial records acceptable to the Facility Coordinator, together with a list of the first and last ticket numbers sold and agrees to allow a representative of the Permitter to examine said records at any time. Permittee further agrees that the Facility Coordinator may have a representative in the box office.
c. Permittee shall give permitter at least 14 days prior written notification of any/all cancellations of event(s) hereunder. Failure to give such notice will result in permittee paying permitter full payment for the specific cancelled event as scheduled dates/times contracted and stated above.

d. A complete Tax Exempt document confirming exempt status must be provided to the Facility Coordinator if permittee is Tax Exempt in Wisconsin, otherwise permittee's fees hereunder will be taxed. A Certificate of Liability Insurance is also needed and will name permitter as an additional insured. Please provide both of these documents at least 5 days prior to each event scheduled hereunder. All participants will be required to sign a waiver for the climbing wall. (Initials SHZ)

3. Requirements for **criminal background checks are mandatory** for any users who rent facilities from the institution noted in the contract (UW-Superior). Any organization wishing to rent or utilize the institution facilities (indoor and outdoor) must warrant that all employees, staff, or volunteers of their organization have passed a criminal background check to perform their duties as it relates to this contract and working with minors (children 17 years of age and younger). The background check must verify that all employees, staff, or volunteers (paid or unpaid) have no current or pending criminal charges or convictions that render the worker unsuitable for regular contact with children.
4. Permittee shall not televise or broadcast permittee's event without the Facility Coordinator's express prior approval, and if permittee desires to televise or broadcast its event, permittee agrees to pay the permitter an additional fee of N/A for such privilege, and in addition thereto, to pay all costs in connection with the televising or broadcasting of such event.
5. Time shall be of the essence in this agreement and the time herein granted shall not be extended for the occupancy or use of the Facility or for the installation or removal of equipment without the permission of the Facility Coordinator, and all additional time shall be paid for according to the schedule of fees fixed by the Facility Coordinator, if such permission is granted.
6. Permittee agrees that no advertising or other matter shall be placed or posted in or about said described facilities or announced or publicized over any loud speaker system therein without first having obtained the prior written permission of the Facility Coordinator.
7. Permittee agrees to comply with all laws, ordinances and rules applicable to the use of the Facility and to pay all taxes imposed by law in connection with its use and occupancy thereof. Permittee further agrees to abide by and enforce all specified guidelines and regulations governing the Facility and other permitter-owned or controlled properties, including but not limited to grounds and buildings. Smoking is prohibited in the Facility and all other of permitter's buildings including immediately outside of doorways.
8. Permittee agrees that it shall not stage any act or performance in or near the Facility which fire or flame is involved without first seeking written permission from the permitter and City of Superior Fire Department.
9. Permittee agrees that it will not use any decorative materials prohibited by city ordinance including, but not limited to, crepe paper (flameproof or not), cellophane (shredded or not), confetti, cotton, corn stalks, leaves, evergreen boughs, shaves of grain, streamers, straw, paper, vines, moss, coniferous foliage of any similar flammable or combustible materials in or about the Facility.
10. Permittee shall not mar or in any way deface Facility and shall not cause or permit anything to be done whereby Facility is or could reasonable be in any manner mamed, or defaced and will not drive or permit to be driven, nails, hooks, tacks, or screws into any part thereof and will not make or allow to be made any alterations of any kind therein.
11. Erection of special platforms, water tanks, scaffolding, rigging or other apparatus is the sole responsibility of the permittee, but in order to insure safety to the performers, users and the public, shall be installed according to the specifications as determined by the City of Superior Building Inspector and the Facility Coordinator.
12. Permittee agrees that it will not use permitter's equipment, tools, or furnishings, located in or about the Facility, without first applying for and receiving the express approval of the Facility Coordinator.
13. **Permittee understands and agrees that alcoholic beverages will not be brought into the facility and/or consumed on the premises in accordance with Wisconsin State Statutes, Chapter 18.** <https://docs.legis.wisconsin.gov/statutes/statutes/18>
14. Permittee understands and agrees that during the term of this agreement other events may be held in other parts of the Facility or permitter owned or controlled properties and permittee shall so conduct its activities so as not to unreasonably interfere with such other events.

The permittee does hereby agree to hold harmless and indemnify the State of Wisconsin, the Board of Regents of the University of Wisconsin System, and the University of Wisconsin-Superior, their officers, agents, trustees, directors, volunteer workers, assigns, students, and employees, from any and all liability against claims, loss, damages, costs, or expenses, including but not limited to attorney's fees, which are sustained, or incurred, or arising out of the actions in the use of the Facility or permitter owned or controlled properties by the permittee, and for the acts or omissions of directors, officers, employees, contractors or subcontractors, volunteers, participants, guests or any third party for whom it is responsible, regardless of whether or not such claim, damage, loss or expense is caused in part by a party indemnified hereunder. Such an obligation shall not be construed to negate, abridge or reduce other rights or obligations of indemnity that would otherwise exist in the absence of this agreement. Permittee further agrees to and hereby does waive any claim that, except for this waiver, it might otherwise have on account of the inability of permitter for any cause to furnish to permittee the use of the facilities herein described. Permittee further agrees to reimburse the permitter for any damage done to permitter's premises or equipment caused by or arising out of the use and occupancy of permitter's premises by permittee. The agreement in this paragraph 14 contained is one of the considerations upon which this use of facilities is granted.

The Third Party will assume full legal and financial responsibility for any and all damages to institution buildings, facilities and/or equipment used while conducting this program and will be responsible for removal of all personal materials prior to leaving the building or facility at the completion of each program/event. Charges will be assessed to the undersigned for restoration and property removal if applicable. The use of confetti and/or affixing tape to any painted surface is prohibited.

16. Permittee shall not assign or transfer this agreement or sublet any portion thereof without the written consent of the permitter. Each party is an independent contractor and not the agent or employee of the other party and is not and shall not be entitled to benefits afforded to the other party's employees, including but not limited to unemployment and worker's compensation.
17. Both parties agree that this writing constitutes the entire and final agreement between the parties on the subject matter herein.
18. This agreement may be cancelled in whole by the permitter no less than 10 days prior to the event without penalty. The permitter reserves the right to cancel any event at the will of the Chancellor as it pertains to the mission of the permitter or for any other compelling, lawful reason.

If this contract is for an event where minors will be participating in the activity or this is an activity specifically serving minors (youth under age 18), the following additional stipulations apply:

19. The Third Party will comply with the institution's Codes of Ethics as they apply to specific campus employees, including [Wis. Stat. § 19.41 et seq.](#) for Public Officials, [Wis. Admin. Code ch. UWVS 8](#) for Limited Appointees, Faculty, and Academic Staff, and [Recent Policy Document \(RPD\) 20-22](#) for University 304
The Third Party will not offer any officers, employees, or agents any prohibited benefits due to their position at the institution.

20. If the Youth Program is a camp regulated by the Department of Agriculture, Trade, or Consumer Protection (DATCP) under [Wis. Admin. Code ch. ATCP 78](#), the Third Party will comply with the license from DATCP.
21. The Third Party and its officers, employees, and agents will comply with any and all relevant laws, rules, or Institution Policies, including any campus policy required by Youth Protection and Compliance ([System Administrative Policy \(SYS\) 525](#)) as specified in that policy and described below, using the definitions provided in that policy.
22. The Third Party will grant the institution, its employees, agents, and representatives the authority to act in any attempt to safeguard and preserve the health and safety of participants during the use of these facilities including authorizing medical treatment on behalf of participants at the participants expense and of returning the participant to their home.
23. The Third Party waives any claim for damages or compensation resulting from fire, casualty or other circumstances rendering the fulfillment of this agreement impractical or impossible, and understands that the Institution shall not be liable for any resulting loss whatsoever.
24. The third party shall advertise their program as "xxx Camp at UW-Superior" rather than "UW-Superior xxx Camp" so as to mitigate the perception of institutional sponsorship.
25. The Third Party is responsible for completing criminal background checks of all authorized adults, in alignment with [Resant Policy Document 20-19](#), Institution of Wisconsin Criminal Background Check Policy, prior to the commencement of the covered activities.
26. The Third Party will meet the minimum requirements outlined below for any covered activity as defined by the Youth Protection and Compliance Policy [SYS 525](#).
27. **Training.** Authorized adults for third party covered activities shall be trained on the same reporting obligations assigned to UW System employees under Wisconsin Executive Order #54 and in relation to sexual harassment/ sexual violence. Third Parties must train all authorized adults on the content in this section, at minimum, prior to interaction with youth participants in covered activities. Third Parties must also train designated individuals on institutional youth protection best practices, at minimum, prior to interaction with youth participants in covered activities.
28. **Additional Training.** Third Parties may require additional training based on the individual's role or level of risk associated with the covered activity (e.g., duration of program, type of activities) and applicable legal requirements.
29. **Prohibited Behaviors** Third Parties must prohibit behaviors that include, but are not limited to, the following:
 1. Conduct that violates the law (e.g., child abuse, child sexual abuse, protected class discrimination, emotional abuse, hazing, indecent exposure, child pornography, neglect, physical abuse, sexual abuse, and sexual harassment);
 2. Actions that are found to constitute bullying or grooming;
 3. Infringement on privacy of youth participants in situations where they are changing clothes or taking showers except in situations where health and safety require;
 4. Adults showering, bathing, or undressing with or in the presence of youth participants;
 5. Photographing or recording in shower houses, restrooms, or other areas where privacy is expected by participants; and
 6. Use of alcohol when engaged in covered activities.
30. **Supervision Ratios.** Third Parties must require that supervision ratios in covered activities meet the minimum standards set through ATCP 78, with the exception of classroom settings, which allow for a 1:18 Adult to Youth Participant ratio. A minimum of two adults is required for all field trips. Third parties must also include documentation of overnight supervision plans for residential programs.
31. **One-on-One Interactions.** Third Parties must prohibit one-on-one interactions between adults and youth participants, unless the adult is in a setting where one-on-one instruction occurs. In such settings, activities must be observable and interruptible. Exceptions can also be made where a familial relationship exists and in emergency situations.
32. **Overnight Covered Activities.** Third Parties with overnight covered activities must designate staff (paid or unpaid) for the supervision of youth participants overnight and include the following requirements:
 - a. Third party staff must not enter the youth participant's room, bathroom facility, or similar area without another staff except in emergency situations.
 - b. Third party must procure adequate sleeping space so that staff (paid or unpaid) are not sharing sleeping quarters with youth participants during overnight covered activities.
33. **NCAA and Other Governing Authorities.** Third Parties shall comply with youth protection requirements set by the NCAA, any other relevant governing bodies for recruiting activities, and any institutional policies established for the purpose of complying with these requirements.
34. **Emergency Preparedness.** Third Parties must document minimum emergency preparedness protocols based on the covered activity's level of risk and as advised by the institution's risk management authority or other relevant institution stakeholders.
35. **Insurance.** Third Parties must have insurance or other appropriate liability coverage as applicable and approved by the institution's risk management authority, recommended coverage limits include:
 - *Certificate of insurance is required to be presented to verify General Liability and Sexual Abuse/Molestation Liability coverage.*
 - **Workers' Compensation.** The Third Party must carry workers compensation insurance for the third party's employees that meets Wisconsin statutory requirements. <https://dwd.wisconsin.gov/dwd/publications/wc/wfc-7580.htm>
 - **Commercial Comprehensive General Liability.** The Third Party must carry commercial comprehensive general liability insurance coverage of no less than \$1 million for each occurrence and a general aggregate of \$2 million, and includes the following:
 - **Sexual Abuse/Molestation Liability.** The Third Party must carry sexual abuse and/or molestation liability insurance coverage of no less than \$1 million for each occurrence and a general aggregate of \$2 million. <https://ucamps.mains.com/policy-limits-and-coverage/>
 - Policy must not contain any exclusion for abuse from sexual, emotional or physical actions and/or misconduct. If such exclusions are included, separate coverage must be purchased and evidenced.
 - **Automobile Liability.** The Third Party must carry automobile liability insurance coverage with a combined single limit of no less than \$1 million when automobiles are used to transport youth or perform other third-party operations while on campus.

- **Damage to Rented Premises.** The Third Party must carry damages to rented premises insurance coverage of no less than \$100,00.
- **Medical Payments.** Third Party is required to carry medical payments coverage of non-participants. Limits must be no less than \$5,000.
- **Occurrence basis.** The policy must be written on an occurrence basis, or if claims-made coverage is provided, coverage must be maintained for a minimum of five (5) years after the termination the program.
- Policy must cover all activities to be performed by the external party, including athletic/physical activities.
- Policy must not contain any exclusion for intentional acts.
- Shall be provided by a carrier with a minimum A.M. Best rating of A-.
- All insurance required Workers Compensation, shall contain a waiver of subrogation in favor of "Board of Regents of the Institution of Wisconsin System, its officers, employees, and agents."
- Insurance shall be primary and noncontributory.
- Board of Regents of the Institution of Wisconsin System shall be named as additional insured.
(initials SHZ)

36. **Monitoring and Reporting.** Third Parties must require all covered activities youth serving staff (paid or unpaid) to monitor and report according to applicable law. Reporting must include, but is not limited to requiring all adults covered under this policy to report:

- Any suspected physical abuse, neglect, or sexual abuse of a minor in alignment with Wisconsin Executive Order #54;
- Sexual harassment or sexual violence as defined by the institution's Title IX policy;
- Incidents resulting in serious harm requiring professional medical attention; and
- Incidents of illegal or unauthorized drug use.
- Third Parties shall report incidents involving sexual abuse, sexual harassment, sexual violence and serious harm requiring professional medical attention to the institution in accordance with the institution's escalation plan.

37. **Registration.** Third Parties taking custodial care must have a registration process for covered activities. For covered activities the following registration information, at a minimum, must be collected:

- Date(s)/time(s) of covered activity
- Primary contact for covered activity
- Staff (Paid or unpaid): Names, contact information, screening, training
- Participant registration information collected must include:
 - Name
 - Contact information, including emergency contact information

38. **Non-Custodial Care Registration.** For Third-Party covered activities in which custodial care is not taken the following registration process as minimum must collect the following:

- Date(s)/time(s) of covered activity
- Primary contact for covered activity

39. **Audit.** All requirements for covered activities are subject to audits and or request(s) and may occur at any time within seven years.

40. Violations of this agreement and/or associated policies, protocols, or procedures by the Third Party may subject the Third Party to program termination, and its employees, officers, and agents to removal from the authorization to work with minors, in accordance with institutional policies and procedures.

IN WITNESS WHEREOF, the parties have caused this agreement to be signed by their respective authorized signatories on the same day and date below written.

For the Board of Regents for the University of Wisconsin on behalf of University of Wisconsin Superior:

Name Krisi Patterson

Signature 

Title Director, Campus Recreation

For the permittee:

Name Simone Zurich

Signature 

Title Exec. Dir. of Business Services ISD709

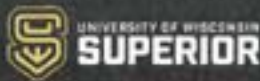

Campus Recreation

UWS Campus Recreation
 (715) 394-8361 (Wessman Stadium)
 (715) 395-4609 (MWC/SCCU Stadium)
 campusrec@uwsuper.edu (email)

Facility Use Agreement Form

In consideration of the fees and covenants herein expressed the Board of Regents for the University of Wisconsin on behalf of the University of Wisconsin-Superior, an agency of the State of Wisconsin, herein called the "permitter" does hereby give permission to:

Sponsoring Organization/Group: Ordean East Middle School 6th Grade

Contact Person for Events: Stephanie Kiero

Address: 2900 E 4th St, Duluth, MN 55812 Phone No: 218-336-8940 E-mail: simone.zunich@isd709.org stephanie.kiero@isd708.org

Herein after called the "permittee", to use University of Wisconsin-Superior facilities described below, between the following hours on the following:

Date of events	Time	Details	Additional Notes
5/29/2026	12pm - 2pm	Full Fieldhouse	

For the purpose of: Ordean East MS 6th grade students Fun Day

With the understanding that all use agreements are subject to the provisions of Wisconsin Administrative Code, Section UWS, and Chapter 21.

This agreement is granted upon the following terms and conditions:

1. The permittee shall have the use of the Marcovich Wellness Center:

Tharing Fieldhouse - courts set for basketball, volleyball, dodgeball and soccer. Bags and ping pong on the side. roughly 90 students

Rate

Full FH rental at \$185.00/hr X 2 hrs	= 370.00
5% Facility Fee	= 18.50
5.5% WI Tax	= 21.37
Total Due	= \$409.87

Rate

2. The fees to be paid by the permittee to the permitter are in the amounts and on the basis and terms as follows:

Total Price - \$409.87 (as Itemized above)There will be a \$100.00 per incident fee assessed for any excessive cleanup.****

- a. Permittee agrees to deposit with the Facility Coordinator of the Marcovich Wellness Center "Facility" at the time of signing this agreement the sum of \$0.00 in cash, certified check or bank cashier's check payable to "UW-Superior Marcovich Wellness Center " and also agrees that all payments due under this agreement shall be made: Before or at the time of such event or within thirty days of receipt of invoice from permitter. (initials SHZ) Permittee agrees that full payment for facility use and additional costs not received by the above mentioned times and dates shall be subject to an interest charge not to exceed 18% annually. It is further agreed that if permittee fails to hold such event or events at the agreed time or times, said permittee shall pay to the permitter the sum of \$204.00 as liquidated damages, and that permitter may retain the deposit made hereinabove to apply on said liquidated damages. It is further agreed and understood that the permitter shall have first lien on box-office receipts to cover use fees, incidental expenses and liquidated damages under the terms and conditions of this agreement.
- b. Permittee agrees to pay all use fees described in section 1 above due under this contract in cash, certified check, bank cashier's check or by credit card. At the time of making said payment permittee agrees to submit to the Facility Coordinator an itemized and detailed account of the ticket sales and other pertinent information requested by said Facility Coordinator. Permittee agrees to keep adequate financial records acceptable to the Facility Coordinator, together with a list of the first and last ticket numbers sold and agrees to allow a representative of the Permitter to examine said records at any time. Permittee further agrees that the Facility Coordinator may have a representative in the box office.
- c. Permittee shall give permitter at least 14 days prior written notification of any/all cancellations of event(s) hereunder. Failure to give such notice will result in permittee paying permitter full payment for the specific cancelled event as scheduled dates/times contracted and stated above.
- d. A complete Tax Exempt document confirming exempt status must be provided to the Facility Coordinator if permittee is Tax Exempt in Wisconsin, otherwise permittee's fees hereunder will be taxed. A Certificate of Liability Insurance is also needed and will name permitter as an additional insured. Please provide both of these documents at least 5 days prior to each event scheduled hereunder. All participants will be required to sign a waiver for the climbing wall. (initials SHZ)

3. Requirements for criminal background checks are mandatory for any users who rent facilities from the institution noted in the contract (UW-Superior) 394y organization wishing to rent or utilize the institution facilities (indoor and outdoor) must warrant that all employees, staff, or volunteers of their organization have passed a criminal background check to perform their duties as it relates to this contract and working with minors (children 17 years of age and younger). The background

check must verify that all employees, staff, or volunteers (paid or unpaid) have no current or pending criminal charges or convictions that render the worker unsuitable for regular contact with children.

4. Permittee shall not televise or broadcast permittee's event without the Facility Coordinator's express prior approval, and if permittee desires to televise or broadcast its event, permittee agrees to pay the permitter an additional fee of N/A for such privilege, and in addition thereto, to pay all costs in connection with the televising or broadcasting of such event.
5. Time shall be of the essence in this agreement and the time herein granted shall not be extended for the occupancy or use of the Facility or for the installation or removal of equipment without the permission of the Facility Coordinator, and all additional time shall be paid for according to the schedule of fees fixed by the Facility Coordinator, if such permission is granted.
6. Permittee agrees that no advertising or other matter shall be placed or posted in or about said described facilities or announced or publicized over any loud speaker system therein without first having obtained the prior written permission of the Facility Coordinator.
7. Permittee agrees to comply with all laws, ordinances and rules applicable to the use of the Facility and to pay all taxes imposed by law in connection with its use and occupancy thereof. Permittee further agrees to abide by and enforce all specified guidelines and regulations governing the Facility and other permitter-owned or controlled properties, including but not limited to grounds and buildings. Smoking is prohibited in the Facility and all other of permitter's buildings including immediately outside of doorways.
8. Permittee agrees that it shall not stage any act or performance in or near the Facility which fire or flame is involved without first seeking written permission from the permitter and City of Superior Fire Department.
9. Permittee agrees that it will not use any decorative materials prohibited by city ordinance including, but not limited to, crepe paper (flameproof or not), cellophane (shredded or not), confetti, cotton, corn stalks, leaves, evergreen boughs, shaves of grain, streamers, straw, paper, vines, moss, coniferous foliage of any similar flammable or combustible materials in or about the Facility.
10. Permittee shall not mar or in any way deface Facility and shall not cause or permit anything to be done whereby Facility is or could reasonable be in any manner marred, or defaced and will not drive or permit to be driven, nails, hooks, tacks, or screws into any part thereof and will not make or allow to be made any alterations of any kind therein.
11. Erection of special platforms, water tanks, scaffolding, rigging or other apparatus is the sole responsibility of the permittee, but in order to insure safety to the performers, users and the public, shall be installed according to the specifications as determined by the City of Superior Building Inspector and the Facility Coordinator.
12. Permittee agrees that it will not use permitter's equipment, tools, or furnishings, located in or about the Facility, without first applying for and receiving the express approval of the Facility Coordinator.
13. **Permittee understands and agrees that alcoholic beverages will not be brought into the facility and/or consumed on the premises in accordance with Wisconsin State Statutes, Chapter 18.** <https://docs.legis.wisconsin.gov/statutes/statutes/18>
14. Permittee understands and agrees that during the term of this agreement other events may be held in other parts of the Facility or permitter owned or controlled properties and permittee shall so conduct its activities so as not to unreasonably interfere with such other events.

The permittee does hereby agree to hold harmless and indemnify the State of Wisconsin, the Board of Regents of the University of Wisconsin System, and the University of Wisconsin-Superior, their officers, agents, trustees, directors, volunteer workers, assigns, students, and employees, from any and all liability against claims, loss, damages, costs, or expenses, including but not limited to attorney's fees, which are sustained, or incurred, or arising out of the actions in the use of the Facility or permitter owned or controlled properties by the permittee, and for the acts or omissions of directors, officers, employees, contractors or subcontractors, volunteers, participants, guests or any third party for whom it is responsible, regardless of whether or not such claim, damage, loss or expense is caused in part by a party indemnified hereunder. Such an obligation shall not be construed to negate, abridge or reduce other rights or obligations of indemnity that would otherwise exist in the absence of this agreement. Permittee further agrees to and hereby does waive any claim that, except for this waiver, it might otherwise have on account of the inability of permitter for any cause to furnish to permittee the use of the facilities herein described. Permittee further agrees to reimburse the permitter for any damage done to permitter's premises or equipment caused by or arising out of the use and occupancy of permitter's premises by permittee. The agreement in this paragraph 14 contained is one of the considerations upon which this use of facilities is granted.

The Third Party will assume full legal and financial responsibility for any and all damages to institution buildings, facilities and/or equipment used while conducting this program and will be responsible for removal of all personal materials prior to leaving the building or facility at the completion of each program/event. Charges will be assessed to the undersigned for restoration and property removal if applicable. The use of confetti and/or affixing tape to any painted surface is prohibited.

16. Permittee shall not assign or transfer this agreement or sublet any portion thereof without the written consent of the permitter. Each party is an independent contractor and not the agent or employee of the other party and is not and shall not be entitled to benefits afforded to the other party's employees, including but not limited to unemployment and worker's compensation.
17. Both parties agree that this writing constitutes the entire and final agreement between the parties on the subject matter herein.
18. This agreement may be cancelled in whole by the permitter no less than **10 days** prior to the event without penalty. The permitter reserves the right to cancel any event at the will of the Chancellor as it pertains to the mission of the permitter or for any other compelling, lawful reason.

If this contract is for an event where minors will be participating in the activity or this is an activity specifically serving minors (youth under age 18), the following additional stipulations apply:

19. The Third Party will comply with the institution's Codes of Ethics as they apply to specific campus employees, including [Wis. Stat. § 19.41 et seq](#) for Public Officials, [Wis. Admin. Code ch. UWYS 8](#) for Limited Appointees, Faculty, and Academic Staff, and [Regent Policy Document \(RPD\) 20-22](#) for University Staff. The Third Party will not offer any officers, employees, or agents any prohibited benefits due to their position at the institution.
20. If the Youth Program is a camp regulated by the Department of Agriculture, Trade, or Consumer Protection (DATCP) under [Wis. Admin. Code ch. ATCP 78](#), the Third Party will comply with the license from DATCP.
21. The Third Party and its officers, employees, and agents will comply with any and all relevant laws, rules, or Institution Policies, including any campus policy required by Youth Protection and Compliance ([System Administrative Policy \(SYS\) 625](#)) as specified in that policy and described below, using the definitions provided in that policy.
22. The Third Party will grant the institution, its employees, agents, and representatives the authority to act in any attempt to safeguard and preserve the health and safety of participants during the use of these facilities including authorizing medical treatment on behalf of participants at the participants expense and of

returning the participant to their home.

23. The Third Party waives any claim for damages or compensation resulting from fire, casualty or other circumstances rendering the fulfillment of this agreement impractical or impossible, and understands that the Institution shall not be liable for any resulting loss whatsoever.
24. The third party shall advertise their program as "xxx Camp at UW-Superior" rather than "UW-Superior xxx Camp" so as to mitigate the perception of institutional sponsorship.
25. The Third Party is responsible for completing criminal background checks of all authorized adults, in alignment with [Regent Policy Document 20-19](#), Institution of Wisconsin Criminal Background Check Policy, prior to the commencement of the covered activities.
26. The Third Party will meet the minimum requirements outlined below for any covered activity as defined by the Youth Protection and Compliance Policy [SYS 625](#).
27. **Training.** Authorized adults for third party covered activities shall be trained on the same reporting obligations assigned to UW System employees under Wisconsin Executive Order #54 and in relation to sexual harassment/ sexual violence. Third Parties must train all authorized adults on the content in this section, at minimum, prior to interaction with youth participants in covered activities. Third Parties must also train designated individuals on institutional youth protection best practices, at minimum, prior to interaction with youth participants in covered activities.
28. **Additional Training.** Third Parties may require additional training based on the individual's role or level of risk associated with the covered activity (e.g., duration of program, type of activities) and applicable legal requirements.
29. **Prohibited Behaviors** Third Parties must prohibit behaviors that include, but are not limited to, the following:
 1. Conduct that violates the law (e.g., child abuse, child sexual abuse, protected class discrimination, emotional abuse, hazing, indecent exposure, child pornography, neglect, physical abuse, sexual abuse, and sexual harassment);
 2. Actions that are found to constitute bullying or grooming;
 3. Infringement on privacy of youth participants in situations where they are changing clothes or taking showers except in situations where health and safety require;
 4. Adults showering, bathing, or undressing with or in the presence of youth participants;
 5. Photographing or recording in shower houses, restrooms, or other areas where privacy is expected by participants; and
 6. Use of alcohol when engaged in covered activities.
30. **Supervision Ratios.** Third Parties must require that supervision ratios in covered activities meet the minimum standards set through ATCP 78, with the exception of classroom settings, which allow for a 1:18 Adult to Youth Participant ratio. A minimum of two adults is required for all field trips. Third parties must also include documentation of overnight supervision plans for residential programs.
31. **One-on-One Interactions.** Third Parties must prohibit one-on-one interactions between adults and youth participants, unless the adult is in a setting where one-on-one instruction occurs. In such settings, activities must be observable and interruptible. Exceptions can also be made where a familial relationship exists and in emergency situations.
32. **Overnight Covered Activities.** Third Parties with overnight covered activities must designate staff (paid or unpaid) for the supervision of youth participants overnight and include the following requirements:
 - a. Third party staff must not enter the youth participant's room, bathroom facility, or similar area without another staff except in emergency situations.
 - b. Third party must procure adequate sleeping space so that staff (paid or unpaid) are not sharing sleeping quarters with youth participants during overnight covered activities.
33. **NCAA and Other Governing Authorities.** Third Parties shall comply with youth protection requirements set by the NCAA, any other relevant governing bodies for recruiting activities, and any institutional policies established for the purpose of complying with these requirements.
34. **Emergency Preparedness.** Third Parties must document minimum emergency preparedness protocols based on the covered activity's level of risk and as advised by the institution's risk management authority or other relevant institution stakeholders.
35. **Insurance.** Third Parties must have insurance or other appropriate liability coverage as applicable and approved by the institution's risk management authority, recommended coverage limits include:
 - *Certificate of insurance is required to be presented to verify General Liability and Sexual Abuse/Molestation Liability coverage.*
 - *Workers' Compensation.* The Third Party must carry workers compensation insurance for the third party's employees that meets Wisconsin statutory requirements. <https://dwd.wisconsin.gov/worker/publications/hcwhkn-7580.htm>
 - *Commercial Comprehensive General Liability.* The Third Party must carry commercial comprehensive general liability insurance coverage of no less than \$1 million for each occurrence and a general aggregate of \$2 million, and includes the following:

Sexual Abuse/Molestation Liability. The Third Party must carry sexual abuse and/or molestation liability insurance coverage of no less than \$1 million for each occurrence and a general aggregate of \$2 million. <https://ucamps.mains.com/policy-limits-and-coverage/>

Policy must not contain any exclusion for abuse from sexual, emotional or physical actions and/or misconduct. If such exclusions are included, separate coverage must be purchased and evidenced.
 - *Automobile Liability.* The Third Party must carry automobile liability insurance coverage with a combined single limit of no less than \$1 million when automobiles are used to transport youth or perform other third-party operations while on campus.
 - *Damage to Rented Premises.* The Third Party must carry damages to rented premises insurance coverage of no less than \$100,00.
 - *Medical Payments.* Third Party is required to carry medical payments coverage of non-participants. Limits must be no less than \$5,000.
 - *Occurrence Basis.* The policy must be written on an occurrence basis, or if claims-made coverage is provided, coverage must be maintained for a minimum of five (5) years after the termination the program.
 - *Policy must cover all activities to be performed by the external party, including athletic/physical activities.*
 - *Policy must not contain any exclusion for intentional acts.*
 - *Shall be provided by a carrier with a minimum A.M. Best rating of A-.*
 - *All insurance required Workers Compensation, shall contain a waiver of subrogation in favor of "Board of Regents of the Institution of Wisconsin System, its officers, employees, and agents."*

- Insurance shall be primary and noncontributory.
- Board of Regents of the Institution of Wisconsin System shall be named as additional insured. (initials SHZ)

36. **Monitoring and Reporting.** Third Parties must require all covered activities youth serving staff (paid or unpaid) to monitor and report according to applicable law. Reporting must include, but is not limited to requiring all adults covered under this policy to report:

- Any suspected physical abuse, neglect, or sexual abuse of a minor in alignment with Wisconsin Executive Order #54;
- Sexual harassment or sexual violence as defined by the institution's Title IX policy;
- Incidents resulting in serious harm requiring professional medical attention; and
- Incidents of illegal or unauthorized drug use.
- Third Parties shall report incidents involving sexual abuse, sexual harassment, sexual violence and serious harm requiring professional medical attention to the institution in accordance with the institution's escalation plan.

37. **Registration.** Third Parties taking custodial care must have a registration process for covered activities. For covered activities the following registration information, at a minimum, must be collected:

- Date(s)/time(s) of covered activity
- Primary contact for covered activity
- Staff (Paid or unpaid): Names, contact information, screening, training
- Participant registration information collected must include:
 - Name
 - Contact information, including emergency contact information

38. **Non-Custodial Care Registration.** For Third-Party covered activities in which custodial care is not taken the following registration process as minimum must collect the following:

- Date(s)/time(s) of covered activity
- Primary contact for covered activity

39. **Audit.** All requirements for covered activities are subject to audits and or request(s) and may occur at any time within seven years.

40. Violations of this agreement and/or associated policies, protocols, or procedures by the Third Party may subject the Third Party to program termination, and its employees, officers, and agents to removal from the authorization to work with minors, in accordance with institutional policies and procedures.

IN WITNESS WHEREOF, the parties have caused this agreement to be signed by their respective authorized signatories on the same day and date below written.

For the Board of Regents for the University of Wisconsin on behalf of University of Wisconsin Superior:

Name Krisl Patterson

Signature 

Title Director, Campus Recreation

For the permittee:

Name Simone Zurich

Signature 

Title Exec. Dir. of Business Services ISD709

Date last revised: February 22, 2024 - Vice Chancellor Admin & Finance

Participants	Signature	Completed	Status	Result	Comments
Initiator Donya Shehan-King		4/28/2026 1:10 PM	Completed		
Customer Signature		4/28/2026 1:10 PM			

**No Cost Contracts Signed
April 2026**

For your information, the Superintendent or the Executive Director of Business Services has signed the following no cost contracts during the above timeframe:

Name	Contract Source	Description
Northeast Service Cooperative	CTE/TLE	Digital Marketing externship with Zac Carlson Creative LLC – NESC reimburses the district for the cost of the externship
Northeast Service Cooperative	CTE/TLE	Agate Acres and Duluth East HS partnership – NESC reimburses the district for the cost of the externship
The College of St. Scholastica – Upward Bound	TLE	Data Sharing Agreement for Release of Data Under “School Official” Exception – The College of St. Scholastica, Upward Bound, will provide education support to the district for the 2026-2027 school year
The College of St. Scholastica – Trio Talent Search	TLE	Data Sharing Agreement for Release of Data Under “School Official” Exception – The College of St. Scholastica, Trio Talent Search, will provide education support to the district for the 2026-2027 school year
FY 2026 Annual Plan Agreement – State of Minnesota Department of Children, Youth and Families	Early Childhood	Attend a one hour project orientation, participate in initial conversations with the State of Minnesota, assemble a group of key reps of various ECCE programs in the community, coordinate and engage in various events supporting ECCE



**Application & Reimbursement Request
FY 2025 - 2026**

**Career & Technical Education Grant
Externships / Professional Development Request**

Basic Project Information and Externship Details

For Office Use: UFARS Code 305 Costs



Approximately \$25,000 will be available to fund Teacher Externship opportunities. The grant period is from April 2026 through June 2026 or until funding runs out.

THE DEADLINE FOR APPLICATIONS IS APRIL 24, 2026

GRANT APPROVAL COMMITTEE: NESC CTE Budget Committee:

Email Applications to John Engelking - NESC

APPROVAL COMMITTEE: NESC CTE

Subcommittee: Danette Seboe, Scott Patrow, Kristi Berlin, Shannon Malovrh, John Engelking

The Rural CTE Grant will fund externship grants of 80 to 200 hours. The hourly pay rate is typically \$30.00 / hour = 200 X \$30.00 = 6,000 plus 16% in benefits. Districts are limited to \$7,000 per academic year, and this may be reduced and equitably distributed to accommodate more requests. Externship grants are available only to licensed CTE instructors. Teachers must complete an Externship Application, which requires them to indicate their business partner. The Budget Committee will review applications and provide notice of approval. Requests for NESC payment are due by July 1, 2026.

IF APPROVED, SUBMIT REIMBURSEMENT REQUEST, INVOICE, AND SUPPORTING DOCUMENTS TO:

Kathy Jankila and John Engelking

Name of the proposed CTE Externship Project or Projects.	
Digital Marketing externship with Zac Carlson Creative LLC	
If approved, please indicate the teacher's willingness to share their experience at a future CTE educational summit or meeting. (Yes or No)	
Primary Project Contact Name/Email/Phone:	
Zac Carlson / zaccarlsonphoto@gmail.com / 1-763-242-0709	
Teacher(s) Assigned to Externships Name/Email/Phone:	
Cameron Kolodge / cameron.kolodge@isd709.org / 1-218-590-2077	
Primary Project School:	
Duluth East High School	
Primary Partners (businesses or industries) Marketing, Branding, Public Relations, Social Media Strategy,	

District Number :	ISD709
Proposed Project Start Date:	Could start remote May 1, 2026 otherwise in person June 6th 2026
Projected number of students impacted as a result of the Externship	~300 per year. Utilizing this experience as real world examples to explain related concepts to students.
Project Grade Level(s) Impacted:	9-12
Describe the activities, goals, and intended outcomes/student impact:	<p>Activities: I will assist with four concurrent contract projects involving Social Media Branding with alignment to the brand mission, image, and target markets. I will also learn the pricing, legal structures, and internal branding/marketing of the host company.</p> <p>Goals: Gain broad understanding of the rebranding process, gain technological understanding of the general industry, understand the process of pitching to clients.</p> <p>Outcomes/Student Impact: Use this knowledge to brand the newly developed school store, Deca communications, and Business Education department in general. Share my first hand knowledge of these projects with students to show the real world application of what we are learning in class.</p>
Indicate if this externship was previously funded and the source of that funding.	Hoping to gain funding from the FY 2025 - 2026 Career & Technical Education Grant Externships / Professional Development Request
Hourly Rate and Total Requested Funding. (IE, The hourly pay rate is typically \$30.00 / hour = 200 X \$30.00 = 6,000 plus 16% in benefits. Amount:	My host has the contract work lined up to accommodate up to 200 hours for the externship but I will take whatever is available @\$30/hr. I am hoping for at least 80 hours to have a meaningful experience.

Certification & Assurances

I certify that the information in this application is true and correct to the best of my knowledge and belief, and that I have the authority to apply for the requested award and in the amount requested.

Simone Zurich
 Signature of Business Manager

 Signature of Authorized Supervisor

Simone Zurich
 Printed Name

 Printed Name

Exec. Dir. Finance & Business Serv.
 Title

 Title

4/14/26
 Date

 Date



**Application & Reimbursement Request
FY 2025 - 2026
Career & Technical Education Grant
Externships / Professional Development Request**
Basic Project Information and Externship Details
For Office Use: UFARS Code 305 Costs

Approximately \$25,000 will be available to fund Teacher Externship opportunities. The grant period is from April 2026 through June 2026 or until funding runs out.

THE DEADLINE FOR APPLICATIONS IS APRIL 24, 2026

GRANT APPROVAL COMMITTEE: NESC CTE Budget Committee:

[Email Applications to John Engelking - NESC](mailto:john.engelking@nesc.org)

APPROVAL COMMITTEE: NESC CTE

Subcommittee: Danette Seboe, Scott Patrow, Kristi Berlin, Shannon Malovrh, John Engelking

The Rural CTE Grant will fund externship grants of 80 to 200 hours. The hourly pay rate is typically \$30.00 / hour = 200 X \$30.00 = 6,000 plus 16% in benefits. **Districts are limited to \$7,000 per academic year**, and this may be reduced and equitably distributed to accommodate more requests. Externship grants are available only to licensed CTE instructors. Teachers must complete an Externship Application, which requires them to indicate their business partner. The Budget Committee will review applications and provide notice of approval. Requests for NESC payment are due by July 1, 2026.

IF APPROVED, SUBMIT REIMBURSEMENT REQUEST, INVOICE, AND SUPPORTING DOCUMENTS TO:

[Kathy Jankila and John Engelking](mailto:kathy.jankila@nesc.org)

<p>Name of the proposed CTE Externship Project or Projects. Agate Acres and Duluth East Partnership</p>	
<p>If approved, please indicate the teacher's willingness to share their experience at a future CTE educational summit or meeting. Yes</p>	
<p>Primary Project Contact Name/Email/Phone: Sonja Hakanson, sonja.hakanson@isd709.org, 608-408-0437</p>	
<p>Teacher(s) Assigned to Externships Name/Email/Phone: Sonja Hakanson, sonja.hakanson@isd709.org, 608-408-0437</p>	
<p>Primary Project School: Duluth East High School, Duluth MN</p>	

Primary Partners (businesses or industries) Agate Acres, Two Harbors MN	
District Number :	709
Proposed Project Start Date:	5/01/2026
Projected number of students impacted as a result of the Externship	100+
Project Grade Level(s) Impacted:	9-12
Describe the activities, goals, and intended outcomes/student impact:	
Indicate if this externship was previously funded and the source of that funding.	No
Hourly Rate and Total Requested Funding. (IE, The hourly pay rate is typically \$30.00 / hour = 200 X \$30.00 = 6,000 plus 16% in benefits. Amount:	\$30.00 X 80 = 2,400 plus 16% in benefits = \$2784.00

Certification & Assurances

I certify that the information in this application is true and correct to the best of my knowledge and belief, and that I have the authority to apply for the requested award and in the amount requested.

Simone Zunic
 Signature of Business Manager

 Signature of Authorized Supervisor

Simone Zunic
 Printed Name

 Printed Name

Exec. Dir. Finance, Business Services
 Title

 Title

4/20/26
 Date

 Date



**DATA SHARING AGREEMENT FOR RELEASE
OF DATA UNDER "SCHOOL OFFICIAL" EXCEPTION**

This Data Sharing Agreement ("Agreement") between Independent School District No. 709, Duluth Public Schools ("District") and THE COLLEGE OF ST. SCHOLASTICA, UPWARD BOUND, is entered into as of July 1, 2026 ("Effective Date"). The District and THE COLLEGE OF ST. SCHOLASTICA, UPWARD BOUND are referred to collectively as the "Parties."

WHEREAS, certain individuals affiliated with THE COLLEGE OF ST. SCHOLASTICA, UPWARD BOUND (hereinafter "Requesting Entity") will provide *EDUCATIONAL SUPPORT* to the District for the 2026-2027 school year; and

WHEREAS, the services to be provided by individuals affiliated with Requesting Entity are institutional services and functions for which the District would otherwise use its own employees; and

WHEREAS, the District anticipates individuals affiliated with Requesting Entity will be required to access personally identifiable information related to students and educational data in order to effectively provide services to the District; and

WHEREAS, both the Family Educational Rights and Privacy Act ("FERPA") and the Minnesota Government Data Practices Act ("MGDPA") allow certain contractors, consultants, volunteers, and other parties to access information that would otherwise be protected from disclosure under a "school official" exception; and

WHEREAS, individuals affiliated with Requesting Entity will be providing services in a manner that meets the relevant requirements to qualify as a "school official" under both FERPA and the MGDPA; and

WHEREAS, the Parties wish to enter into this Agreement in order to outline in greater detail the terms and conditions upon which individuals affiliated with Requesting Entity will be granted access to certain protected student data as a "school official."

NOW, THEREFORE, in consideration of the mutual promises contained in this Agreement, the parties agree to the following:

1. **Services Provided to the District.** Requesting Entity is a NON-PROFIT ORGANIZATION whose TUTOR will provide *EDUCATIONAL SUPPORT* to the District. The services to be provided to the District are institutional services and functions for which the District would otherwise use its own employees.
2. **Protected Student Data Defined.** "Protected Student Data" means any data defined as "personally identifiable information" contained in educational records as the term is defined in FERPA and its implementing regulations, 20 U.S.C. §

1232g and 34 C.F.R. § 99.31, or “educational data” as defined in the MGDPA, Minn. Stat. § 13.32.

3. **Types of Data to be Accessed.** In the course of providing the services described in Paragraph 1, individuals affiliated with Requesting Entity will have a legitimate need to access Protected Student Data in the form of ATTENDANCE, GRADES, GRADEBOOK, TRANSCRIPTS, TEST SCORES AND SCHEDULES. The data described in this Paragraph is subject to disclosure restrictions imposed by FERPA and the MGDPA.

4. **District’s Control over Use and Maintenance of Data.** The following terms and conditions will govern the manner in which individuals affiliated with Requesting Entity will have access to Protected Student Data:
 - a. *TUTOR* shall be the only representatives of Requesting Entity granted access to Protected Student Data in accordance with the terms of this Agreement. Protected Student Data shall not be shared with any employee, agent, volunteer, or other affiliate of Requesting Entity who is not within the group of individuals defined in this Paragraph. Prior to being granted access to Protected Student Data, each TUTOR must review and sign the acknowledgement and consent form attached hereto as Exhibit A.

 - b. Requesting Entity shall not attempt to use, access, or maintain Protected Student Data for any reason other than purposes legitimately necessary for its TUTOR to provide the services referenced in Paragraph 1. Requesting Entity shall not maintain its own files, documents, or any other form of records containing Protected Student Data or attempt to obtain access to Protected Student Data for anyone other than an individual described Paragraph 4(a).

 - c. The use and maintenance of Protected Student Data by TUTOR shall be at all times subject to the District’s direct control.

 - d. Individuals providing services as TUTOR shall be granted access to Protected Student Data through the District’s Infinite Campus system in a manner deemed appropriate by the District. Requesting Entity shall supply the District with a list of the names of the individuals providing services as TUTOR to the principal of the building in which each individual will be providing services. Upon receipt of the list of names, the District will determine using its sole discretion the extent to which each individual will be granted access to Protected Student Data through the Infinite Campus system. Under no circumstance will an individual be granted greater access to Protected Student Data than what is legitimately necessary to effectively provide the services listed in Paragraph 1. The District retains the right to alter at any time and in its sole discretion the manner in which individuals

providing services as TUTOR access Protected Student Data. No individual will be granted access to Protected Student Data unless the person has signed the form attached as Exhibit A and provided a copy to the principal of the building in which the individual will be providing services.

- e. The individuals providing services as TUTOR shall not copy, duplicate, alter, modify, or otherwise make changes to or reproductions of Protected Student Data unless legitimately necessary to perform the services described in Paragraph 1. If any individual who has been granted access to data in accordance with this agreement has maintained copies or other reproductions of Protected Student Data for legitimate purposes, such copies or other reproductions must be destroyed within 30 days of the expiration of this Agreement.
 - f. The District reserves the right to restrict, modify, or discontinue the use and maintenance of Protected Student Data authorized by this agreement for any reason. If the District exercises its sole discretion to restrict or cancel access to data, Requesting Entity and/or its affected representatives shall destroy any copies or reproductions of data which they no longer have access in accordance with the timeframe and requirements of Paragraph 4(f) of this Agreement.
5. **Redisclosure of Protected Student Data.** In the course of performing the services described in Paragraph 1, the Parties agree that individuals providing services to the district as TUTOR shall not redisclose Protected Student Data to any representative of Requesting Entity not within the class of individuals identified in Paragraph 4(a) or any person or party other than a school official with a legitimate need to access the data unless disclosure is specifically authorized or required by law. In the event a parent or eligible student requests disclosure of Protected Student Data to a third party, Requesting Entity and its representatives shall direct the requesting parent or eligible student to the appropriate building principal, who will process each request to disclose Protected Student Data in accordance with applicable District policies and procedures.
6. **Data Related to TUTOR Evaluations.** The Parties agree that data maintained by the District with respect to individuals who perform services on a voluntary basis for the District is defined as personnel data by the MGDPA, Minn. Stat. § 13.43. In the event Requesting Entity requests information from the District that is not classified as public data pursuant to Minn. Stat. § 13.43, subd. 2, Requesting Entity shall obtain a written consent of the subject of the data prior to requesting the data from the District.

7. **Term.** This agreement shall be valid from the date duly approved by both Parties through June 30, 2027. On July 1, 2027, this agreement shall terminate and the District will terminate the ability of the individuals described in Paragraph 4(a) to access Protected Student Data.
8. **Successors and Assigns.** This Agreement will be binding upon and inure to the benefit of the Parties and their respective successors and permitted assigns. No Party may assign or transfer this Agreement or any of its rights, interests or obligations hereunder without the prior written consent of the other Party.
9. **Amendment/Modification.** This Agreement may be amended or modified only by a writing executed by the Parties. No custom or practice of the Parties at variance with the terms hereof will have any effect.
10. **Entire Agreement.** This Agreement constitutes the entire agreement and understanding of the parties relative to the subject matter hereof. The parties have not relied upon any promises, representations, warranties, agreements, covenants or undertakings, other than those expressly set forth or referred to herein. This Agreement replaces and supersedes any and all prior oral or written agreements, representations and discussions relating to such subject matter.

IN WITNESS HEREOF, the Parties have executed this Agreement as of the date first written above.

DATE: _____ By: _____
 Director of Assessment / Evaluation / Performance

DATE: 4-28-26 By: AMY GALAROWICZ

Title: DIRECTOR, TRIO UPWARD BOUND & UPWARD BOUND MATH + SCIENCE
 Phone: 218-723-6760

DATE: 4-28-26 By: Simone Znuich
 Executive Director, Business Services, Duluth Public Schools

**DATA SHARING AGREEMENT FOR RELEASE
OF DATA UNDER “SCHOOL OFFICIAL” EXCEPTION**

This Data Sharing Agreement (“Agreement”) between Independent School District No. 709, Duluth Public Schools (“District”) and THE COLLEGE OF ST. SCHOLASTICA, TRIO TALENT SEARCH is entered into as of July 1, 2026. (Effective Date”). The District and THE COLLEGE OF ST. SCHOLASTICA, TRIO TALENT SEARCH are referred to collectively as the “Parties.”

WHEREAS, certain individuals affiliated with THE COLLEGE OF ST. SCHOLASTICA, TRIO TALENT SEARCH (hereinafter “Requesting Entity”) will provide *EDUCATIONAL SUPPORT* to the District for the 2026-2027 school year; and

WHEREAS, the services to be provided by individuals affiliated with Requesting Entity are institutional services and functions for which the District would otherwise use its own employees; and

WHEREAS, the District anticipates individuals affiliated with Requesting Entity will be required to access personally identifiable information related to students and educational data in order to effectively provide services to the District; and

WHEREAS, both the Family Educational Rights and Privacy Act (“FERPA”) and the Minnesota Government Data Practices Act (“MGDPA”) allow certain contractors, consultants, volunteers, and other parties to access information that would otherwise be protected from disclosure under a “school official” exception; and

WHEREAS, individuals affiliated with Requesting Entity will be providing services in a manner that meets the relevant requirements to qualify as a “school official” under both FERPA and the MGDPA; and

WHEREAS, the Parties wish to enter into this Agreement in order to outline in greater detail the terms and conditions upon which individuals affiliated with Requesting Entity will be granted access to certain protected student data as a “school official.”

NOW, THEREFORE, in consideration of the mutual promises contained in this Agreement, the parties agree to the following:

1. **Services Provided to the District.** Requesting Entity is a *NON - PROFIT ORGANIZATION* whose *TUTOR* will provide *EDUCATIONAL SUPPORT* to the District. The services to be provided to the District are institutional services and functions for which the District would otherwise use its own employees.
2. **Protected Student Data Defined.** “Protected Student Data” means any data defined as “personally identifiable information” contained in educational records

as the term is defined in FERPA and its implementing regulations, 20 U.S.C. § 1232g and 34 C.F.R. § 99.31, or “educational data” as defined in the MGDPA, Minn. Stat. § 13.32.

3. **Types of Data to be Accessed.** In the course of providing the services described in Paragraph 1, individuals affiliated with Requesting Entity will have a legitimate need to access Protected Student Data in the form of ATTENDANCE, GRADES, GRADEBOOK, TRANSCRIPTS, TEST SCORES AND SCHEDULES. The data described in this Paragraph is subject to disclosure restrictions imposed by FERPA and the MGDPA.
4. **District’s Control over Use and Maintenance of Data.** The following terms and conditions will govern the manner in which individuals affiliated with Requesting Entity will have access to Protected Student Data:
 - a. *TUTOR* shall be the only representatives of Requesting Entity granted access to Protected Student Data in accordance with the terms of this Agreement. Protected Student Data shall not be shared with any employee, agent, volunteer, or other affiliate of Requesting Entity who is not within the group of individuals defined in this Paragraph. Prior to being granted access to Protected Student Data, each STUDENT TEACHERS must review and sign the acknowledgement and consent form attached hereto as Exhibit A.
 - b. Requesting Entity shall not attempt to use, access, or maintain Protected Student Data for any reason other than purposes legitimately necessary for its TUTOR to provide the services referenced in Paragraph 1. Requesting Entity shall not maintain its own files, documents, or any other form of records containing Protected Student Data or attempt to obtain access to Protected Student Data for anyone other than an individual described Paragraph 4(a).
 - c. The use and maintenance of Protected Student Data by TUTOR TEACHERS shall be at all times subject to the District’s direct control.
 - d. Individuals providing services as TUTOR shall be granted access to Protected Student Data through the District’s Infinite Campus system in a manner deemed appropriate by the District. Requesting Entity shall supply the District with a list of the names of the individuals providing services as TUTOR to the principal of the building in which each individual will be providing services. Upon receipt of the list of names, the District will determine using its sole discretion the extent to which each individual will be granted access to Protected Student Data through the Infinite Campus system. Under no circumstance will an individual be granted greater access

to Protected Student Data than what is legitimately necessary to effectively provide the services listed in Paragraph 1. The District retains the right to alter at any time and in its sole discretion the manner in which individuals providing services as TUTOR access Protected Student Data. No individual will be granted access to Protected Student Data unless the person has signed the form attached as Exhibit A and provided a copy to the principal of the building in which the individual will be providing services.

- e. The individuals providing services as TUTOR shall not copy, duplicate, alter, modify, or otherwise make changes to or reproductions of Protected Student Data unless legitimately necessary to perform the services described in Paragraph 1. If any individual who has been granted access to data in accordance with this agreement has maintained copies or other reproductions of Protected Student Data for legitimate purposes, such copies or other reproductions must be destroyed within 30 days of the expiration of this Agreement.
 - f. The District reserves the right to restrict, modify, or discontinue the use and maintenance of Protected Student Data authorized by this agreement for any reason. If the District exercises its sole discretion to restrict or cancel access to data, Requesting Entity and/or its affected representatives shall destroy any copies or reproductions of data which they no longer have access in accordance with the timeframe and requirements of Paragraph 4(f) of this Agreement.
5. **Redisclosure of Protected Student Data.** In the course of performing the services described in Paragraph 1, the Parties agree that individuals providing services to the district as STUDENT TEACHERS shall not redisclose Protected Student Data to any representative of Requesting Entity not within the class of individuals identified in Paragraph 4(a) or any person or party other than a school official with a legitimate need to access the data unless disclosure is specifically authorized or required by law. In the event a parent or eligible student requests disclosure of Protected Student Data to a third party, Requesting Entity and its representatives shall direct the requesting parent or eligible student to the appropriate building principal, who will process each request to disclose Protected Student Data in accordance with applicable District policies and procedures.
6. **Data Related to TUTOR Evaluations.** The Parties agree that data maintained by the District with respect to individuals who perform services on a voluntary basis for the District is defined as personnel data by the MGDPA, Minn. Stat. § 13.43. In the event Requesting Entity requests information from the District that is not classified as public data pursuant to Minn. Stat. § 13.43, subd. 2, Requesting

Entity shall obtain a written consent of the subject of the data prior to requesting the data from the District.

7. **Term.** This agreement shall be valid from the date duly approved by both Parties through June 30, 2027. On July 1, 2027, this agreement shall terminate and the District will terminate the ability of the individuals described in Paragraph 4(a) to access Protected Student Data.
8. **Successors and Assigns.** This Agreement will be binding upon and inure to the benefit of the Parties and their respective successors and permitted assigns. No Party may assign or transfer this Agreement or any of its rights, interests or obligations hereunder without the prior written consent of the other Party.
9. **Amendment/Modification.** This Agreement may be amended or modified only by a writing executed by the Parties. No custom or practice of the Parties at variance with the terms hereof will have any effect.
10. **Entire Agreement.** This Agreement constitutes the entire agreement and understanding of the parties relative to the subject matter hereof. The parties have not relied upon any promises, representations, warranties, agreements, covenants or undertakings, other than those expressly set forth or referred to herein. This Agreement replaces and supersedes any and all prior oral or written agreements, representations and discussions relating to such subject matter.

IN WITNESS HEREOF, the Parties have executed this Agreement as of the date first written above.

DATE: _____

By: _____
Director of Assessment / Evaluation / Performance

DATE: 4/28/26

By: Kirsten Walker, Kirsten Walker

Title: Director, TR10 Talent Search

Phone: 218-310-5699

DATE: _____

By: Samira Zunic 5.6.26
Exec. Dir. Finance & Business Services

DCYF USE ONLY	Vendor Name ISD 0709	Supplier ID 0000194009	PO Number 3000002289
EIOR Number 946	Originator Name Linda Vang	Division Early Learning Services	

**FY 2026 ANNUAL PLAN AGREEMENT
T# 26A58/ Contract Number 270355
STATE OF MINNESOTA, DEPARTMENT OF CHILDREN, YOUTH, and FAMILIES**

This Annual Plan Agreement (“AGREEMENT”) is between the State of Minnesota, acting through its Department of Children, Youth, and Families, **Early Learning Services Division** (“STATE”), and **ISD 0709 709 Portia Johnson Drive, Duluth, MN 55811; Jennifer.jaros@isd709.org**, an independent contractor, and not an employee of the State of Minnesota (“VENDOR”).

By signing this AGREEMENT, VENDOR agrees to perform the following work under the terms and conditions listed below:

- 1. Terms of Agreement.** The effective date of this AGREEMENT is **April 1, 2026** or the date the State obtains all required signatures under Minn. Stat. § 16C.05, subd. 2, whichever is later.

The expiration date of this AGREEMENT is **June 30, 2026**, or until all obligations have been satisfactorily fulfilled, whichever occurs first.

- 2. Vendor’s Duties.**

- A.** VENDOR, which is not a STATE employee, agrees to perform the following work and services under the terms and conditions listed below:

- Attend a one-hour project orientation and question-and-answer session live or watch the recording.
- Participate in initial conversations with STATE to “get to know” each other and share information about the community and the VENDOR services.
- Together with other communities, participate in kick-off meeting that will introduce a process that will be used to surface the community’s Early Childhood Care and Education (ECCE) issues and solutions.
- Assemble a group of key representatives of various ECCE programs and settings in the community (school-based, Head Start, family child care, and center-based child care) who will serve as members of the VENDOR’s team.
- Engage in every other month (approximately five total) whole group convenings in which the community will identify key ECCE questions, develop solutions, and implement actions that will strengthen and sustain the mixed delivery ECCE system within the community.
- Coordinate and engage in alternating months from the whole group convening (approximately four total) for individual community meeting with STATE team for

DCYF USE ONLY	Vendor Name ISD 0709	Supplier ID 0000194009	PO Number 3000002289
EIOR Number 946	Originator Name Linda Vang	Division Early Learning Services	

support in implementing actions that will strengthen and sustain the mixed delivery ECCE system within the community.

- Complete documentation that will be used to summarize outcomes and recommendations learned from the projects by **June 30, 2026**. This could be in the format of notes, a report, PowerPoint slides, or another format determined in partnership between the VENDOR and STATE.

3. Scope of Agreement. VENDOR must not perform any work under this AGREEMENT until STATE has signed this document and STATE’s Authorized Representative notifies VENDOR to begin work.

4. Conditions of Payment. All services that VENDOR provides pursuant to this AGREEMENT must be performed to STATE’s satisfaction, as STATE determines in its sole discretion. STATE will not pay VENDOR for any work that STATE considers unsatisfactory, or performed in violation of federal, state or local law, ordinance, rule, regulation, or policy. Under Minnesota Statutes, section 16C.08, subdivision 2(10), STATE will not pay more than 90 percent (90%) of the amount due under this AGREEMENT until STATE’s agency head reviews and approves the final product that VENDOR delivers under this AGREEMENT. Accordingly, the STATE will pay full invoice amounts equal to ninety percent (90%) of the total obligation, and then withholding the remaining ten percent (10%). Once work is complete, VENDOR will invoice for the withheld retainage.

5. Consideration and Terms of Payment. STATE will pay for all services that VENDOR performs under this AGREEMENT as follows:

A. Invoices. The STATE will pay VENDOR promptly after VENDOR’s presentation of invoices for services performed if STATE’s Authorized Representative accepts the invoices and services as satisfactory. Invoices are due no later than July 15, 2026 for services from upon execution of the agreement through June 30, 2026.

B. Compensation. STATE will pay VENDOR for services satisfactorily performed as stated in Clause 2.

C. Reimbursement. STATE will reimburse VENDOR for travel and subsistence expenses actually and necessarily incurred by VENDOR in performance of this AGREEMENT in an amount not to exceed **zero dollars (\$0.00)**. Reimbursement will be in the same manner and in no greater amount than is provided in the current Nonrepresented Employees Compensation Plan promulgated by the Commissioner of Minnesota Management and Budget, which is incorporated by reference.¹ STATE will not reimburse VENDOR for travel and subsistence expense incurred outside the State of Minnesota unless STATE has given VENDOR prior

¹ <https://mn.gov/mmb/employee-relations/labor-relations/labor/nonrepresented-employees-compensation-plan.jsp>

DCYF USE ONLY	Vendor Name ISD 0709	Supplier ID 0000194009	PO Number 3000002289
EIOR Number 946	Originator Name Linda Vang	Division Early Learning Services	

written approval for such out-of-state travel. Minnesota will be considered the home state for determining whether travel is out of state.

- D. Withholding.** STATE will deduct and withhold compensation payable under this AGREEMENT that is subject to withholding under state or federal law.
- E. Total Obligation.** The total obligation of STATE for all compensation and reimbursements to VENDOR shall not exceed **five thousand dollars (\$5,000)**.
- F. Federal funds.** Payments are to be made from federal funds. If at any time such funds become unavailable, this AGREEMENT shall be terminated immediately upon written notice of such fact by STATE to VENDOR. In the event of such termination, VENDOR shall be entitled to payment, determined on a pro rata basis, for services satisfactorily performed. STATE has determined that VENDOR is a “contractor” pursuant to 2 C.F.R section 200.331.
- 6. Termination.** STATE or the Commissioner of the State Department of Administration may terminate this AGREEMENT at any time, with or without cause, after providing 30 days’ written notice of the termination to VENDOR. In the event of such a termination, VENDOR will be entitled to payment, determined on a pro rata basis, for the work or services satisfactorily performed.
- 7. Authorized Representatives and Responsible Authority.**
 - A. State.** STATE’s authorized representative is Linda Vang, Contract Specialist, linda.vang@state.mn.us, or successor, who has the responsibility to monitor VENDOR’s performance and the authority to accept the services provided under this contract. If the services are satisfactory, STATE’s Authorized Representative will certify acceptance on each invoice submitted for payment.
 - B. Vendor.** VENDOR’s Authorized Representative is Jennifer Jaros, ECFE Coordinator, Jennifer.Jaros@isd709.org, or successor. If VENDOR’s Authorized Representative changes at any time during this contract, VENDOR must immediately notify STATE.
- 8. Indemnification.** In the performance of this AGREEMENT by VENDOR and VENDOR’s agents and employees, VENDOR must indemnify, save, and hold harmless STATE, its agents, and employees, from any claims or causes of action, including attorney’s fees incurred by STATE, to the extent caused by VENDOR’s:
 - A.** Intentional, willful, or negligent acts or omissions,
 - B.** Actions that give rise to strict liability, or
 - C.** Breach of contract or breach of warranty.

The indemnification obligations of this section do not apply in the event the claim or cause of action is the result of STATE’s sole negligence. This clause will not be construed to bar any legal remedies VENDOR may have for STATE’s failure to fulfill its obligation under this AGREEMENT.

DCYF USE ONLY	Vendor Name ISD 0709	Supplier ID 0000194009	PO Number 3000002289
EIOR Number 946	Originator Name Linda Vang	Division Early Learning Services	

9. State Audit. Under Minnesota Statutes, 16C.05, subdivision 5, the books, records, documents, and accounting procedures and practices of VENDOR and its employees, agents, subcontractors, or representatives, relevant to this AGREEMENT must be made available and subject to examination by STATE, including the contracting Agency and Division, Legislative Auditor, and State Auditor, for a minimum of six years from the end date of this AGREEMENT.

10. Information Privacy and Security.

- A.** It is expressly agreed that STATE will not be disclosing or providing information protected under the Minnesota Government Data Practices Act, Minnesota Statutes Chapter 13 (the "Data Practices Act"), as "not public data" on individuals to VENDOR under this AGREEMENT. "Not public data" means any data that is classified as confidential, private, nonpublic, or protected nonpublic by statute, federal law, or temporary classification. Minn. Stat. § 13.02, subd. 8a.
- B.** It is expressly agreed that VENDOR will not create, receive, maintain, or transmit "protected health information," as defined in the Health Insurance Portability Accountability Act ("HIPAA"), 45 C.F.R. § 160.103, on behalf of STATE for a function or activity regulated by 45 C.F.R. § 160 or 164. Accordingly, VENDOR is not a "business associate" of STATE, as defined in HIPAA, 45 C.F.R. § 160.103 because of, or in connection with, this AGREEMENT. Therefore, VENDOR is not required to comply with the privacy provisions of HIPAA because of, or for purposes of, performing under this AGREEMENT. If VENDOR has responsibilities to comply with the Data Practices Act or HIPAA for reasons other than this AGREEMENT, VENDOR will be responsible for its own compliance.
- C.** VENDOR must, to the extent VENDOR performs functions of a government entity under Minnesota Statutes, section 13.05, subdivision 11, comply with the Data Practices Act as a governmental entity. Any data created, collected, received, stored, used, maintained or disseminated by VENDOR in performing its duties under this AGREEMENT is subject to the protections of the Data Practices Act, Minnesota Statutes, Chapter 13. The civil remedies of Minnesota Statutes, section 13.08 apply to both VENDOR and STATE's release of the data governed by the Data Practices Act.
- D.** If VENDOR receives a request to release data created, collected, received, stored, used, maintained or disseminated by VENDOR in performing its duties under this AGREEMENT, VENDOR must immediately notify and consult with STATE's Authorized Representative about how VENDOR should respond to the request.
- E.** Under this AGREEMENT, VENDOR will respond appropriately under Minnesota Statutes, sections 13.03 and 13.04 to requests for data created, collected, received, stored, used, maintained, or disseminated by VENDOR in performing its duties under this AGREEMENT.

11. Intellectual Property Rights. Except in the case of intellectual property rights previously acquired by VENDOR, STATE owns all rights, title, and interest in all intellectual property, including copyrights, patents, trade secrets, trademarks, and service marks in the Works created

DCYF USE ONLY	Vendor Name ISD 0709	Supplier ID 0000194009	PO Number 3000002289
EIOR Number 946	Originator Name Linda Vang	Division Early Learning Services	

and paid for under this AGREEMENT. The Works will be the exclusive property of STATE and VENDOR must immediately return all such Works to STATE upon completion or termination of this AGREEMENT. "Works" means all inventions, improvements, discoveries (whether or not patentable or copyrightable), databases, computer programs, reports, notes, studies, photographs, negatives, designs, drawings, specifications, materials, tapes, and disks conceived, reduced to practice, created or originated by VENDOR, its employees, agents, and subcontractors, either individually or jointly with others in the performance of this AGREEMENT. "Works" includes "Documents." "Documents" are the originals of any databases, computer programs, reports, notes, studies, photographs, negatives, designs, drawings, specifications, materials, tapes, disks, or other materials, whether in tangible or electronic forms, that VENDOR, its employees, agents, or subcontractors, prepares in the performance of this AGREEMENT.

12. **Data Disclosure.** Under Minn. Stat. § 270C.65, subd. 3, and other applicable law, VENDOR consents to disclosure of its social security number, federal employer tax identification number, and Minnesota tax identification number, already provided to STATE, to federal and state agencies and state personnel involved in the payment of state obligations. These identification numbers may be used in the enforcement of federal and state laws which could result in action requiring VENDOR to file state tax returns, pay delinquent state tax liabilities, if any, or pay other state liabilities. STATE will not approve this AGREEMENT unless VENDOR provides these numbers.
13. **Governing Law, Jurisdiction, and Venue.** This AGREEMENT is governed by the laws of the State of Minnesota. Venue for all legal proceedings arising out of this AGREEMENT, or breach thereof, will be in the state or federal court with competent jurisdiction in Ramsey County, Minnesota.
14. **Survival of Terms.** The following clauses survive expiration and termination of this AGREEMENT: Indemnification; State Audit; Information Privacy and Security; Intellectual Property Rights; and Governing Law, Jurisdiction, and Venue.
15. **Prohibition on Weapons.** VENDOR agrees that none of its employees or agents will carry or possess a weapon wherever and whenever they perform services within the scope of this AGREEMENT, including in their personal vehicles when they are using the vehicles to perform work under this AGREEMENT. Any violations of this policy by VENDOR or VENDOR's employees may be grounds for immediate suspension or termination of this AGREEMENT.
16. **Assignment.** VENDOR may neither assign nor transfer any rights or obligations under this AGREEMENT without STATE's prior written consent and a fully executed Assignment Agreement, approved by the same parties who executed this AGREEMENT.
17. **Amendments.** Any amendment to this AGREEMENT must be written and will not be effective until it has been executed by the same parties who executed this AGREEMENT.
18. **Waiver.** If STATE fails to enforce any provision of this AGREEMENT, that failure does not waive the provision or STATE's right to enforce it.

DCYF USE ONLY	Vendor Name ISD 0709	Supplier ID 0000194009	PO Number 3000002289
EIOR Number 946	Originator Name Linda Vang	Division Early Learning Services	

- 19. Severability.** If any provision of this AGREEMENT is held to be invalid or unenforceable in any respect, the validity and enforceability of the remaining terms and provisions of this AGREEMENT shall not in any way be affected or impaired. The parties will attempt in good faith to agree upon a valid and enforceable provision that is a reasonable substitute and will incorporate the substitute provision in this AGREEMENT according to clause 17.
- 20. Debarment by State, or its Departments, Commissions, Agencies, or Political Subdivisions.** VENDOR certifies that neither it nor its principles is presently debarred or suspended by the STATE, or any of its departments, commissions, agencies, or political subdivisions. VENDOR’s certification is a material representation upon which this AGREEMENT was based. VENDOR shall provide immediate written notice to STATE’s authorized representative if at any time it learns that this certification was erroneous when submitted or becomes erroneous by reason of changed circumstances.
- 21. Entire Agreement.** This AGREEMENT contains all negotiations and agreements between STATE and VENDOR. No other understanding regarding this AGREEMENT, whether written or oral, may be used to bind either party.

REMAINDER OF PAGE INTENTIONALLY LEFT BLANK.

SIGNATURE PAGE FOLLOWS.

DCYF USE ONLY	Vendor Name ISD 0709	Supplier ID 0000194009	PO Number 3000002289
EIOR Number 946	Originator Name Linda Vang	Division Early Learning Services	

By signing below, the parties agree to the terms and conditions contained in this AGREEMENT.

APPROVED:

1. STATE ENCUMBRANCE VERIFICATION

Individual certifies that funds have been encumbered as required by Minnesota Statutes, chapter 16A and section 16C.05 or Department of Administration Policy 21-01.

By: Laurie D. Hollman
C98E96AB931B467...
 Date: 4/17/2026
 Purchase Order No: 3-2289

2. VENDOR

VENDOR certifies it is not a STATE employee and is an independent contractor. Signatory certifies that VENDOR's articles of incorporation, by-laws, or corporate resolutions authorize Signatory both to sign on behalf of and bind VENDOR to the terms of this AGREEMENT. VENDOR and Signatory agree that STATE relies on the Signatory's certification herein.

By: John Mays
84A532FAE0064E...
 Title: Superintendent
 Date: 4/21/2026

3. STATE AGENCY

With *delegated* authority

By: Meki Kovan
B9C6A2DE65AF4E4...
 Title: Director of Early Learning
 Date: 4/22/2026

Distribution (fully executed contract to each):
 Office of Grants and Contracts
 Vendor
 State Authorized Representative

**Revenue Contracts Signed
April 2026**

For your information, the Superintendent or the Executive Director of Business Services has signed the following revenue contracts during the above timeframe:

Name	Amount or Estimated Amount*	Contract Source	Description
Arrowhead Regional Corrections/Arrowhead Juvenile Center	TBD	TLE	District will provide educational screenings, programs and services to students at ARC/AJC for 2026-2028

AGREEMENT
School Years 2026-27 and 2027-28

THIS AGREEMENT, made and entered into this 24th day of April, 2026, by and between Independent School District #709, a public corporation, (hereinafter called the "District") and Arrowhead Regional Corrections/ Arrowhead Juvenile Center, an independent contractor, (hereinafter called "Contractor".)

THE PURPOSE OF THE AGREEMENT is to set out the terms and conditions whereby District will provide programs or services for the Contractor at the times and locations set forth in this Agreement.

The terms and conditions of this Agreement are as follows:

1. Dates of Service.

This Agreement shall be deemed to be effective as of July 1st, 2026, and shall remain in effect until July 30th 2028, unless terminated earlier as provided for herein, or unless and until all obligations set forth in this Agreement have been satisfactorily fulfilled, whichever occurs first.

2. Performance.

The District will provide the following services:

- a) Educational screenings will be done on all juveniles held longer than 72 hours excluding weekends and Holidays and periods when schools is not in session using the educational screening tool identified by the District, unless the juvenile has a current individual education plan and a copy is in the AJC client's file. (2960 Rule: 125A52 DHS and DOC Education Screening).
- b) Education programs and services will be provided to AJC residents that are consistent with Department of Education rules and statutory requirements governing education of a resident. If it is suspected that a resident has a disability, an educational evaluation must be conducted according to applicable rules to determine if the resident has a disability. Staff will ensure that the appropriate evaluation is completed and will assist a student who has disabilities and needs special education and related services to obtain those services. (2960.0270 Subp. 7.)
- c) Educational services will be provided to residents according to items i-ii, except where not applicable, due to the age of the resident or the resident's short stay in the facility. (2960.0080 Subp. 9.)
 - i) Facilitate educational programs that provide for instruction during the same school calendar established for the other schools in the District, if required by law; get the approval of the education services from the Department of Education
 - ii) Facilitate the resident's school attendance and homework activities.

- d) The District will work with the Contractor to provide transitional programming to ensure a smooth transition back to their home school per the IEP or regular education plan.
- e) The District will work with the Contractor to provide education about chemical health to the resident who has had a problem related to inappropriate chemical use, but who does not have a sufficient chemical use history to refer to treatment. The education must provide the resident with opportunities to examine the problems associated with inappropriate chemical use.

The Contractor will:

- a) Meet the physical plant and equipment requirements of the Department of Education for the provision of educational services.
- b) Cooperate with the District to provide the educational services at AJC and provide correctional services as needed to ensure safety for District staff within the facility.
- c) The Contractor will inquire at least every 90 days to determine whether the resident is receiving the education required by law and the resident's individual education plan that is necessary for the resident to make progress in the appropriate grade level. AJC will report the resident's educational progress to the case manager or placing agency. The contractor will facilitate education for any residents who have already graduated.

3. Background Check.

The Contractor follows the Department of Corrections and Department of Public Health license rules and does criminal record checks on all employees before they can be hired and work directly with any residents. The District is responsible for following license requirements as required by the Minnesota Department of Education and Minnesota statutes. Both the Contractor and District are precluded from performance of contract until the results of the criminal background check(s) are on file.

4. Reimbursement.

The District will provide services to residents of District #709 who are at AJC and bill for residents of Minnesota school districts for reimbursement at the current rate established by ISD #709 in accordance with current state statutes. For out of state school districts, AJC will reimburse the District at the current rate established by ISD #709 in accordance with current state statutes and will bill out of state counties for educational services provided to youth in AJC for more than 72 hours, excluding weekends and holidays. AJC's contracts with out of state counties will specify that the counties will be responsible for educational costs for youth residing at AJC longer than 72 hours.

5. Requests for Reimbursement. The terms of payment under this Agreement are as follows:

- a. There is no exchange of money from the District to AJC. The District bills directly to other districts for payment back to the District.

b. Any other terms of payment in the performance of services are incorporated by reference in this Agreement.

6. Propriety of Expenses.

The fact that the District has reimbursed Contractor for any expense claimed by Contractor shall not preclude District from questioning the propriety of any such item. This clause shall not be construed to bar any other legal remedies District may have to recover funds expended by Contractor for disallowed costs.

7. Ownership of Materials.

The District reserves the rights to reproduce the programming in any fashion, or appropriate the contents of the programming, or any portion thereof, to its own use for any and all programs, forms and other materials that the District has provided, prepared, or utilized in performance of the terms of this Agreement.

8. Independent Contractor.

Both the District and Contractor agree that they will act as an independent contractor in the performance of its duties under this Agreement. Nothing contained in this Agreement shall be construed as in any manner creating a relationship of joint venture between the parties, which shall remain independent contractors with respect to all actions performed pursuant to this Agreement.

Accordingly, Contractor shall be responsible for payment of all taxes, including Federal, State, and local taxes, arising out of Contractor's activities in accordance with this Agreement, including by way of illustration, but not limited to, Federal and State income tax, Social Security tax, Unemployment Insurance taxes, workers compensations, and any other taxes or business license fees as required.

9. Indemnity and defense of the District.

Contractor hereby agrees to defend, indemnify and hold the District harmless from all claims relating to its work pursuant to this Agreement. In the event that Contractor breaches its obligation to defend, indemnify and hold the District harmless, then in addition to its other damages the District shall be entitled to recover its attorney's fees and costs and disbursements incurred in enforcing this Agreement.

The District hereby agrees to defend, indemnify and hold the Contractor harmless from all claims relating to its work pursuant to this Agreement. In the event that the District breaches its obligation to defend, indemnify and hold the District harmless, then in addition to its other damages the Contractor shall be entitled to recover its attorney's fees and costs and disbursements incurred in enforcing this Agreement.

10. Notices.

All notices to the District shall be sent in writing to Director of Business Services, ISD 709, Duluth Public Schools, 709 Portia Johnson Drive, Duluth MN 55811. All notices to Contractor shall be sent in writing to Superintendent, Arrowhead Juvenile Center, 1918 Arlington Avenue North, Duluth, MN 55811.

11. Assignment.

Contractor shall in any way assign or transfer any of its rights, interests or obligations under this Agreement in any way whatsoever without the prior written approval of the District.

12. Modification or Amendment.

No amendment, change or modification of this Agreement shall be valid unless it is in writing and signed by the parties' hereto.

13. Governing Laws.

This Agreement, together with all its paragraphs, terms and provisions is made in the State of Minnesota and shall be construed and interpreted in accordance with the laws of the State of Minnesota.

14. Entire Agreement.

This Agreement contains the entire understanding of the parties hereto with respect to the subject matter hereof and shall not be changed or otherwise altered except by written agreement of the parties.

15. Cancellation.

Either party shall have the right to terminate this Agreement, without cause, upon (30) days written notice to the other party as provided for in this Agreement.

16. Data Practices.

Contractor and District further understand and agree that they shall be bound by the Minnesota Government Data Practices Act (Minnesota Statutes 13.03-13.04) with respect to "data on individuals"; as defined in 13.02, subd. 5 of that Statute) which it collects, receives, stores, uses, creates or disseminates pursuant to this Agreement.

17. Insurance.

Contractor shall not commence work under the contract until they have obtained all the insurance described below and Duluth Public Schools has approved such insurance. Contractor shall maintain such insurance in force and effect throughout the term of the contract.

Contractor is required to maintain and furnish satisfactory evidence of the following insurance policies:

The following insurance must be maintained for the duration of this contract. A Certificate of Insurance for each policy must be on file with AJC within 10 days of execution of this contract and prior to commencement of any work under this contract. Each certificate must include a 10 day notice of cancellation, non-renewal, or material change to all named and additional insureds.

AJC reserves the right to rescind any contract not in compliance with these requirements and retains all rights thereafter to pursue any legal remedies against ISD 709. All insurance policies shall be open to inspection by AJC, and copies of policies shall be submitted to AJC upon written request. All subcontractors shall provide evidence of similar coverage.

A. General Liability Insurance.

1. \$500,000 for claims for wrongful death and each claimant for other claims.
\$1,500,000 Each Occurrence.
No Less Than \$2,000,000 Aggregate coverage.
2. Policy shall include leased remises, operations, completed operations, independent contractors and subcontractors, and contractual liability and environmental liability.
3. AJC must be named as additional insured.

B. Business Automobile Liability Insurance.

1. \$500,000 Each person;
2. \$1,500,000 Each Occurrence.
3. Must cover owned, leased, or rented vehicles

18. Workers Compensation Insurance: per statutory requirements.

Contractor must provide Worker's Compensation insurance for all its employees and, in case any work is subcontracted, Contractor will require the subcontractor to provide Workers' Compensation insurance in accordance with the statutory requirements of the State of Minnesota including Coverage B, Employer's Liability.

REMAINDER OF PAGE LEFT BLANK INTENTIONALLY

AS EVIDENCE OF THEIR ASSENT TO THE TERMS AND CONDITIONS OF THIS AGREEMENT, set forth above, the parties hereto have caused this Agreement to be executed by their duly authorized officers as of the day and year first above written.

INDEPENDENT SCHOOL DISTRICT NO. 709

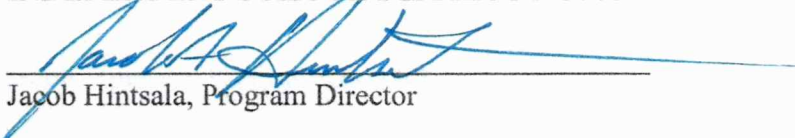

Jacob Hintsala, Program Director

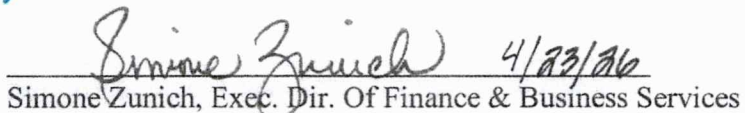

Simone Zurich, Exec. Dir. Of Finance & Business Services

**ARROWHEAD REGIONAL CORRECTIONS (ARC)
ARROWHEAD JUVENILE CENTER (AJC)**

Wendy Skottegard-Burke, AJC Division Director

Becky Pogatchnik, ARC Executive Director

APPROVED AS TO FORM & EXECUTION

Assistant St. Louis County Attorney

Damion Number:

Grant Applications April 2026

For your information, the Assistant Superintendent and/or the CFO, Executive Director of Business Services have approved the following grant applications during the above month:

Organization	Author/Contact	Project Title	Amount Requested	Terms
Llyod K Johnson Foundation	Sarah Laulunen	Check & Connect	\$2,500.00	The funding would go toward basic program needs like student incentives, organizational supplies and other materials we use regularly to keep students engaged and on track. These supports make a noticeable difference in maintaining consistent contact and reinforcing positive progress.
St Louis County Family Service Collab	Todd McGowan	MTSS/SEL	TBD \$10.00 per student with a cap	Purchase SEL curriculum for k-12

**Change Orders Signed
April 2026**

For your information, the Superintendent or the Executive Director of Business Services has signed the following no cost contracts during the above timeframe:

Contractor Name	Contract Source	Description
A.G. O'Brien	Facilities	Finishes and mail room, modifications to the fin tube radiation and steam relief insulation at First Street Buildout (+\$9,865.38)
Belknap Electric	Facilities	Nine electrical changes at First Street Buildout (+\$24,236.19)



CCO #004

ICS
 1331 Tyler Street NE, Suite 101
 Minneapolis, Minnesota 55413
 Phone: (763) 354-2670
 Fax: (763) 780-2866

Project: S23075 - Duluth Public Schools, ISD #709 - DNT Building
 Renovation
 424 West First Street
 Duluth, Minnesota 55802

Contract Change Order #004: A.G. O'Brien CCO #004

CONTRACT COMPANY:	A.G. O'Brien Plumbing and Heating Co. 4907 Lightning Drive Duluth, Minnesota 55811	CONTRACT FOR:	SC-S23075-012:WS 12 - Mechanical
DATE CREATED:	3/27/2026	CREATED BY:	Jason Filipek (ICS - Duluth, MN)
CONTRACT STATUS:	Pending - Proceeding	REVISION:	0
REQUEST RECEIVED FROM:		LOCATION	
DESIGNATED REVIEWER:		REVIEWED BY:	
DUE DATE:		REVIEW DATE:	
INVOICED DATE:		PAID DATE:	
REFERENCE:		CHANGE REASON:	Allowance
PAID IN FULL:	No	EXECUTED:	No
ACCOUNTING METHOD:	Amount Based	SCHEDULE IMPACT:	
FIELD CHANGE:	No	TOTAL AMOUNT:	\$9,865.38

DESCRIPTION:
 CE #044 - PR #7 Finishes and Mail Room: \$2,710.75
 PR #7 Finishes and Mail Room
 CE #046 - PR #8- Modifications to the Fin Tube Radiation: \$6,057.38
 CE #059 - #54: PR 6 Steam Relief Insulation: \$1,097.25

ATTACHMENTS:
[PR_STEAM INSULATION \(1\).pdf](#) [PR08_REV1 \(1\).pdf](#) [PR07 REV 1.pdf](#)

CHANGE ORDER LINE ITEMS:
CCO #004

#	Cost Code	Description	Type	Amount
1	05-5.12 - WS 12 - A.G. O'Brien	PR 7	Other	\$ 2,710.75
2	05-5.12 - WS 12 - A.G. O'Brien	PR 8	Other	\$ 6,057.38
3	05-5.12 - WS 12 - A.G. O'Brien	Steam Relief Insulation	Other	\$ 1,097.25
Subtotal:				\$9,865.38
Grand Total:				\$9,865.38

The original (Contract Sum)	\$ 3,772,468.00
Net change by previously authorized Change Orders	\$ 44,355.32
The contract sum prior to this Change Order was	\$ 3,816,823.32
The contract sum would be changed by this Change Order in the amount of	\$ 9,865.38
The new contract sum including this Change Order will be	\$ 3,826,688.70
The contract time will not be changed by this Change Order by	



CCO #004

A.G. O'Brien Plumbing and Heating Co.
4907 Lightning Drive
Duluth Minnesota 55811

Signed by:

Brady Berkhof

SIGNATURE DATE

3/31/2026

ICS

ICS - Duluth, MN
525 Lake Ave S, Suite 222
Duluth Minnesota 55802

Signed by:

Jason Filipek

SIGNATURE DATE

3/30/2026

page 2 of 2

DS
BB

Duluth Public Schools ISD #709
709 Portia Johnson Drive
Duluth Minnesota 55811

Signed by:

Simone Bunick

SIGNATURE DATE

4/7/2026

Printed On: 3/30/2026 07:25 AM



CHANGE ORDER TRACKING

PROJECT: ISD 709 DNT Renovation; Insulation Steam Relief Add

DATE 12/8/2025

FLOOR _____

LABOR				
CRAFT	HOURS	NAME	RATE	TOTAL
				\$ -
				\$ -
				\$ -
				\$ -
				\$ -
Labor Total				\$ -

MATERIALS			
QUANTITY	PRODUCT	COST	TOTAL
			\$ -
			\$ -
			\$ -
			\$ -
			\$ -
			\$ -
			\$ -
Materials Total			\$ -

Total		\$ -
Sales tax (Materials Only)	8.875%	\$ -
Subtotal		\$ -
Markup (Overhead & Profit) on subtotal	10%	\$ -
Total contractor costs with markup		\$ -
Subcontractor costs	LSI STEAM INSULATION	\$ 1,045.00
Subcontractor markup	5.0%	\$ 52.25
Total Subcontractor cost with markup		\$ 1,097.25
Bond/Permit	0%	
Total Change Order		\$ 1,097.25

TASK DESCRIPTION

A.G. O'BRIEN REPRESENTATIVE: _____ Signature _____ Date 12/8/2025
 _____ Printed Name | Title
 Brady Berkhof

CUSTOMER REPRESENTATIVE: _____ Signature _____ Date _____
 _____ Printed Name | Title



CHANGE ORDER TRACKING

DATE 2/19/2026

PROJECT: ISD 709 DNT Renovation; PR-08 Changes

FLOOR _____

LABOR				
CRAFT	HOURS	NAME	RATE	TOTAL
PL	32.00	ADDITIONAL PIPE, FITTINGS HANGER INSTALL	\$ 110.23	\$ 3,527.36
PL	6.00	CORNER BRACKETS	\$ 110.23	\$ 661.38
PL	10.00	34' FTR INSTALL DEDUCT	\$ (110.23)	\$ (1,102.30)
			\$ -	\$ -
			\$ -	\$ -
		Labor Total		\$ 3,086.44

MATERIALS			
QUANTITY	PRODUCT	COST	TOTAL
1.00	COPPER PIPE, 90S, TEES	\$ 1,110.90	\$ 1,110.90
1.00	FTR BRACKET, CORNER, & COVER ADDS	\$ 1,640.00	\$ 1,640.00
1.00	34' FTR DEDUCT	\$ (1,580.00)	\$ (1,580.00)
		\$ -	\$ -
	Materials Total		\$ 1,170.90

	Total		\$ 4,257.34
Sales tax (Materials Only)	8.875%		\$ 103.92
Subtotal			\$ 4,361.26
Markup (Overhead & Profit) on subtotal	10.0%		\$ 436.13
Total contractor costs with markup			\$ 4,797.38
Subcontractor costs	Additional insulation		\$ 1,200.00
Subcontractor markup	5.0%		\$ 60.00
Total Subcontractor cost with markup			\$ 1,260.00
Bond/Permit	0%		
	Total Change Order		\$ 6,057.38

TASK DESCRIPTION

A.G. O'BRIEN REPRESENTATIVE:

 Signature 2/5/2026
 Date
 Paul Konkler
 Printed Name | Title

CUSTOMER REPRESENTATIVE:

 Signature Date
 Date
 Printed Name | Title



CHANGE ORDER TRACKING

DATE 2/5/2026

PROJECT: ISD 709 DNT Renovation; PR-07 Changes

FLOOR _____

LABOR				
CRAFT	HOURS	NAME	RATE	TOTAL
SM	8.00	Duct install changes	\$ 110.23	\$ 881.84
SM	4.00	Duct fabrication changes	\$ 110.23	\$ 440.92
Plumb	0.00	Refrigeration route changes	\$ 110.23	\$ -
SM	1.50	Added GRD install	\$ 110.23	\$ 165.35
				\$ -
Labor Total				\$ 1,488.11

MATERIALS			
QUANTITY	PRODUCT	COST	TOTAL
3.00	Added GRDs	\$ 68.75	\$ 206.25
0.00	Extra refrigeration pipe and fittings	\$ 428.65	\$ -
1.00	Extra duct fabrication material	\$ 252.02	\$ 252.02
			\$ -
Materials Total			\$ 458.27

Total		\$ 1,946.38
Sales tax (Materials Only)	8.875%	\$ 40.67
Subtotal		\$ 1,987.05
Markup (Overhead & Profit) on subtotal	10.00%	\$ 198.70
Total contractor costs with markup		\$ 2,185.75
Subcontractor costs	Insulation	\$ 500.00
Subcontractor markup	5.00%	\$ 25.00
Total Subcontractor cost with markup		\$ 525.00
Bond/Permit	0%	
Total Change Order		\$ 2,710.75

TASK DESCRIPTION
Changes to duct runs, extra GRDs, and moving one of the minisplit units in the basement.

A.G. O'BRIEN REPRESENTATIVE:

 Signature Date 2/5/2026
 Brady Berkhof
 Printed Name | Title

CUSTOMER REPRESENTATIVE:

 Signature Date
 Printed Name | Title



CCO #005

ICS
 1331 Tyler Street NE, Suite 101
 Minneapolis, Minnesota 55413
 Phone: (763) 354-2670
 Fax: (763) 780-2866

Project: S23075 - Duluth Public Schools, ISD #709 - DNT Building
 Renovation
 424 West First Street
 Duluth, Minnesota 55802

Contract Change Order #005: Belknap Electric CCO #005

CONTRACT COMPANY:	Belknap Electric 1513 Belknap St Superior, Wisconsin 54880	CONTRACT FOR:	SC-S23075-013:WS 13 - Electrical
DATE CREATED:	3/27/2026	CREATED BY:	Jason Filipek (ICS - Duluth, MN)
CONTRACT STATUS:	Pending - Proceeding	REVISION:	0
REQUEST RECEIVED FROM:		LOCATION	
DESIGNATED REVIEWER:		REVIEWED BY:	
DUE DATE:		REVIEW DATE:	
INVOICED DATE:		PAID DATE:	
REFERENCE:		CHANGE REASON:	Allowance
PAID IN FULL:	No	EXECUTED:	No
ACCOUNTING METHOD:	Amount Based	SCHEDULE IMPACT:	
FIELD CHANGE:	No	TOTAL AMOUNT:	\$24,236.19
DESCRIPTION: CE #066 - PR 9 electrical changes: \$24,236.19			

ATTACHMENTS:
[2026-0223 - ISD 709-DNT Building Renovation PR No. 9 Belknap Electric.pdf](#)

CHANGE ORDER LINE ITEMS:
CCO #005

#	Cost Code	Description	Type	Amount
1	05-5.13 - WS 13 - Belknap Electric	PR 9 Electrical Changes	Other	\$ 24,236.19
Subtotal:				\$24,236.19
Grand Total:				\$24,236.19

The original (Contract Sum)	\$ 2,668,386.00
Net change by previously authorized Change Orders	\$ 201,177.59
The contract sum prior to this Change Order was	\$ 2,869,563.59
The contract sum would be changed by this Change Order in the amount of	\$ 24,236.19
The new contract sum including this Change Order will be	\$ 2,893,799.78
The contract time will not be changed by this Change Order by	

DS
 BB

Belknap Electric
 1513 Belknap St
 Superior Wisconsin 54880

ICS - Duluth, MN
 525 Lake Ave S, Suite 222
 Duluth Minnesota 55802

Duluth Public Schools ISD #709
 709 Portia Johnson Drive
 Duluth Minnesota 55811

Signed by:

 SIGNATURE DATE
 3/27/2026

Signed by:

 SIGNATURE DATE
 3/27/2026

Signed by:

 SIGNATURE DATE
 4/7/2026 238



1513 Belknop Street | Superior | WI | 54880
 715.394.7769 | www.belknapelectric.com

SUBCONTRACTOR CHANGE REQUEST
CHANGE REQUEST # 9

DATE: Thursday, March 19, 2026
PROJECT: ISD 709 - DNT Building Renovations
PROJECT NO: 33231

TO: Jason Filipek - jason.filipek@ics-builds.com

FROM: Chris Krook - chriskrook@belknapelectric.com

CC: Jacob Majerle - jacob.majerle@ics-builds.com

Description of Work
 Additional wall packs, flag pole lights and circuits. Additional security and door release.

Proposal Breakdown

Labor Hours:	105.15	
Labor Rate:	\$	54.65
Burden on Labor:	\$	53.45
Labor OH&P/Hour:	\$	10.81
(Profit = 10% of actual cost plus overhead)		
Total Labor Rate Per Hour:	\$	118.91
Total Cost of Labor:		\$ 12,503.39

Materials

Materials Cost:	\$	7,373.00
Materials OH&P:	\$	737.30
(Profit = 10% of actual cost plus overhead)		
Total Cost of Materials:		\$ 8,110.30

Subcontractor

Subcontractor Cost:	\$	3,450.00
Subcontractor Profit = 5%	\$	172.50
Total Cost for Subcontractor:		\$ 3,622.50
Total Change Request:		\$ 24,236.19



Job Name: ISD 709
Job Number: ISD 709 - DNT Building Renovation - PR#09
Job Path: P:\BidWinner\2025
Job Category: PR #09
Bid Due Date: 3/19/2026 6:06 AM
Estimator: Chris Krook
Telephone: 715-394-7769
Cell: 218-591-3267
Fax: 715-394-7887
Email: chriskrook@belknapelectric.com

Starting date:
Completion date:
Duration: Weeks

Job address:

Client address:

	Description	Quantity	Total Material	Total Hours
1	3/4" EMT CONDUIT	614	493.59	30.70
2	1" EMT CONDUIT	60	83.75	4.20
3	3/4" EMT DC SS CONN	4	2.80	0.40
4	3/4" EMT DC SS CPLG	4	2.91	0.20
5	3/4" EMT STL SS CONN	36	10.58	3.60
6	1" EMT STL SS CONN	12	6.36	1.44
7	3/4" EMT STL SS CPLG	58	16.23	2.90
8	1" EMT 90 DEG ELBOW	6	20.10	1.32
9	3/4" EMT 1-H STEEL STRAP	10	1.35	0.54

	Description	Quantity	Total Material	Total Hours
10	1" EMT 1-H STEEL STRAP	18	3.15	1.06
11	#12 THHN BLACK	328	66.38	1.69
12	#10 THHN BLACK	1,848	572.01	12.01
13	B2-1 RED WIRE CONN	32	6.74	1.92
14	4x1 1/2" SQ BOX COMB KO	12	14.64	2.76
15	4x2 1/8" SQ BOX COMB KO	14	18.05	3.22
16	4" SQ BLANK COVER	10	4.50	0.25
17	4" SQ 1G PLSTR RING 5/8" RISE	8	6.09	0.20
18	1G DUPLEX REC PLATE - 302 S/S	2	2.50	0.05
19	20A 125V DUPLEX REC - IVY (SG)	2	5.84	0.40
20	#8x 1/2 WAFER HEAD SELF-TAP STUD SCREW - 12G	20	0.79	0.48
21	#12 CEILING WIRE	386	96.50	7.72
22	K-12 KON CLIP (3/4")	55	29.38	2.81
23	EC311 WIRE/ROD SECURE CLIP	65	116.91	3.25
24	812MB18 BOX/CONDUIT 1/4" ROD SUPPORT	10	51.32	0.82
25	4H24 HAMMER-ON 1/4" FLANGE CLIP	65	50.93	3.90
26	20A 1P BRKR BOLT-ON GFI 5mA	2	79.44	0.50
27	ARLINGTON #GP26B LIGHT POSE BASE	2	92.00	1.00
28	MISC WORK ON EXISTING 100A PANEL	1	100.00	4.00
29	TYPE X	6	0.00	5.10
30	FLAG POLE LIGHT - RAB EZLED ESXF LED SERIES	2	0.00	1.70
	Totals	3,692	1,954.85	100.14

	Labor Type	Crew	Hours	Rate \$	Total
2	Foreman	1.00	100.14	108.10	10,825.13
	Totals	1.00	100.14	108.10	10,825.13

	Indirect Labor	Lab %	Hours	Rate \$	SubTotal	Total	Full Rate
1	Additional Management Time	5.000	5.01	#####	541.58	541.58	108.10
	Totals		5.01	#####	541.58	541.58	108.10

	Subcontractors	Alarm	Cost	Tax(%)	Overhead %	Markup %	Total	Vendor
1	Division 27 - Communications	Off	3,450.00			5.000	3,622.50	Dell-Co
	Totals		3,450.00			172.50	3,622.50	

	Subcontractors	Notes
1	Division 27 - Communications	
	Totals	

	General Expenses	Quantity	Duration	Cost/Unit	Total
1	Inspection Permit	1.00		605.00	605.00
2	Travel Expenses - Parking Pass	8.00	13.00	10.35	1,076.40
	Totals				1,681.40

	Quoted Materials	Cost	Vendor	Notes
1	Fixtures & Lamps	3,080.00	Border States	
2	Distribution	192.00	Viking Electric	
	Totals	3,272.00		

Key Indicators	Value	%
Database Material	1,954.85	8.066
Quoted Material	3,272.00	13.500
Material Tax	463.88	1.914
Material Total	5,690.73	23.480
Direct Labor	10,825.13	44.665
Indirect Labor	541.58	2.235
Labor Total	11,366.71	46.900
Subcontractors	3,450.00	14.235
General Expenses	1,681.40	6.938
Prime Cost	22,188.84	91.553
Net Cost	22,188.84	91.553
Total Profit	2,047.35	8.447
Selling Price	24,236.19	100.000
Final Price	24,236.19	100.000
Labor Risk Ratio %	18.0118	
Total Labor Hours	105.15	
Average Labor Cost Per Hour	108.10	
General Expenses Per Hour	15.9905	



Dell-Comm, Inc.
4179 Thunderchief Lane
Duluth, MN 55811-1425
Telephone (218) 623-2666
Fax (218) 623-2667

Change Order Proposal

Project: ISD 709 DNT Building Reno Customer: Belknap Electric
Job Number: 250227 Customer Project No. 25-0012-900
This Change Proposal Covers The Following: Date of Change: 3/9/2026

- PR #9
Item No 05: E600 – BASEMENT LEVEL TECHNOLOGY PLAN
a) Added security to parking ramp exterior door.
Item No 06: E601 – FIRST LEVEL TECHNOLOGY PLAN
a) Revise door release.
Item No 07: E602 – SECOND LEVEL TECHNOLOGY PLAN
a) a) Revise door release

We Propose hereby to furnish material and labor – complete in accordance with above specifications, for the sum of: Three Thousand four hundred and fifty dollars Dollars, \$ \$3,450.00

Terms: Net 15 days, 1.5% per month, 18% annual will be charged on balance 30 days past due.
All material is guaranteed to be as specified. All work to be completed in a workman like manner according to standard practices. Any alteration or deviation from above specifications involving extra costs will be executed only upon written orders, and will become an extra charge over and above the estimate. All agreements contingent upon strikes, accidents or delays beyond our control. Owner to carry fire, tornado and other necessary insurance. Our workers are fully covered by Workman's Compensation Insurance. NOTE: Will not work or be responsible for any cost involving asbestos.

Acceptance of Proposal – The above prices, specifications and conditions are satisfactory and are hereby accepted. You are authorized to do the work as specified. Payment will be made as outlined above.

Dell-Comm, Inc.

By: _____ By: _____
Title: _____ Title: _____
Date: _____ Date: _____

(After acceptance of proposal, complete contact status below)

Change Order #: _____

Original Contract Amount: \$ _____
Previous Approved Change Order #'s: \$ _____
Amount of This Change Order: \$ _____
Revised Contract Amount: \$ _____



Job Name : Duluth Public Schools - ISD709 DNT Building Renovation

Quote Number : 520423-840918-1

Bid Date : Mar 19, 2026

Expiration Date : Mar 29, 2026



PREPARED BY

Jake Thibedeau - Area 14 - Albertville
JThibedeau@borderstates.com
11927 53rd St NE
Albertville, MN 55301, USA

All prices are subject to Manufacturer ' s tariff increases. Tariff adders will be passed on to Buyer.

PRICING AND LEAD TIME ARE SUBJECT TO CHANGE AT ANY TIME WITHOUT NOTICE.

PLEASE ADVISE OF ANY COUNT CHANGES FOR AN UPDATED BILL OF MATERIAL AND QUOTE

New Section				
Qty	Type	Mfg	Model Number & Notes	Lead Time
6	X	BEACON PRODUCTS	RWL2-160-45-4K7-3-U-DBT	-
2	NOTE 2	EXO	SGF2-120-LSCS-UNVC-PC	-
New Section Subtotal				\$3,080.00

Grand Total	\$3,080.00
--------------------	-------------------



Job Name : Duluth Public Schools - ISD709 DNT Building Renovation

Quote Number : 520423-840918-1

Bid Date : Mar 19, 2026

Expiration Date : Mar 29, 2026

General Terms & Conditions

This quotation and all orders tendered pursuant hereto shall be subject to Border States' terms of sale that can be found at <https://solutions.borderstates.com/terms-of-sale/>.

All clerical errors contained herein are subject to correction. In the event of any cost or price increases from manufacturers or other suppliers, caused by, but not limited to, currency fluctuations, raw material or labor prices, fuel or transportation cost increases, and any import tariffs, taxes, fees, or surcharges, Border States reserves the exclusive right to change its pricing at the time of shipping and will provide notice of any such change to its customers prior to costs being incurred.



DATE: _____ LOCATION: _____
 TYPE: _____ PROJECT: _____
 CATALOG #: _____

SLING FLOOD

SGF1/SGF2/SGF3 - SWITCHABLE FLOOD

tradeSELECT®

FEATURES

- Commercial grade LED flood luminaire for use in outdoor application; commercial buildings, retail, government and educational facilities.
- Low profile housing with knuckle installed and trunnion also included for optional field installment (SGF2 and SGF3 only)
- Available in twelve wattages ranging from 20W to 320W
- Three housing sizes for scalability in the field
- 7x7 wide flood distribution



SPECIFICATIONS

CONSTRUCTION

- Die-cast aluminum die-cast housing
- Built in visor on all fixture sizes
- Tempered glass lens secured with sealant. Individual components are not field replaceable
- All units have dark bronze matte textured powder coat finish (matches Current DBT finish)
- Operating Temp -40C to 40C
- Powder paint finish provides durability in outdoor environments. Tested to meet 1000 hour salt spray rating.

OPTICS

- Matte white reflector produces wide 7x7 distribution
- Beam Angle: 115°x108°
- Field Angle: 155°x156°
- Lumen Switchable (3K, 4K, 5K) at 70 CRI

INSTALLATION

- SGF1 includes knuckle mounting only
- SGF2 and SGF3 have a slipfitter installed that fits over 2 3/8" tenon. A trunnion mount is included in the box and can be field installed.

ELECTRICAL

- All configurations are 120-347V
- SJTW Cord rated for 105C and 600V. Cord is 36 inches long with 18AWG conductors.

CONTROLS

- Built in 6kV surge protector
- Optional integral button photocontrol with cover for dusk-to-dawn operation

CERTIFICATIONS

- Listed to UL1598 and CSA C22.2#250.0-24 for wet locations and 40°C ambient temperatures
- Wet listed
- DLC® (DesignLights Consortium Qualified), with some Premium Qualified configurations. Not all product variations listed in this document are DLC® qualified. Refer to <http://www.designlights.org> for the most up-to-date list
- IP66 rated housing

WARRANTY

- 5 year warranty

KEY DATA	
Lumen Range	3,049-46,759
Wattage Range	20-320W
Efficacy Range (LPW)	125-163
Weights lbs. (kg)	2.6-18.4 (1.2-8.3)

Stock SKU	Fixture Size	Wattage	Lumen Output	Color Temp	CRI	Voltage	Controls	Mounting
SGF1-60-LSCS-UNVC-PC	SGF1 Small	20W, 40W, 60W	3049-8214	3K, 4K, 5K	70 CRI	120-347V	Photocell	Knuckle
SGF2-120-LSCS-UNVC-PC	SGF2 Medium	80W, 100W, 120W	10813 - 16488	3K, 4K, 5K	70 CRI	120-347V	Photocell	Knuckle & Trunnion
SGF3-200-LSCS-UNVC	SGF3 Large	130W, 160W, 200W	17811 - 30953	3K, 4K, 5K	70 CRI	120-347V	None	Knuckle & Trunnion
SGF3-200-LSCS-UNVC-PC							Photocell	
SGF3-320-LSCS-UNVC		200W, 280W, 300W	25156 - 46759	3K, 4K, 5K	70 CRI	120-347V	None	Knuckle & Trunnion
SGF3-320-LSCS-UNVC-PC							Photocell	



ORDERING GUIDE
STOCK ORDERING INFORMATION

Fixture Size	Color Temp	Wattage	Lumen Output	Lumens Per Watt	Mounting
SGF1-60	3000	20	3049	152	Knuckle
	4000		3485	174	
	5000		3257	163	
	3000	40	5411	138	
	4000		6184	157	
	5000		5779	147	
	3000	60	7187	123	
	4000		8214	141	
	5000		7676	132	
SGF2-120	3000	80	10813	135	Knuckle & Trunnion
	4000		11677	146	
	5000		11513	144	
	3000	100	13516	132	
	4000		14596	143	
	5000		14391	141	
	3000	120	15268	125	
	4000		16488	135	
	5000		16256	133	
SGF3-200	3000	130	17811	137	Knuckle & Trunnion
	4000		19404	149	
	5000		16541	127	
	3000	160	20801	130	
	4000		23897	149	
	5000		22401	140	
	3000	200	25808	129	
	4000		30953	155	
	5000		27702	139	
SGF3-320	3000	200	25156	126	Knuckle & Trunnion
	4000		29225	146	
	5000		27201	136	
	3000	280	35219	126	
	4000		39824	142	
	5000		37103	133	
	3000	320	40250	127	
	4000		46759	135	
	5000		43521	135	



SLING FLOOD

SGF1/SGF2/SGF3 - SWITCHABLE FLOOD

DATE: _____ LOCATION: _____

TYPE: _____ PROJECT: _____

CATALOG #: _____

ELECTRICAL DATA

Fixture	Input Voltage (Volts)	Oper. Current (Amps)	System Power (Watts)	Fixture	Input Voltage (Volts)	Oper. Current (Amps)	System Power (Watts)
SGF1-20	120	0.17	20	SGF3-130	120	1.08	130
	277	0.07			277	0.47	
	347	0.06			347	0.37	
SGF1-40	120	0.33	40	SGF3-160	120	1.33	160
	277	0.14			277	0.58	
	347	0.12			347	0.46	
SGF1-60	120	0.50	60	SGF2-200	120	1.67	200
	277	0.22			277	0.72	
	347	0.17			347	0.58	
SGF2-80	120	0.67	80	SGF3-200	120	1.67	200
	277	0.29			277	0.72	
	347	0.23			347	0.58	
SGF2-100	120	0.83	100	SGF3-280	120	2.33	280
	277	0.36			277	1.01	
	347	0.29			347	0.81	
SGF2-120	120	1.00	120	SGF3-320	120	2.67	320
	277	0.43			277	1.16	
	347	0.35			347	0.92	

LUMINAIRE AMBIENT TEMPERATURE FACTOR (LATF)

Ambient Temperature		Lumen Multiplier
0°C	32°F	1.03
10°C	50°F	1.01
20°C	68°F	1.00
25°C	77°F	1.00
30°C	86°F	0.99
40°C	104°F	0.98

EPA

EPA (Front/Side)	
SGF1	0.46ft ² /0.16ft ²
SGF2	1.25ft ² /0.45ft ²
SGF3	2.45ft ² /0.60ft ²

PROJECTED LUMEN MAINTENANCE

Calculation Method	Ambient Temp	25,000 hrs	50,000 hrs	60,000 hrs *	100,000 hrs **	Calculated L70 ** (hrs)
TM-21-11	25C/77F	0.94	0.88	0.87	0.78	>54,000
	40C/104F	0.93	0.87	0.86	0.76	>54,000
TM-21-21	25C/77F	0.95	0.88	0.87	n/a	n/a
	40C/104F	0.94	0.87	0.86	n/a	n/a

* Lumen maintenance values calculated per TM-21 using six times the LM-80 test time for the LED and in-situ thermal testing of the luminaire.

** Lumen maintenance values calculated per TM-21-11.

SLING FLOOD

SGF1/SGF2/SGF3 - SWITCHABLE FLOOD

DATE: _____ LOCATION: _____

TYPE: _____ PROJECT: _____

CATALOG #: _____

DIMENSIONS

SGF1

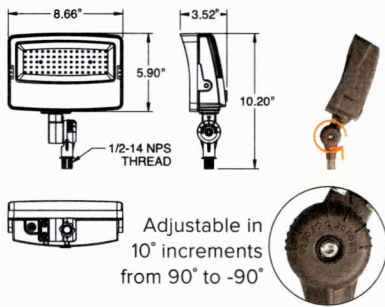

SGF2 (TRUNNION)

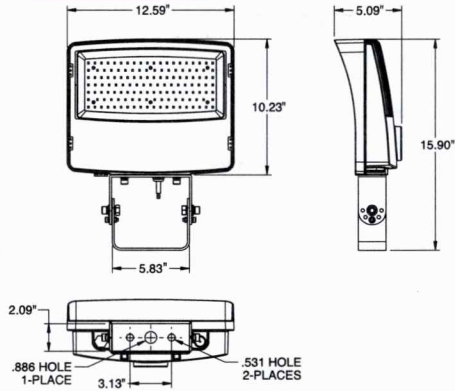

SGF2 (KNUCKLE)

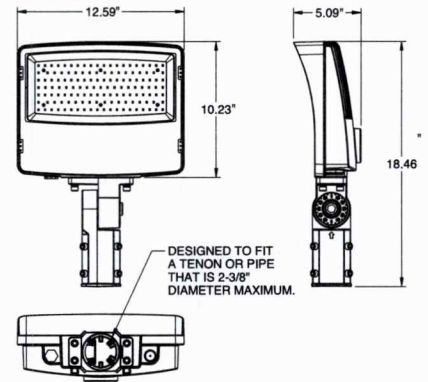

SGF3 (TRUNNION)

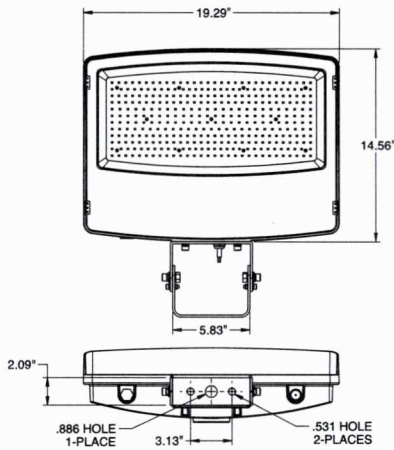

SGF3 (KNUCKLE)

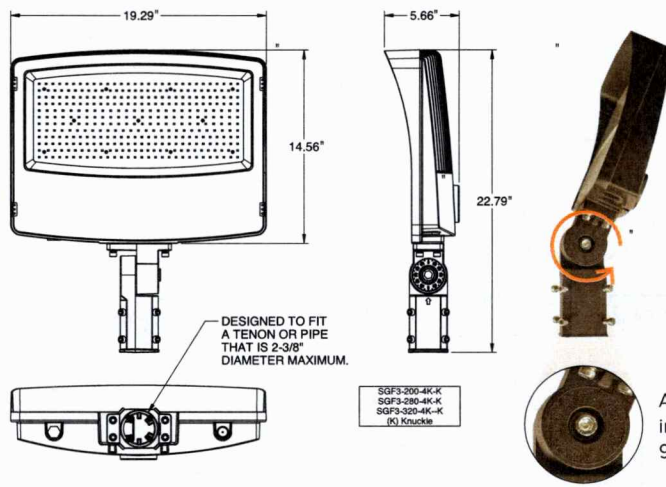

WEIGHT AND DIMENSION CHART

Configuration	Carton Size			Product Weight (lbs)
	L	W	H	Fixture Only
SGF1	12.20"	10.83"	5.71"	3.9 lbs.
SGF2	21.06"	14.76"	7.09"	13.6 lbs.
SGF3	25.00"	21.45"	7.68"	23.8 lbs.

PHOTOCONTROL

Optional integral button photocontrol with cover for dusk-to-dawn operation





SLING FLOOD

SGF1/SGF2/SGF3 - SWITCHABLE FLOOD

DATE: _____ LOCATION: _____

TYPE: _____ PROJECT: _____

CATALOG #: _____

PHOTOMETRY

SGF1

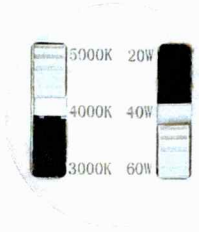

SGF2

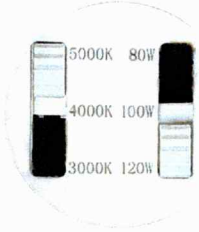

SGF3-200

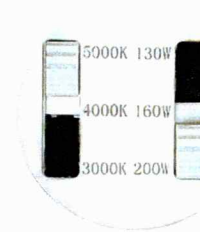

SGF3-320

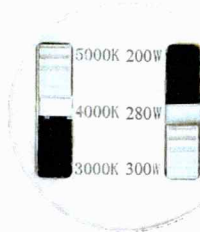

SGF1-20-4K

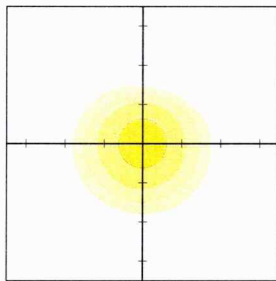

Scale: 20'
Mounting Height: 15'

SGF2-80-4K

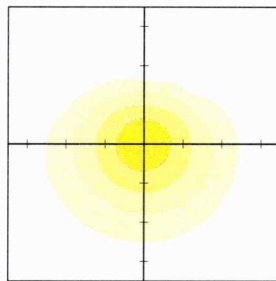

Scale: 20'
Mounting Height: 15'

SGF3-200-130-4K

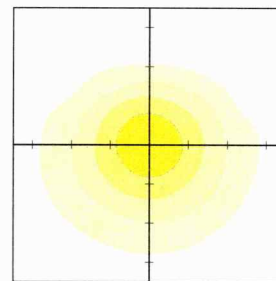

Scale: 20'
Mounting Height: 15'

SGF3-320-200-4K

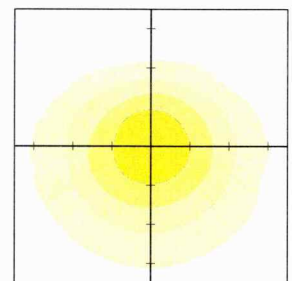

Scale: 20'
Mounting Height: 15'

SGF1-40-4K

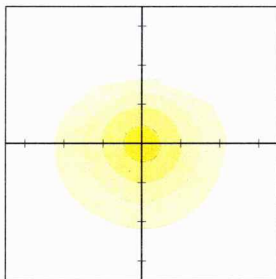

Scale: 20'
Mounting Height: 15'

SGF2-100-4K

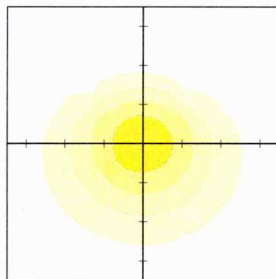

Scale: 20'
Mounting Height: 15'

SGF3-200-160-4K

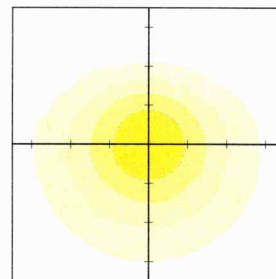

Scale: 20'
Mounting Height: 15'

SGF3-320-280-4K

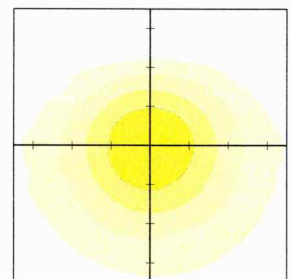

Scale: 20'
Mounting Height: 15'

SGF1-60-4K

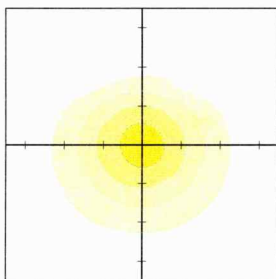

Scale: 20'
Mounting Height: 15'

SGF2-120-4K

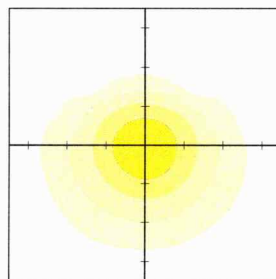

Scale: 20'
Mounting Height: 15'

SGF3-200-200-4K

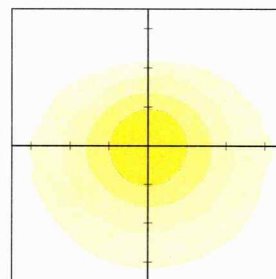

Scale: 20'
Mounting Height: 15'

SGF3-320-320-4K

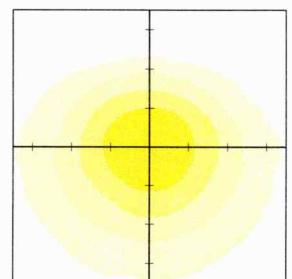

Scale: 20'
Mounting Height: 15'

USE OF TRADEMARKS AND TRADE NAMES

All product and company names, logos and product identifies are trademarks ™ or registered trademarks ® of Current Lighting, Inc. or their respective owners. Use of them does not necessarily imply any affiliation with or endorsement by such respective owners.